

## **CHAPTER 7. THE ELLENGOWAN AND SHEN PENN DEMONSTRATION PROJECTS**

**Barry E. Scheetz, Caroline M. Loop, William B. White**

### **7.1 OBJECTIVES**

The Ellengowan demonstration was initiated to provide an independent review of the potential environmental consequences of placing fluidized bed combustor ash directly into standing waters contaminated with acid mine drainage. Dry-to-wet and wet-to-wet placement techniques were evaluated. The scope of the study included field examination of the emplaced ash, the emplacement method, SPLP evaluation of the leachability of potentially hazardous elements from the ash. The Ellengowan demonstration project was a necessary precursor to the other demonstrations to develop tangible data on a small-scale before embarking on the full-scale demonstrations. The objective of the Shen Penn demonstration was to show that ash could be transported in the form of a slurry and placed in the deep standing waters of the Shen Penn mine pit. This demonstration permit site was never acted upon.

### **7.2 BACKGROUND FOR THE WESTERN MIDDLE FIELD**

#### **7.2.1 Local Geology**

The following description of the geology of the Western Middle anthracite coal field is taken entirely from Danilchik, et al., 1955 "Geology of Anthracite in the Western Part of the Shenandoah Quadrangle, Pennsylvania." The eastern section of the Western Middle Anthracite Field is discussed in the aforementioned report, covers the section C-19 in figure 7.1, and contains the Ellengowan, Knickerbocker, and Shen Penn sites.

The Western Middle Anthracite Field is one of four coal fields containing anthracite in eastern Pennsylvania. The boundary of the Western Middle field is considered to be the outcrop of the oldest of the Lykens Valley Coal beds (Rothrock et al., 1951). Rocks of the Mississippian, Pennsylvanian, and Quaternary systems crop out in the field. The oldest exposed rocks belong to the upper part of the Mauch Chunk Formation of Mississippian age, which is overlain by the Pottsville and Llewellyn Formations of Pennsylvanian age (Fig. 7.2). Unconsolidated alluvial clay, silt, sand, and gravel of Quaternary age have been deposited on the Carboniferous rocks in the stream valleys but were not mapped. Stream transported mine waste, some of which contains valuable deposits of detrital coal, has also been deposited along many streams.

##### **7.2.1.1 Stratigraphy**

The Mauch Chunk Formation crops out in the northern part of the area north of Locust Mountain Basin and in a small area immediately north of Reservoir No. 3. In the southern part of the area, the formation crops out on the crest of the Eisenhuth Run anticline, in the valley occupied by Mill Creek, and in the Locust Creek Valley. Only the upper 1,000 feet of the formation is exposed in the mapped area.

The rocks in the Mauch Chunk Formation are mainly red claystone, shale, siltstone, and fine-grained sandstone, but green siltstone and fine-grained sandstone, red or green medium to coarse-grained sandstone, and scattered lenses of gray or green conglomerate are also present. All the beds are lenticular. The contact between the Mauch Chunk and the overlying Pottsville Formation is gradational and is mapped at the horizon below which the beds are predominantly red and above which they are predominantly gray, green, or brown.

Rocks of Pennsylvanian age consist of lenticular beds of conglomerate, sandstone, siltstone, claystone, and shale, interbedded with 12 persistent coal beds and several local coal beds. The lower part of the Pennsylvanian in the mapped area is predominantly conglomeratic, and the upper part is chiefly fine-grained. The coal beds are the most persistent of the lithologic units. The other rock units exhibit so many changes in lithology that they have little value as reference or key beds.

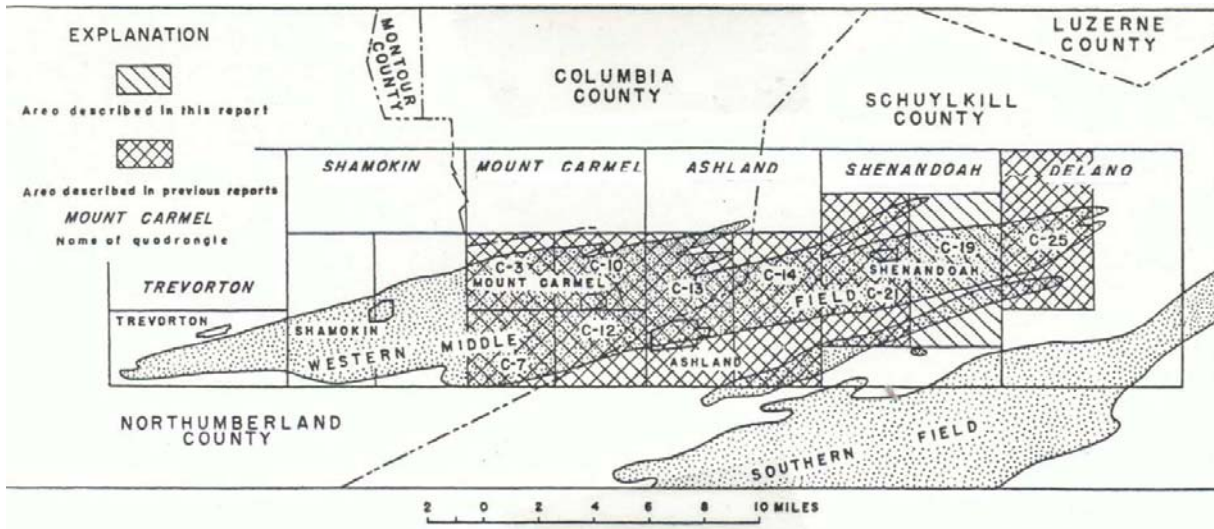

**Figure 7.1.** The eastern end of the Western Middle Anthracite Field, containing the Ellengowan, Knickerbocker, and Shen Penn mines (Danilchik et al., 1955).

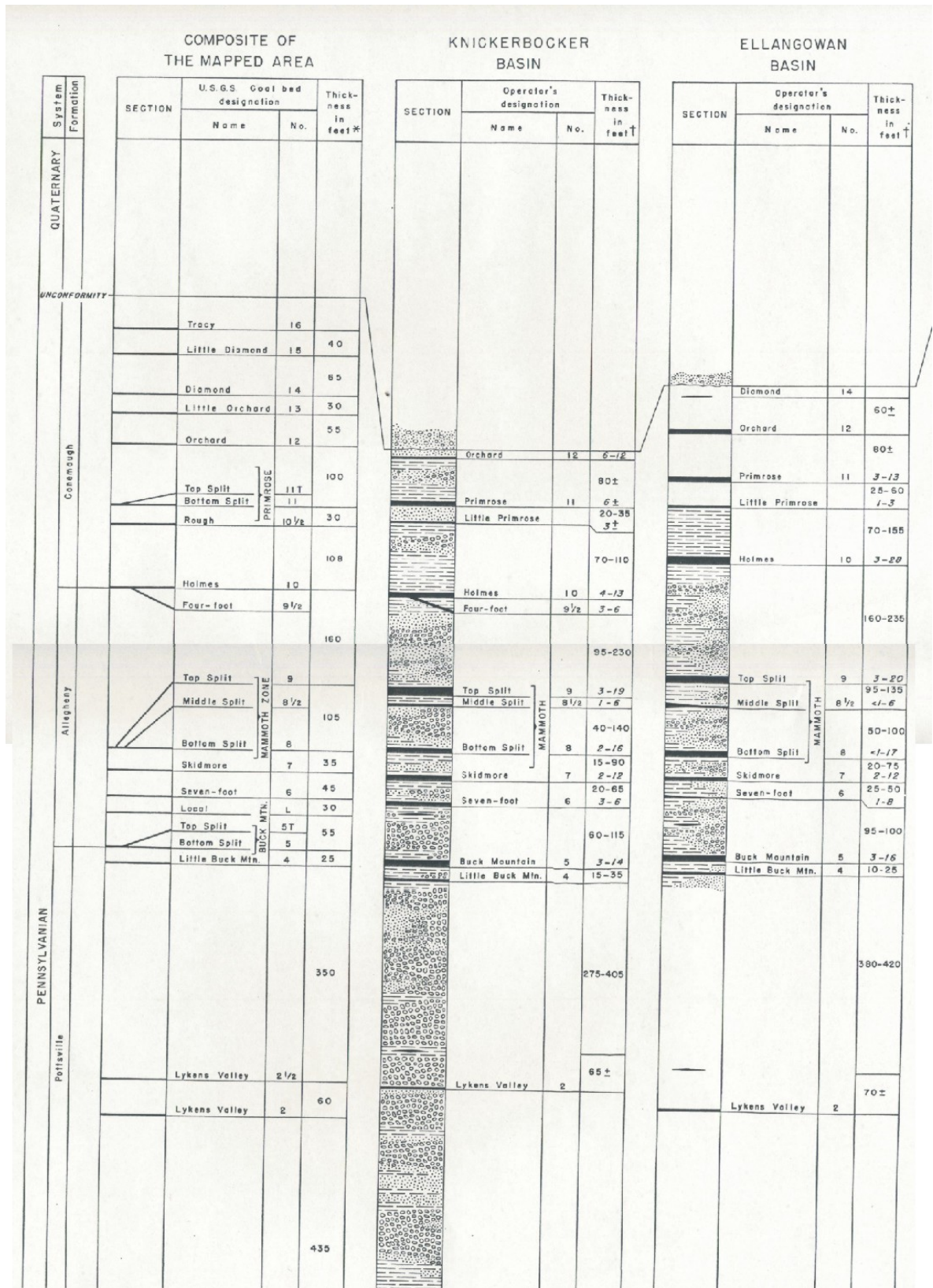

Figure 7.2. Lithologic sections of the Ellengowan and Knickerbocker Basins (Danilchik et al., 1955)

The Pottsville Formation, which includes the oldest rocks of Pennsylvanian age in the area, overlies the Mauch Chunk Formation and underlies the Llewellyn Formation. The Pottsville Formation is composed of beds of gray conglomerate, gray, green, brown, and red sandstone or siltstone and scattered lenses of gray or red claystone. The rest of the formation consists mainly of gray conglomerate, conglomeratic sandstone, coarse- to fine-grained sandstone, and scattered lenses of siltstone and claystone. The Lykens Valley (No. 2 and No. 2 ½) coalbeds are near the middle of the formation. The Little Buck Mountain (No. 4) coal bed is in the upper part of the formation.

The Llewellyn Formation, the base of which is the Buck Mountain (No. 5) coal bed (White, 1900), overlies the Pottsville Formation. The thickness of the Llewellyn Formation ranges from 350 feet in the north to a maximum of 530 feet in the south in this area. The formation is composed of conglomerate, sandstone, siltstone, claystone, and coal. The coal beds are the only laterally persistent lithologic units. In general, conglomerate and sandstone are more abundant in the lower part of the formation. Yellow to light-brown sandstone and siltstone are more abundant in the upper part.

The Llewellyn Formation is the source of most of the coal mined in the area. Six persistent coal beds: the Buck Mountain (No. 5); Seven-foot (No. 6); Skidmore (No. 7); and three beds in the Mammoth coal Zone (No. 8, No. 8 ½, and No. 9) are present in the Llewellyn Formation. The Buck Mountain and Mammoth zone coal beds are economically the most important.

### **7.2.1.2 Structure**

Each of the Pennsylvania Anthracite Fields is a northeast-trending synclinorium composed of several overlapping folds, some of which have been faulted (Fig. 7.3). The area covered by this report is in the eastern part of the synclinorium that constitutes the Western Middle Anthracite Field. The coal-bearing area of the principal component synclines and some of the truncated limbs of these synclines in this field are called basins by the miners and the term is also used in this report. The miners' term "undersheet," which refers to the truncated limb of a syncline that extends beneath an adjacent overlying structure, is also used in this report.

The major basins in the area of discussion are, from north to south, the Knickerbocker, Delano, Maple Hill, Mahanoy City, and Mahanoy Basins. Anticlines separating these basins have been broken by thrust faults, resulting in partial overlaps of the basins (Fig. 7.3). Two small basins, the Locust Mountain Basin in the northern part of the area and the New Boston Basin in the southern part of the area, are separated from the main trunk of the Western Middle Field by the large, unfaulted Locust Mountain and Frackville Anticlines.

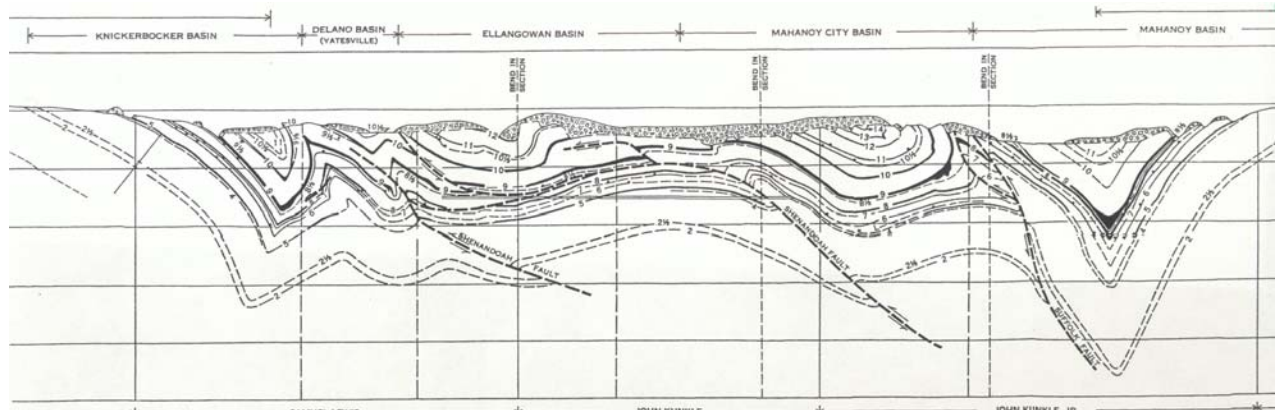

**Figure 7.3.** Cross section through the basins mapped on the eastern edge of the Shenandoah quadrangle (Danilchik et al., 1955).

The Knickerbocker Basin begins in the northwest as a faulted segment of the north limb of the Maple Hill Basin. It ends on the north limb of the Delano Basin. The Delano Basin is a relatively narrow structure that extends to the northeast. This basin lies beneath the Shenandoah thrust fault. A complex shallow syncline, known as the Ellengowan Basin in the thrust plate above the Shenandoah Fault, is present along the south side of the Delano Basin. At the western edge of the area, the westward-plunging Maple Hill Basin is about a mile wide and is one of the broadest basins in the Shenandoah quadrangle. This basin terminates or “spoons” abruptly.

The western end of the Mahanoy City Basin is about a fourth of a mile south of the eastern end of the Maple Hill Basin. The Mahanoy City Basin plunges northeastward. Its southeastern limb is truncated by the Suffolk thrust fault. North of Mahanoy City, this basin is offset by a transverse fault. The Mahanoy Basin is one of the largest and most continuous structures in the Western Middle Field. This basin originates near the center of the field and then extends across the mapped area and eastward to the end of the field. It is the most acutely folded of the major basins. The lowest coal beds in this basin are more than 700 feet below sea level.

The Locust Mountain Basin extends from the west. Only the Lykens Valley (No. 2) and the Little Buck Mountain (No. 4) coal beds are present in this basin in the eastern section of the Shenandoah quadrangle. The New Boston Basin extends diagonally in the south. The basin becomes broader and shallower toward the east. The lower coals of the Llewellyn Formation “spoon out” at the eastern margin of the quadrangle.

The major folds of the eastern part of the Western Middle Anthracite Field trend about N 70° E. In the southern part of the area, the axial planes are inclined approximately 80° to the north. In the northern part of the area, which is more deformed, the axial planes dip 50° to 75° to the south. In the Knickerbocker Basin, however, the axial plane has a north dip at depth and a south dip nearer the surface. The degree of folding, as measured by the least angle between tangents to the limbs of the fold, ranges from 35° to 130°.

Most faults in the eastern section of the Western Middle Anthracite Field are thrust faults that dip southward and are the result of compression. They trend at angles generally less than 60° except where drag has affected the beds. The principal faults, from north to south, are the Delano, Shenandoah, and Suffolk Faults.

The Delano Fault begins in the northeastern part of the area and extends into the adjacent area to the east. This fault is present east of a sharp salient in the Shenandoah Fault north of Mahanoy City, and its development may have been related to a change in amount or direction of displacement on the Shenandoah Fault. The Shenandoah Fault extends into the area from the west, and it terminates in the northeastern part of the area. This is a very irregular fault, as shown on the cross sections. It truncates the southeast limb of the Knickerbocker and Delano Basins.

The Suffolk Fault begins west of the mapped area and extends into the adjoining area on the east. The fault surface, which dips 60° south, truncates the north limb of the Mahanoy Basin. The displacement along the fault ranges from 1,000 feet in the west to 750 feet in the eastern part of the area, with a dip-slip displacement of approximately 450 feet. This displacement brings the Buck Mountain (No. 5) coal bed above the Mammoth Top Split (No. 9) coal bed. Coal beds along this fault have been intensely deformed with the result that, in some places, the coal has been squeezed into relatively thick, irregular pockets and, in other places, coal has been dragged out along the fault into thin sheets of shelly coal.

Several faults in the mapped area cut obliquely across the folds, making angles that range from 40° to 90° with the fold axes. These faults have relatively small displacements that range from a few feet to a few tens of feet. Some of the oblique faults are associated with shear zones in the coal beds. Some of the shear zones may represent transverse faulting in an early stage of development.

Mining is adversely affected by: (1) faults with displacements greater than the thickness of the respective coal bed (called rock faults by the miners); (2) areas in which the coal has been squeezed from between the roof and floor rock (called pinches); (3) small folds that have sheared, thinned, or thickened the coal (called rolls); and (4) shear zones-areas in which the coal is so fractured by differential movement and extreme pressure that it cannot be profitably mined.

### **7.2.1.3 Coal**

In the Western Middle Anthracite Field, the coal beds of the different mines are designated by a number, a name, or both. This nomenclature has not been standardized between the different mines because: 1) coal beds in isolated mines were named before they could be correlated; (2) gaps exist between adjoining workings; (3) the structure and lithology are complex; (4) outcrops are scarce; and (5) once names have been established they tend to be locked into the mining records.

In this chapter, a coal bed is described as persistent, nonpersistent, local, or as a leader. A persistent coal bed can be traced throughout a basin and can be correlated with a bed in the same

stratigraphic position in adjoining basins in the Western Middle field. A nonpersistent coal bed is one that can be recognized and correlated in several of the basins, but is not continuous throughout the basin. A local coal bed is one that cannot be correlated across a basin or between adjoining basins, and generally cannot be traced within a basin for more than 3 or 4 miles. A leader coal bed is one that is: (1) present in only a small area; and (2) where first named it is so near a well-known or economically important coal bed that it serves as a guide or marker for that bed. It may or may not merge into the persistent coal bed and may be separated in some places from the persistent bed by a stratigraphic interval of as much as 40 feet.

Coal beds are rarely exposed in natural outcrops owing to the cover of soil. Listed below are the average thickness and range in thickness of coal beds in the eastern section of the Western Middle Anthracite Field (Table 7.1). Figures on the right half of the table show the thickness of all coal in each bed. Figures on the left half of the table show the thickness of all coal and all shale partings in each bed.

**Table 7.1.** Average thickness and range in thickness of coal beds mined in the eastern part of the Shenandoah quadrangle (Kehn and Wagner, 1955).

Bed #	Thickness												% of refuse				
	Average				Range				Average					Range			
	Ft	In	Ft	In	Ft	In	Ft	In	Ft	In	Ft	In		Ft	In		
16	4	11	4	6	5	2	3	10	3	10	3	10	3	10	22.0		
15	6	0	2	2	10	0	5	4	2	2	8	10	8	10	11.1		
14	7	4	1	0	9	6	7	1	1	0	9	0	9	0	3.4		
13	8	8	4	10	13	0	7	2	4	4	10	0	10	0	17.3		
12	10	4	5	6	14	10	9	1	5	6	14	4	14	4	12.1		
11	8	10	2	8	13	11	7	11	2	8	13	11	13	11	10.4		
10½	3	1	1	0	5	6	2	10	0	11	4	7	4	7	8.1		
10	11	4	2	0	28	0	10	2	2	0	28	0	28	0	10.3		
9½	3	10	1	8	7	11	3	2	0	7	6	5	6	5	17.4		
9	14	1	3	0	41	0	11	1	1	4	32	1	32	1	21.3		
8½	6	5	1	0	27	0	5	2	0	2	21	6	21	6	19.5		
8	10	6	1	0	40	0	9	0	0	6	40	0	40	0	14.3		
7	7	1	1	0	17	11	5	5	1	0	15	2	15	2	23.5		
6	6	4	1	0	15	8	5	5	0	7	13	0	13	0	14.5		
5T			2	6	5	0			0	2	5	0	5	0			
5	12	0	2	10	23	11	9	11	2	7	20	0	20	0	17.4		
44	4	6	1	11	9	7	3	4	1	7	5	7	5	7	25.9		
2½	3	5	1	2	9	7	3	1	1	2	4	8	4	8	9.7		
2	4	11	1	2	11	4	3	4	1	2	11	4	11	4	32.2		

Most of the coal and bed thickness were obtained from mine company data and were chosen to show an average of many underground observations. Measurements of beds that may have been abnormally affected by deformation were not recorded. The maximum and minimum thicknesses shown in this table and in the columnar sections are from all observed measurements along tunnels, mined-coal measurements, drill cores, or sections measured by U.S. Geological

Survey personnel (Kehn and Wagner, 1955). Thickness figures have been omitted from the table where few reliable data are available.

Eighteen coal beds have been mined in the mapped area. Of these, Buck Mountain (No. 5), Seven-foot (No. 6) Skidmore (No. 7), the three splits of the Mammoth coal zone (No. 8, No. 8 ½, and No. 9), and Holmes (No. 10) coal beds are economically the most important.

The Buck Mountain (No. 5) coal bed, basal unit of the Llewellyn Formation, overlies the more resistant rocks of the Pottsville Formation and underlies the remaining beds of the Llewellyn, which are less resistant. As the result of differential resistance to erosion, a topographic bench forms in some areas making it possible to map the outcrop of the Buck Mountain coal bed rather accurately. The persistence, quality, and thickness of this coal bed make it one of the most economically important coals in the area. The Buck Mountain, which is extensively mined, has an average thickness of the coal in each of these beds of 5 feet 5 inches.

The Mammoth coal zone is economically the most important group of coal beds in the Llewellyn Formation. Throughout most of the mapped area, this zone consists of three coal beds or “splits.” These are the Bottom Split (No. 8), Middle Split (No. 8 ½), and Top Split (No. 9). In the southwestern part of the New Boston Basin, the three splits merge and are mined as one bed. The Mammoth coal zone is persistent and is easily identified by its thickness. The Bottom Split (No. 8) coal bed attains a minimum thickness of 40 feet in some parts of the area.

The Holmes (No. 10) coal bed is economically important because of its greater than average thickness (11 feet 4 inches) and its smaller than average percentage of refuse (10.3%). Extensive mine-workings and a uniform interval from the Mammoth coal zone are factors that make the Holmes coal bed useful as a stratigraphic marker. The No. 10 coal bed ranges from 2 feet to 28 feet in thickness in the mapped area.

Several coal beds listed in the table on coal thickness are not described here. These coals are generally of poor quality or of such local occurrence that they were of little economic importance at the time of writing. This, however, does not presuppose that they may not be of greater economic importance as mining practices improve or if the market for coal improves.

### **7.2.2 Mining**

A series of 11 mine maps from the Kehley Run, Indian Ridge, and Shen City collieries covering the stratigraphic interval from the Holmes coal vein down to the Buck Mountain coal (i.e. Holmes, Top Split Mammoth, Bottom Split Mammoth, Skidmore, Seven Foot, and Buck Mountain veins) were obtained from Reading Anthracite Company archives. These maps show the synclinal geologic structure of the Shen Penn Pit and the surrounding area, which plunges to the west and “spoons upward” several hundred feet east of the Shen Penn impoundment. These maps also show that the Buck Mountain coal was only deep mined on the flanks of the syncline (i.e. northern and southern edges of the impoundment), and that the coal is still intact under the center of the Shen Penn Pit near the axis of the syncline. Additional Reading Anthracite Company archives indicate that the Bottom Split Mammoth was the stratigraphically lowest seam removed by surface mining methods in the eastern section of the Shen Penn Pit. Therefore,



the Mammoth vein gangways at the eastern end of the Shen Penn Pit are the most likely outlets for minepool water to flow to adjacent abandoned underground mines to the east.

Figure 7.4 is a cross-section through the Shen Penn with dated intervals showing the location of post-World War II surface mining. The tan line cutting across the blocks represents the current bottom of the surface minepool after surface mining by Reading Anthracite and the extinguishing of the Kehley Run mine fire by the Bureau of Abandoned Mine Reclamation (BAMR).

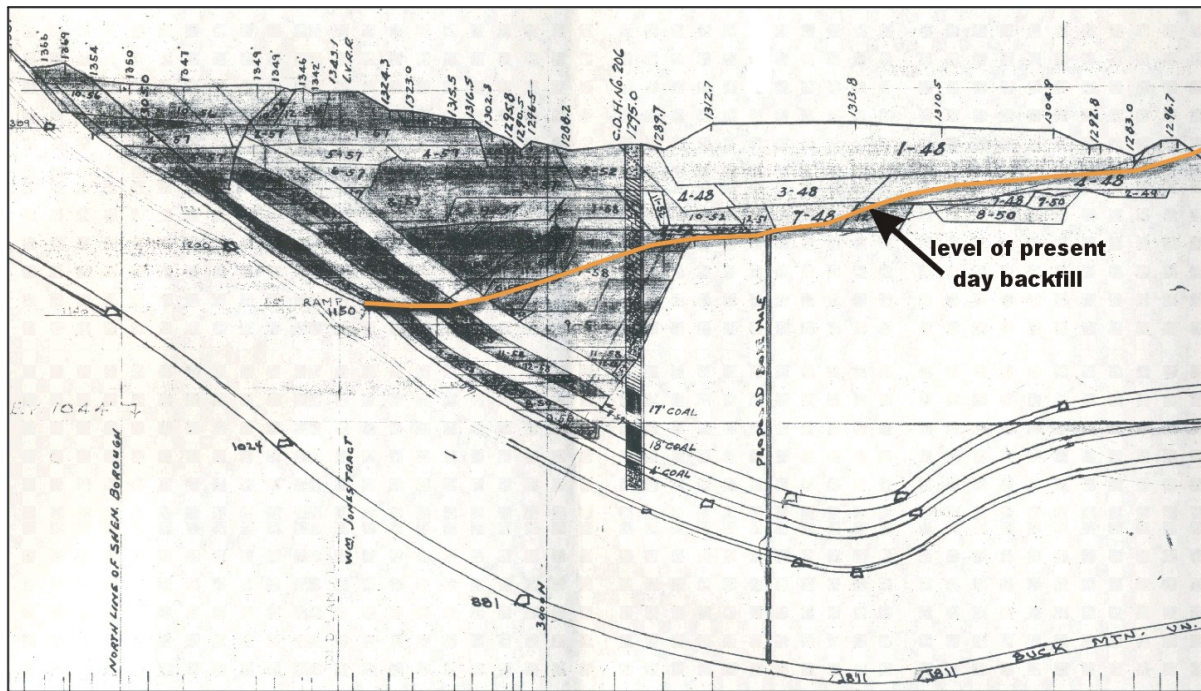
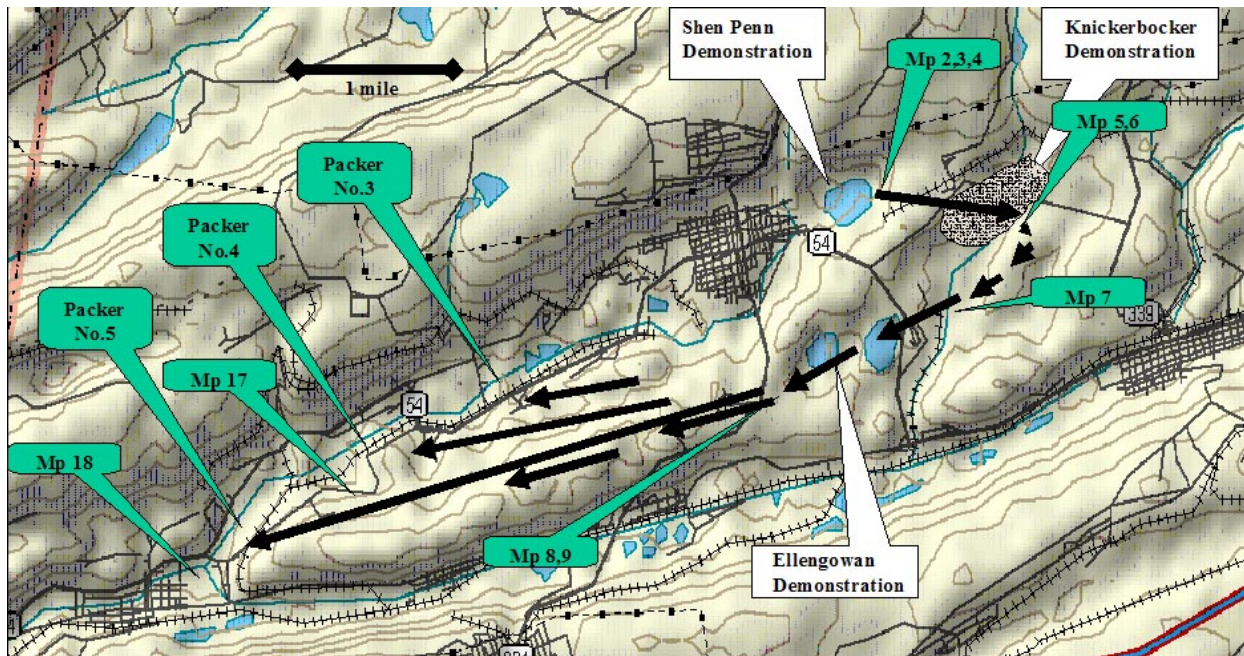

**Figure 7.4.** Cross-section through Shen Penn Pit (48+00E) showing surface mining locations and dates.

### 7.2.3 Subsurface Hydrology

The flow path of the minepool waters from the Shen Penn demonstration project intercepts roughly ten abandoned minepool complexes. The minepool flow path, as determined by the Pennsylvania Department of Environmental Protection (DEP), flows east from the pit underground through abandoned mine workings from the Kehley Run Colliery to the Shenandoah City Colliery, then to the Knickerbocker Colliery. At this point, the pool water flows south through barrier pillar breaches to the Maple Hill Colliery. Whereas, the Shenandoah City mine and Knickerbocker mine pillars have been breached, the flow pattern suggests that the Maple Hill/Mahanoy City pillar may be largely intact, directing the water across the synclinal structure and then westward (Fig. 7.5). The water flows west through the Packer #2, #3, #4, and Hammond Collieries. The minepool flow path continues in the same direction through the Packer 5 Colliery. It discharges to the surface at the Packer 5 airway located at the western end of the town of Girardville and approximately five miles from the Shen Penn Pit. The Packer 5 Mammoth pool discharge point represents the final (and primary) minepool discharge from the Shen Penn, Shenandoah City, Knickerbocker, Maple Hill, Packer 2, 3, 4, Hammond minepool

complexes, and the Shen Penn Pit. The final monitoring point for this water is the Shenandoah Creek (Mp 18) below the confluence with the Packer 5 discharge flow.



**Figure 7.5.** Projected flow path from minepool water discharging from the vicinity of the Shen Penn demonstration site (Laslow, pers. Communication, 2004). (Mp's are relevant DEP monitoring points utilized to establish mine pool flow pattern.)

A small amount of minepool water in this flow system discharges at a large diameter borehole drilled approximately 2500 feet east of Girardville by the Bureau of Abandoned Mine Reclamation (BAMR) in 1973 to eliminate basement flooding in Girardville from rising mine pools, and from the five Lost Creek relief boreholes drilled by BAMR in 1987 (not shown in Fig. 7.5)..

A depth survey conducted across the Shen Penn surface minepool established that the deepest section is approximately 230 feet below the water surface. As typically occurs in anthracite minepools, the minepool is chemically stratified (Fig. 7.6 and Table 7.2). However, the top water does not have a pH as high, and the bottom water does not have sulfate and metal concentrations as high as some minepools in the area. These water chemistry results may reflect the inflow and outflow configuration of the Shen Penn Pit, where the bottom water is higher in sulfate concentration than the top water. However, the outflow allows for some circulation not occurring in other deep minepools. Walter Manhart (Reading Anthracite) and Keith Laslow (DEP) determined that the outlet for minepool flow from the Shen Penn Pit into adjacent abandoned mine workings is at the eastern end of the pit, probably in the Mammoth vein and/or Buck Mountain vein gangways.

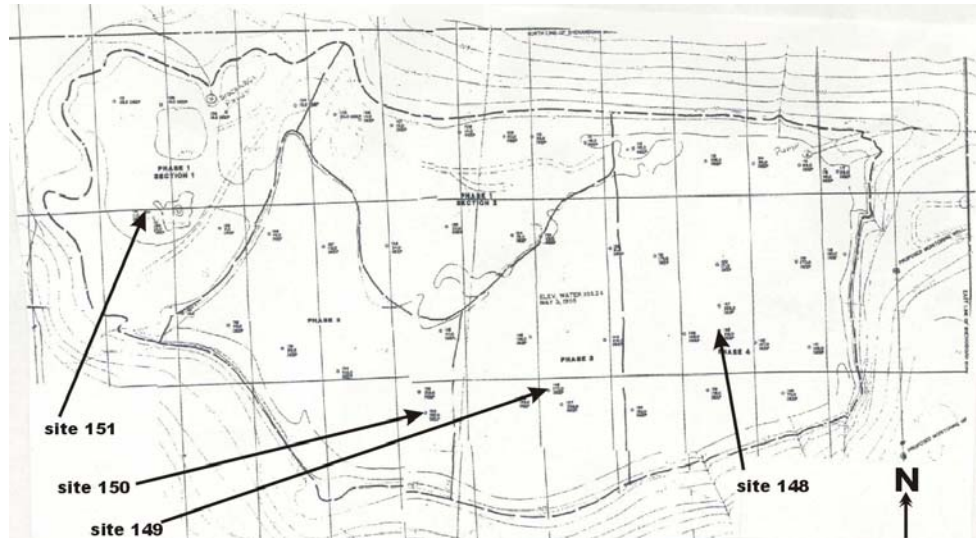

**Figure 7.6.** Shen Penn site map with locations of chemical sampling. The area of open connection to the deep underground mine is to the southeast.

Original minepool data indicated the surface elevation in the Shen Penn impoundment was at 1,103 feet msl prior to the breach in a channel that allowed the Kehley Run water to drain to the pit. A 1994 survey by Walter Manhart showed a surface minepool elevation of 1,132 feet. Given more time, the minepool may eventually return to a level of approximately 1,100 feet msl. Walter Manhart calculated that approximately eight million cubic yards of ash is needed to backfill the Shen Penn Pit to an elevation of 1,140 feet msl.

The significance of the Shen Penn Pit to mineland reclamation in the Commonwealth cannot be over stated. The sheer volume of the pit limits direct funding to backfill it. It is estimated that for just backfilling with rock, the cost would be between \$20 and \$28 million, comparable to the Pennsylvania Bureau of Abandoned Mine Reclamation's annual budget. One way to address such mammoth environmental projects would be to work jointly with industry where there would be sufficient materials available to meet the required volumes of fill.

## 7.3 THE ELLENGOWAN DEMONSTRATION PROJECT

### 7.3.1 Objectives

This study was initiated to provide an independent review of the potential environmental consequences of placing fluidized bed combustor ash directly into standing waters contaminated with acid mine drainage. Two placement techniques were evaluated in the study; direct dry-to-wet and slurry delivered, wet-to-wet placement. The scope of the study included field examination of the emplaced ash, the emplacement method, SPLP evaluation of the leachability of potentially hazardous elements from the ash. The Ellengowan demonstration project was a necessary precursor to the other demonstrations to develop tangible data on a small-scale before embarking on the full-scale demonstrations.

**Table 7.2.** Analytical results for depth sampling of the Shen Penn Pit. Samples collected on 3 May 1995. LD = less than detection. Values for As, Cd, Cr, and Hg were less than the detection level for all samples. Data from DEP\*.

	Cond.	pH	alk/acid	Ca	Mg	Na	Cl	SO <sub>4</sub>	Fe	Mn	Zn	Al
<b>site 148</b>												
surface	312	4.5	6.8/38	20.0	-	-	4	124	0.023	1.35	0.436	1.24
50'	371	4.6	7.4/-	26.7	20.8	4.41	3	162	0.012	1.46	0.452	1.32
100'	836	4.4	7.0/64	72.8	63.6	4.86	2	473	0.100	5.41	0.945	4.40
150'	979	4.2	5.8/68	96.8	65.7	5.73	2	588	0.389	7.39	1.060	4.06
200'	1047	4.6	9.6/100	105.0	73.9	5.40	2	525	17.7	9.87	1.410	4.86
<b>site 149</b>												
surface	312	4.5	6.6/22	20.6	15.6	4.02	4	119	0.021	1.34	0.686	1.14
50'	370	4.6	7.0/20	25.9	19.7	3.92	4	155	0.011	1.50	0.392	1.22
100'	869	4.3	6.8/48	77.8	53.2	4.60	2	456	0.087	5.61	0.950	4.41
150'	1004	4.1	4.6/52	90.8	60.9	4.85	2	546	0.342	6.72	0.936	3.91
200'	1091	4.6	9.0/82	99.0	64.6	4.66	2	589	20.9	9.35	1.300	5.27
<b>site 150</b>												
surface	315	4.5	6.4/20	19.1	15.5	4.05	4	121	0.024	1.39	0.330	1.18
50'	370	4.6	6.8/20	24.4	20.1	3.97	3	155	LD	1.57	0.410	1.21
100'	864	4.3	6.6/48	70.0	52.1	4.75	2	465	0.073	5.75	0.948	4.58
<b>site 151</b>												
surface	312	4.5	6.4/20	19.8	15.8	4.26	4	120	0.028	1.43	0.342	1.22

\* conductivity is in  $\mu\text{S}/\text{cm}$ ; alkalinity and acidity are in  $\text{mg}/\text{L}$   $\text{CaCO}_3$  equivalents, and all other concentrations are in  $\text{mg}/\text{L}$ .

### 7.3.2 Description of the Ellengowan Site

The Ellengowan demonstration was located near what was the small hamlet of Ellengowan just south of the town of Shenandoah and is now included as part of the ash placement site for Schuylkill Energy Resources on the west side of PA route 53. A large silt settling basin was present at this location, which had a 14 acre section along its eastern edge isolated by the construction of a rip-rap dam for this study. The depth of the water in this demonstration cell was approximately 10 feet with the bottom composed of fine coal silt locally referred to as "liver."

### 7.3.3 Ash Characterization

Fly ash and bottom ash were collected at the Schuylkill Energy Resources (SER) facility as individual grab samples before the ash was wetted for transportation to the disposal site. The samples were recovered by an SER employee on 4 December 1994. Since at the facility, the fly and bottom ash are mixed in the relative proportion of 60% fly ash and 40% bottom ash (by volume), all testing was conducted with this ratio.

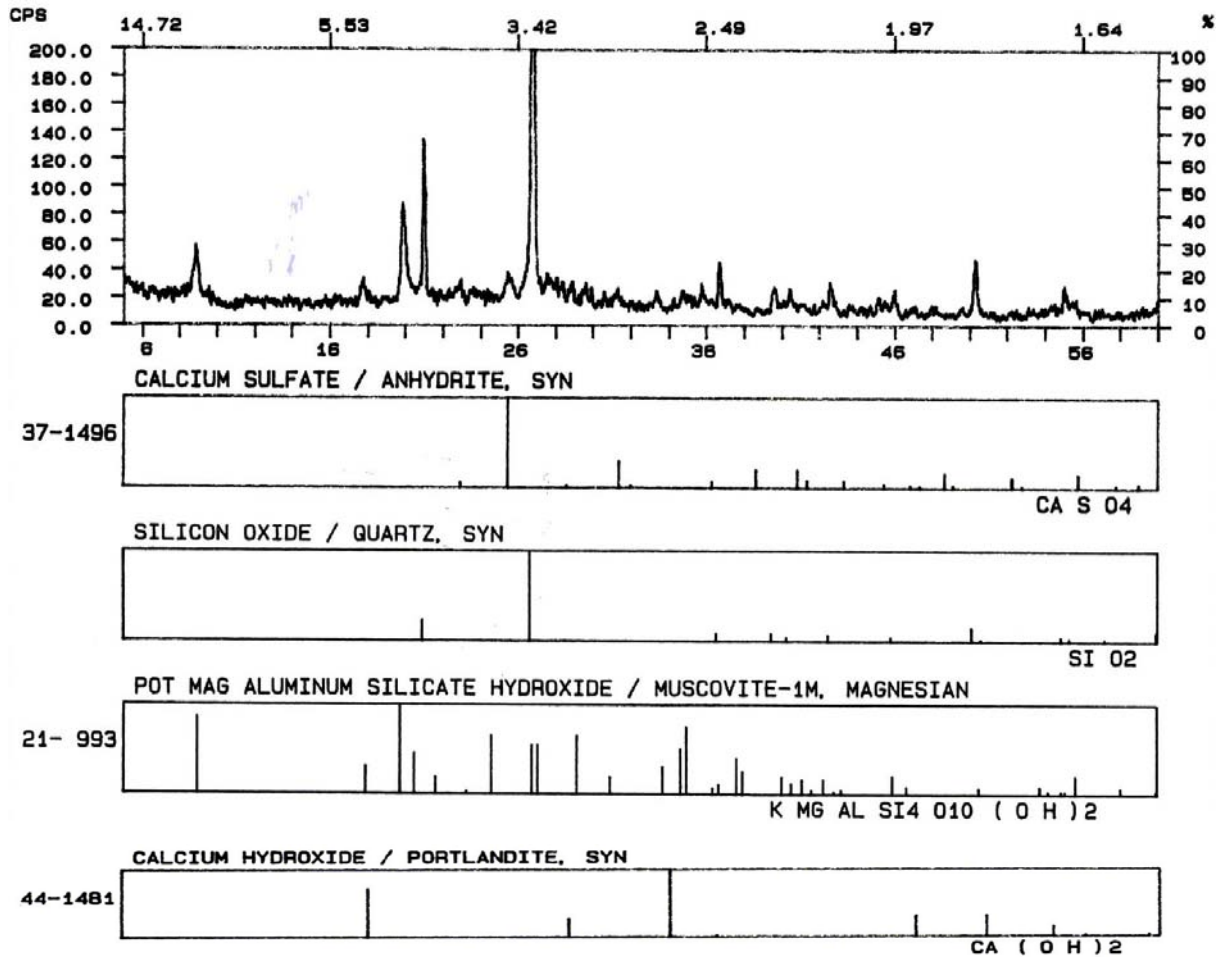

**Figure 7.7.** X-ray diffraction pattern and identified crystalline phases present in SER bottom ash.

X-ray diffraction data collected on the mixed samples of ash indicate that it is a mixture of: 1) predominantly quartz, derived from the anthracite refuse that SER is burning, 2) a clay, also derived from the refuse, 3) portlandite, derived from the hydration of calcined calcite, an added constituent of the fluidized bed, and 4) anhydrite, formed as the result of sulfur reacting with the calcium oxide in the fluidized bed. Figure 7.7 details the raw diffraction data and references it to the ICDD reference patterns for these four phases. The phase identification is consistent with other culm burning facilities with the exception of the clay content that would contribute to some cementitious behavior.

The ash was subjected to testing under the synthetic precipitation leaching procedure (SPLP) (EPA SW-846) protocol required by Module 25 of the DEP to evaluate its potential to release hazardous elements. Table 7.3 summarizes the results of these tests, which show that the ash mixture does indeed pass the regulatory leach test.

The mixture of fly and bottom ash was characterized with regard to its particle size distribution by passing a known mass through a set of sieves. These data are presented in table 7.4. The authors have developed the optimization of particle packing in order to achieve

maximum density with dry concrete mixes with the purpose of enhancing durability of the concrete. As part of this research activity, a PC-based computer code has been developed and utilized which accurately predicts the maximum packing density that may be anticipated from a material based on the sieve analysis. From these data in table 7.4, the model predicted that the maximum dry particle packing that may be anticipated for the SER ash mixture is about 60 to 62 percent of theoretical density. The theory underestimated the observed densities that routinely approached 90% for both the slurry placed and vehicle compacted ash.

**Table 7.3.** Chemical Analysis of SPLP Leach Test.

Element	mg/L	element	mg/L	element	mg/L
Ag	<0.02	Hg	<0.002	Sr	1.55
Al	0.37	K	8.0	Ti	<0.02
As	<0.01	Mg	0.05	Tl	0.06
B	0.02	Mn	<0.02	V	0.06
Ba	0.11	Mo	0.12	Zn	<0.02
Be	<0.02	Na	3.74	Zr	0.05
Ca	420	Ni	0.05	CN	<0.1
Cd	<0.02	Pb	<0.01	Cl	0.6
Co	0.06	Sb	0.01	NO <sub>3</sub>	1.2
Cr	0.15	Se	0.02	SO <sub>4</sub>	1080
Cu	<0.02	Si	4.5	pH (init.)	4.22
Fe	0.02	Sr	1.55	pH (final)	12.07

**Table 7.4.** Sieve Analysis 60:40 Mix Schuylkill Energy Resources Ash.

Sieve size	% retained	Sieve opening
¼ inch	0	2540µm
#4	2.08	4760µm
#8	13.74	2360µm
#16	14.75	1180µm
#30	5.02	600µm
#40	1.13	425µm
#60	1.53	250µm
#100	24.40	150µm
#140	20.78	105µm
#200	7.31	74µm
#270	3.97	51µm
#325	2.36	45µm
Pan	1.00	

### 7.3.4 Field Observations

The mixture of ashes was slurry pumped into 7 feet of standing water in a silt pond, as well as end-dumped into the standing water. The results of these observations were very encouraging, and are as follows.

#### 7.3.4.1 End-dumped ash

Ash was placed into the standing water while still hot. The surface level of the ash was approximately 3 feet above the current water level. The ash compacts well under the normal operation of the heavy equipment. Two test pits were dug into the ash that had been in place for approximately 1 month (SER personnel). One pit was at the deepest portion of the silt pond and approximately 30 to 40 feet from the water's edge, while the other pit was placed about 10 to 15 feet from the water's edge. Both pits were dug to the silt "liner" interface and were found to be dry. The walls possessed sufficient strength that they held their form without any evidence of collapse. Figure 7.8 is a photograph taken at the time the pit was dug showing the competent structure of the pit walls. These observations suggest that the ash has successfully displaced the water and that, within the time frame of the observations, the water had not infiltrated back into the ash pile.

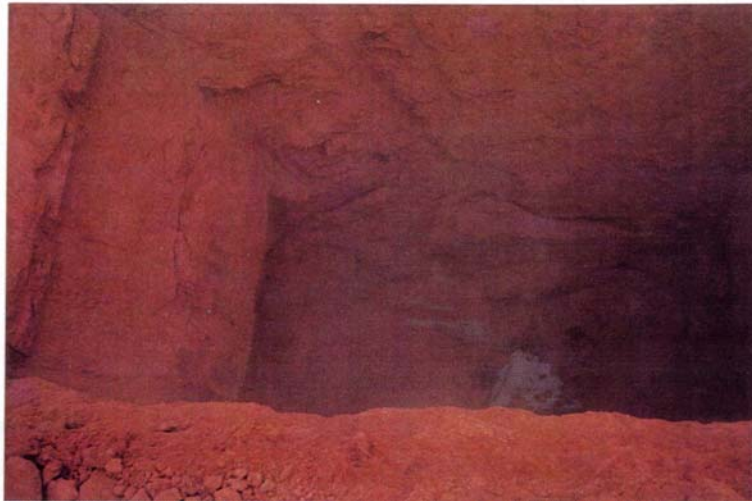

**Figure 7.8.** Photograph of test pit dug into end dumped ash. Note the wall structure and the presence of water at the silt/ash interface.

#### 7.3.4.2 Pumped ash slurry

The photograph in figure 7.9 presents an overview of the slurry activities into the test pond. Two observation points were examined, one on the initial pumping site and the other near the site of the test pits. At the initial site, the level of the placed ash was less than a foot above the water level of the pond. A shovel test (dug by hand) revealed the saturation level at a depth of about 2 feet and, just like the beach, this hole gradually collapsed upon itself. This observation had prompted the request from DEP to dig the two test pits discussed above.

The second site had significantly more ash placed during our observation. Very limited turbidity was observed in the pond water, and only occurred in the shallow waters where the ash entered the pond after running over the previously placed material. It is important to prevent the fines from mixing with the pond water and forming a "mud puddle." Hence, slurryed ash should be placed in a non-turbulent manner as was practiced and observed in this demonstration. The

ash slurry should not be dropped into the water, especially deep minepool impoundments like Shen Penn.

A second visit was made to the site on 20 August 1995 to examine the portion of the pond that had been completed by slurring ash into the standing water. The surface appeared competent and had supported the weight of large equipment. Figure 7.10 is a photograph of a D8 driving on the slurried surface. As in our previous visit, a test pit was dug into the ash to examine the compaction of the ash. During this exercise, the operator of the GradeAll experienced difficulty in digging through compacted ash. The resulting hole was similar in appearance to those observed previously, showing no slumping of the side walls and containing water only at the contact between the underlying “liner” and the deposited ash. Because the conditions of the slurried ash were similar to those previously observed, no additional holes were dug. A portion of the hardened slurried ash was a prominent white effervescent deposit which was determined by XRD to be a mixture of gypsum [ $\text{CaSO}_4 \cdot 2\text{H}_2\text{O}$ ] and syngenite [ $\text{K}_2\text{Ca}(\text{SO}_4)_2 \cdot \text{H}_2\text{O}$ ].



**Figure 7.9.** Photograph of the slurry placement facility.

### 7.3.5 Fly Ash- Grout Development

The field experiments with placement of the unconsolidated fly ash have been very promising, but as a fall-back position, a cementitious grout based on the alkali activation of the SER ash was pursued. In contrast to what was observed in the field, preliminary scooping studies in the laboratory have shown that the mixture of fly and bottom ash by itself does not possess enough pozzolanic activity to effectively consolidate. The difference in these two observations can be traced to the placement of “hot” ash in the field, which accelerates the hydration reactions when contrasted to cooled ash in the laboratory. Studies have shown that activation can be achieved with the use of both a waste baghouse lime dust (LKD) or a waste baghouse cement kiln dust (CKD).



Laboratory data for the lime dust are very promising at early hydration times, yielding an unconfined compressive strength of 1153 psi, but as the hydration process continues, strength begins to decrease to a value of 400 psi at 90 days, (Fig. 7.11 and Table 7.5). The grout was prepared with a water to cement ratio of 0.21, which is quite a bit lower than 0.5, the ratio that is being used in the slurring operation. The lime dust loading is 3.76 %wt. The addition of the lime dust obviously assisted in the relatively high early strength of this formulation, but it is believed that there was insufficient lime to maintain the chemical reactions associated with the hydration that was initiated. X-ray diffraction characterization of the 90-day cured grout and the ash recovered from the slurry demonstration show very little difference in bulk mineralogy, with the latter sample appearing to contain more amorphous materials than the grout (Figs. 7.12 panel a and panel b). The ability of the grout to transmit water was measured on the 56 day specimen and found to be  $1.19 \times 10^{-4}$  darcys ( $1.16 \times 10^{-7}$  cm/sec), a value comparable to that of compacted clay.



**Figure 7.10.** A D8 operating on the surface of the slurry-placed ash after closure of the demonstration pond.

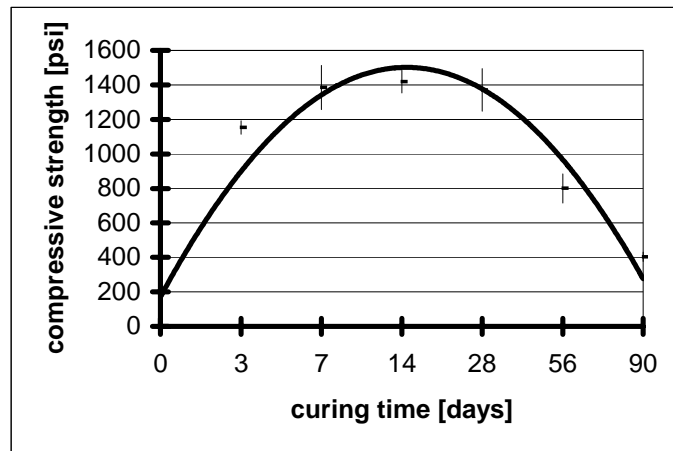

**Figure 7.11.** Strength development in lime kiln dust (LKD) activated fly ash grout as a function of curing time.

**Table 7.5.** Unconfined compressive strength of LKD activated fly ash grouts as a function of time.

Curing Time (days)	Compressive Strength (psi)	Standard Deviation
3	1153	39.6
7	1385	128.4
14	1419	65.3
28	1371	122.7
56	800	83.8
90	403	27.5

Two samples of cement kiln dust were received from a cement manufacturer near Nazareth, PA. One sample was wet and the other was dry. Experience at PSU has been that wet CKD samples have little or no activation potential for fly ash grout formulations, therefore it was eliminated for further consideration. A formulation was chosen which utilized 14.8 %wt CKD with a water to solids ratio of 0.26. Preliminary mix design data were not very encouraging. Strength development with this mixture was limited to less than 200 psi in 28 days of curing (Fig. 7.13 and Table 7.6). Although CKD could be utilized, larger amounts of materials would be needed and the resulting quality of the grout would need additional evaluation for the cost effectiveness of its use. Another lime source that has potential for use as an activator with this class of fly ash is lime kiln dust (LKD). Lime kiln dust has the advantage of containing free lime which offers a significant benefit from its enhanced chemical reactivity. However LKD has the same drawback as CKD in that it must be obtained ‘fresh’ to take advantage of its benefits. Upon exposure to weathering, it too will adsorb carbon dioxide from the air and greatly reduce its function as an activator.

### 7.3.6 Ash Strength

With the slurry placement of the SER ash, a concern has been raised about the required minimum bearing strength for this ash. There are two reasons: 1) operations logistics require that it support heavy vehicles and 2) post placement usage for ultimate load, not quick sand. Clearly from Figure 7.10 the ash slurried into the demonstration pond was compacted enough to support the mass of this heavy tracked vehicle. Quantification of compaction of soils in general assumes that a wheeled vehicle would contact the uncompacted soil in circular pattern of diameter,  $D$ , and a load from the vehicle,  $L$ . The simple mass per unit area relationship can then be used to describe the compaction force on the soil once the buoyant effects of contacting soil particles are factored into the calculation. The buoyant effects act as a proportionality constant, which varies as a function of soil depth. Figure 7.14 includes a schematic drawing detailing these relationships. Table 7.7 and Figure 7.14 summarize calculated data for the example of a 10 inch wide tire on a vehicle with a load of 4,710 pounds per wheel. This simple calculation suggests that for a wheeled vehicle to traverse a freshly placed soil a minimum bearing strength of 36 psi would be necessary to allow the vehicle to pass. Following similar reasoning, the alleviation of soils compaction in agriculture application has been studied as a function of the tire width and diameter, ply structure, tire inflation pressure, and gross vehicle weight. The variation of surface pressures for these varying parameters, presented for the range of conventional construction vehicles, also suggests that a minimum of 30 psi is necessary to support the mass of a conventional vehicle, in agreement with the data calculated in the previous analysis.

a)

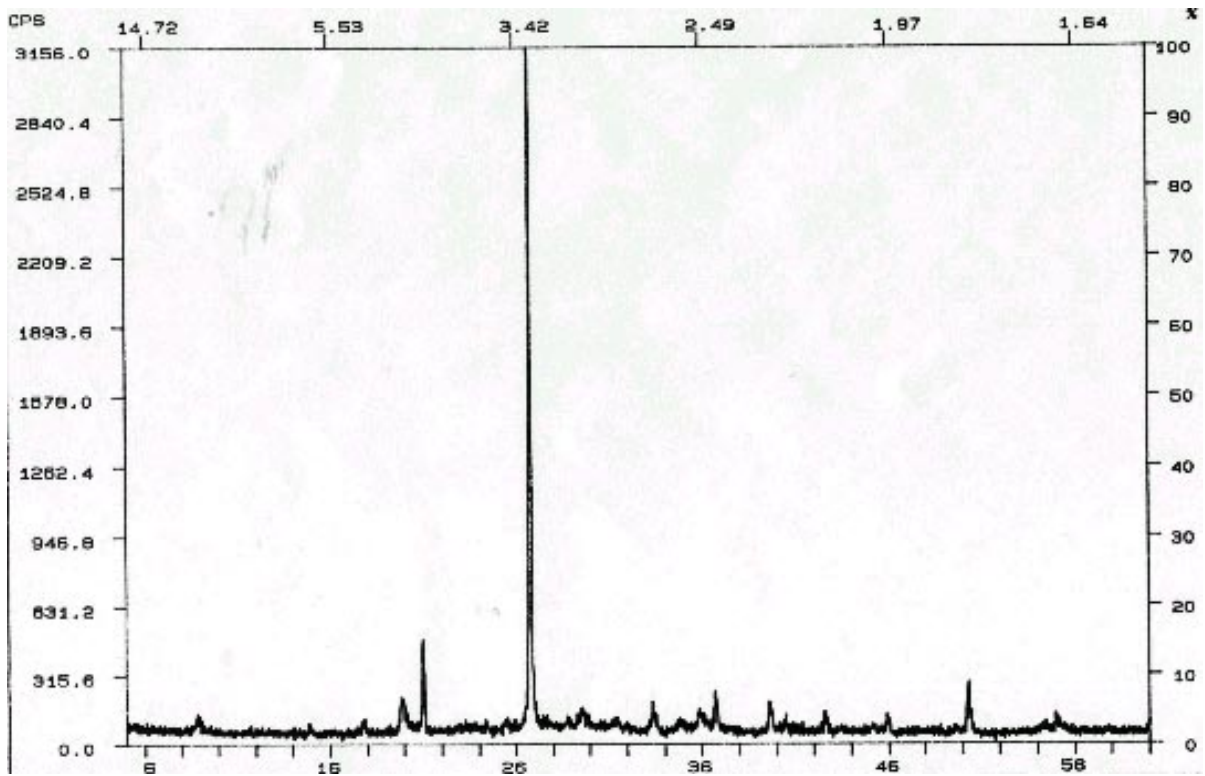

b)

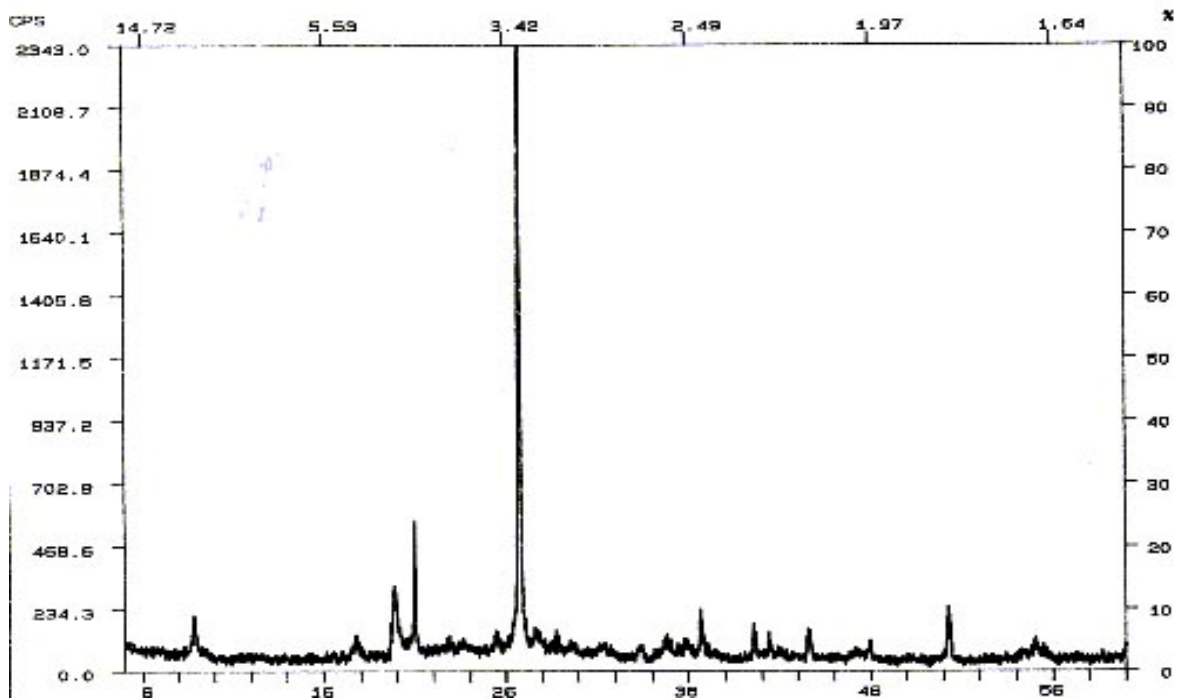

**Figure 7.12.** X-ray diffraction pattern for a) fly ash grout cured for 90 days and b) slurry placed fly ash.

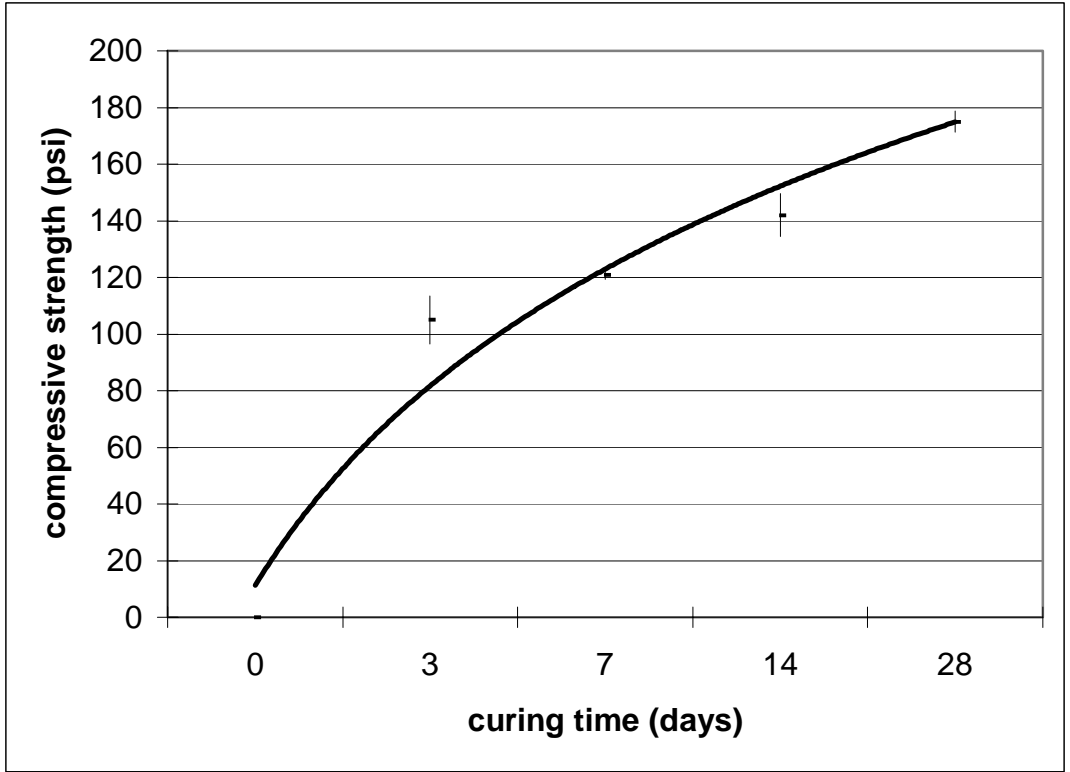

**Figure 7.13.** Strength development in CKD activated fly ash grout as a function of curing time.

**Table 7.6.** Unconfined compressive strength of CKD activated fly ash grouts as a function of time.

Curing Time (days)	Compressive Strength (psi)	Standard Deviation
3	105	8.5
7	121	1.7
14	142	7.6
28	175	3.8

**Table 7.7.** Variation in compaction pressure with depth under a load.

**Example:** **D = 10 in**  
**L = 4,710 pounds**  
**A = 78.5 in<sup>2</sup>**  
**P = 4,710/78.5 = 60 psi**

Distance under surface (inches)	Proportionality Factor	Soil Pressure (psi)
0	1.00	60.0
5	0.60	36.0
10	0.30	30.0
15	0.15	9.0
20	0.09	5.4

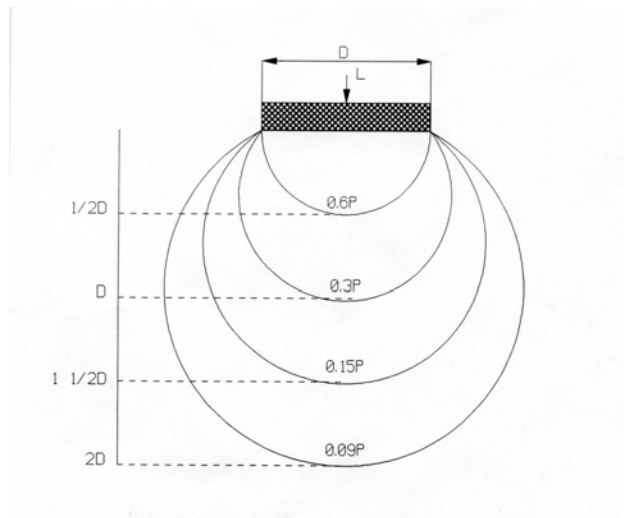

**Figure 7.14.** Variation in compaction pressure with depth under a load.

### 7.3.7 Recommendations

Slurry placement appears, by all observations in this demonstration, to be an adequate approach, if the slurry is allowed to flow into the standing water in a slow delta-like spreading flow. That is to say, the slurry should be allowed to flow as gently as possible into the water. This placement approach is recommended to best minimize turbulent mixing and the formation of turbidity. Under no circumstances should the slurry be “dropped” into the standing waters.

The behavior in deep waters approaching 50 to 250 feet of water can only be speculated from this demonstration. The advancing front of ash in the deep water would establish a subaqueous angle that may contribute to fine particle segregation resulting in high turbidity water. The possibility of subsurface placement of the ash near the bottom of the pit should be considered. Should segregation of the ash occur, resulting in excessive turbidity (a muddy appearance), the placement should be temporarily halted and the process re-evaluated and an alternative placement approach considered.

The slurried ash appears to be compacted enough to support the mass of heavy construction tracked vehicles. Quantitatively, the strength needed in the placed ash appears to be a minimum of 30 to 35 psi in order to support vehicular traffic.

If at some future point, it becomes necessary to further stabilize the FBC ash for placement, the preliminary studies support the observations that cementitious grouts can be formulated by the addition of lime kiln dust. The long-term strength performance of the formulation, chosen in this study, does however point out the necessity for additional detailed studies. Grouts formulated with cement kiln dust may also provide an alternative activation source but at the expense of lower strength and larger amounts of activator additions and

enhanced materials handling. The hydraulic conductivity ( $10^{-7}$  cm/sec) of the grout appears to be well within the range of clay sealants and in agreement with the field observations from the test pits.

## **7.4 THE SHEN PENN DEMONSTRATION PROJECT**

### **7.4.1 Objectives**

The Shen Penn Pit represents a significant public health and safety problem directly to the city of Shenandoah and surrounding communities because it is often used as a recreational swimming hole and is the site of multiple drowning fatalities. The most recent being an 11 year boy triggered a renewed interest in eliminating the safety problem with the water-filled pit. The objective of the demonstration was to show that ash could be transported in the form of a slurry and placed in the deep standing waters of the Shen Penn Pit.

### **7.4.2 Description of the Shen Penn Site**

The Shen Penn Demonstration represents the one of three demonstration permits issued by the DEP for the purpose of establishing the efficacy of ash placement into mine waters. This permit was intended to evaluate the so-called wet-to-wet placement in which ash from the Schuylkill Energy Resources Cogeneration facility would be placed as a slurry into the mine pit water. The permit was issued to Reading Anthracite Company as DEP Waste Demonstration Permit # 301289 on the 22<sup>nd</sup> October 1995 to include a project area of 49 acres.

The Shen Penn Pit is located within the town of Shenandoah on the eastern end of town and encompasses approximately 39 water filled acres with a measured depth of 240 feet. Associated with the pit is an exposed highwall approaching 600 feet. Figure 7.15 is an aerial overview of the pit and its relationship to the cogeneration facility and the town of Shanendoah.

### **7.4.3 Proposed Ash Placement**

The ash is generated from Schuylkill Energy Resources Cogeneration Plant at the rate of approximately 100 tons per hour. The ash is a mixture of bottom ash and fly ash of approximately 60/40%, respectively. The ash would be slurried from the plant at a 20:80 solid to water ratio. The water required for the slurry system would be pumped from the Shen Penn Pit, however, current plant mine water, and/or cooling tower blowdown water would be utilized when maintenance on the pipeline is required. The arrangement would consist of a mixing tank and (2) 10 inch diameter polyethylene pipelines approximately 7,000 feet in length. It is anticipated that provisions would be made for the installation of a slurry pump adjacent to the mixing tank, if necessary. If in the event of a slurry pipeline blockage or repairs, the ash would be disposed at the present ash disposal site.



**Figure 7.15.** Aerial photograph of the Shen Penn Pit in relation to the Schuylkill Energy Resources Cogeneration facility and to the town of Shenandoah to the west of the pit.

The pipeline would be fed by a mixing tank located on the ash silo operating floor. Future consideration on collecting the ash within the cogeneration plant would likely be the preferred choice. This would eliminate the transfer of ash from the ash coolers to the silo. Water would be fed to the mixing tank at a rate of 1,600 gallons per minute (gpm). The slurry flow rate would be approximately 1,850 gpm. A float valve would be used to maintain the water level in the mixing tank. One pipeline would be used for conveying ash and the second pipeline would be used for return water from the Shen Penn Pit to the power plant.

The pipeline may contain only three or four elbows. Connections would be fused together to eliminate the potential for ash leakage. The elevation change in the first 3,000 feet of pipeline would be approximately 62 feet. This may allow the slurry to be conveyed by gravity, however, provisions would be made for the possible installation of a slurry pump adjacent to the mixing tank. No unmanageable problems with leaks are expected, since the pipeline would be operated under low pressures (typically less than 15 psi). The last 4,000 feet of pipe would have adequate head to transport the slurry. The final 4000 feet of pipeline would operate under vacuum and be equipped with vacuum breakers. Any leaks that develop would draw air into the pipeline and not result in ash leaks. A booster pump would be operated to clean the pipeline if it starts to plug. Ash would be disposed at the existing permitted ash disposal area if the slurry pipeline is unavailable.

The first phase of ash placement would be located at the northwest corner of the Shen Penn Pit. The water is approximately 20 feet deep at this location. The slurry pipeline discharge point would be approximately 10 feet back from the shoreline at the current water elevation. The discharge pipe elevation and distance from the shoreline may require adjustments in order to

maintain proper flow characteristics. Proper flow regime would enable the ash to settle on a gentle slope under the water and assure greater stability as the ash placement progresses.

Ash placement would proceed in each phase to an elevation above the water that would support heavy equipment, which is required to extend and/or move the pipeline. The mechanism to extend the pipeline is essentially an iron to heat fuse additional lengths of pipe and elbows. Since the pipe is flexible, a crawler dozer may be required to move the discharge point a short distance. If the pipeline needs to be raised, a dozer would be utilized to lift the pipe and support would be placed underneath.

It was agreed that the ash was not required to set up in water like concrete, but must have some reasonable expectation for stability in order to proceed with work on the final ash surface and to drive heavy equipment on that surface. Therefore, the bearing capacity at the ash surface is a more significant measurement than to what extent the ash exhibits pozzolanic properties. William Pounds of the Bureau of Land Recycling and Waste Management developed the following operational definition: "The fly ash must solidify by a chemical or physical process concurrently with addition to the pit, or within the shortest period of time technologically practicable. The fly ash must solidify prior to filling the pit above the water level, and tests should be conducted to demonstrate that the fly ash is stable. The fly ash in the pit, after meeting this requirement, must be capable of withstanding a minimum bearing capacity of 1.5 tons per square foot." Another condition is that subaqueous ash must not leach or migrate from the Shen Penn Pit into adjacent abandoned underground mines.

The ash would be chemically and physically analyzed as per Module 25 requirements. Additional physical analysis would be conducted periodically regarding saturation and compaction. This testing would be conducted by augering, drilling (split spoon), and/or excavation, whichever is most efficient. Water monitoring would be conducted within the pit (in advance of the ash placement), the proposed monitoring wells, existing wells, and surface flows. The monitoring frequencies and parameters would be further defined once the project has commenced.

Upon successful completion of the entire project, the ash would be covered with three feet of intermediate cover and one foot of final cover and graded to blend with the existing topography. Once final cover grading is completed for the final land use, planting of trees and grasses would finish the reclamation at the Shen Penn Pit. Final completion of the reclamation would result in 40 acres of developable land.