



SECTION A. Table of Contents

Section A. Facility/Source Identification

Table of Contents
Site Inventory List

Section B. General Title V Requirements

- #001 Definitions
- #002 Prohibition of Air Pollution
- #003 Property Rights
- #004 Permit Expiration
- #005 Permit Renewal
- #006 Transfer of Ownership or Operational Control
- #007 Inspection and Entry
- #008 Compliance Requirements
- #009 Need to Halt or Reduce Activity Not a Defense
- #010 Duty to Provide Information
- #011 Reopening and Revising the Title V Permit for Cause
- #012 Reopening a Title V Permit for Cause by EPA
- #013 Operating Permit Application Review by the EPA
- #014 Significant Operating Permit Modifications
- #015 Minor Operating Permit Modifications
- #016 Administrative Operating Permit Amendments
- #017 Severability Clause
- #018 Fee Payment
- #019 Authorization for De Minimis Emission Increases
- #020 Reactivation of Sources
- #021 Circumvention
- #022 Submissions
- #023 Sampling, Testing and Monitoring Procedures
- #024 Compliance Certification
- #025 Recordkeeping Requirements
- #026 Reporting Requirements
- #027 Operational Flexibility
- #028 Risk Management
- #029 Approved Economic Incentives and Emission Trading Programs
- #030 Permit Shield
- #031 Reporting
- #032 Report Format

Section C. Site Level Title V Requirements

- C-I: Restrictions
- C-II: Testing Requirements
- C-III: Monitoring Requirements
- C-IV: Recordkeeping Requirements
- C-V: Reporting Requirements
- C-VI: Work Practice Standards
- C-VII: Additional Requirements
- C-VIII: Compliance Certification
- C-IX: Compliance Schedule

Section D. Source Level Title V Requirements

- D-I: Restrictions
- D-II: Testing Requirements
- D-III: Monitoring Requirements
- D-IV: Recordkeeping Requirements
- D-V: Reporting Requirements



SECTION A. Table of Contents

D-VI: Work Practice Standards
D-VII: Additional Requirements

Note: These same sub-sections are repeated for each source!

Section E. Source Group Restrictions

E-I: Restrictions
E-II: Testing Requirements
E-III: Monitoring Requirements
E-IV: Recordkeeping Requirements
E-V: Reporting Requirements
E-VI: Work Practice Standards
E-VII: Additional Requirements

Section F. Alternative Operating Scenario(s)

F-I: Restrictions
F-II: Testing Requirements
F-III: Monitoring Requirements
F-IV: Recordkeeping Requirements
F-V: Reporting Requirements
F-VI: Work Practice Standards
F-VII: Additional Requirements

Section G. Emission Restriction Summary

Section H. Miscellaneous

**SECTION A. Site Inventory List**

Source ID	Source Name	Capacity/Throughput		Fuel/Material
031	BOILER 1 WITH LOW NOX BURNER	8,717.000	MMBTU/HR	
		335.300	Tons/HR	COAL
		63.170	Th Gal/HR	NO. 2 FUEL OIL
032	BOILER 2 WITH LOW NOX BURNER	8,717.000	MMBTU/HR	
		335.300	Tons/HR	COAL
		63.170	Th Gal/HR	NO. 2 FUEL OIL
037	AUX BOILER A	138.000	MMBTU/HR	
		1.000	Th Gal/HR	NO. 2 FUEL OIL
038	AUX BOILER B	138.000	MMBTU/HR	
		1.000	Th Gal/HR	NO 2. FUEL OIL
115	FIRED SPACE AND MISCELLANEOUS HEATERS	4.400	Gal/HR	Propane
101	UNIT 3 PEAKING DIESEL GENERATOR (3,600-BHP)	216.000	Gal/HR	#2 Oil
102	UNIT 4 PEAKING DIESEL GENERATOR (3,600-BHP)	216.000	Gal/HR	#2 Oil
103	UNIT 5 PEAKING DIESEL GENERATOR (3,600-BHP)	216.000	Gal/HR	#2 Oil
104	UNIT 6 PEAKING DIESEL GENERATOR (3,600-BHP)	216.000	Gal/HR	#2 Oil
105	PLANT HAUL ROADS		N/A	
106	COAL HANDLING	750.000	Tons/HR	
107	ASH DISPOSAL	500.000	Tons/HR	
108	FUGITIVE VOC/HAPS	100.000	Gal/HR	
109	NATURAL DRAFT COOLING TOWERS		N/A	
110	EMERGENCY ENGINES (910HP GEN, 217 & 200HP FIRE PUMPS)	81.000	Gal/HR	DIESEL
111	LIMESTONE HANDLING, PROCESSING, AND STORAGE OPERATIONS	74.850	Tons/HR	LIMESTONE
112	GYPSUM PRODUCTION, PROCESSING, AND HANDLING OPERATIONS	999.000	Tons/HR	GYPSUM
113	EMERGENCY QUENCH PUMPS/ENGINES (2-130HP & 2,328-BHP)	140.000	Gal/HR	Diesel Fuel
114	EMERGENCY DIESEL GENERATOR (1,474-BHP ENG., 1,000-KW OUTPUT)	74.000	Gal/HR	Diesel Fuel
116	SORBENT HANDLING AND STORAGE	250.000	Lbs/HR	CALCIUM HYDRATE/UNIT
C01	BOILER 1 ESP			
C02	BOILER 2 ESP			
C031	BOILER 1 FLUE GAS DESULFURIZATION SYSTEM			
C032	BOILER 2 FLUE GAS DESULFURIZATION SYSTEM			
C116	SORBENT INJECTION STORAGE BIN VENT			
C31A	BOILER 1 SCR SYSTEM			
C31B	BOILER 1 SORBENT INJECTION SYSTEM			
C32A	BOILER 2 SCR SYSTEM			
C32B	BOILER 2 SORBENT INJECTION SYSTEM			
FM001	COAL STORAGE PILES			
FM002	MAIN #2 FUEL OIL STORAGE TANKS			
S03	DIESEL 3 STACK			

SECTION A. Site Inventory List

Source ID	Source Name	Capacity/Throughput	Fuel/Material
S04	DIESEL 4 STACK		
S05	DIESEL 5 STACK		
S06	DIESEL 6 STACK		
S07	AUX BOILER STACK		
S113	EMERGENCY QUENCH PUMPS/ENGINE STACK		
S114	EMERGENCY DIESEL GENERATOR STACK		
S115	MISCELLANEOUS HEATER STACKS		
S116	SORBENT INJECTION STORAGE STACK		
S12	MAIN STACK FOR BOILERS 1 AND 2		
Z10	EMERGENCY ENGINE STACKS		
Z108	FUGITIVE VOC/HAPS		
Z110	FUGITIVE DUST		
Z111	LIMESTONE PROCESSING FUGITIVE EMISSIONS		
Z112	GYPSUM PROCESSING FUGITIVE EMISSIONS		

PERMIT MAPS

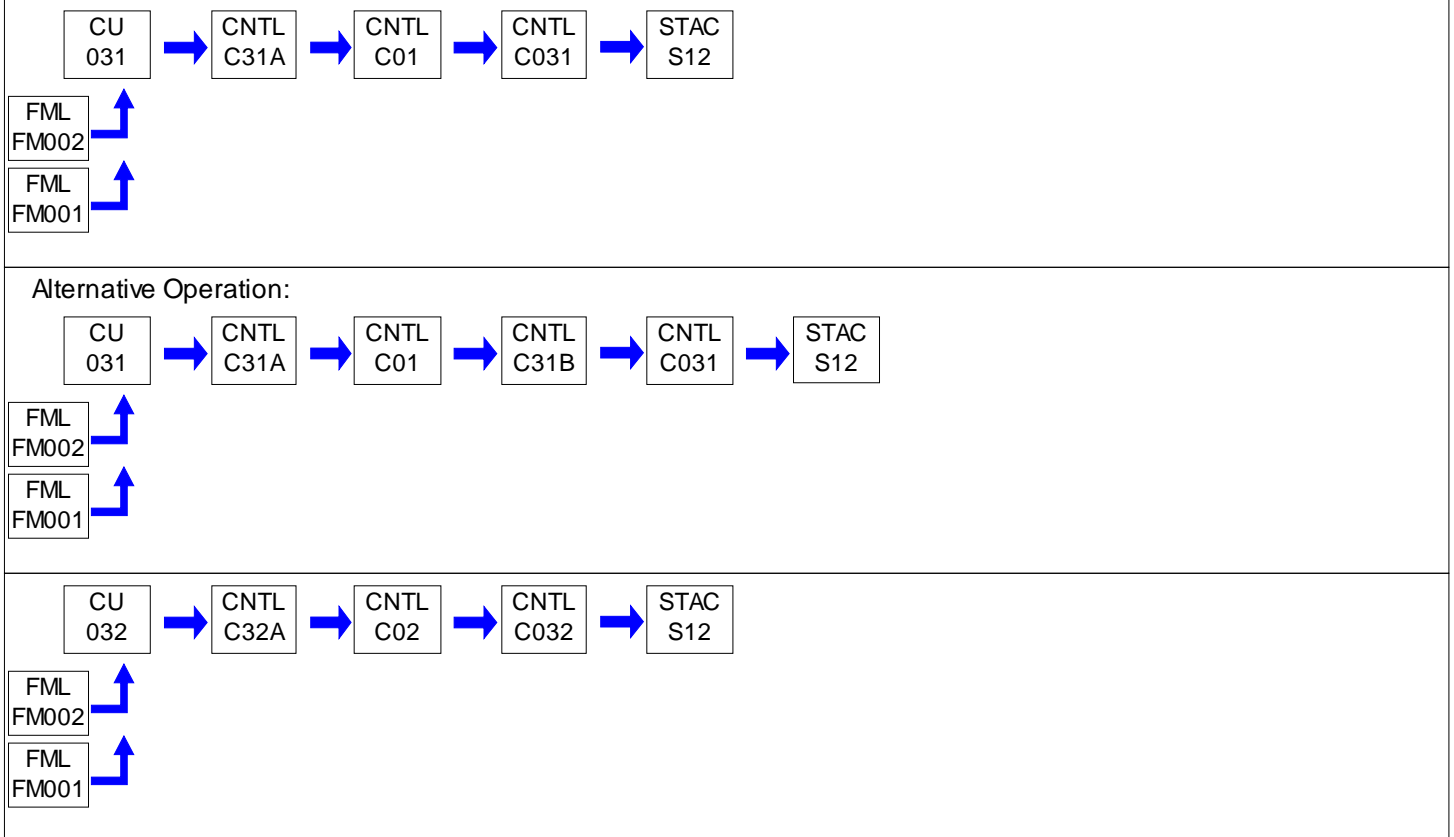

PERMIT MAPS

Alternative Operation:

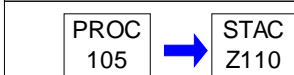
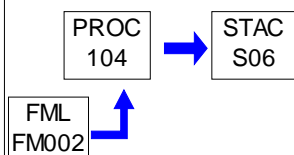
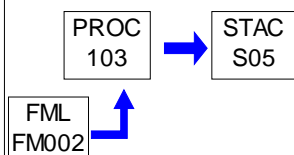
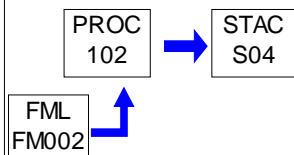
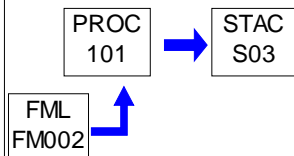
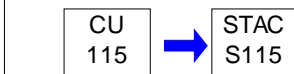
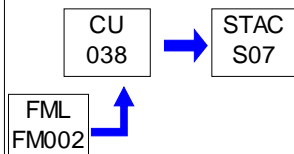
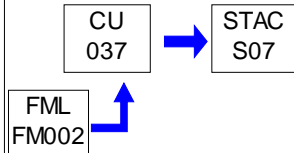
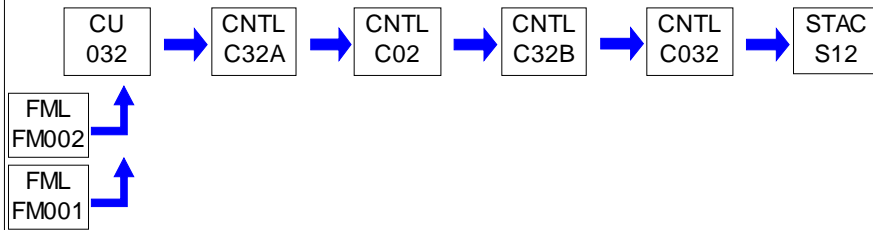

PERMIT MAPS

PROC 106 → STAC Z110

PROC 107 → STAC Z110

PROC 108 → STAC Z108

PROC 109 → STAC Z110

PROC 110 → STAC Z10

PROC 111 → STAC Z111

PROC 112 → STAC Z112

PROC 113 → STAC S113

PROC 114 → STAC S114

PROC 116 → CNTL C116 → STAC S116

**SECTION B. General Title V Requirements****#001 [25 Pa. Code § 121.1]****Definitions**

Words and terms that are not otherwise defined in this permit shall have the meanings set forth in Section 3 of the Air Pollution Control Act (35 P.S. § 4003) and 25 Pa. Code § 121.1.

#002 [25 Pa. Code § 121.7]**Prohibition of Air Pollution**

No person may permit air pollution as that term is defined in the act.

#003 [25 Pa. Code § 127.512(c)(4)]**Property Rights**

This permit does not convey property rights of any sort, or any exclusive privileges.

#004 [25 Pa. Code § 127.446(a) and (c)]**Permit Expiration**

This operating permit is issued for a fixed term of five (5) years and shall expire on the date specified on Page 1 of this permit. The terms and conditions of the expired permit shall automatically continue pending issuance of a new Title V permit, provided the permittee has submitted a timely and complete application and paid applicable fees required under 25 Pa. Code Chapter 127, Subchapter I and the Department is unable, through no fault of the permittee, to issue or deny a new permit before the expiration of the previous permit. An application is complete if it contains sufficient information to begin processing the application, has the applicable sections completed and has been signed by a responsible official.

#005 [25 Pa. Code §§ 127.412, 127.413, 127.414, 127.446(e), 127.503 & 127.704(b)]**Permit Renewal**

(a) An application for the renewal of the Title V permit shall be submitted to the Department at least six (6) months, and not more than 18 months, before the expiration date of this permit. The renewal application is timely if a complete application is submitted to the Department's Regional Air Manager within the timeframe specified in this permit condition.

(b) The application for permit renewal shall include the current permit number, the appropriate permit renewal fee, a description of any permit revisions and off-permit changes that occurred during the permit term, and any applicable requirements that were promulgated and not incorporated into the permit during the permit term. The fees shall be made payable to "The Commonwealth of Pennsylvania Clean Air Fund" and submitted with the fee form to the respective regional office.

(c) The renewal application shall also include submission of proof that the local municipality and county, in which the facility is located, have been notified in accordance with 25 Pa. Code § 127.413. The application for renewal of the Title V permit shall also include submission of compliance review forms which have been used by the permittee to update information submitted in accordance with either 25 Pa. Code § 127.412(b) or § 127.412(j).

(d) The permittee, upon becoming aware that any relevant facts were omitted or incorrect information was submitted in the permit application, shall promptly submit such supplementary facts or corrected information during the permit renewal process. The permittee shall also promptly provide additional information as necessary to address any requirements that become applicable to the source after the date a complete renewal application was submitted but prior to release of a draft permit.

#006 [25 Pa. Code §§ 127.450(a)(4) & 127.464(a)]**Transfer of Ownership or Operational Control**

(a) In accordance with 25 Pa. Code § 127.450(a)(4), a change in ownership or operational control of the source shall be treated as an administrative amendment if:

(1) The Department determines that no other change in the permit is necessary;

(2) A written agreement has been submitted to the Department identifying the specific date of the transfer of permit responsibility, coverage and liability between the current and the new permittee; and,

(3) A compliance review form has been submitted to the Department and the permit transfer has been approved by

SECTION B. General Title V Requirements

the Department.

(b) In accordance with 25 Pa. Code § 127.464(a), this permit may not be transferred to another person except in cases of transfer-of-ownership which are documented and approved to the satisfaction of the Department.

#007 [25 Pa. Code § 127.513, 35 P.S. § 4008 and § 114 of the CAA]**Inspection and Entry**

(a) Upon presentation of credentials and other documents as may be required by law for inspection and entry purposes, the permittee shall allow the Department of Environmental Protection or authorized representatives of the Department to perform the following:

(1) Enter at reasonable times upon the permittee's premises where a Title V source is located or emissions related activity is conducted, or where records are kept under the conditions of this permit;

(2) Have access to and copy or remove, at reasonable times, records that are kept under the conditions of this permit;

(3) Inspect at reasonable times, facilities, equipment including monitoring and air pollution control equipment, practices, or operations regulated or required under this permit;

(4) Sample or monitor, at reasonable times, substances or parameters, for the purpose of assuring compliance with the permit or applicable requirements as authorized by the Clean Air Act, the Air Pollution Control Act, or the regulations promulgated under the Acts.

(b) Pursuant to 35 P.S. § 4008, no person shall hinder, obstruct, prevent or interfere with the Department or its personnel in the performance of any duty authorized under the Air Pollution Control Act.

(c) Nothing in this permit condition shall limit the ability of the EPA to inspect or enter the premises of the permittee in accordance with Section 114 or other applicable provisions of the Clean Air Act.

#008 [25 Pa. Code §§ 127.25, 127.444, & 127.512(c)(1)]**Compliance Requirements**

(a) The permittee shall comply with the conditions of this permit. Noncompliance with this permit constitutes a violation of the Clean Air Act and the Air Pollution Control Act and is grounds for one (1) or more of the following:

(1) Enforcement action

(2) Permit termination, revocation and reissuance or modification

(3) Denial of a permit renewal application

(b) A person may not cause or permit the operation of a source, which is subject to 25 Pa. Code Article III, unless the source(s) and air cleaning devices identified in the application for the plan approval and operating permit and the plan approval issued to the source are operated and maintained in accordance with specifications in the applications and the conditions in the plan approval and operating permit issued by the Department. A person may not cause or permit the operation of an air contamination source subject to 25 Pa. Code Chapter 127 in a manner inconsistent with good operating practices.

(c) For purposes of Sub-condition (b) of this permit condition, the specifications in applications for plan approvals and operating permits are the physical configurations and engineering design details which the Department determines are essential for the permittee's compliance with the applicable requirements in this Title V permit.

#009 [25 Pa. Code § 127.512(c)(2)]**Need to Halt or Reduce Activity Not a Defense**

It shall not be a defense for a permittee in an enforcement action that it would have been necessary to halt or reduce the permitted activity in order to maintain compliance with the conditions of this permit.

**SECTION B. General Title V Requirements****#010 [25 Pa. Code §§ 127.411(d) & 127.512(c)(5)]****Duty to Provide Information**

(a) The permittee shall furnish to the Department, within a reasonable time, information that the Department may request in writing to determine whether cause exists for modifying, revoking and reissuing, or terminating the permit, or to determine compliance with the permit.

(b) Upon request, the permittee shall also furnish to the Department copies of records that the permittee is required to keep by this permit, or for information claimed to be confidential, the permittee may furnish such records directly to the Administrator of EPA along with a claim of confidentiality.

#011 [25 Pa. Code §§ 127.463, 127.512(c)(3) & 127.542]**Reopening and Revising the Title V Permit for Cause**

(a) This Title V permit may be modified, revoked, reopened and reissued or terminated for cause. The filing of a request by the permittee for a permit modification, revocation and reissuance, or termination, or of a notification of planned changes or anticipated noncompliance does not stay a permit condition.

(b) This permit may be reopened, revised and reissued prior to expiration of the permit under one or more of the following circumstances:

(1) Additional applicable requirements under the Clean Air Act or the Air Pollution Control Act become applicable to a Title V facility with a remaining permit term of three (3) or more years prior to the expiration date of this permit. The Department will revise the permit as expeditiously as practicable but not later than 18 months after promulgation of the applicable standards or regulations. No such revision is required if the effective date of the requirement is later than the expiration date of this permit, unless the original permit or its terms and conditions has been extended.

(2) Additional requirements, including excess emissions requirements, become applicable to an affected source under the acid rain program. Upon approval by the Administrator of EPA, excess emissions offset plans for an affected source shall be incorporated into the permit.

(3) The Department or the EPA determines that this permit contains a material mistake or inaccurate statements were made in establishing the emissions standards or other terms or conditions of this permit.

(4) The Department or the Administrator of EPA determines that the permit must be revised or revoked to assure compliance with the applicable requirements.

(c) Proceedings to revise this permit shall follow the same procedures which apply to initial permit issuance and shall affect only those parts of this permit for which cause to revise exists. The revision shall be made as expeditiously as practicable.

(d) Regardless of whether a revision is made in accordance with (b)(1) above, the permittee shall meet the applicable standards or regulations promulgated under the Clean Air Act within the time frame required by standards or regulations.

#012 [25 Pa. Code § 127.543]**Reopening a Title V Permit for Cause by EPA**

As required by the Clean Air Act and regulations adopted thereunder, this permit may be modified, reopened and reissued, revoked or terminated for cause by EPA in accordance with procedures specified in 25 Pa. Code § 127.543.

#013 [25 Pa. Code § 127.522(a)]**Operating Permit Application Review by the EPA**

The applicant may be required by the Department to provide a copy of the permit application, including the compliance plan, directly to the Administrator of the EPA. Copies of title V permit applications to EPA, pursuant to 25 PA Code §127.522(a), shall be submitted, if required, to the following EPA e-mail box:

R3_Air_Apps_and_Notices@epa.gov

Please place the following in the subject line: TV [permit number], [Facility Name].

**SECTION B. General Title V Requirements****#014 [25 Pa. Code § 127.541]****Significant Operating Permit Modifications**

When permit modifications during the term of this permit do not qualify as minor permit modifications or administrative amendments, the permittee shall submit an application for significant Title V permit modifications in accordance with 25 Pa. Code § 127.541. Notifications to EPA, pursuant to 25 PA Code §127.522(a), if required, shall be submitted, to the following EPA e-mail box:

R3_Air_Apps_and_Notices@epa.gov

Please place the following in the subject line: TV [permit number], [Facility Name].

#015 [25 Pa. Code §§ 121.1 & 127.462]**Minor Operating Permit Modifications**

The permittee may make minor operating permit modifications (as defined in 25 Pa. Code §121.1), on an expedited basis, in accordance with 25 Pa. Code §127.462 (relating to minor operating permit modifications). Notifications to EPA, pursuant to 25 PA Code §127.462(c), if required, shall be submitted, to the following EPA e-mail box:

R3_Air_Apps_and_Notices@epa.gov

Please place the following in the subject line: TV [permit number], [Facility Name].

#016 [25 Pa. Code § 127.450]**Administrative Operating Permit Amendments**

(a) The permittee may request administrative operating permit amendments, as defined in 25 Pa. Code §127.450(a). Copies of request for administrative permit amendment to EPA, pursuant to 25 PA Code §127.450(c)(1), if required, shall be submitted to the following EPA e-mail box:

R3_Air_Apps_and_Notices@epa.gov

Please place the following in the subject line: TV [permit number], [Facility Name].

(b) Upon final action by the Department granting a request for an administrative operating permit amendment covered under §127.450(a)(5), the permit shield provisions in 25 Pa. Code § 127.516 (relating to permit shield) shall apply to administrative permit amendments incorporated in this Title V Permit in accordance with §127.450(c), unless precluded by the Clean Air Act or the regulations thereunder.

#017 [25 Pa. Code § 127.512(b)]**Severability Clause**

The provisions of this permit are severable, and if any provision of this permit is determined by the Environmental Hearing Board or a court of competent jurisdiction, or US EPA to be invalid or unenforceable, such a determination will not affect the remaining provisions of this permit.

#018 [25 Pa. Code §§ 127.704, 127.705 & 127.707]**Fee Payment**

(a) The permittee shall pay fees to the Department in accordance with the applicable fee schedules in 25 Pa. Code Chapter 127, Subchapter I (relating to plan approval and operating permit fees). The applicable fees shall be made payable to "The Commonwealth of Pennsylvania Clean Air Fund" with the permit number clearly indicated and submitted to the respective regional office.

(b) Emission Fees. The permittee shall, on or before September 1st of each year, pay applicable annual Title V emission fees for emissions occurring in the previous calendar year as specified in 25 Pa. Code § 127.705. The permittee is not required to pay an emission fee for emissions of more than 4,000 tons of each regulated pollutant emitted from the facility.

(c) As used in this permit condition, the term "regulated pollutant" is defined as a VOC, each pollutant regulated under Sections 111 and 112 of the Clean Air Act and each pollutant for which a National Ambient Air Quality Standard has been promulgated, except that carbon monoxide is excluded.

**SECTION B. General Title V Requirements**

(d) Late Payment. Late payment of emission fees will subject the permittee to the penalties prescribed in 25 Pa. Code § 127.707 and may result in the suspension or termination of the Title V permit. The permittee shall pay a penalty of fifty percent (50%) of the fee amount, plus interest on the fee amount computed in accordance with 26 U.S.C.A. § 6621(a)(2) from the date the emission fee should have been paid in accordance with the time frame specified in 25 Pa. Code § 127.705(c).

(e) The permittee shall pay an annual operating permit maintenance fee according to the following fee schedule established in 25 Pa. Code § 127.704(d) on or before December 31 of each year for the next calendar year.

(1) Eight thousand dollars (\$8,000) for calendar years 2021—2025.

(2) Ten thousand dollars (\$10,000) for calendar years 2026—2030.

(3) Twelve thousand five hundred dollars (\$12,500) for the calendar years beginning with 2031.

#019 [25 Pa. Code §§ 127.14(b) & 127.449]**Authorization for De Minimis Emission Increases**

(a) This permit authorizes de minimis emission increases from a new or existing source in accordance with 25 Pa. Code §§ 127.14 and 127.449 without the need for a plan approval or prior issuance of a permit modification. The permittee shall provide the Department with seven (7) days prior written notice before commencing any de minimis emissions increase that would result from either: (1) a physical change of minor significance under § 127.14(c)(1); or (2) the construction, installation, modification or reactivation of an air contamination source. The written notice shall:

(1) Identify and describe the pollutants that will be emitted as a result of the de minimis emissions increase.

(2) Provide emission rates expressed in tons per year and in terms necessary to establish compliance consistent with any applicable requirement.

The Department may disapprove or condition de minimis emission increases at any time.

(b) Except as provided below in (c) and (d) of this permit condition, the permittee is authorized during the term of this permit to make de minimis emission increases (expressed in tons per year) up to the following amounts without the need for a plan approval or prior issuance of a permit modification:

(1) Four tons of carbon monoxide from a single source during the term of the permit and 20 tons of carbon monoxide at the facility during the term of the permit.

(2) One ton of NO_x from a single source during the term of the permit and 5 tons of NO_x at the facility during the term of the permit.

(3) One and six-tenths tons of the oxides of sulfur from a single source during the term of the permit and 8.0 tons of oxides of sulfur at the facility during the term of the permit.

(4) Six-tenths of a ton of PM₁₀ from a single source during the term of the permit and 3.0 tons of PM₁₀ at the facility during the term of the permit. This shall include emissions of a pollutant regulated under Section 112 of the Clean Air Act unless precluded by the Clean Air Act or 25 Pa. Code Article III.

(5) One ton of VOCs from a single source during the term of the permit and 5.0 tons of VOCs at the facility during the term of the permit. This shall include emissions of a pollutant regulated under Section 112 of the Clean Air Act unless precluded by the Clean Air Act or 25 Pa. Code Article III.

(c) In accordance with § 127.14, the permittee may install the following minor sources without the need for a plan approval:

(1) Air conditioning or ventilation systems not designed to remove pollutants generated or released from other sources.

(2) Combustion units rated at 2,500,000 or less Btu per hour of heat input.

**SECTION B. General Title V Requirements**

(3) Combustion units with a rated capacity of less than 10,000,000 Btu per hour heat input fueled by natural gas supplied by a public utility, liquefied petroleum gas or by commercial fuel oils which are No. 2 or lighter, viscosity less than or equal to 5.82 c St, and which meet the sulfur content requirements of 25 Pa. Code § 123.22 (relating to combustion units). For purposes of this permit, commercial fuel oil shall be virgin oil which has no reprocessed, recycled or waste material added.

(4) Space heaters which heat by direct heat transfer.

(5) Laboratory equipment used exclusively for chemical or physical analysis.

(6) Other sources and classes of sources determined to be of minor significance by the Department.

(d) This permit does not authorize de minimis emission increases if the emissions increase would cause one or more of the following:

(1) Increase the emissions of a pollutant regulated under Section 112 of the Clean Air Act except as authorized in Subparagraphs (b)(4) and (5) of this permit condition.

(2) Subject the facility to the prevention of significant deterioration requirements in 25 Pa. Code Chapter 127, Subchapter D and/or the new source review requirements in Subchapter E.

(3) Violate any applicable requirement of the Air Pollution Control Act, the Clean Air Act, or the regulations promulgated under either of the acts.

(4) Changes which are modifications under any provision of Title I of the Clean Air Act and emission increases which would exceed the allowable emissions level (expressed as a rate of emissions or in terms of total emissions) under the Title V permit.

(e) Unless precluded by the Clean Air Act or the regulations thereunder, the permit shield described in 25 Pa. Code § 127.516 (relating to permit shield) shall extend to the changes made under 25 Pa. Code § 127.449 (relating to de minimis emission increases).

(f) Emissions authorized under this permit condition shall be included in the monitoring, recordkeeping and reporting requirements of this permit.

(g) Except for de minimis emission increases allowed under this permit, 25 Pa. Code § 127.449, or sources and physical changes meeting the requirements of 25 Pa. Code § 127.14, the permittee is prohibited from making physical changes or engaging in activities that are not specifically authorized under this permit without first applying for a plan approval. In accordance with § 127.14(b), a plan approval is not required for the construction, modification, reactivation, or installation of the sources creating the de minimis emissions increase.

(h) The permittee may not meet de minimis emission threshold levels by offsetting emission increases or decreases at the same source.

#020 [25 Pa. Code §§ 127.11a & 127.215]**Reactivation of Sources**

(a) The permittee may reactivate a source at the facility that has been out of operation or production for at least one year, but less than or equal to five (5) years, if the source is reactivated in accordance with the requirements of 25 Pa. Code §§ 127.11a and 127.215. The reactivated source will not be considered a new source.

(b) A source which has been out of operation or production for more than five (5) years but less than 10 years may be reactivated and will not be considered a new source if the permittee satisfies the conditions specified in 25 Pa. Code § 127.11a(b).

#021 [25 Pa. Code §§ 121.9 & 127.216]**Circumvention**

(a) The owner of this Title V facility, or any other person, may not circumvent the new source review requirements of 25 Pa. Code Chapter 127, Subchapter E by causing or allowing a pattern of ownership or development, including the

**SECTION B. General Title V Requirements**

phasing, staging, delaying or engaging in incremental construction, over a geographic area of a facility which, except for the pattern of ownership or development, would otherwise require a permit or submission of a plan approval application.

(b) No person may permit the use of a device, stack height which exceeds good engineering practice stack height, dispersion technique or other technique which, without resulting in reduction of the total amount of air contaminants emitted, conceals or dilutes an emission of air contaminants which would otherwise be in violation of this permit, the Air Pollution Control Act or the regulations promulgated thereunder, except that with prior approval of the Department, the device or technique may be used for control of malodors.

#022 [25 Pa. Code §§ 127.402(d) & 127.513(1)]**Submissions**

(a) Reports, test data, monitoring data, notifications and requests for renewal of the permit shall be submitted to the:

Regional Air Program Manager
PA Department of Environmental Protection
(At the address given on the permit transmittal letter, or otherwise notified)

(b) Any report or notification for the EPA Administrator or EPA Region III should be addressed to:

Enforcement & Compliance Assurance Division
Air, RCRA and Toxics Branch
Air Section
1650 Arch Street, 3ED21
Philadelphia, PA 19103

The Title V compliance certification shall be emailed to EPA at R3_APD_Permits@epa.gov.

(c) An application, form, report or compliance certification submitted pursuant to this permit condition shall contain certification by a responsible official as to truth, accuracy, and completeness as required under 25 Pa. Code § 127.402(d). Unless otherwise required by the Clean Air Act or regulations adopted thereunder, this certification and any other certification required pursuant to this permit shall state that, based on information and belief formed after reasonable inquiry, the statements and information in the document are true, accurate and complete.

#023 [25 Pa. Code §§ 127.441(c) & 127.463(e); Chapter 139; & 114(a)(3), 504(b) of the CAA]**Sampling, Testing and Monitoring Procedures**

(a) The permittee shall perform the emissions monitoring and analysis procedures or test methods for applicable requirements of this Title V permit. In addition to the sampling, testing and monitoring procedures specified in this permit, the Permittee shall comply with any additional applicable requirements promulgated under the Clean Air Act after permit issuance regardless of whether the permit is revised.

(b) The sampling, testing and monitoring required under the applicable requirements of this permit, shall be conducted in accordance with the requirements of 25 Pa. Code Chapter 139 unless alternative methodology is required by the Clean Air Act (including §§ 114(a)(3) and 504(b)) and regulations adopted thereunder.

#024 [25 Pa. Code § 127.513]**Compliance Certification**

(a) One year after the date of issuance of the Title V permit, and each year thereafter, unless specified elsewhere in the permit, the permittee shall submit to the Department and EPA Region III a certificate of compliance with the terms and conditions in this permit, for the previous year, including the emission limitations, standards or work practices. This certification shall include:

- (1) The identification of each term or condition of the permit that is the basis of the certification.
- (2) The compliance status.
- (3) The methods used for determining the compliance status of the source, currently and over the reporting period.
- (4) Whether compliance was continuous or intermittent.

(b) The compliance certification shall be postmarked or hand-delivered no later than thirty days after each anniversary of

**SECTION B. General Title V Requirements**

the date of issuance of this Title V Operating Permit, or on the submittal date specified elsewhere in the permit, to the Department in accordance with the submission requirements specified in Section B, Condition #022 of this permit. The Title V compliance certification shall be emailed to EPA at R3_APD_Permits@epa.gov.

#025 [25 Pa. Code §§ 127.511 & Chapter 135]**Recordkeeping Requirements**

(a) The permittee shall maintain and make available, upon request by the Department, records of required monitoring information that include the following:

- (1) The date, place (as defined in the permit) and time of sampling or measurements.
- (2) The dates the analyses were performed.
- (3) The company or entity that performed the analyses.
- (4) The analytical techniques or methods used.
- (5) The results of the analyses.
- (6) The operating conditions as existing at the time of sampling or measurement.

(b) The permittee shall retain records of the required monitoring data and supporting information for at least five (5) years from the date of the monitoring sample, measurement, report or application. Supporting information includes the calibration data and maintenance records and original strip-chart recordings for continuous monitoring instrumentation, and copies of reports required by the permit.

(c) The permittee shall maintain and make available to the Department upon request, records including computerized records that may be necessary to comply with the reporting, recordkeeping and emission statement requirements in 25 Pa. Code Chapter 135 (relating to reporting of sources). In accordance with 25 Pa. Code Chapter 135, § 135.5, such records may include records of production, fuel usage, maintenance of production or pollution control equipment or other information determined by the Department to be necessary for identification and quantification of potential and actual air contaminant emissions. If direct recordkeeping is not possible or practical, sufficient records shall be kept to provide the needed information by indirect means.

#026 [25 Pa. Code §§ 127.411(d), 127.442, 127.463(e) & 127.511(c)]**Reporting Requirements**

(a) The permittee shall comply with the reporting requirements for the applicable requirements specified in this Title V permit. In addition to the reporting requirements specified herein, the permittee shall comply with any additional applicable reporting requirements promulgated under the Clean Air Act after permit issuance regardless of whether the permit is revised.

(b) Pursuant to 25 Pa. Code § 127.511(c), the permittee shall submit reports of required monitoring at least every six (6) months unless otherwise specified in this permit. Instances of deviations (as defined in 25 Pa. Code § 121.1) from permit requirements shall be clearly identified in the reports. The reporting of deviations shall include the probable cause of the deviations and corrective actions or preventative measures taken, except that sources with continuous emission monitoring systems shall report according to the protocol established and approved by the Department for the source. The required reports shall be certified by a responsible official.

(c) Every report submitted to the Department under this permit condition shall comply with the submission procedures specified in Section B, Condition #022(c) of this permit.

(d) Any records, reports or information obtained by the Department or referred to in a public hearing shall be made available to the public by the Department except for such records, reports or information for which the permittee has shown cause that the documents should be considered confidential and protected from disclosure to the public under Section 4013.2 of the Air Pollution Control Act and consistent with Sections 112(d) and 114(c) of the Clean Air Act and 25 Pa. Code § 127.411(d). The permittee may not request a claim of confidentiality for any emissions data generated for the Title V facility.

**SECTION B. General Title V Requirements****#027 [25 Pa. Code § 127.3]****Operational Flexibility**

The permittee is authorized to make changes within the Title V facility in accordance with the following provisions in 25 Pa. Code Chapter 127 which implement the operational flexibility requirements of Section 502(b)(10) of the Clean Air Act and Section 6.1(i) of the Air Pollution Control Act:

- (1) Section 127.14 (relating to exemptions)
- (2) Section 127.447 (relating to alternative operating scenarios)
- (3) Section 127.448 (relating to emissions trading at facilities with federally enforceable emissions caps)
- (4) Section 127.449 (relating to de minimis emission increases)
- (5) Section 127.450 (relating to administrative operating permit amendments)
- (6) Section 127.462 (relating to minor operating permit amendments)
- (7) Subchapter H (relating to general plan approvals and operating permits)

#028 [25 Pa. Code §§ 127.441(d), 127.512(i) and 40 CFR Part 68]**Risk Management**

(a) If required by Section 112(r) of the Clean Air Act, the permittee shall develop and implement an accidental release program consistent with requirements of the Clean Air Act, 40 CFR Part 68 (relating to chemical accident prevention provisions) and the Federal Chemical Safety Information, Site Security and Fuels Regulatory Relief Act (P.L. 106-40).

(b) The permittee shall prepare and implement a Risk Management Plan (RMP) which meets the requirements of Section 112(r) of the Clean Air Act, 40 CFR Part 68 and the Federal Chemical Safety Information, Site Security and Fuels Regulatory Relief Act when a regulated substance listed in 40 CFR § 68.130 is present in a process in more than the listed threshold quantity at the Title V facility. The permittee shall submit the RMP to the federal Environmental Protection Agency according to the following schedule and requirements:

- (1) The permittee shall submit the first RMP to a central point specified by EPA no later than the latest of the following:
 - (i) Three years after the date on which a regulated substance is first listed under § 68.130; or,
 - (ii) The date on which a regulated substance is first present above a threshold quantity in a process.

(2) The permittee shall submit any additional relevant information requested by the Department or EPA concerning the RMP and shall make subsequent submissions of RMPs in accordance with 40 CFR § 68.190.

(3) The permittee shall certify that the RMP is accurate and complete in accordance with the requirements of 40 CFR Part 68, including a checklist addressing the required elements of a complete RMP.

(c) As used in this permit condition, the term "process" shall be as defined in 40 CFR § 68.3. The term "process" means any activity involving a regulated substance including any use, storage, manufacturing, handling, or on-site movement of such substances or any combination of these activities. For purposes of this definition, any group of vessels that are interconnected, or separate vessels that are located such that a regulated substance could be involved in a potential release, shall be considered a single process.

(d) If the Title V facility is subject to 40 CFR Part 68, as part of the certification required under this permit, the permittee shall:

- (1) Submit a compliance schedule for satisfying the requirements of 40 CFR Part 68 by the date specified in 40 CFR § 68.10(a); or,
- (2) Certify that the Title V facility is in compliance with all requirements of 40 CFR Part 68 including the registration and submission of the RMP.

**SECTION B. General Title V Requirements**

(e) If the Title V facility is subject to 40 CFR Part 68, the permittee shall maintain records supporting the implementation of an accidental release program for five (5) years in accordance with 40 CFR § 68.200.

(f) When the Title V facility is subject to the accidental release program requirements of Section 112(r) of the Clean Air Act and 40 CFR Part 68, appropriate enforcement action will be taken by the Department if:

(1) The permittee fails to register and submit the RMP or a revised plan pursuant to 40 CFR Part 68.

(2) The permittee fails to submit a compliance schedule or include a statement in the compliance certification required under Section B, Condition #026 of this permit that the Title V facility is in compliance with the requirements of Section 112(r) of the Clean Air Act, 40 CFR Part 68, and 25 Pa. Code § 127.512(i).

#029 [25 Pa. Code § 127.512(e)]**Approved Economic Incentives and Emission Trading Programs**

No permit revision shall be required under approved economic incentives, marketable permits, emissions trading and other similar programs or processes for changes that are provided for in this Title V permit.

#030 [25 Pa. Code §§ 127.516, 127.450(d), 127.449(f) & 127.462(g)]**Permit Shield**

(a) The permittee's compliance with the conditions of this permit shall be deemed in compliance with applicable requirements (as defined in 25 Pa. Code § 121.1) as of the date of permit issuance if either of the following applies:

(1) The applicable requirements are included and are specifically identified in this permit.

(2) The Department specifically identifies in the permit other requirements that are not applicable to the permitted facility or source.

(b) Nothing in 25 Pa. Code § 127.516 or the Title V permit shall alter or affect the following:

(1) The provisions of Section 303 of the Clean Air Act, including the authority of the Administrator of the EPA provided thereunder.

(2) The liability of the permittee for a violation of an applicable requirement prior to the time of permit issuance.

(3) The applicable requirements of the acid rain program, consistent with Section 408(a) of the Clean Air Act.

(4) The ability of the EPA to obtain information from the permittee under Section 114 of the Clean Air Act.

(c) Unless precluded by the Clean Air Act or regulations thereunder, final action by the Department incorporating a significant permit modification in this Title V Permit shall be covered by the permit shield at the time that the permit containing the significant modification is issued.

#031 [25 Pa. Code §135.3]**Reporting**

(a) The permittee shall submit by March 1 of each year an annual emissions report for the preceding calendar year. The report shall include information for all active previously reported sources, new sources which were first operated during the preceding calendar year, and sources modified during the same period which were not previously reported. All air emissions from the facility should be estimated and reported.

(b) A source owner or operator may request an extension of time from the Department for the filing of an annual emissions report, and the Department may grant the extension for reasonable cause.

#032 [25 Pa. Code §135.4]**Report Format**

Emissions reports shall contain sufficient information to enable the Department to complete its emission inventory. Emissions reports shall be made by the source owner or operator in a format specified by the Department.

**SECTION C. Site Level Requirements****I. RESTRICTIONS.****Emission Restriction(s).****# 001 [25 Pa. Code §123.1]****Prohibition of certain fugitive emissions**

(a) No person may permit the emission into the outdoor atmosphere of fugitive air contaminant from a source other than the following:

(1) Construction or demolition of buildings or structures.

(2) Grading, paving and maintenance of roads and streets.

(3) Use of roads and streets. Emissions from material in or on trucks, railroad cars and other vehicular equipment are not considered as emissions from use of roads and streets.

(4) Clearing of land.

(5) Stockpiling of materials.

(6) Open burning operations.

(7) N/A

(8) N/A

(9) Sources and classes of sources other than those identified in paragraphs (1)-(8), for which the operator has obtained a determination from the Department that fugitive emissions from the source, after appropriate control, meet the following requirements:

(i) the emissions are of minor significance with respect to causing air pollution; and

(ii) the emissions are not preventing or interfering with the attainment or maintenance of any ambient air quality standard.

(b) An application form for requesting a determination under either subsection (a)(9) or 129.15(c) is available from the Department. In reviewing these applications, the Department may require the applicant to supply information including, but not limited to, a description of proposed control measures, characteristics of emissions, quantity of emissions, and ambient air quality data and analysis showing the impact of the source on ambient air quality. The applicant shall be required to demonstrate that the requirements of subsections (a)(9) and (c) and 123.2 (relating to fugitive particulate matter) or of the requirements of 129.15(c) have been satisfied. Upon such demonstration, the Department will issue a determination, in writing, either as an operating permit condition, for those sources subject to permit requirements under the act, or as an order containing appropriate conditions and limitations.

(c) A person responsible for any source specified in subsections (a)(1) -- (7) or (9) shall take all reasonable actions to prevent particulate matter from becoming airborne. These actions shall include, but not be limited to, the following:

(1) Use, where possible, of water or chemicals for control of dust in the demolition of buildings or structures, construction operations, the grading of roads, or the clearing of land.

(2) Application of asphalt, oil, water or suitable chemicals on dirt roads, material stockpiles and other surfaces which may give rise to airborne dusts.

(3) Paving and maintenance of roadways.

(4) Prompt removal of earth or other material from paved streets onto which earth or other material has been transported by trucking or earth moving equipment, erosion by water, or other means.

(d) N/A.

**SECTION C. Site Level Requirements****# 002 [25 Pa. Code §123.2]****Fugitive particulate matter**

A person may not permit fugitive particulate matter to be emitted into the outdoor atmosphere from a source specified in §123.1(a)(1) -- (9) (relating to prohibition of certain fugitive emissions) if such emissions are visible at the point the emissions pass outside the person's property.

003 [25 Pa. Code §123.31]**Limitations**

A person may not permit the emission into the outdoor atmosphere of any malodorous air contaminants from any source, in such a manner that the malodors are detectable outside the property of the person on whose land the source is being operated.

004 [25 Pa. Code §123.41]**Limitations**

A person may not permit the emission into the outdoor atmosphere of visible air contaminants in such a manner that the opacity of the emission is either of the following:

- (1) Equal to or greater than 20% for a period or periods aggregating more than three minutes in any 1 hour.
- (2) Equal to or greater than 60% at any time.

If the opacity limitations given by § 123.41 conflict with any other opacity limitation in this permit, the more stringent limitation applies.

005 [25 Pa. Code §129.14]**Open burning operations**

(a) In air basins. – Not Applicable

(b) Outside of air basins. No person may permit the open burning of material in an area outside of air basins in a manner that:

(1) The emissions are visible, at any time, at the point such emissions pass outside the property of the person on whose land the open burning is being conducted.

(2) Malodorous air contaminants from the open burning are detectable outside the property of the person on whose land the open burning is being conducted.

(3) The emissions interfere with the reasonable enjoyment of life or property.

(4) The emissions cause damage to vegetation or property.

(5) The emissions are or may be deleterious to human or animal health

(c) Exceptions: The requirements of subsections (a) and (b) do not apply where the open burning operations result from:

(1) A fire set to prevent or abate a fire hazard, when approved by the Department and set by or under the supervision of a public officer.

(2) A fire set for the purpose of instructing personnel in fire fighting, when approved by the Department.

(3) A fire set for the prevention and control of disease or pests, when approved by the Department.

(4) Not applicable.

(5) Not applicable.

(6) A fire set solely for recreational or ceremonial purposes.



SECTION C. Site Level Requirements

(7) A fire set solely for cooking food.

(d) Clearing and grubbing wastes. The following is applicable to clearing and grubbing wastes:

(1) As used in this subsection the following terms shall have the following meanings:

Air curtain destructor -- A mechanical device which forcefully projects a curtain of air across a pit in which open burning is being conducted so that combustion efficiency is increased and smoke and other particulate matter are contained.

Clearing and grubbing wastes -- Trees, shrubs, and other native vegetation which are cleared from land during or prior to the process of construction. The term does not include demolition wastes and dirt laden roots.

(2) Not applicable.

(3) Subsection (b) notwithstanding clearing and grubbing wastes may be burned outside of an air basin, subject to the following limitations:

(i) Upon receipt of a complaint or determination by the Department that an air pollution problem exists, the Department may order that the open burning cease or comply with subsection (b).

(ii) Authorization for open burning under this paragraph does not apply to clearing and grubbing wastes transported from an air basin for disposal outside of an air basin.

(4) During an air pollution episode, open burning is limited by Chapter 137 (relating to air pollution episodes) and shall cease as specified in such chapter.

[The Keystone Station is not located in an air basin.]

[This permit does not constitute authorization to burn solid waste pursuant to Section 610(3) of the Solid Waste Management Act, 35 P.S. Section 6018.610(3), or any other provision of the Solid Waste Management Act.]

Fuel Restriction(s).

006 [25 Pa. Code §123.22]

Combustion units

(a) Nonair basin areas. Combustion units in nonair basin areas must conform with the following:

(1) N/A.

(2) Commercial fuel oil.

(i) Except as specified in subparagraphs (ii) and (iii), a person may not offer for sale, deliver for use, exchange in trade or permit the use of commercial fuel oil in nonair basin areas if the commercial fuel oil contains sulfur in excess of the applicable maximum allowable sulfur content set forth in the following tables:

(First Table) Grades Commercial Fuel Oil Maximum Allowable % Sulfur by Weight through June 30, 2016

No. 2 and Lighter (viscosity less than or equal to 5.820cSt) - 0.5

(Second Table) Maximum Allowable Sulfur Content Beginning July 1, 2016, Expressed as Parts per Million (ppm) by Weight or Percentage by Weight

Grades Commercial Fuel Oil (Consistent with ASTM D396)

SECTION C. Site Level Requirements

No. 2 and lighter oil - 500 ppm (0.05%)

(ii) Commercial fuel oil that was stored in this Commonwealth by the ultimate consumer prior to July 1, 2016, which met the applicable maximum allowable sulfur content for commercial fuel oil through June 30, 2016, in subparagraph (i) at the time it was stored, may be used by the ultimate consumer in this Commonwealth on and after July 1, 2016.

(iii) N/A.

(iv) The Department will limit a suspension or increase in the applicable maximum allowable sulfur content granted under subparagraph (iii) to the shortest duration in which adequate supplies of compliant commercial fuel oil can be made reasonably available, but in no case longer than 60 days from the date the Department grants the suspension or increase.

(3) - (4) N/A.

(b) - (h) N/A.

[The Keystone Station does not combust fuel oil heavier than No. 2.]

II. TESTING REQUIREMENTS.**# 007 [25 Pa. Code §127.441]****Operating permit terms and conditions.**

If, at any time, the Department has cause to believe that air contaminant emissions from the facility covered by this operating permit are in excess of the limitations specified in, or established pursuant to, any applicable regulation, the Department shall require the permittee to conduct tests deemed necessary to demonstrate compliance. The permittee shall perform such testing in accordance with the applicable provisions of 25 Pa. Code Chapter 139 (relating to sampling and testing) and in accordance with any restrictions or limitations established by the Department at the time the permittee is notified in writing, of the testing requirement.

008 [25 Pa. Code §139.1]**Sampling facilities.**

Upon the request of the Department, the person responsible for a source shall provide adequate sampling ports, safe sampling platforms and adequate utilities for the performance by the Department of tests on such source. The Department will set forth, in the request, the time period in which the facilities shall be provided as well as the specifications for such facilities.

III. MONITORING REQUIREMENTS.**# 009 [25 Pa. Code §127.441]****Operating permit terms and conditions.**

[Additional authority for this permit condition is derived from 25 Pa. Code Section 127.511]

(a) The permittee shall conduct a daily inspection during daylight hours of sources covered by this permit that are operating at the facility to determine:

- (1) the presence of visible stack emissions.
- (2) the presence of visible fugitive emissions.
- (3) the presence of malodors beyond the boundaries of the facility.

(b) All detected visible stack emissions, visible fugitive emissions or malodors that have the potential to exceed applicable limits shall be reported to the manager of the facility.

(c) Should visible stack emissions in excess of permit limits persist for more than 24-hours (or 48-hours on weekends or holidays) and the condition is not abated, a trained observer shall conduct Method 9 observations for at least 1 hour during each 6-hour daylight period until the condition is abated.

**SECTION C. Site Level Requirements****IV. RECORDKEEPING REQUIREMENTS.****# 010 [25 Pa. Code §127.441]****Operating permit terms and conditions.**

At a minimum, all records and necessary calculations shall be retained for a minimum of at least five (5) years. These records and calculations shall be made available to the Department upon request.

011 [25 Pa. Code §127.441]**Operating permit terms and conditions.**

[Additional authority for this permit condition is derived from 25 Pa. Code Section 127.511]

(a) The permittee shall keep records of the daily facility inspections. Records shall include the name of the person conducting the inspections, the date and time of the inspection, and the results of each inspection. If instances of unpermitted visible stack emissions, visible fugitive emissions or malodorous air emissions are observed, records shall be kept of the corrective action taken to abate same and/or to prevent future occurrences.

(b) These records shall be maintained in a logbook, or equivalent recordkeeping approach.

012 [25 Pa. Code §127.442]**Reporting requirements.**

(a) The owner or operator shall report each malfunction that occurs at this facility that poses an imminent and substantial danger to the public health and safety or the environment or which it should reasonably believe may result in citizen complaints to the Department. For purpose of this condition a malfunction is defined as any sudden, infrequent, and not reasonably preventable failure of air pollution control equipment or source to operate in a normal or usual manner that may result in an increase in the emission of air contaminants. Examples of malfunctions that may result in citizen complaints include but are not limited to: large dust plumes, heavy smoke, a spill or release that results in a malodor that is detectable outside the property of the person on whose land the source is being operated.

(b) When the malfunction poses an imminent and substantial danger to the public health and safety or the environment, the notification shall be submitted to the Department no later than one hour after the incident. All other malfunctions that must be reported under subsection (a) shall be reported to the Department no later than the next business day.

(c) The report shall describe the:

- (i) name and location of the facility;
- (ii) nature and cause of the malfunction;
- (iii) time when the malfunction was first observed;
- (iv) expected duration of excess emissions; and
- (v) estimated rate of emissions.

(d) The owner or operator shall notify the Department immediately when corrective measures have been accomplished.

(e) Subsequent to the malfunction, the owner/operator shall submit a full written report to the Department including the items identified in (c) and corrective measures taken on the malfunction within 15 days, if requested.

(f) Malfunctions shall be reported to the Department at the following address:

PADEP
Office of Air Quality
230 Chestnut Street
Meadville, PA 16335
814-332-6945

013 [25 Pa. Code §127.511]**Monitoring and related recordkeeping and reporting requirements.**

The Owner/Operator shall maintain monthly records of operating hours and fuel consumption for each source at this facility. Records shall include coal, fuel oil, ammonia use by each SCR, and limestone consumption. These records shall be used to calculate emissions for the sources at the facility and shall be used to determine compliance with emission

**SECTION C. Site Level Requirements**

limitations as appropriate.

In addition, as established in RACT Operating Permit 03-000-027 and in accordance with 25 Pa Code §129.95, the permittee shall keep sufficient records to demonstrate compliance with the limitations, restrictions and requirements of the RACT Operating Permit. These records shall provide sufficient data and calculations to clearly demonstrate compliance with all averaging times and periods.

014 [25 Pa. Code §135.5]**Recordkeeping**

Source owners or operators shall maintain and make available upon request by the Department records including computerized records that may be necessary to comply with 135.21 (relating to reporting; and emission statements). These may include records of production, fuel usage, maintenance of production or pollution control equipment or other information determined by the Department to be necessary for identification and quantification of potential and actual air contaminant emissions. If direct recordkeeping is not possible or practical, sufficient records shall be kept to provide the needed information by indirect means.

V. REPORTING REQUIREMENTS.**# 015 [25 Pa. Code §127.442]****Reporting requirements.**

The owner/operator shall submit reports on the operation and maintenance of the source to the Regional Air Program Manager at such intervals and in such form and detail as may be required by the Department. Information required in the reports may include, but is not limited to, process weight rates, firing rates, hours of operation, and maintenance schedules.

016 [25 Pa. Code §127.511]**Monitoring and related recordkeeping and reporting requirements.**

Owner/operator shall submit the semi-annual monitoring reports for this facility by January 30 and July 30 of each year. The January 30 semi-annual monitoring report shall cover the period from July 1 through December 31. The July 30 semiannual monitoring report shall cover the period from January 1 through June 30. However, in accordance with Title 25 PA Code § 127.511(c), in no case shall the semi-annual monitoring report be submitted less often than every six (6) months. This may require that an interim semi-annual monitoring report (covering a period less than six (6) months) be submitted to bring the facility into compliance with this schedule.

[Pursuant to Section B, Condition #025]

017 [25 Pa. Code §127.513]**Compliance certification.**

Permittee shall submit a Compliance Certification sufficient to demonstrate compliance with terms and conditions contained in the permit. Each Compliance Certification shall include the following:

- (a) The identification of each term or condition of the permit that is the basis of the certification.
- (b) The compliance status.
- (c) The methods used for determining the compliance status of the source, currently and over the reporting period.
- (d) Whether compliance was continuous or intermittent.
- (e) Other facts the Department may require to determine the compliance status of the source.

Owner/operator shall submit a Title V Compliance Certification for this facility by January 30 of each year. The Title V Compliance Certification shall cover the previous calendar year, for the period January 1 through December 31. This Certification shall be submitted to both the Director, Air, Toxics, and Radiation of EPA, Region III and the Regional Air Quality Program Manager, PA DEP. The Title V Compliance Certification may be emailed to EPA Region III at R3_APD_Permits@epa.gov in lieu of mailing a hard copy. However, in accordance with Title 25 PA Code § 127.513(5)(i), in no case shall the Title V Compliance Certification be submitted less often than annually. This may require that an interim

SECTION C. Site Level Requirements

Title V Compliance Certification (covering a period less than one year) be submitted to bring the facility into compliance with this schedule.

018 [25 Pa. Code §135.21]**Emission statements**

The owner or operator of each stationary source emitting oxides of nitrogen and/or VOCs shall provide the Department with a statement, in a form as the Department may prescribe, for classes or categories of sources, showing the actual emissions of oxides of nitrogen and VOCs from that source for each reporting period, a description of the method used to calculate the emissions and the time period over which the calculation is based. The statement shall contain a certification by a company officer or the plant manager that the information contained in the statement is accurate.

019 [40 CFR Part 60 Standards of Performance for New Stationary Sources §40 CFR 60.4]**Subpart A - General Provisions****Address.**

Sources at the facility are subject to the applicable requirements of the following regulations and shall comply with all applicable notification and reporting requirements contained in 40 CFR, Part 60,

Subpart OOO (Standards of Performance for Nonmetallic Mineral Processing Plants) and;

Subpart IIII (Standards of Performance for Stationary Compression Ignition Internal Combustion Engines)

and contained in 40 CFR, Part 63,

Subpart ZZZZ (National Emission Standards for Hazardous Pollutants for Stationary Reciprocating Internal Combustion Engines.) and;

Subpart DDDDD (National Emission Standards for Hazardous Pollutants for Major Sources: Industrial, Commercial, and Institutional Boilers and Process Heaters.) and;

Subpart UUUUU (National Emission Standards for Hazardous Pollutants for Coal- and Oil-fired Electric Steam Utility Steam Generating Units.).

In accordance with 40 CFR § 60.4 and 40 CFR § 63.13, copies of all requests, reports, applications, submittals and other communications shall be forwarded to both the Environmental Protection Agency and the Pennsylvania Department of Environmental Protection at the addresses shown below, unless otherwise noted:

Director, Air Protection Division
Environmental Protection Agency
Region III
Mail Code 3AP20
1650 Arch Street
Philadelphia, PA 19103-2029

PA Department of Environmental Protection
Regional Air Quality Program Manager
230 Chestnut Street
Meadville, PA 16335

This permit contains language from the Code of Federal Regulations (CFR). Should the wording of the federal citations of the conditions in this permit be changed in the CFR, the new wording shall supersede the language of this permit.

VI. WORK PRACTICE REQUIREMENTS.**# 020 [25 Pa. Code §127.444]****Compliance requirements.**

The permittee shall maintain and operate all the sources and control devices at this facility in accordance with manufacturer's specification and good operating practices.

**SECTION C. Site Level Requirements****VII. ADDITIONAL REQUIREMENTS.****# 021 [25 Pa. Code §123.42]****Exceptions**

The limitations for opacity (relating to limitations) shall not apply to a visible emission in any of the following instances:

- (1) When the presence of uncombined water is the only reason for failure of the emission to meet the limitations.
- (2) When the emission results from the operation of equipment used solely to train and test persons in observing the opacity of visible emissions.
- (3) When the emission results from sources specified in § 123.1 (a)(1)-(9) (relating to prohibition of certain fugitive emissions).
- (4) N/A.

022 [25 Pa. Code §123.43]**Measuring techniques**

Visible emissions may be measured using either of the following:

- (1) A device approved by the Department and maintained to provide accurate opacity measurements.
- (2) Observers, trained and qualified to measure plume opacity with the naked eye or with the aid of any devices approved by the Department.

023 [25 Pa. Code §127.441]**Operating permit terms and conditions.**

Mass emissions may be determined using engineering calculations based on fuel and raw material purchase records, manufacturers specifications, AP-42 emission factors, source test results, operating records, material balance methods, and/or other applicable methods with written Departmental approval.

024 [25 Pa. Code §127.441]**Operating permit terms and conditions.**

The plant manager is officially recognized as a delegated responsible official.

025 [25 Pa. Code §129.96]**Applicability**

(a) The NO_x requirements of this section and § § 129.97—129.100 apply Statewide to the owner and operator of a major NO_x emitting facility and the VOC requirements of this section and § § 129.97—129.100 apply Statewide to the owner and operator of a major VOC emitting facility that were in existence on or before July 20, 2012, for which a requirement or emission limitation, or both, has not been established in § § 129.51—129.52c, 129.54—129.69, 129.71—129.73, 129.75, 129.77, 129.101—129.107 and 129.301—129.310.

(b) N/A

(c) This section and § § 129.97—129.100 do not apply to the owner and operator of a NO_x air contamination source located at a major NO_x emitting facility that has the potential to emit less than 1 TPY of NO_x or a VOC air contamination source located at a major VOC emitting facility that has the potential to emit less than 1 TPY of VOC.

(d) N/A

[The Keystone Generating Station is both a major NO_x and VOC emitting facility and sources at the facility (Source IDs 031, 032, 037, 038, 101 - 104, 110, 113 - 115) have applicable requirements under RACT II (25 Pa. Code § § 129.96 - 129.100).]

VIII. COMPLIANCE CERTIFICATION.

No additional compliance certifications exist except as provided in other sections of this permit including Section B (relating to Title V General Requirements).



SECTION C. Site Level Requirements

IX. COMPLIANCE SCHEDULE.

No compliance milestones exist.

***** Permit Shield In Effect *****

**SECTION D. Source Level Requirements**

Source ID: 031

Source Name: BOILER 1 WITH LOW NOX BURNER

Source Capacity/Throughput: 8,717.000 MMBTU/HR

335.300 Tons/HR

COAL

63.170 Th Gal/HR

NO. 2 FUEL OIL

Conditions for this source occur in the following groups: G01
G02
G07
G09
G10

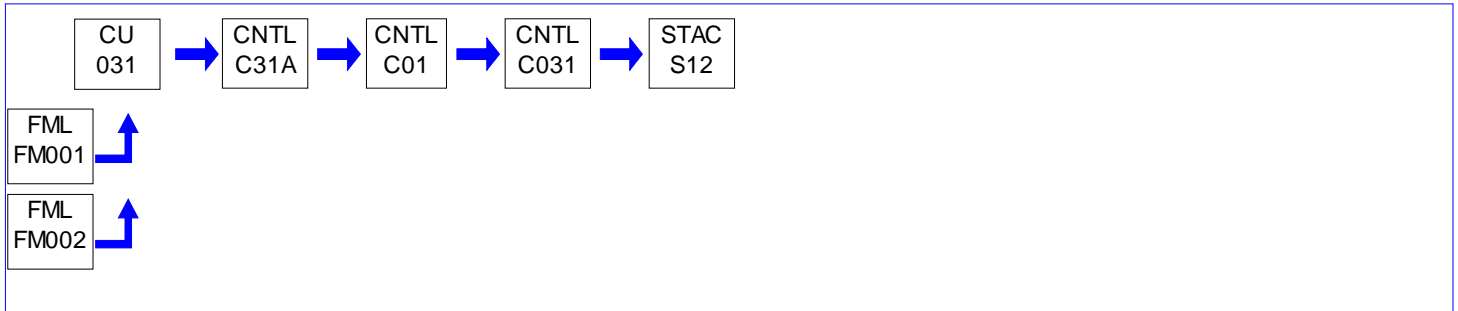

This source occurs in alternate operation OPTIONAL SORBENT INJECTION SYSTEM 1

I. RESTRICTIONS.

No additional requirements exist except as provided in other sections of this permit including Section B (Title V General Requirements) and/or Section E (Source Group Restrictions).

II. TESTING REQUIREMENTS.

No additional testing requirements exist except as provided in other sections of this permit including Section B (Title V General Requirements) and/or Section E (Source Group Restrictions).

III. MONITORING REQUIREMENTS.

No additional monitoring requirements exist except as provided in other sections of this permit including Section B (Title V General Requirements) and/or Section E (Source Group Restrictions).

IV. RECORDKEEPING REQUIREMENTS.

No additional record keeping requirements exist except as provided in other sections of this permit including Section B (Title V General Requirements) and/or Section E (Source Group Restrictions).

V. REPORTING REQUIREMENTS.

No additional reporting requirements exist except as provided in other sections of this permit including Section B (Title V General Requirements) and/or Section E (Source Group Restrictions).

VI. WORK PRACTICE REQUIREMENTS.**# 001 [25 Pa. Code §129.97]****Presumptive RACT requirements, RACT emission limitations and petition for alternative compliance schedule.**

The permittee shall install, maintain, and operate the source in accordance with the manufacturer's specifications and with good operating practices for the control of the VOC emissions from the combustion unit.

**SECTION D. Source Level Requirements****VII. ADDITIONAL REQUIREMENTS.****# 002 [25 Pa. Code §127.441]****Operating permit terms and conditions.**

[Additional regulatory authority for this condition is based on 40 CFR Sections 97.406(d)(2), 606(d)(2) and 806(d)(2).]

CSAPR Trading Program Title V Requirements

Description of CSAPR Monitoring Provisions

The CSAPR unit(s), and the unit-specific monitoring provisions at this source, are identified in the following table(s). These unit(s) are subject to the requirements for the CSAPR NOx Annual Trading Program, CSAPR SO2 Group 1 Trading Program and CSAPR NOx Ozone Season Group 2 Trading Program.

Table A - Unit ID: Boiler 1, Source ID 031)

1. Does the continuous emission monitoring system (CEMS) meet its requirements pursuant to 40 CFR Part 75, Subpart B (for SO2 monitoring) and 40 CFR Part 75, Subpart H (for NOx monitoring)?

Parameter

SO2	Yes
NOx	Yes
Heat Input	Yes

2. Does the CEMS have EPA-approved alternative monitoring system requirements pursuant to 40 CFR Part 75, Subpart E?

Parameter

SO2	No
NOx	No
Heat Input	No

1. The above description of the monitoring used by a unit does not change, create an exemption from, or otherwise affect the monitoring, recordkeeping, and reporting requirements applicable to the unit under 40 CFR 97.430 through 97.435 (CSAPR NOx Annual Trading Program), 97.630 through 97.635 (CSAPR SO2 Group 1 Trading Program), and 97.830 through 97.835 (CSAPR NOx Ozone Season Group 2 Trading Program). The monitoring, recordkeeping and reporting requirements applicable to each unit are included below in the standard conditions for the applicable TR trading programs.

2. Owners and operators must submit to the Administrator a monitoring plan for each unit in accordance with 40 CFR 75.53, 75.62 and 75.73, as applicable. The monitoring plan for each unit is available at the EPA's website at <http://www.epa.gov/airmarkets/emissions/monitoringplans.html>.

3. Owners and operators that want to use an alternative monitoring system must submit to the Administrator a petition requesting approval of the alternative monitoring system in accordance with 40 CFR Part 75, Subpart E and 40 CFR 75.66 and 97.435 (CSAPR NOx Annual Trading Program), 97.635 (CSAPR SO2 Group 1 Trading Program), and 97.835 (CSAPR NOx Ozone Season Group 2 Trading Program). The Administrator's response approving or disapproving any petition for an alternative monitoring system is available on the EPA's website at <http://www.epa.gov/airmarkets/emissions/petitions.html>.

4. Owners and operators that want to use an alternative to any monitoring, recordkeeping, or reporting requirement under 40 CFR 97.430 through 97.434 (CSAPR NOx Annual Trading Program), 97.630 through 97.634 (CSAPR SO2 Group 1 Trading Program) and 97.830 through 97.835 (CSAPR NOx Ozone Season Group 2 Trading Program) must submit to the Administrator a petition requesting approval of the alternative in accordance with 40 CFR 75.66 and 97.435 (CSAPR NOx Annual Trading Program), 97.635 (CSAPR SO2 Group 1 Trading Program), and 97.835 (CSAPR NOx Ozone Season Group 2 Trading Program). The Administrator's response approving or disapproving any petition for an alternative to a monitoring, recordkeeping, or reporting requirement is available on EPA's website at <http://www.epa.gov/airmarkets/emissions/petitions.html>.

**SECTION D. Source Level Requirements**

5. The descriptions of monitoring applicable to the unit included above meet the requirement of 40 CFR 97.430 through 97.434 (CSAPR NOx Annual Trading Program), 97.630 through 97.634 (CSAPR SO2 Group 1 Trading Program) and 97.830 through 97.835 (CSAPR NOx Ozone Season Group 2 Trading Program), and therefore minor permit modification procedures, in accordance with 40 CFR 70.7(e)(2)(i)(B) or 71.7(e)(1)(i)(B), may be used to add to or change this unit's monitoring system description.

[This restriction is attributable to 40 CFR Part 97, Subpart AAAAA—CSAPR NOX Annual Trading Program, Subpart CCCCC—CSAPR SO2 Group 1 Trading Program, and Subpart EEEEE—CSAPR NOx Ozone Season Group 2 Trading Program.]

***** Permit Shield in Effect. *****

**SECTION D. Source Level Requirements**

Source ID: 032

Source Name: BOILER 2 WITH LOW NOX BURNER

Source Capacity/Throughput: 8,717.000 MMBTU/HR
 335.300 Tons/HR COAL
 63.170 Th Gal/HR NO. 2 FUEL OIL

Conditions for this source occur in the following groups: G01
 G02
 G07
 G09
 G10

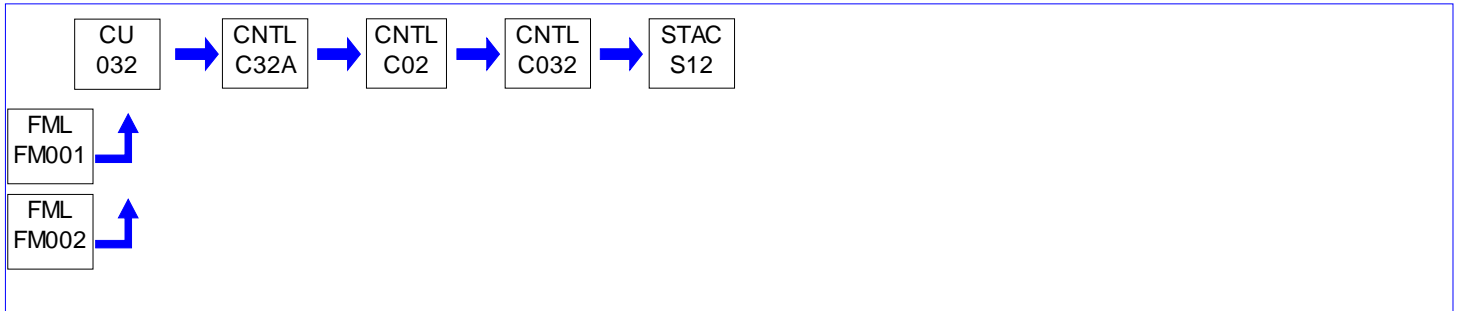

This source occurs in alternate operation OPTIONAL SORBENT INJECTION SYSTEM 2

I. RESTRICTIONS.

No additional requirements exist except as provided in other sections of this permit including Section B (Title V General Requirements) and/or Section E (Source Group Restrictions).

II. TESTING REQUIREMENTS.

No additional testing requirements exist except as provided in other sections of this permit including Section B (Title V General Requirements) and/or Section E (Source Group Restrictions).

III. MONITORING REQUIREMENTS.

No additional monitoring requirements exist except as provided in other sections of this permit including Section B (Title V General Requirements) and/or Section E (Source Group Restrictions).

IV. RECORDKEEPING REQUIREMENTS.

No additional record keeping requirements exist except as provided in other sections of this permit including Section B (Title V General Requirements) and/or Section E (Source Group Restrictions).

V. REPORTING REQUIREMENTS.

No additional reporting requirements exist except as provided in other sections of this permit including Section B (Title V General Requirements) and/or Section E (Source Group Restrictions).

VI. WORK PRACTICE REQUIREMENTS.**# 001 [25 Pa. Code §129.97]****Presumptive RACT requirements, RACT emission limitations and petition for alternative compliance schedule.**

The permittee shall install, maintain, and operate the source in accordance with the manufacturer's specifications and with good operating practices for the control of the VOC emissions from the combustion unit.

**SECTION D. Source Level Requirements****VII. ADDITIONAL REQUIREMENTS.****# 002 [25 Pa. Code §127.441]****Operating permit terms and conditions.**

[Additional regulatory authority for this condition is based on 40 CFR Sections 97.406(d)(2), 606(d)(2) and 806(d)(2).]

CSAPR Trading Program Title V Requirements

Description of CSAPR Monitoring Provisions

The CSAPR unit(s), and the unit-specific monitoring provisions at this source, are identified in the following table(s). These unit(s) are subject to the requirements for the CSAPR NOx Annual Trading Program, CSAPR SO2 Group 1 Trading Program and CSAPR NOx Ozone Season Group 2 Trading Program.

Table A - Unit ID: Boiler 2, Source ID 032)

1. Does the continuous emission monitoring system (CEMS) meet its requirements pursuant to 40 CFR Part 75, Subpart B (for SO2 monitoring) and 40 CFR Part 75, Subpart H (for NOx monitoring)?

Parameter

SO2	Yes
NOx	Yes
Heat Input	Yes

2. Does the CEMS have EPA-approved alternative monitoring system requirements pursuant to 40 CFR Part 75, Subpart E?

Parameter

SO2	No
NOx	No
Heat Input	No

1. The above description of the monitoring used by a unit does not change, create an exemption from, or otherwise affect the monitoring, recordkeeping, and reporting requirements applicable to the unit under 40 CFR 97.430 through 97.435 (CSAPR NOx Annual Trading Program), 97.630 through 97.635 (CSAPR SO2 Group 1 Trading Program), and 97.830 through 97.835 (CSAPR NOx Ozone Season Group 2 Trading Program). The monitoring, recordkeeping and reporting requirements applicable to each unit are included below in the standard conditions for the applicable TR trading programs.

2. Owners and operators must submit to the Administrator a monitoring plan for each unit in accordance with 40 CFR 75.53, 75.62 and 75.73, as applicable. The monitoring plan for each unit is available at the EPA's website at <http://www.epa.gov/airmarkets/emissions/monitoringplans.html>.

3. Owners and operators that want to use an alternative monitoring system must submit to the Administrator a petition requesting approval of the alternative monitoring system in accordance with 40 CFR Part 75, Subpart E and 40 CFR 75.66 and 97.435 (CSAPR NOx Annual Trading Program), 97.635 (CSAPR SO2 Group 1 Trading Program), and 97.835 (CSAPR NOx Ozone Season Group 2 Trading Program). The Administrator's response approving or disapproving any petition for an alternative monitoring system is available on the EPA's website at <http://www.epa.gov/airmarkets/emissions/petitions.html>.

4. Owners and operators that want to use an alternative to any monitoring, recordkeeping, or reporting requirement under 40 CFR 97.430 through 97.434 (CSAPR NOx Annual Trading Program), 97.630 through 97.634 (CSAPR SO2 Group 1 Trading Program) and 97.830 through 97.835 (CSAPR NOx Ozone Season Group 2 Trading Program) must submit to the Administrator a petition requesting approval of the alternative in accordance with 40 CFR 75.66 and 97.435 (CSAPR NOx Annual Trading Program), 97.635 (CSAPR SO2 Group 1 Trading Program), and 97.835 (CSAPR NOx Ozone Season Group 2 Trading Program). The Administrator's response approving or disapproving any petition for an alternative to a monitoring, recordkeeping, or reporting requirement is available on EPA's website at <http://www.epa.gov/airmarkets/emissions/petitions.html>.

SECTION D. Source Level Requirements

5. The descriptions of monitoring applicable to the unit included above meet the requirement of 40 CFR 97.430 through 97.434 (CSAPR NO_x Annual Trading Program), 97.630 through 97.634 (CSAPR SO₂ Group 1 Trading Program) and 97.830 through 97.835 (CSAPR NO_x Ozone Season Group 2 Trading Program), and therefore minor permit modification procedures, in accordance with 40 CFR 70.7(e)(2)(i)(B) or 71.7(e)(1)(i)(B), may be used to add to or change this unit's monitoring system description.

[This restriction is attributable to 40 CFR Part 97, Subpart AAAAA—CSAPR NO_x Annual Trading Program, Subpart CCCCC—CSAPR SO₂ Group 1 Trading Program, and Subpart EEEEE—CSAPR NO_x Ozone Season Group 2 Trading Program.]

***** Permit Shield in Effect. *****



SECTION D. Source Level Requirements

Source ID: 037

Source Name: AUX BOILER A

Source Capacity/Throughput: 138.000 MMBTU/HR

1.000 Th Gal/HR NO. 2 FUEL OIL

Conditions for this source occur in the following groups: G04
G11

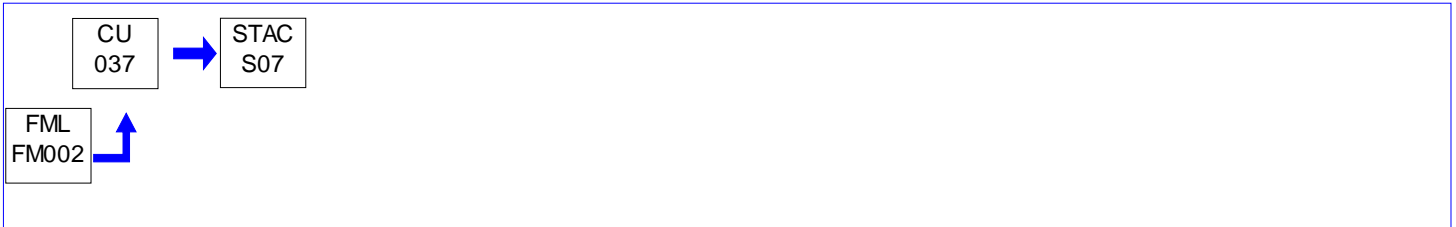

I. RESTRICTIONS.

No additional requirements exist except as provided in other sections of this permit including Section B (Title V General Requirements) and/or Section E (Source Group Restrictions).

II. TESTING REQUIREMENTS.

No additional testing requirements exist except as provided in other sections of this permit including Section B (Title V General Requirements) and/or Section E (Source Group Restrictions).

III. MONITORING REQUIREMENTS.

No additional monitoring requirements exist except as provided in other sections of this permit including Section B (Title V General Requirements) and/or Section E (Source Group Restrictions).

IV. RECORDKEEPING REQUIREMENTS.

No additional record keeping requirements exist except as provided in other sections of this permit including Section B (Title V General Requirements) and/or Section E (Source Group Restrictions).

V. REPORTING REQUIREMENTS.

No additional reporting requirements exist except as provided in other sections of this permit including Section B (Title V General Requirements) and/or Section E (Source Group Restrictions).

VI. WORK PRACTICE REQUIREMENTS.

No additional work practice requirements exist except as provided in other sections of this permit including Section B (Title V General Requirements) and/or Section E (Source Group Restrictions).

VII. ADDITIONAL REQUIREMENTS.

No additional requirements exist except as provided in other sections of this permit including Section B (Title V General Requirements) and/or Section E (Source Group Restrictions).

***** Permit Shield in Effect. *****

**SECTION D. Source Level Requirements**

Source ID: 038

Source Name: AUX BOILER B

Source Capacity/Throughput: 138.000 MMBTU/HR
1.000 Th Gal/HR NO 2. FUEL OIL

Conditions for this source occur in the following groups: G04
G11

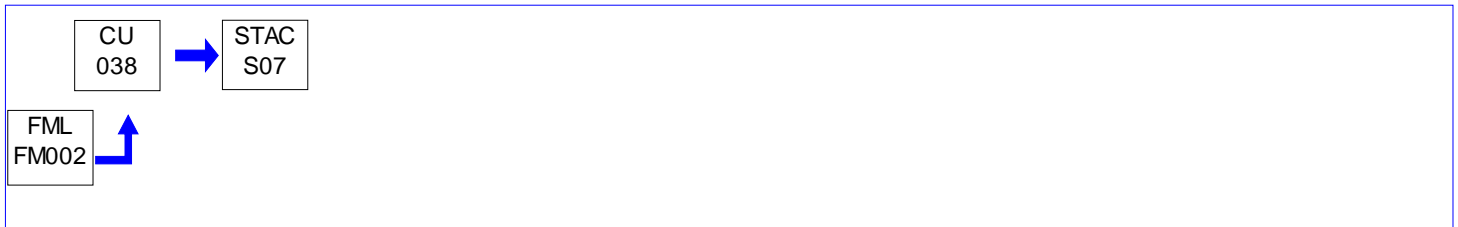
**I. RESTRICTIONS.**

No additional requirements exist except as provided in other sections of this permit including Section B (Title V General Requirements) and/or Section E (Source Group Restrictions).

II. TESTING REQUIREMENTS.

No additional testing requirements exist except as provided in other sections of this permit including Section B (Title V General Requirements) and/or Section E (Source Group Restrictions).

III. MONITORING REQUIREMENTS.

No additional monitoring requirements exist except as provided in other sections of this permit including Section B (Title V General Requirements) and/or Section E (Source Group Restrictions).

IV. RECORDKEEPING REQUIREMENTS.

No additional record keeping requirements exist except as provided in other sections of this permit including Section B (Title V General Requirements) and/or Section E (Source Group Restrictions).

V. REPORTING REQUIREMENTS.

No additional reporting requirements exist except as provided in other sections of this permit including Section B (Title V General Requirements) and/or Section E (Source Group Restrictions).

VI. WORK PRACTICE REQUIREMENTS.

No additional work practice requirements exist except as provided in other sections of this permit including Section B (Title V General Requirements) and/or Section E (Source Group Restrictions).

VII. ADDITIONAL REQUIREMENTS.

No additional requirements exist except as provided in other sections of this permit including Section B (Title V General Requirements) and/or Section E (Source Group Restrictions).

***** Permit Shield in Effect. *****

SECTION D. Source Level Requirements

Source ID: 115

Source Name: FIRED SPACE AND MISCELLANEOUS HEATERS

Source Capacity/Throughput: 4.400 Gal/HR Propane

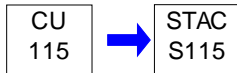
**I. RESTRICTIONS.****Emission Restriction(s).**

001 [25 Pa. Code §123.21]

General

(a) This section applies to sources except those subject to other provisions of this article, with respect to the control of sulfur compound emissions.

(b) No person may permit the emission into the outdoor atmosphere of sulfur oxides from a source in a manner that the concentration of the sulfur oxides, expressed as SO₂, in the effluent gas exceeds 500 parts per million, by volume, dry basis.

Throughput Restriction(s).

002 [25 Pa. Code §127.441]

Operating permit terms and conditions.

In accordance with RACT Operating Permit No. 03-000-027, the maximum heat input of each space heater shall be limited to 20 MMBtu/hr.

II. TESTING REQUIREMENTS.

No additional testing requirements exist except as provided in other sections of this permit including Section B (Title V General Requirements).

III. MONITORING REQUIREMENTS.

No additional monitoring requirements exist except as provided in other sections of this permit including Section B (Title V General Requirements).

IV. RECORDKEEPING REQUIREMENTS.

No additional record keeping requirements exist except as provided in other sections of this permit including Section B (Title V General Requirements).

V. REPORTING REQUIREMENTS.

No additional reporting requirements exist except as provided in other sections of this permit including Section B (Title V General Requirements).

VI. WORK PRACTICE REQUIREMENTS.

003 [25 Pa. Code §129.97]

Presumptive RACT requirements, RACT emission limitations and petition for alternative compliance schedule.

The permittee shall install, maintain, and operate each space heater in accordance with the manufacturer's specifications and with good operating practices.

**SECTION D. Source Level Requirements****VII. ADDITIONAL REQUIREMENTS.**

No additional requirements exist except as provided in other sections of this permit including Section B (Title V General Requirements).

***** Permit Shield in Effect. *****

SECTION D. Source Level Requirements

Source ID: 101 Source Name: UNIT 3 PEAKING DIESEL GENERATOR (3,600-BHP)
 Source Capacity/Throughput: 216.000 Gal/HR #2 Oil

Conditions for this source occur in the following groups: G05

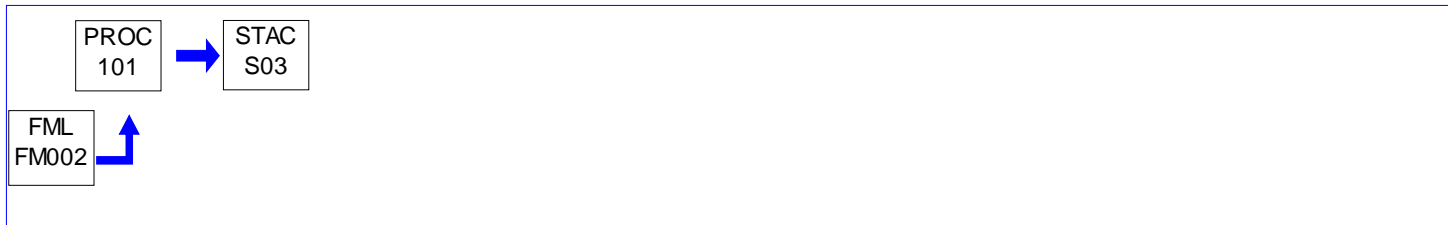
**I. RESTRICTIONS.**

No additional requirements exist except as provided in other sections of this permit including Section B (Title V General Requirements) and/or Section E (Source Group Restrictions).

II. TESTING REQUIREMENTS.

No additional testing requirements exist except as provided in other sections of this permit including Section B (Title V General Requirements) and/or Section E (Source Group Restrictions).

III. MONITORING REQUIREMENTS.

No additional monitoring requirements exist except as provided in other sections of this permit including Section B (Title V General Requirements) and/or Section E (Source Group Restrictions).

IV. RECORDKEEPING REQUIREMENTS.

No additional record keeping requirements exist except as provided in other sections of this permit including Section B (Title V General Requirements) and/or Section E (Source Group Restrictions).

V. REPORTING REQUIREMENTS.

No additional reporting requirements exist except as provided in other sections of this permit including Section B (Title V General Requirements) and/or Section E (Source Group Restrictions).

VI. WORK PRACTICE REQUIREMENTS.

No additional work practice requirements exist except as provided in other sections of this permit including Section B (Title V General Requirements) and/or Section E (Source Group Restrictions).

VII. ADDITIONAL REQUIREMENTS.

No additional requirements exist except as provided in other sections of this permit including Section B (Title V General Requirements) and/or Section E (Source Group Restrictions).

***** Permit Shield in Effect. *****

SECTION D. Source Level Requirements

Source ID: 102

Source Name: UNIT 4 PEAKING DIESEL GENERATOR (3,600-BHP)

Source Capacity/Throughput: 216.000 Gal/HR #2 Oil

Conditions for this source occur in the following groups: G05

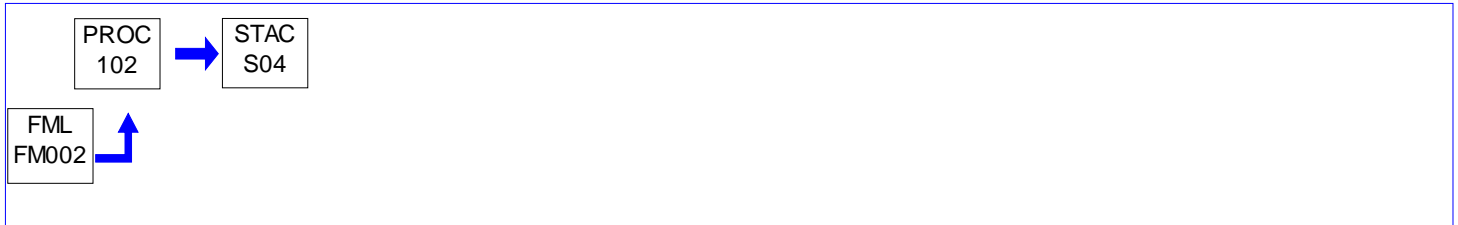
**I. RESTRICTIONS.**

No additional requirements exist except as provided in other sections of this permit including Section B (Title V General Requirements) and/or Section E (Source Group Restrictions).

II. TESTING REQUIREMENTS.

No additional testing requirements exist except as provided in other sections of this permit including Section B (Title V General Requirements) and/or Section E (Source Group Restrictions).

III. MONITORING REQUIREMENTS.

No additional monitoring requirements exist except as provided in other sections of this permit including Section B (Title V General Requirements) and/or Section E (Source Group Restrictions).

IV. RECORDKEEPING REQUIREMENTS.

No additional record keeping requirements exist except as provided in other sections of this permit including Section B (Title V General Requirements) and/or Section E (Source Group Restrictions).

V. REPORTING REQUIREMENTS.

No additional reporting requirements exist except as provided in other sections of this permit including Section B (Title V General Requirements) and/or Section E (Source Group Restrictions).

VI. WORK PRACTICE REQUIREMENTS.

No additional work practice requirements exist except as provided in other sections of this permit including Section B (Title V General Requirements) and/or Section E (Source Group Restrictions).

VII. ADDITIONAL REQUIREMENTS.

No additional requirements exist except as provided in other sections of this permit including Section B (Title V General Requirements) and/or Section E (Source Group Restrictions).

***** Permit Shield in Effect. *****

SECTION D. Source Level Requirements

Source ID: 103

Source Name: UNIT 5 PEAKING DIESEL GENERATOR (3,600-BHP)

Source Capacity/Throughput: 216.000 Gal/HR #2 Oil

Conditions for this source occur in the following groups: G05

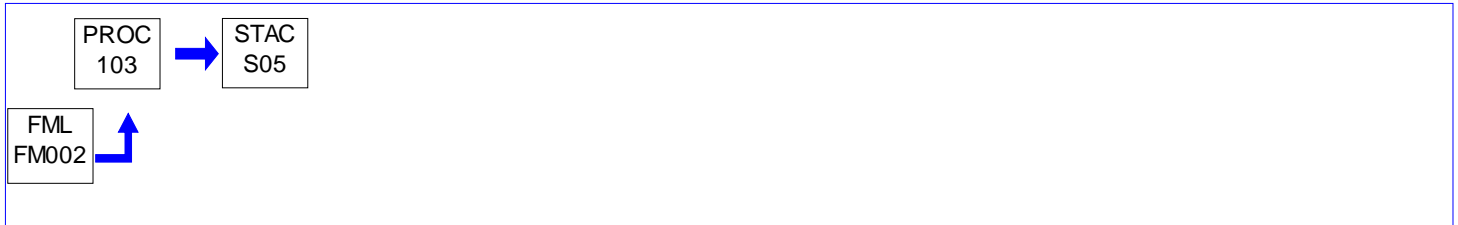
**I. RESTRICTIONS.**

No additional requirements exist except as provided in other sections of this permit including Section B (Title V General Requirements) and/or Section E (Source Group Restrictions).

II. TESTING REQUIREMENTS.

No additional testing requirements exist except as provided in other sections of this permit including Section B (Title V General Requirements) and/or Section E (Source Group Restrictions).

III. MONITORING REQUIREMENTS.

No additional monitoring requirements exist except as provided in other sections of this permit including Section B (Title V General Requirements) and/or Section E (Source Group Restrictions).

IV. RECORDKEEPING REQUIREMENTS.

No additional record keeping requirements exist except as provided in other sections of this permit including Section B (Title V General Requirements) and/or Section E (Source Group Restrictions).

V. REPORTING REQUIREMENTS.

No additional reporting requirements exist except as provided in other sections of this permit including Section B (Title V General Requirements) and/or Section E (Source Group Restrictions).

VI. WORK PRACTICE REQUIREMENTS.

No additional work practice requirements exist except as provided in other sections of this permit including Section B (Title V General Requirements) and/or Section E (Source Group Restrictions).

VII. ADDITIONAL REQUIREMENTS.

No additional requirements exist except as provided in other sections of this permit including Section B (Title V General Requirements) and/or Section E (Source Group Restrictions).

***** Permit Shield in Effect. *****



SECTION D. Source Level Requirements

Source ID: 104 Source Name: UNIT 6 PEAKING DIESEL GENERATOR (3,600-BHP)
Source Capacity/Throughput: 216.000 Gal/HR #2 Oil

Conditions for this source occur in the following groups: G05

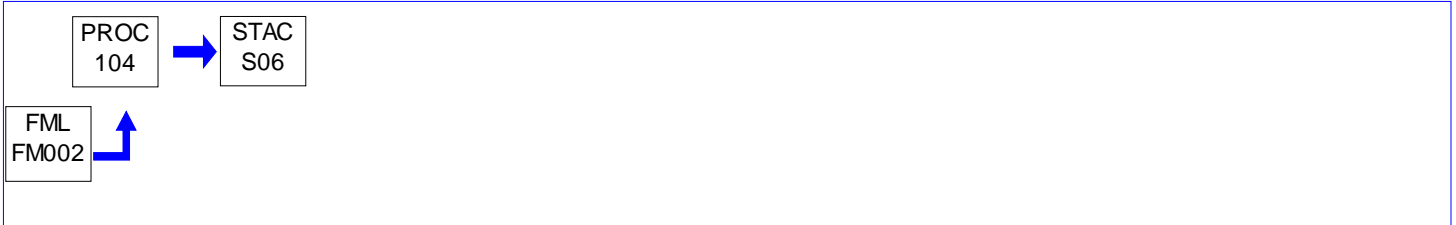

I. RESTRICTIONS.

No additional requirements exist except as provided in other sections of this permit including Section B (Title V General Requirements) and/or Section E (Source Group Restrictions).

II. TESTING REQUIREMENTS.

No additional testing requirements exist except as provided in other sections of this permit including Section B (Title V General Requirements) and/or Section E (Source Group Restrictions).

III. MONITORING REQUIREMENTS.

No additional monitoring requirements exist except as provided in other sections of this permit including Section B (Title V General Requirements) and/or Section E (Source Group Restrictions).

IV. RECORDKEEPING REQUIREMENTS.

No additional record keeping requirements exist except as provided in other sections of this permit including Section B (Title V General Requirements) and/or Section E (Source Group Restrictions).

V. REPORTING REQUIREMENTS.

No additional reporting requirements exist except as provided in other sections of this permit including Section B (Title V General Requirements) and/or Section E (Source Group Restrictions).

VI. WORK PRACTICE REQUIREMENTS.

No additional work practice requirements exist except as provided in other sections of this permit including Section B (Title V General Requirements) and/or Section E (Source Group Restrictions).

VII. ADDITIONAL REQUIREMENTS.

No additional requirements exist except as provided in other sections of this permit including Section B (Title V General Requirements) and/or Section E (Source Group Restrictions).

***** Permit Shield in Effect. *****

SECTION D. Source Level Requirements

Source ID: 105

Source Name: PLANT HAUL ROADS

Source Capacity/Throughput:

N/A

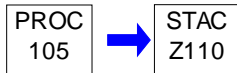
**I. RESTRICTIONS.**

No additional requirements exist except as provided in other sections of this permit including Section B (Title V General Requirements).

II. TESTING REQUIREMENTS.

No additional testing requirements exist except as provided in other sections of this permit including Section B (Title V General Requirements).

III. MONITORING REQUIREMENTS.

No additional monitoring requirements exist except as provided in other sections of this permit including Section B (Title V General Requirements).

IV. RECORDKEEPING REQUIREMENTS.

No additional record keeping requirements exist except as provided in other sections of this permit including Section B (Title V General Requirements).

V. REPORTING REQUIREMENTS.

No additional reporting requirements exist except as provided in other sections of this permit including Section B (Title V General Requirements).

VI. WORK PRACTICE REQUIREMENTS.**# 001 [25 Pa. Code §127.441]****Operating permit terms and conditions.**

In-plant roadways shall be paved and maintained so as to prevent fugitive emissions.

[From Plan Approval PA-03-00027E, Section D, Source ID 105, Condition #001. This condition is only applicable to haul roads whose construction was authorized by PA-03-00027E.]

002 [25 Pa. Code §127.441]**Operating permit terms and conditions.**

In-plant paved roadways shall be incorporated into the Facility's roadway watering and sweeping plan to prevent fugitive emissions. Roadway watering shall include the application of winterized surfactant as necessary during colder months.

[From Plan Approval PA-03-00027E, Section D, Source ID 105, Condition #002. This condition is only applicable to haul roads whose construction was authorized by PA-03-00027E.]

**SECTION D. Source Level Requirements****VII. ADDITIONAL REQUIREMENTS.**

No additional requirements exist except as provided in other sections of this permit including Section B (Title V General Requirements).

***** Permit Shield in Effect. *****

SECTION D. Source Level Requirements

Source ID: 106

Source Name: COAL HANDLING

Source Capacity/Throughput: 750.000 Tons/HR

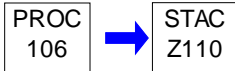
**I. RESTRICTIONS.****Throughput Restriction(s).****# 001 [25 Pa. Code §127.441]****Operating permit terms and conditions.**

Coal throughputs for the truck coal receiving facility shall not exceed the following in any consecutive 12-month period:

- a. 1,000,000 tons delivered to the truck coal receiving facility.
- b. 345,000 tons delivered to the storage piles.
- c. 1,4000,000 tons transferred from the surge pile.

[From Plan Approval PA-03-00027E, Section D, Source ID 106, Condition #001 and RFDs authorized 5/9/19 and 11/7/19. This condition is only applicable to equipment whose construction was authorized by PA-03-00027E.]

II. TESTING REQUIREMENTS.

No additional testing requirements exist except as provided in other sections of this permit including Section B (Title V General Requirements).

III. MONITORING REQUIREMENTS.

No additional monitoring requirements exist except as provided in other sections of this permit including Section B (Title V General Requirements).

IV. RECORDKEEPING REQUIREMENTS.**# 002 [25 Pa. Code §127.441]****Operating permit terms and conditions.**

The Owner/Operator shall maintain records of the following rolling 12-month totals (in tons):

- a. Coal delivered to the coal truck receiving facility.
- b. Coal delivered to the storage piles.
- c. Coal transferred from the surge pile to the coal truck receiving facility.

[From Plan Approval PA-03-00027E, Section D, Source ID 106, Condition #002. This condition is only applicable to equipment whose construction was authorized by PA-03-00027E.]

**SECTION D. Source Level Requirements****V. REPORTING REQUIREMENTS.**

No additional reporting requirements exist except as provided in other sections of this permit including Section B (Title V General Requirements).

VI. WORK PRACTICE REQUIREMENTS.**# 003 [25 Pa. Code §127.441]****Operating permit terms and conditions.**

Coal shall be stockpiled in such a manner that it may be adequately wetted by the on-site pressurized water truck, or by surfactant application, to control fugitive emissions as necessary.

[From Plan Approval PA-03-00027E, Section D, Source ID 106, Condition #005. This condition is only applicable to equipment whose construction was authorized by PA-03-00027E.]

004 [25 Pa. Code §127.441]**Operating permit terms and conditions.**

All loaded coal trucks entering the Facility shall be properly covered by a tarp so as to prevent fugitive emissions from crossing the property line. Notice of truck tarping requirements shall be clearly posted on site.

[From Plan Approval PA-03-00027E, Section D, Source ID 106, Condition #004. This condition is only applicable to equipment whose construction was authorized by PA-03-00027E.]

005 [25 Pa. Code §127.441]**Operating permit terms and conditions.**

Coal shall be stockpiled in such a manner that it is screened by wind barriers to control fugitive emissions.

[From Plan Approval PA-03-00027E, Section D, Source ID 106, Condition #006. This condition is only applicable to equipment whose construction was authorized by PA-03-00027E.]

006 [25 Pa. Code §127.441]**Operating permit terms and conditions.**

All conveying equipment and front-end loaders used to stockpile and transfer coal shall maintain a minimal amount of drop height at all times so as to prevent fugitive emissions.

[From Plan Approval PA-03-00027E, Section D, Source ID 106, Condition #007. This condition is only applicable to equipment whose construction was authorized by PA-03-00027E.]

007 [25 Pa. Code §127.441]**Operating permit terms and conditions.**

All conveyors and transfer points shall be covered or partially enclosed.

[From Plan Approval PA-03-00027E, Section D, Source ID 106, Condition #008. This condition is only applicable to equipment whose construction was authorized by PA-03-00027E.]

VII. ADDITIONAL REQUIREMENTS.

No additional requirements exist except as provided in other sections of this permit including Section B (Title V General Requirements).

***** Permit Shield in Effect. *****

SECTION D. Source Level Requirements

Source ID: 107

Source Name: ASH DISPOSAL

Source Capacity/Throughput: 500.000 Tons/HR

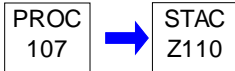
**I. RESTRICTIONS.****Emission Restriction(s).**

001 [25 Pa. Code §123.13]

Processes

(a)-(b) Not applicable.

(c) For processes not listed in subsection (b)(1), including but not limited to, coke oven battery waste heat stacks and autogeneous zinc coker waste heat stacks, the following shall apply:

(1) Prohibited emissions. No person may permit the emission into the outdoor atmosphere of particulate matter from any process not listed in subsection (b)(1) in a manner that the concentration of particulate matter in the effluent gas exceeds any of the following:

(i) .04 grain per dry standard cubic foot, when the effluent gas volume is less than 150,000 dry standard cubic feet per minute.

(ii)-(iii) Not applicable.

(2) Not applicable.

(d) Not applicable.

II. TESTING REQUIREMENTS.

No additional testing requirements exist except as provided in other sections of this permit including Section B (Title V General Requirements).

III. MONITORING REQUIREMENTS.

No additional monitoring requirements exist except as provided in other sections of this permit including Section B (Title V General Requirements).

IV. RECORDKEEPING REQUIREMENTS.

No additional record keeping requirements exist except as provided in other sections of this permit including Section B (Title V General Requirements).

V. REPORTING REQUIREMENTS.

No additional reporting requirements exist except as provided in other sections of this permit including Section B (Title V General Requirements).

SECTION D. Source Level Requirements**VI. WORK PRACTICE REQUIREMENTS.****# 002 [25 Pa. Code §127.441]****Operating permit terms and conditions.**

The permittee shall perform a monthly preventative maintenance (PM) inspection of the control devices associated with the fly ash loading dust collector and maintain a PM log. The PM log shall, at a minimum, include the following:

- (i) The date of inspection/maintenance performed;
- (ii) Description of any problems or defects;
- (iii) Action taken to correct problem or defect; and
- (iv) Any routine maintenance performed.

[Authorization from RFD 3/28/16]

VII. ADDITIONAL REQUIREMENTS.

No additional requirements exist except as provided in other sections of this permit including Section B (Title V General Requirements).

***** Permit Shield in Effect. *****

SECTION D. Source Level Requirements

Source ID: 108

Source Name: FUGITIVE VOC/HAPS

Source Capacity/Throughput: 100.000 Gal/HR

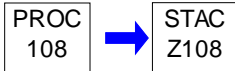
**I. RESTRICTIONS.**

No additional requirements exist except as provided in other sections of this permit including Section B (Title V General Requirements).

II. TESTING REQUIREMENTS.

No additional testing requirements exist except as provided in other sections of this permit including Section B (Title V General Requirements).

III. MONITORING REQUIREMENTS.

No additional monitoring requirements exist except as provided in other sections of this permit including Section B (Title V General Requirements).

IV. RECORDKEEPING REQUIREMENTS.

No additional record keeping requirements exist except as provided in other sections of this permit including Section B (Title V General Requirements).

V. REPORTING REQUIREMENTS.

No additional reporting requirements exist except as provided in other sections of this permit including Section B (Title V General Requirements).

VI. WORK PRACTICE REQUIREMENTS.

No additional work practice requirements exist except as provided in other sections of this permit including Section B (Title V General Requirements).

VII. ADDITIONAL REQUIREMENTS.

No additional requirements exist except as provided in other sections of this permit including Section B (Title V General Requirements).

***** Permit Shield in Effect. *****

SECTION D. Source Level Requirements

Source ID: 109

Source Name: NATURAL DRAFT COOLING TOWERS

Source Capacity/Throughput:

N/A

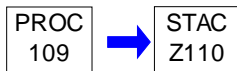
**I. RESTRICTIONS.**

No additional requirements exist except as provided in other sections of this permit including Section B (Title V General Requirements).

II. TESTING REQUIREMENTS.

No additional testing requirements exist except as provided in other sections of this permit including Section B (Title V General Requirements).

III. MONITORING REQUIREMENTS.

No additional monitoring requirements exist except as provided in other sections of this permit including Section B (Title V General Requirements).

IV. RECORDKEEPING REQUIREMENTS.

No additional record keeping requirements exist except as provided in other sections of this permit including Section B (Title V General Requirements).

V. REPORTING REQUIREMENTS.

No additional reporting requirements exist except as provided in other sections of this permit including Section B (Title V General Requirements).

VI. WORK PRACTICE REQUIREMENTS.

No additional work practice requirements exist except as provided in other sections of this permit including Section B (Title V General Requirements).

VII. ADDITIONAL REQUIREMENTS.

No additional requirements exist except as provided in other sections of this permit including Section B (Title V General Requirements).

***** Permit Shield in Effect. *****

**SECTION D. Source Level Requirements**

Source ID: 110

Source Name: EMERGENCY ENGINES (910HP GEN, 217 & 200HP FIRE PUMPS)

Source Capacity/Throughput: 81.000 Gal/HR DIESEL

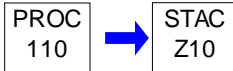
**I. RESTRICTIONS.****Emission Restriction(s).**

001 [25 Pa. Code §123.13]

Processes

In accordance with 25 Pa. Code §123.13(c)(1)(i), the permittee may not permit the emission into the outdoor atmosphere of particulate matter from this source in a manner that the concentration of particulate matter in the effluent gas exceeds 0.04 grain per dry standard cubic foot.

002 [25 Pa. Code §123.21]

General

No person may permit the emission into the outdoor atmosphere of sulfur oxides from a source in a manner that the concentration of the sulfur oxides, expressed as SO₂, in the effluent gas exceeds 500 parts per million, by volume, dry basis.

Operation Hours Restriction(s).

003 [25 Pa. Code §127.441]

Operating permit terms and conditions.

In accordance with RACT Operating Permit No. 03-000-027, emergency diesels and fire pumps shall each be operated less than 500 hours in each consecutive 12-month period.

II. TESTING REQUIREMENTS.

No additional testing requirements exist except as provided in other sections of this permit including Section B (Title V General Requirements).

III. MONITORING REQUIREMENTS.

No additional monitoring requirements exist except as provided in other sections of this permit including Section B (Title V General Requirements).

IV. RECORDKEEPING REQUIREMENTS.

004 [25 Pa. Code §127.441]

Operating permit terms and conditions.

In accordance with RACT Operating Permit No. 03-000-027, the permittee shall maintain an operating log, including records of hours of operation, fuel consumption, fuel type, and typical fuel analyses, for diesel generators, emergency generators, fire pump diesels, and all other sources subject to any operating permit restrictions in order to verify compliance with the Department's presumptive RACT limitations.

005 [40 CFR Part 63 NESHAPS for Source Categories §40 CFR 63.6655]

Subpart ZZZZ - National Emissions Standards for Hazardous Air Pollutants for Stationary Reciprocating Internal Combustion Engines**What records must I keep?**

(a)-(c) Not applicable.

**SECTION D. Source Level Requirements**

(d) You must keep the records required in Table 6 of this subpart to show continuous compliance with each emission or operating limitation that applies to you.

(e) You must keep records of the maintenance conducted on the stationary RICE in order to demonstrate that you operated and maintained the stationary RICE and after-treatment control device (if any) according to your own maintenance plan if you own or operate any of the following stationary RICE;

(1) Not applicable.

(2) An existing stationary emergency RICE.

(3) Not applicable.

(f) If you own or operate any of the stationary RICE in paragraphs (f)(1) through (2) of this section, you must keep records of the hours of operation of the engine that is recorded through the non-resettable hour meter. The owner or operator must document how many hours are spent for emergency operation, including what classified the operation as emergency and how many hours are spent for non-emergency operation. If the engine is used for the purposes specified in §63.6640(f)(2)(ii) or (iii) or §63.6640(f)(4)(ii), the owner or operator must keep records of the notification of the emergency situation, and the date, start time, and end time of engine operation for these purposes.

(1) An existing emergency stationary RICE with a site rating of less than or equal to 500 brake HP located at a major source of HAP emissions that does not meet the standards applicable to non-emergency engines.

(2) Not applicable.

The fire pump engines comprising Emergency Engines (Source 110) are subject to requirements in Table 6. This table states: For each: 9. Existing emergency and black start stationary RICE less than or equal to 500 HP located at a major source of HAPs you must demonstrate continuous compliance with the following Work or Management Practices by:

i. Operating and maintaining the stationary RICE according to the manufacturer's emission-related operation and maintenance instructions; or

ii. Develop and follow your own maintenance plan which must provide to the extent practicable for the maintenance and operation of the engine in a manner consistent with good air pollution control practice for minimizing emissions.

V. REPORTING REQUIREMENTS.

No additional reporting requirements exist except as provided in other sections of this permit including Section B (Title V General Requirements).

VI. WORK PRACTICE REQUIREMENTS.

006 [25 Pa. Code §127.441]

Operating permit terms and conditions.

The permittee shall verify compliance with the particulate mass emission rate of 25 PA Code §123.13, opacity standards of §123.41, and SO₂ limitations of §123.21 through the operation and maintenance of these sources in accordance with manufacturer specifications.

007 [25 Pa. Code §129.97]

Presumptive RACT requirements, RACT emission limitations and petition for alternative compliance schedule.

The permittee shall install, maintain, and operate the source in accordance with the manufacturer's specifications and with good operating practices.

**SECTION D. Source Level Requirements****# 008 [40 CFR Part 63 NESHAPS for Source Categories §40 CFR 63.6625]****Subpart ZZZZ - National Emissions Standards for Hazardous Air Pollutants for Stationary Reciprocating Internal Combustion Engines****What are my monitoring, installation, operation, and maintenance requirements?**

(a)-(d) Not applicable.

(e) If you own or operate any of the following stationary RICE, you must operate and maintain the stationary RICE and after-treatment control device (if any) according to the manufacturer's emission-related written instructions or develop your own maintenance plan which must provide to the extent practicable for the maintenance and operation of the engine in a manner consistent with good air pollution control practice for minimizing emissions:

(1) Not applicable.

(2) An existing emergency or black start stationary RICE with a site rating of less than or equal to 500 HP located at a major source of HAP emissions;

(3)-(10) Not applicable.

(f) If you own or operate an existing emergency stationary RICE with a site rating of less than or equal to 500 brake HP located at a major source of HAP emissions or an existing emergency stationary RICE located at an area source of HAP emissions, you must install a non-resettable hour meter if one is not already installed.

(g) Not applicable.

(h) If you operate a new, reconstructed, or existing stationary engine, you must minimize the engine's time spent at idle during startup and minimize the engine's startup time to a period needed for appropriate and safe loading of the engine, not to exceed 30 minutes, after which time the emission standards applicable to all times other than startup in Tables 1a, 2a, 2c, and 2d to this subpart apply.

(i) If you own or operate a stationary CI engine that is subject to the work, operation or management practices in items 1 or 2 of Table 2c to this subpart or in items 1 or 4 of Table 2d to this subpart, you have the option of utilizing an oil analysis program in order to extend the specified oil change requirement in Tables 2c and 2d to this subpart. The oil analysis must be performed at the same frequency specified for changing the oil in Table 2c or 2d to this subpart. The analysis program must at a minimum analyze the following three parameters: Total Base Number, viscosity, and percent water content. The condemning limits for these parameters are as follows: Total Base Number is less than 30 percent of the Total Base Number of the oil when new; viscosity of the oil has changed by more than 20 percent from the viscosity of the oil when new; or percent water content (by volume) is greater than 0.5. If all of these condemning limits are not exceeded, the engine owner or operator is not required to change the oil. If any of the limits are exceeded, the engine owner or operator must change the oil within 2 business days of receiving the results of the analysis; if the engine is not in operation when the results of the analysis are received, the engine owner or operator must change the oil within 2 business days or before commencing operation, whichever is later. The owner or operator must keep records of the parameters that are analyzed as part of the program, the results of the analysis, and the oil changes for the engine. The analysis program must be part of the maintenance plan for the engine.

(j) Not applicable.

VII. ADDITIONAL REQUIREMENTS.**# 009 [40 CFR Part 63 NESHAPS for Source Categories §40 CFR 63.6590]****Subpart ZZZZ - National Emissions Standards for Hazardous Air Pollutants for Stationary Reciprocating Internal Combustion Engines****What parts of my plant does this subpart cover?**

This subpart applies to each affected source.

(a) Affected source. An affected source is any existing, new, or reconstructed stationary RICE located at a major or area

**SECTION D. Source Level Requirements**

source of HAP emissions, excluding stationary RICE being tested at a stationary RICE test cell/stand.

(1) Existing stationary RICE.

(i) For stationary RICE with a site rating of more than 500 brake horsepower (HP) located at a major source of HAP emissions, a stationary RICE is existing if you commenced construction or reconstruction of the stationary RICE before December 19, 2002.

(ii) For stationary RICE with a site rating of less than or equal to 500 brake HP located at a major source of HAP emissions, a stationary RICE is existing if you commenced construction or reconstruction of the stationary RICE before June 12, 2006.

(iii)-(iv) Not applicable.

(2)-(3) Not applicable.

(b) Stationary RICE subject to limited requirements.

(1)-(2) Not applicable.

(3) The following stationary RICE do not have to meet the requirements of this subpart and of subpart A of this part, including initial notification requirements:

(i)-(ii) Not applicable.

(iii) Existing emergency stationary RICE with a site rating of more than 500 brake HP located at a major source of HAP emissions that does not operate or is not contractually obligated to be available for more than 15 hours per calendar year for the purposes specified in §63.6640(f)(2)(ii) and (iii).

(iv)-(v) Not applicable.

(c) Not applicable.

[§63.6590(b)(3)(iii) applies to the 910 bhp Emergency Generator in this Source ID 110]

010 [40 CFR Part 63 NESHPAS for Source Categories §40 CFR 63.6602]

Subpart ZZZZ - National Emissions Standards for Hazardous Air Pollutants for Stationary Reciprocating Internal Combustion Engines

What emission limitations must I meet if I own or operate an existing stationary RICE with a site rating of equal to or less than 500 brake HP located at a major source of HAP emissions?

If you own or operate an existing stationary RICE with a site rating of equal to or less than 500 brake HP located at a major source of HAP emissions, you must comply with the emission limitations and other requirements in Table 2c to this subpart which apply to you. Compliance with the numerical emission limitations established in this subpart is based on the results of testing the average of three 1-hour runs using the testing requirements and procedures in §63.6620 and Table 4 to this subpart.

The fire pump engines comprising Emergency Engines (Source ID 110) are subject to requirements in Table 2c. This table states: For each: 1. Emergency stationary CI RICE and black start stationary CI RICE You must meet the following requirement, except during periods of startup:

a. Change oil and filter every 500 hours of operation or annually, whichever comes first.

b. Inspect air cleaner every 1,000 hours of operation or annually, whichever comes first, and replace as necessary;

c. Inspect all hoses and belts every 500 hours of operation or annually, whichever comes first, and replace as necessary.

**SECTION D. Source Level Requirements**

During periods of startup you must minimize the engine's time spent at idle and minimize the engine's startup time at startup to a period needed for appropriate and safe loading of the engine, not to exceed 30 minutes, after which time the non-startup emission limitations apply.

011 [40 CFR Part 63 NESHAPS for Source Categories §40 CFR 63.6605]**Subpart ZZZZ - National Emissions Standards for Hazardous Air Pollutants for Stationary Reciprocating Internal Combustion Engines****What are my general requirements for complying with this subpart?**

(a) You must be in compliance with the emission limitations, operating limitations, and other requirements in this subpart that apply to you at all times.

(b) At all times you must operate and maintain any affected source, including associated air pollution control equipment and monitoring equipment, in a manner consistent with safety and good air pollution control practices for minimizing emissions. The general duty to minimize emissions does not require you to make any further efforts to reduce emissions if levels required by this standard have been achieved. Determination of whether such operation and maintenance procedures are being used will be based on information available to the Administrator which may include, but is not limited to, monitoring results, review of operation and maintenance procedures, review of operation and maintenance records, and inspection of the source.

012 [40 CFR Part 63 NESHAPS for Source Categories §40 CFR 63.6640]**Subpart ZZZZ - National Emissions Standards for Hazardous Air Pollutants for Stationary Reciprocating Internal Combustion Engines****How do I demonstrate continuous compliance with the emission limitations, operating limitations, and other requirements?**

(a) You must demonstrate continuous compliance with each emission limitation, operating limitation, and other requirements in Tables 1a and 1b, Tables 2a and 2b, Table 2c, and Table 2d to this subpart that apply to you according to methods specified in Table 6 to this subpart.

(b) You must report each instance in which you did not meet each emission limitation or operating limitation in Tables 1a and 1b, Tables 2a and 2b, Table 2c, and Table 2d to this subpart that apply to you. These instances are deviations from the emission and operating limitations in this subpart. These deviations must be reported according to the requirements in §63.6650. If you change your catalyst, you must reestablish the values of the operating parameters measured during the initial performance test. When you reestablish the values of your operating parameters, you must also conduct a performance test to demonstrate that you are meeting the required emission limitation applicable to your stationary RICE.

(c) - (d) Not applicable.

(e) You must also report each instance in which you did not meet the requirements in Table 8 to this subpart that apply to you. If you own or operate a new or reconstructed stationary RICE with a site rating of less than or equal to 500 brake HP located at a major source of HAP emissions (except new or reconstructed 4SLB engines greater than or equal to 250 and less than or equal to 500 brake HP), a new or reconstructed stationary RICE located at an area source of HAP emissions, or any of the following RICE with a site rating of more than 500 brake HP located at a major source of HAP emissions, you do not need to comply with the requirements in Table 8 to this subpart: An existing 2SLB stationary RICE, an existing 4SLB stationary RICE, an existing emergency stationary RICE, an existing limited use stationary RICE, or an existing stationary RICE which fires landfill gas or digester gas equivalent to 10 percent or more of the gross heat input on an annual basis. If you own or operate any of the following RICE with a site rating of more than 500 brake HP located at a major source of HAP emissions, you do not need to comply with the requirements in Table 8 to this subpart, except for the initial notification requirements: a new or reconstructed stationary RICE that combusts landfill gas or digester gas equivalent to 10 percent or more of the gross heat input on an annual basis, a new or reconstructed emergency stationary RICE, or a new or reconstructed limited use stationary RICE.

(f) If you own or operate an emergency stationary RICE, you must operate the emergency stationary RICE according to the requirements in paragraphs (f)(1) through (4) of this section. In order for the engine to be considered an emergency stationary RICE under this subpart, any operation other than emergency operation, maintenance and testing, emergency demand response, and operation in non-emergency situations for 50 hours per year, as described in paragraphs (f)(1) through (4) of this section, is prohibited. If you do not operate the engine according to the requirements in paragraphs (f)(1)

**SECTION D. Source Level Requirements**

through (4) of this section, the engine will not be considered an emergency engine under this subpart and must meet all requirements for non-emergency engines.

(1) There is no time limit on the use of emergency stationary RICE in emergency situations.

(2) You may operate your emergency stationary RICE for any combination of the purposes specified in paragraphs (f)(2)(i) through (iii) of this section for a maximum of 100 hours per calendar year. Any operation for non-emergency situations as allowed by paragraphs (f)(3) and (4) of this section counts as part of the 100 hours per calendar year allowed by this paragraph (f)(2).

(i) Emergency stationary RICE may be operated for maintenance checks and readiness testing, provided that the tests are recommended by federal, state or local government, the manufacturer, the vendor, the regional transmission organization or equivalent balancing authority and transmission operator, or the insurance company associated with the engine. The owner or operator may petition the Administrator for approval of additional hours to be used for maintenance checks and readiness testing, but a petition is not required if the owner or operator maintains records indicating that federal, state, or local standards require maintenance and testing of emergency RICE beyond 100 hours per calendar year.

(ii) - (iii) Not applicable.

(3) Emergency stationary RICE located at major sources of HAP may be operated for up to 50 hours per calendar year in non-emergency situations. The 50 hours of operation in non-emergency situations are counted as part of the 100 hours per calendar year for maintenance and testing and emergency demand response provided in paragraph (f)(2) of this section. The 50 hours per year for non-emergency situations cannot be used for peak shaving or non-emergency demand response, or to generate income for a facility to supply power to an electric grid or otherwise supply power as part of a financial arrangement with another entity.

(4) Not applicable.

***** Permit Shield in Effect. *****

SECTION D. Source Level Requirements

Source ID: 111 Source Name: LIMESTONE HANDLING, PROCESSING, AND STORAGE OPERATIONS
 Source Capacity/Throughput: 74.850 Tons/HR LIMESTONE

Conditions for this source occur in the following groups: G03

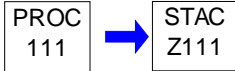
**I. RESTRICTIONS.****Emission Restriction(s).****# 001 [40 CFR Part 60 Standards of Performance for New Stationary Sources §40 CFR 60.672]****Subpart OOO - Standards of Performance for Nonmetallic Mineral Processing Plants Standard for particulate matter.**

Point source (stack) emissions of particulate matter from non-metallic mineral processing plants are subject to the following limitations:

The rate of emissions from point emission sources (such as bin vent filters) shall not exceed 0.022 gr/DSCF. (40 CFR § 60.672 (a))

The opacity of emissions from point emission sources shall not exceed 7%. (40 CFR § 60.672 (a))

[From Plan Approval, PA-03-00027B, Section D-Source ID 111 Condition 003.]

002 [40 CFR Part 60 Standards of Performance for New Stationary Sources §40 CFR 60.672]**Subpart OOO - Standards of Performance for Nonmetallic Mineral Processing Plants Standard for particulate matter.**

Fugitive source (non-stack) emissions of particulate matter from non-metallic mineral processing plants are subject to the following limitations:

The opacity of emissions from grinding mills, screens (except truck dumping), storage bins and enclosed truck or railcar operations shall not exceed 10%. (40 CFR § 60.672(b) and (d))

Opacity for this condition shall be measured using EPA Reference Method 9, found at 40 CFR 60, Appendix A. (40 CFR § 60.670)

[From Plan Approval, PA-03-00027B, Section D-Source ID 111 Condition 003.]

Throughput Restriction(s).**# 003 [25 Pa. Code §127.441]****Operating permit terms and conditions.**

The annual limestone throughputs shall be limited to 1,024,320 tons per year.

[From Plan Approval, PA-03-00027B, Section D-Source ID 111 Condition 001.]

II. TESTING REQUIREMENTS.

No additional testing requirements exist except as provided in other sections of this permit including Section B (Title V General Requirements) and/or Section E (Source Group Restrictions).

**SECTION D. Source Level Requirements****III. MONITORING REQUIREMENTS.****# 004 [25 Pa. Code §127.441]****Operating permit terms and conditions.**

- (a) The permittee shall install, operate, and maintain instrumentation to continuously monitor the differential pressure across the collector.
- (b) To ensure that fugitive emissions are not occurring during reclaiming limestone into the silo, or when limestone is being transferred into the limestone silo, the permittee shall, at least weekly when the source is in operation, observe the silo bin vent for the presence of visible fugitive emissions.

[From Plan Approval, PA-03-00027B, Section D-Source ID 111 Condition 004.]

IV. RECORDKEEPING REQUIREMENTS.**# 005 [25 Pa. Code §127.441]****Operating permit terms and conditions.**

- (a) In order to quantify emissions of PM and PM10 from the operations associated with Limestone Handling, Processing, and Storage Operations, the permittee shall maintain accurate and comprehensive records of the following information:
- (1) The total amount of limestone delivered by railcar each month.
 - (2) The total amount of limestone delivered by truck each month.
- (b) All records shall be maintained at the facility for a minimum of five (5) years and shall be made available to the Department upon request.

[From Plan Approval, PA-03-00027B, Section D-Source ID 111 Condition 005.]

V. REPORTING REQUIREMENTS.

No additional reporting requirements exist except as provided in other sections of this permit including Section B (Title V General Requirements) and/or Section E (Source Group Restrictions).

VI. WORK PRACTICE REQUIREMENTS.**# 006 [25 Pa. Code §127.441]****Operating permit terms and conditions.**

- (a) A sufficient quantity of spare fabric collector bags shall be kept on hand at all times in order to replace any bags that are worn or damaged due to deterioration resulting from routine operation of the source.

[From Plan Approval, PA-03-00027B, Section D-Source ID 111 Condition 006.]

007 [25 Pa. Code §127.441]**Operating permit terms and conditions.**

- a) All railcars delivering limestone shall be unloaded inside of an enclosure and shall be unloaded through the bottom of the railcars into a track level hopper.
- b) Limestone shall be reclaimed from the active limestone storage pile only by use of the underground reclaim system associated with the respective storage pile.

[From Plan Approval, PA-03-00027B, Section D-Source ID 111 Condition 007.]

008 [25 Pa. Code §127.441]**Operating permit terms and conditions.**

The permittee shall perform a monthly preventative maintenance (PM) inspection of the control devices and maintain a PM log. The PM log shall, at a minimum, include the following:

- (i) The date of inspection/maintenance performed;

**SECTION D. Source Level Requirements**

- (ii) Description of any problems or defects;
- (iii) Action taken to correct problem or defect; and
- (iv) Any routine maintenance performed.

VII. ADDITIONAL REQUIREMENTS.**# 009 [40 CFR Part 60 Standards of Performance for New Stationary Sources §40 CFR 60.670]****Subpart OOO - Standards of Performance for Nonmetallic Mineral Processing Plants****Applicability and designation of affected facility.**

(a)(1) Except as provided in paragraphs (a)(2), (b), (c), and (d) of this section, the provisions of this subpart are applicable to the following affected facilities in fixed or portable nonmetallic mineral processing plants: each crusher, grinding mill, screening operation, bucket elevator, belt conveyor, bagging operation, storage bin, enclosed truck or railcar loading station. Also, crushers and grinding mills at hot mix asphalt facilities that reduce the size of nonmetallic minerals embedded in recycled asphalt pavement and subsequent affected facilities up to, but not including, the first storage silo or bin are subject to the provisions of this subpart.

(2) The provisions of this subpart do not apply to the following operations: All facilities located in underground mines; plants without crushers or grinding mills above ground; and wet material processing operations (as defined in §60.671).

(b) An affected facility that is subject to the provisions of subparts F or I of this part or that follows in the plant process any facility subject to the provisions of subparts F or I of this part is not subject to the provisions of this subpart.

(c) Not applicable.

(d)(1) When an existing facility is replaced by a piece of equipment of equal or smaller size, as defined in §60.671, having the same function as the existing facility, and there is no increase in the amount of emissions, the new facility is exempt from the provisions of §§60.672, 60.674, and 60.675 except as provided for in paragraph (d)(3) of this section.

(2) An owner or operator complying with paragraph (d)(1) of this section shall submit the information required in §60.676(a).

(3) An owner or operator replacing all existing facilities in a production line with new facilities does not qualify for the exemption described in paragraph (d)(1) of this section and must comply with the provisions of §§60.672, 60.674 and 60.675.

(e) An affected facility under paragraph (a) of this section that commences construction, modification, or reconstruction after August 31, 1983, is subject to the requirements of this part.

(f) Table 1 of this subpart specifies the provisions of subpart A of this part 60 that do not apply to owners and operators of affected facilities subject to this subpart or that apply with certain exceptions.

[The Limestone Handling, Processing, and Storage Operations (Source ID 111) are subject to the applicable requirements of 40 CFR Part 60, Subpart OOO - Standards of Performance for Nonmetallic Mineral Processing Plants.]

***** Permit Shield in Effect. *****

**SECTION D. Source Level Requirements**

Source ID: 112

Source Name: GYPSUM PRODUCTION, PROCESSING, AND HANDLING OPERATIONS

Source Capacity/Throughput: 999.000 Tons/HR GYPSUM

Conditions for this source occur in the following groups: G03

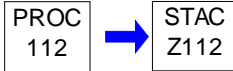
**I. RESTRICTIONS.****Emission Restriction(s).**

001 [25 Pa. Code §127.441]

Operating permit terms and conditions.

The permittee shall not stockpile more than 5,000 tons of gypsum at the ash landfill at any time.

[Authorization from RFD 8/25/16]

002 [25 Pa. Code §127.441]

Operating permit terms and conditions.

The permittee shall not exceed 28,750 tons of gypsum loaded out by truck from the gypsum stockpile at the ash landfill in any year.

[Authorization from RFD 8/25/16]

Throughput Restriction(s).

003 [25 Pa. Code §127.441]

Operating permit terms and conditions.

The annual rate of Gypsum processed shall not exceed 1,401,600 tons per year @ 10% moisture.

[From Plan Approval, PA-03-00027B, Section D-Source ID 112 Condition 001.]

II. TESTING REQUIREMENTS.

No additional testing requirements exist except as provided in other sections of this permit including Section B (Title V General Requirements) and/or Section E (Source Group Restrictions).

III. MONITORING REQUIREMENTS.

No additional monitoring requirements exist except as provided in other sections of this permit including Section B (Title V General Requirements) and/or Section E (Source Group Restrictions).

IV. RECORDKEEPING REQUIREMENTS.

004 [25 Pa. Code §127.441]

Operating permit terms and conditions.

(a) In order to quantify the emissions of PM and PM-10 from the operations associated with Gypsum Material Handling, the permittee shall maintain accurate and comprehensive records of the amount of gypsum sludge handled or processed on a monthly basis.

(b) The records shall be maintained at the facility for a period of five (5) years and be made available to the Department upon request.

SECTION D. Source Level Requirements

[From Plan Approval, PA-03-00027B, Section D-Source ID 112 Condition 002.]

005 [25 Pa. Code §127.441]

Operating permit terms and conditions.

The permittee shall maintain records of the daily amount and annual total of gypsum transferred to and from the gypsum stockpile at the ash landfill site.

[Authorization from RFD 8/25/16]

V. REPORTING REQUIREMENTS.

No additional reporting requirements exist except as provided in other sections of this permit including Section B (Title V General Requirements) and/or Section E (Source Group Restrictions).

VI. WORK PRACTICE REQUIREMENTS.

006 [25 Pa. Code §127.441]

Operating permit terms and conditions.

The permittee shall loadout gypsum from the stockpile only when no gypsum is available at the storage dome.

[Authorization from RFD 8/25/16]

VII. ADDITIONAL REQUIREMENTS.

No additional requirements exist except as provided in other sections of this permit including Section B (Title V General Requirements) and/or Section E (Source Group Restrictions).

***** Permit Shield in Effect. *****

SECTION D. Source Level Requirements

Source ID: 113 Source Name: EMERGENCY QUENCH PUMPS/ENGINES (2-130HP & 2,328-BHP)
 Source Capacity/Throughput: 140.000 Gal/HR Diesel Fuel

Conditions for this source occur in the following groups: G08

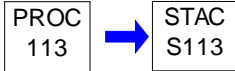
**I. RESTRICTIONS.****Emission Restriction(s).****# 001 [25 Pa. Code §123.13]****Processes**

(a)-(b) Not applicable.

(c) For processes not listed in subsection (b)(1), including but not limited to, coke oven battery waste heat stacks and autogeneous zinc coker waste heat stacks, the following shall apply:

(1) Prohibited emissions. No person may permit the emission into the outdoor atmosphere of particulate matter from any process not listed in subsection (b)(1) in a manner that the concentration of particulate matter in the effluent gas exceeds any of the following:

(i) .04 grain per dry standard cubic foot, when the effluent gas volume is less than 150,000 dry standard cubic feet per minute.

(ii)-(iii) Not applicable.

(2) Not applicable.

(d) Not applicable.

002 [25 Pa. Code §123.21]**General**

The permittee shall not allow emissions of sulfur oxides from each engine in such a manner that the concentration of sulfur oxides, expressed as SO₂, in the effluent gas exceeds 500 parts per million by volume, dry basis.

[From Plan Approval, PA-03-00027B, Section D-Source ID 113 Condition 001.]

(Compliance with this condition is assured by meeting Condition 005 for Source ID 113.)

003 [25 Pa. Code §127.441]**Operating permit terms and conditions.**

Visible emissions from each diesel engine shall not exceed the following limitations:

Equal to or greater than 10% for a period or periods aggregating more than three (3) minutes in any one (1) hour; and equal to or greater than 30% at any time.

[From Plan Approval, PA-03-00027B, Section D-Source ID 113 Condition 003.]

004 [25 Pa. Code §127.441]**Operating permit terms and conditions.**

(a) Emissions from each diesel-fired engine, associated with the installation of the FGD system, shall not exceed the following limits

SECTION D. Source Level Requirements

- (1) 6.9 gms of NOx/bhp-hr
- (2) 2.6 gms of CO/bhp-hr
- (3) 1.0 gms of THC/bhp-hr
- (4) 0.4 gm of PM/bhp-hr

[From Plan Approval, PA-03-00027B, Section D-Source ID 113 Condition 005.]

Fuel Restriction(s).

005 [25 Pa. Code §123.22]

Combustion units

In order to assure compliance with paragraph (a) above, the permittee shall limit the sulfur content of the diesel fuel used in the engines to 0.2% (by weight) or less.

[From Plan Approval, PA-03-00027B, Section D-Source ID 113 Condition 002.]

Operation Hours Restriction(s).

006 [25 Pa. Code §127.441]

Operating permit terms and conditions.

Operation of each Emergency Quench Pumps/Engine shall be limited to less than 500 hours in any 12-month rolling period.

[From Plan Approval, PA-03-00027B, Section D-Source ID 113 Condition 004.]

II. TESTING REQUIREMENTS.

No additional testing requirements exist except as provided in other sections of this permit including Section B (Title V General Requirements) and/or Section E (Source Group Restrictions).

III. MONITORING REQUIREMENTS.

No additional monitoring requirements exist except as provided in other sections of this permit including Section B (Title V General Requirements) and/or Section E (Source Group Restrictions).

IV. RECORDKEEPING REQUIREMENTS.

007 [25 Pa. Code §127.441]

Operating permit terms and conditions.

- (a) The permittee shall record the number of hours each engine operates on a monthly basis.
- (b) The permittee shall keep records of the amount, type, and analysis of fuel used in each engine on a monthly basis.

[From Plan Approval, PA-03-00027B, Section D-Source ID 113 Condition 006.]

V. REPORTING REQUIREMENTS.

No additional reporting requirements exist except as provided in other sections of this permit including Section B (Title V General Requirements) and/or Section E (Source Group Restrictions).

VI. WORK PRACTICE REQUIREMENTS.

008 [25 Pa. Code §129.97]

Presumptive RACT requirements, RACT emission limitations and petition for alternative compliance schedule.

The permittee shall install, maintain, and operate the source in accordance with the manufacturer's specifications and with

**SECTION D. Source Level Requirements**

good operating practices.

VII. ADDITIONAL REQUIREMENTS.

No additional requirements exist except as provided in other sections of this permit including Section B (Title V General Requirements) and/or Section E (Source Group Restrictions).

***** Permit Shield in Effect. *****

SECTION D. Source Level Requirements

Source ID: 114

Source Name: EMERGENCY DIESEL GENERATOR (1,474-BHP ENG., 1,000-KW OUTPUT)

Source Capacity/Throughput:

74.000 Gal/HR

Diesel Fuel

Conditions for this source occur in the following groups: G08

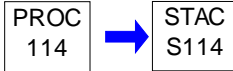
**I. RESTRICTIONS.****Emission Restriction(s).****# 001 [25 Pa. Code §123.13]****Processes**

(a) Subsections (b) and (c) apply to all processes except combustion units, incinerators and pulp mill smelt dissolving tanks.

(b) Not applicable.

(c) For processes not listed in subsection (b)(1), including but not limited to, coke oven battery waste heat stacks and autogeneous zinc coker waste heat stacks, the following shall apply:

(1) Prohibited emissions. No person may permit the emission into the outdoor atmosphere of particulate matter from any process not listed in subsection (b)(1) in a manner that the concentration of particulate matter in the effluent gas exceeds any of the following:

(i) .04 grain per dry standard cubic foot, when the effluent gas volume is less than 150,000 dry standard cubic feet per minute.

(ii)-(iii) Not applicable.

(2) Not applicable.

(d) Not applicable.

002 [25 Pa. Code §123.21]**General**

(a) This section applies to sources except those subject to other provisions of this article, with respect to the control of sulfur compound emissions.

(b) No person may permit the emission into the outdoor atmosphere of sulfur oxides from a source in a manner that the concentration of the sulfur oxides, expressed as SO₂, in the effluent gas exceeds 500 parts per million, by volume, dry basis.

003 [25 Pa. Code §127.441]**Operating permit terms and conditions.**

Visible emissions from the emergency diesel generator, approved to be installed under this plan approval, shall not exceed the following limitations (additional authority for this condition is derived from 40 CFR §89.113):

1) Equal to or greater than 10% for a period or periods aggregating more than three (3) minutes in any one (1) hour;

2) Greater than 20% during the acceleration mode;

3) Greater than 15% during the lugging mode; and

SECTION D. Source Level Requirements

4) Equal to or greater than 30% at any time.

[From Plan Approval, PA-03-00027B, Section D-Source ID 114 Condition 001.]

004 [25 Pa. Code §127.441]**Operating permit terms and conditions.**

This emergency diesel generator shall be certified to meet the following Tier 2 Emission Standards (Additional authority for this condition is derived from 40 CFR §89.112.):

- 1) 4.77 g/bhp-hr of NMHC + NO_x
- 2) 2.61 g/bhp-hr of CO
- 3) 0.15 g/bhp-hr of PM

[From Plan Approval, PA-03-00027B, Section D-Source ID 114 Condition 002.]

Operation Hours Restriction(s).**# 005 [25 Pa. Code §127.441]****Operating permit terms and conditions.**

Operation of this emergency diesel generator shall not exceed 500 hours in any consecutive 12-month period.

[From Plan Approval, PA-03-00027B, Section D-Source ID 114 Condition 005.]

II. TESTING REQUIREMENTS.

No additional testing requirements exist except as provided in other sections of this permit including Section B (Title V General Requirements) and/or Section E (Source Group Restrictions).

III. MONITORING REQUIREMENTS.**# 006 [25 Pa. Code §127.441]****Operating permit terms and conditions.**

The permittee shall:

- (a) Record hours of operation on a non-resettable hour meter.
- (b) Record hours of emergency operation, non-emergency operation, demand response, and testing and maintenance.
- (c) Record dates and times of engine inspections.
- (d) Maintain records on-site for a period of at least five (5) years.

IV. RECORDKEEPING REQUIREMENTS.**# 007 [25 Pa. Code §127.441]****Operating permit terms and conditions.**

The Owner/Operator shall maintain the following records for this emergency diesel generator:

- 1) Monthly and rolling 12-month totals of hours of operation; and
- 2) Monthly records of fuel usage including the amount, type, and a fuel analysis displaying sulfur content and either cetane index or aromatic content.

[From Plan Approval, PA-03-00027B, Section D-Source ID 114 Condition 006.]

**SECTION D. Source Level Requirements****V. REPORTING REQUIREMENTS.**

No additional reporting requirements exist except as provided in other sections of this permit including Section B (Title V General Requirements) and/or Section E (Source Group Restrictions).

VI. WORK PRACTICE REQUIREMENTS.

008 [25 Pa. Code §129.97]

Presumptive RACT requirements, RACT emission limitations and petition for alternative compliance schedule.

The permittee shall install, maintain, and operate the source in accordance with the manufacturer's specifications and with good operating practices.

VII. ADDITIONAL REQUIREMENTS.

No additional requirements exist except as provided in other sections of this permit including Section B (Title V General Requirements) and/or Section E (Source Group Restrictions).

***** Permit Shield in Effect. *****

**SECTION D. Source Level Requirements**

Source ID: 116

Source Name: SORBENT HANDLING AND STORAGE

Source Capacity/Throughput: 250.000 Lbs/HR CALCIUM HYDRATE/UNIT

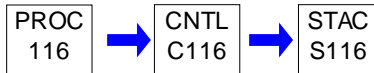
**I. RESTRICTIONS.****Emission Restriction(s).**

001 [25 Pa. Code §127.441]

Operating permit terms and conditions.

Visible emissions from each sorbent storage silo shall not equal or exceed 10% opacity at any time.

[From Plan Approval PA-03-00027B, Section D, Source ID 116, Condition #001.]

002 [25 Pa. Code §127.441]

Operating permit terms and conditions.

Bin vent filters shall be designed to achieve an outlet particulate matter concentration not to exceed 0.005 gr/dscf.

[From Plan Approval PA-03-00027B, Section D, Source ID 116, Condition #003.]

Throughput Restriction(s).

003 [25 Pa. Code §127.441]

Operating permit terms and conditions.

Deliveries to the facility of sorbent shall not exceed 35,040 tons in any consecutive 12-month period.

[From Plan Approval PA-03-00027B, Section D, Source ID 116, Condition #002.]

II. TESTING REQUIREMENTS.

No additional testing requirements exist except as provided in other sections of this permit including Section B (Title V General Requirements).

III. MONITORING REQUIREMENTS.

004 [25 Pa. Code §127.441]

Operating permit terms and conditions.

The Owner/Operator shall monitor and record the sorbent injection rate into the flue gas stream for both Unit 1 and 2 at a minimum of once during each hour of operation.

[From Plan Approval PA-03-00027B, Section D, Source ID 116, Condition #005.]

IV. RECORDKEEPING REQUIREMENTS.

005 [25 Pa. Code §127.441]

Operating permit terms and conditions.

The Owner/Operator shall maintain the following comprehensive and accurate records:

- 1) A rolling 12-month total (in tons) of the amount sorbent delivered to the facility.

SECTION D. Source Level Requirements

2) The manufacturer's recommended maintenance schedule and any maintenance activities performed on the sorbent injection systems and bin vent filters.

[From Plan Approval PA-03-00027B, Section D, Source ID 116, Condition #006.]

V. REPORTING REQUIREMENTS.

No additional reporting requirements exist except as provided in other sections of this permit including Section B (Title V General Requirements).

VI. WORK PRACTICE REQUIREMENTS.**# 006 [25 Pa. Code §127.25]****Compliance requirement.**

Sorbent storage silos shall not be loaded and sorbent shall not be injected into the flue gas stream unless the enclosed pneumatic transfer equipment and bin vent filters are operating properly.

[From Plan Approval PA-03-00027B, Section D, Source ID 116, Condition #008.]

007 [25 Pa. Code §127.441]**Operating permit terms and conditions.**

The permittee shall perform a monthly preventative maintenance (PM) inspection of the control devices and maintain a PM log. The PM log shall, at a minimum, include the following:

- (i) The date of inspection/maintenance performed;
- (ii) Description of any problems or defects;
- (iii) Action taken to correct problem or defect; and
- (iv) Any routine maintenance performed.

VII. ADDITIONAL REQUIREMENTS.

No additional requirements exist except as provided in other sections of this permit including Section B (Title V General Requirements).

***** Permit Shield in Effect. *****

**SECTION E. Source Group Restrictions.**

Group Name: G01

Group Description: Main Boilers #1 and #2

Sources included in this group

ID	Name
031	BOILER 1 WITH LOW NOX BURNER
032	BOILER 2 WITH LOW NOX BURNER

I. RESTRICTIONS.**Emission Restriction(s).****# 001 [25 Pa. Code §123.11]****Combustion units**

The particulate matter emission rate from either Main Boiler #1 or Main Boiler #2 shall not exceed 0.1 lb/MMBtu of heat input.

[Compliance with this condition is assured by the requirement for this Source Group to limit the emission of filterable particulate from each boiler to either 0.03 lb/MMBtu or 0.3 lb/MWh.]

002 [25 Pa. Code §123.22]**Combustion units**

(a)(1) No person may permit the emission into the outdoor atmosphere of sulfur oxides, expressed as SO₂, from a combustion unit in excess of the rate of 4 lbs/MMBtu over any 1-hour period except as provided in paragraph (4).

(Paragraph (4) states SO₂ emission limits when firing solid fossil fuel. Main Boilers #1 and #2 at start-up may operate on No. 2 Fuel Oil alone.)

[The Keystone Station is not located in an air basin. Compliance with this condition is ensured by compliance with Conditions 006 and 008.]

003 [25 Pa. Code §123.22]**Combustion units**

The following applies to solid fossil fueled combustion units with a rated capacity greater than or equal to 250 MMBtu/hr:

(a)(4)(iii) No person subject to this paragraph may permit the emission into the outdoor atmosphere of sulfur oxides, expressed as SO₂, from a combustion unit in excess of the rates set forth in the following table:

3.7 lbs of SO₂/MMBtu of heat input not to be exceeded on a 30-day rolling average basis, updated daily. (Compliance with this condition is assured by meeting Condition 006.)

4.0 lbs of SO₂/MMBtu of heat input not to be exceeded on a more than 2-calendar days on 30-day rolling average basis, updated daily.

4.8 lbs of SO₂/MMBtu of heat input not to be exceeded on any calendar day.

(These emission limits apply to Main Boiler #1 and Main Boiler #2 individually, when combusting coal.)

[The Keystone Station is not located in an air basin. Compliance with this condition is ensured by compliance with Conditions 006 and 008.]

004 [25 Pa. Code §127.441]**Operating permit terms and conditions.**

In accordance with RACT Operating Permit No. 03-000-027, emissions of NO_x (nitrogen oxides, expressed as NO₂) from either of Main Boilers #1 or #2 shall not exceed 0.45 pounds per million BTU, based on a thirty (30) day rolling average.

**SECTION E. Source Group Restrictions.****# 005 [25 Pa. Code §127.441]****Operating permit terms and conditions.**

As established in Plan Approval PA-03-00027A, the emission of ammonia caused by reagent injection in the SCR systems shall not exceed 5 ppmv at stack conditions as determined by USEPA Conditional Test Method (CTM-027), Procedure for Collection and Analysis of Ammonia in Stationary Sources or other procedure approved by the Department. The 5 ppmv ammonia slip limit ensures compliance with the existing ammonia emission limitation. The ammonia injection rate limitation contained in Operating Permit OP-03-306-002 is superseded by this condition.

006 [25 Pa. Code §127.441]**Operating permit terms and conditions.**

The SO₂ emission rate from either Main Boiler #1 or Main Boiler #2 shall not exceed the following limit:

- (a) 1.2 lbs of SO₂/MMBtu of heat input on a 30-day rolling average basis, updated daily.

[From Plan Approval, PA-03-00027B, Section E-Source Group 1 Condition 003.]

007 [25 Pa. Code §127.441]**Operating permit terms and conditions.**

The emission rate of PM₁₀ (consisting of both the filterable and condensable fractions of PM₁₀) from either Main Boiler #1 or Main Boiler #2 shall not exceed 0.1 lb/MMBtu of heat input.

[From Plan Approval, PA-03-00027B, Section E-Source Group 1 Condition 005.]

008 [25 Pa. Code §127.441]**Operating permit terms and conditions.**

The permittee shall not use Fuelsolv HG 2610 additive to Unit 1 and 2 at a rate greater than 284 gallons per day.

[Authorization from RFD 10/04/19]

009 [25 Pa. Code §127.441]**Operating permit terms and conditions.**

The SO₂ emission rate from Main Boiler #1 and Main Boiler #2 combined shall not exceed 9,600 lbs/hr on a 24-hour (daily) block average basis.

The permittee shall use its Department certified CEMS to demonstrate compliance with this emission limitation.

[Authorization from Consent Order dated October 11, 2017]

II. TESTING REQUIREMENTS.**# 010 [25 Pa. Code §127.441]****Operating permit terms and conditions.**

1. The permittee shall conduct source testing for particulate (Filterable only.) and PM-10 (Both filterable and condensable.) from the stacks of Boiler #1 and Boiler #2, within four (4) calendar quarters of the issuance of this Operating Permit and subsequent source tests shall be conducted no less often than once every two (2) years. Stack testing conducted within the two (2) year period prior to the issuance of this TVOP may be used to meet the requirements of this condition. However, should either boiler qualify as a Low Emitting EGU (LEE) for filterable particulate under 40 CFR 63.10005(h), subsequent testing for particulate, PM₁₀, and PM_{2.5} shall take place within every three (3) year period, for as long as the unit continues to qualify as a LEE for filterable particulate under 40 CFR Part 63, Subpart UUUUU. Should the unit cease to qualify as a LEE for filterable particulate under this subpart, a two (2) year testing cycle shall be reestablished.

2. Source testing shall be conducted on the stacks of Boiler #1 and Boiler #2 for H₂SO₄ no less often than once every five years. Testing for H₂SO₄ shall be conducted by EPA Method 8 or Department approved equivalent.

3. All testing shall be performed while Source IDs 031 and 032 are operating at no less than 90% of the maximum rated heat input, or under such other conditions, within the capacity of the equipment, as may be requested by the Department.

**SECTION E. Source Group Restrictions.**

Soot blowing and ash removal in the boiler must be conducted at normal intervals and testing may not be scheduled to avoid such periods as they are considered to be normal operations.

4. All testing shall be conducted in accordance with any applicable federal regulations and the most current version of the Source Testing Manual of the Department. The following federal reference methods, or other test methods approved by the Department prior to testing, shall be used.

a. 40 CFR 60, Appendix A, Methods 1-4 shall be used to determine the volumetric flow rate.

b. 40 CFR 60, Appendix A, Methods 5 and 202 shall be used to determine filterable particulate matter (FPM), filterable PM10 (Corrections may be necessary to account for interference by liquid water.), and condensable PM emission concentrations (grains/dscf) and emission rates (lbs/hour and lbs/MMBTU).

c. 40 CFR 60, Appendix A, Method 19 shall be used to determine the emission rates in lbs/MMBTU.

5. At least sixty (90) calendar days prior to commencing an emission testing program required by this condition, a test protocol shall be submitted to the Department for review and approval. The test protocol shall meet all applicable requirements specified in the most current version of the Source Testing Manual of the Department.

6. At least fifteen (15) calendar days prior to commencing an emission testing program required by this permit, written notification of the date and time of testing shall be provided to the appropriate Regional Office and to the Department of Environmental Protection, Bureau of Air Quality, Division of Source Testing and Monitoring. The notification and the testing shall not be made without prior receipt of a protocol acceptance letter from the Department. The Department is under no obligation to accept the results of any testing performed without adequate advance written notice to the Department of such testing.

7. The following process parameters shall be recorded at a minimum of 15-minute intervals during each test run (if possible). This data (including the units) and a summary thereof, averaged over each test run, must be included in the test report. Any exceptions to this recordkeeping requirement shall receive prior approval from the Department.

- a. Heat input rate of coal [MMBTU/hour]
- b. Coal feed rate to the boiler [tons/hour]
- c. Steam flow [lbs/hour]
- d. Steam temperature [°F]
- e. Steam pressure [psig]
- f. Soot blowing and/or ash removal (Yes/No)
- g. Oxygen level at the economizer [%]
- h. Flue gas pressure drop across the absorber [inches H₂O]
- i. Flue gas pressure drop across the mist eliminator [inches H₂O]
- j. Current draw of draft fans [amps]
- k. Output of powered electrical generator [mw]

8. Opacity observation of the Main Boiler Stack by EPA Method 9 shall be performed during each particulate test sampling run required by this condition. The results of these observations shall be used for verification of compliance by the required periodic EPA Method 9 stack observations.

9. Within fifteen (15) calendar days after completion of the on-site testing portion of an emission test program, an electronic mail notification shall be sent to the Department's Division of Source Testing and Monitoring and the appropriate Regional Office indicating the completion date of the on-site testing.

10. A complete test report shall be submitted to the Department no later than sixty (60) calendar days after completion of the on-site testing portion of an emission test program.

11. A complete test report shall include a summary of the emission results on the first page of the report indicating if each pollutant measured is within permitted limits and a statement of compliance or non-compliance with all applicable permit conditions. The summary results will include, at a minimum, the following information:

**SECTION E. Source Group Restrictions.**

- a. A statement that the owner or operator has reviewed the report from the emissions testing body and agrees with the findings;
- b. Permit number(s) and condition(s) which are the basis for the evaluation;
- c. Summary of results with respect to each applicable permit condition; and
- d. Statement of compliance or non-compliance with each applicable requirement.

12. All submittals shall meet all applicable requirements specified in Revision 3.3, or successor volume, of the Source Testing Manual of the Department.

13. The Department requires one electronic copy of all source test submissions (notifications, protocols, reports, supplemental information, etc.) to be sent to both the AQ Program Manager for the pertinent regional office and the PSIMS Administrator in Central Office (email addresses are provided below). Do not send submissions to anyone else, except the U.S. EPA, unless specifically directed to do so. To minimize the potential for rescheduling of the test, all protocols must be received at least 90 days prior to testing. Test reports must be received no later than 60 days after the completion of testing, unless a more stringent regulatory requirement applies. Any questions or concerns about source testing submissions can be sent to RA-EPstacktesting@pa.gov and the PSIMS Administrator will address them.

Electronic copies shall be emailed to the following:

Central Office
RA-EPstacktesting@pa.gov

Northwest Region
RA-EPNWstacktesting@pa.gov

14. The owner or operator shall ensure all federal reporting requirements contained in the applicable federal requirements are followed, including timelines more stringent than those contained herein. In the event of an inconsistency or any conflicting requirements between state and the federal, the most stringent provision, term, condition, method, or rule shall be used by default.

15. Alternative methodology may also be used, subject to Department approval.

III. MONITORING REQUIREMENTS.**# 011 [25 Pa. Code §123.25]****Monitoring requirements**

(a) (This section is applicable to Main Boilers #1 and #2 at the Keystone Station.):

(b) A source subject to this section shall install, operate and maintain continuous SO₂ monitoring systems in compliance with Chapter 139 Subchapter C (relating to requirements for continuous in-stack monitoring for stationary sources). Results of emission monitoring shall be submitted to the Department on a regular basis in compliance with Chapter 139 Subchapter C.

(c) Continuous SO₂ monitoring systems installed under this section shall meet the minimum data availability requirements in Chapter 139 Subchapter C.

(d) N/A.

(e) The Department may use the data from the SO₂ monitoring devices or from the alternative monitoring systems required by this section to enforce the emission limitations for SO₂ defined in this article.

(f) N/A.

(g) The Department may use the data from the SO₂ monitoring systems or from the alternative monitoring systems required by this section to determine compliance with the applicable emission limitations for SO₂ established in this article.

**SECTION E. Source Group Restrictions.****# 012 [25 Pa. Code §123.46]****Monitoring requirements**

In accordance with Title 25 PA Code Section 123.46(c), each unit, after the installation of the FGD system, is exempt from the requirements of Title 25 PA Code Section 123.46(b), relating to the installation and operation of a continuous opacity monitoring device.

013 [25 Pa. Code §123.51]**Monitoring requirements**

(a) This section applies to combustion units with a rated heat input of 250 million Btus per hour or greater and with an annual average capacity factor of greater than 30%.

(b) Sources subject to this section shall install, operate and maintain continuous nitrogen oxides monitoring systems and other monitoring systems to convert data to required reporting units in compliance with Chapter 139, Subchapter C (relating to requirements for continuous in-stack monitoring for statutory sources).

(c) Sources subject to this section shall submit results on a regular schedule and in a format acceptable to the Department and in compliance with Chapter 139, Subchapter C.

(d) Continuous nitrogen oxides monitoring systems installed under the requirements of this section shall meet the minimum data availability requirements in Chapter 139, Subchapter C.

(e) - (f) N/A.

014 [25 Pa. Code §127.441]**Operating permit terms and conditions.**

The Owner/Operator shall operate and maintain devices to monitor and record the following FGD System parameters at a frequency of at least once per day:

- a) Absorber pressure differential.
- b) Flue gas pressure drop across mist eliminators.
- c) Absorber inlet and outlet temperature.
- d) Absorber reaction tank pH.
- e) Absorber reaction tank gypsum slurry density.

[From Plan Approval, PA-03-00027B, Section E-Source Group 1 Condition 010.]

015 [25 Pa. Code §127.441]**Operating permit terms and conditions.**

The Owner/Operator shall read and record Visible Emissions for at least 1 hour each calendar week from the Main Boiler stack, using EPA Reference Method 9, found at 40 CFR 60, Appendix A, unless atmospheric conditions make such readings impossible.

[From Plan Approval, PA-03-00027B, Section E-Source Group 1 Condition 011.]

016 [25 Pa. Code §139.101]**General requirements.**

In accordance with the Department's "Continuous Source Monitoring Manual" the owner or operator shall observe the following requirements when performing any maintenance/calibration on the CEM system(s):

(A) MAINTENANCE:

1. Zero and upscale calibration error checks should be conducted immediately prior to maintenance, if possible.
2. Zero and upscale calibration error checks must be conducted immediately following any maintenance.
3. If the post maintenance zero or calibration error checks show calibration error in excess of twice the applicable performance specification, recalibration must be conducted in accordance with quarterly linearity check procedures in Paragraph (B)(2). Monitors may be calibrated in-situ.

**SECTION E. Source Group Restrictions.****(B) PERIODIC CALIBRATION:**

1. Calibration must be conducted at least daily for determination of measurement device zero and upscale calibration error on all measurement device ranges. The calibration must be performed as per the Department's "Continuous Source Monitoring Manual."
2. The monitoring system must be adjusted whenever the zero or upscale calibration error performance specification are exceeded.
3. The zero calibration error check must be conducted at a measurement level at or between 0% and 30% of measurement device range. The value selected must be lower than the lowest value that would be expected to occur under normal source operating conditions.
4. The calibration error check must be conducted at a measurement level at or between 40% and 100% of measurement device range unless an alternative level can be demonstrated to better represent normal source operating levels.

[From Department's Continuous Source Monitoring Manual (Revision No. 8 {Current revision at time of permit issuance.}), Quality Assurance Section, Subsections I.C.1 and 1.D.1.]

Approval of alternatives to these procedures (e.g., those per 40 CFR Part 75 [Acid Rain Program]) may be requested via submittal to the Chief of the Division of Source Testing and Monitoring, Bureau of Air Quality (BAQ). The Department has the authority to determine which alternatives are applicable.

[From Department's Continuous Source Monitoring Manual (Revision No. 8 {Current revision at time of permit issuance.}), Applicability Section]

017 [25 Pa. Code §139.101]**General requirements.**

- (a) At least once in every four calendar quarters in which the source operates for 168 hours or more, or within 720 source operating hours after the close of such four quarters, the permittee shall conduct a System Performance Audit in accordance with the relative accuracy test audit procedures listed in the Department's Continuous Source Monitoring Manual.
- (b) When eight consecutive calendar quarters elapse after the last System Performance Audit, a System Performance Audit must be conducted within 720 source-operating hours.
- (c) Notification of System Performance Audit testing must be provided to the Department's Source Testing and Monitoring, Continuous Emission Monitoring Section at least 21 days prior to testing.
- (d) Departmental approval must be obtained prior to the testing.
- (e) A periodic self-audit conducted for purposes of meeting the requirements of the Department's Continuous Source Monitoring Manual may not be conducted within 6 months of the previous successful periodic self-audit on the same existing, previously approved monitoring system to which no changes have been made.

[From Department's Continuous Source Monitoring Manual (Revision No. 8 {Current revision at time of permit issuance.}), Quality Assurance Section, Subsection I.E.]

IV. RECORDKEEPING REQUIREMENTS.**# 018 [25 Pa. Code §127.12b]****Plan approval terms and conditions.**

As established in Plan Approval PA-03-00027A and administratively amended into this Title V Operating Permit, the permittee shall keep a monthly log of all aqueous ammonia shipments delivered to this facility. These records shall be kept on-site for a period of five years and be made available to the Department upon request.

019 [25 Pa. Code §127.441]**Operating permit terms and conditions.**

The permittee shall maintain hourly and daily records of FuelSolv Hg 2610 additive used and calculate a 12-month rolling

SECTION E. Source Group Restrictions.

total.

[Authorization from RFD 10/04/2019]

020 [25 Pa. Code §139.101]**General requirements.**

In accordance with the Department's "Continuous Source Monitoring Manual", the permittee shall maintain the Continuous Emission Records as follows:

- 1) All data shall be reduced to one-hour averages on a clock basis. The reduction methods must be in accordance with the data validation and reduction criteria of the Department's Quality Assurance requirements.
- 2) A chronological file shall be maintained which includes the following:
 - a) All measurements from the systems;
 - b) All valid averages as specified above;
 - c) The cause, time periods, and magnitudes of all exceedances;
 - d) Data and results for all performance tests, audits, and recalibrations;
 - e) Records of any repairs, adjustments, or maintenance;
 - f) Conversion methods;
 - g) The cause and time periods for any invalid data;
 - h) Records of all corrective actions taken in response to exceedances;

Copies of the Phase I application, Phase II testing protocol, Phase III performance specification testing report, and all correspondence related to the CEMs.

[From Department's Continuous Source Monitoring Manual (Revision No. 8 {Current revision at time of permit issuance.}), Recordkeeping and Reporting Section, Subsections I.A.]

V. REPORTING REQUIREMENTS.**# 021 [25 Pa. Code §127.511]****Monitoring and related recordkeeping and reporting requirements.**

[Additional authority for permit condition (a) is also derived from 40 CFR §64.9 & §70.6 (a) (3) (iii) (A).]

The permittee shall report all excursions and corrective actions taken, the dates, times, durations and possible causes, every six (6) months.

022 [25 Pa. Code §135.4]**Report format**

In accordance with the Department's "Continuous Source Monitoring Manual," the owner or operator shall submit to the Department calendar quarterly reports of Continuous Emission Monitoring Systems (CEMs) data containing the following:

- 1) Information on the source and emissions in accordance with the appropriate reporting format approved by the Department.
- 2) The results of all performance tests, audits and recalibrations conducted during the quarter. The report certified by the responsible official shall be submitted to the Division of Source Testing and Monitoring, Continuous Testing Section within thirty (30) days following the end of each quarter in accordance with the Department's Continuous Source Monitoring Manual requirements.
- 3) Subsequent data report changes must be submitted in accordance with the Department's Continuous Source Monitoring Manual requirements.

[Additional authority for this permit condition is derived from 25 Pa. Code Sections 127.531 and 127.511.]

[From Department's Continuous Source Monitoring Manual (Revision No. 8), Recordkeeping and Reporting Section, Subsections I.B.]

**SECTION E. Source Group Restrictions.****VI. WORK PRACTICE REQUIREMENTS.****# 023 [25 Pa. Code §127.441]****Operating permit terms and conditions.**

The Owner/Operator shall act in conformance with the operation and maintenance (O&M) plan for the FGD systems.

[From Plan Approval, PA-03-00027B, Section E-Source Group 1 Condition 004.]

VII. ADDITIONAL REQUIREMENTS.**# 024 [25 Pa. Code §127.441]****Operating permit terms and conditions.**

In accordance with RACT Operating Permit No. 03-000-027, for the purpose of establishing NOx and Volatile Organic Compound (VOC) potential to emit (PTE) only, the following shall apply to sources at the facility:

Main Unit #1
70.17 tpy VOC
15,787.7 tpy NOx

Main Unit #2
70.17 tpy VOC
15,787.7 tpy NOx

025 [25 Pa. Code §127.441]**Operating permit terms and conditions.**

(a) If SO₂ emissions from the combined SO₂ Emitting Sources at the Keystone Plant exceed 99% of the SO₂ emission limit in Condition #009 above, Keystone shall, within 48 hours, undertake a full- system audit of the SO₂ Emitting Sources, and will submit a written report to DEP within 15 days. A malfunction report prepared pursuant to Title V Operating Permit 03-00027, Section B, Condition 031 shall satisfy this requirement. The full system audit shall consist of a review of the parameters routinely monitored by the Continuous Emissions Monitoring Systems and the Digital Data Acquisition Systems installed on the SO₂ Emitting Sources and their control devices to determine whether or not the units and control devices were operating in accordance with specifications set forth in the approved plan approval application and good air pollution control practices. If the SO₂ Emitting Sources and their control devices were not operating in accordance with specifications set forth in the approved plan approval application and good air pollution control practices, then Keystone shall identify corrective actions to be implemented to ensure that the limits in Condition #009, above, are not exceeded. Only one audit in a seven-operating day period is required if combined SO₂ emissions from the SO₂ Emitting Sources exceed 99% of the SO₂ emission limits in Condition #009, above. The audit and associated records shall be maintained on site.

(b) If the Strongstown monitor (AIRS ID 42-063-0004) measures a 1-hour concentration exceeding 75 ppb (which constitutes a daily exceedance of the 1-hour SO₂ NAAQS), the Department will notify Keystone both verbally and in writing. Keystone shall identify whether any of the SO₂ Emitting Sources at the Keystone Plant were running at the time of the exceedance, and/or within a reasonable time period leading up to the exceedance, not to exceed 24 hours. If any of the SO₂ Emitting Sources at the Keystone Plant were running at the time of the exceedance, and within a reasonable time-period leading up to the exceedance, not to exceed 24 hours, Keystone must then analyze the meteorological data on the day the daily exceedance occurred to ensure that the daily exceedance was not due to SO₂ emissions from the Keystone Plant. The meteorological data analysis should include trajectories run at three different heights (one at stack height and two more within the boundary layer) by the National Oceanic and Atmospheric Administration's Hysplit program or an equivalent program, and an analysis of Johnstown Airport's meteorological data and modeled upper air data using the National Weather Service's Butkit or equivalent program. The overall goal of the meteorological data analysis is to investigate if emissions from any of the Keystone Plant could have potentially mixed down to the Strongstown SO₂ monitor. Keystone's finding must be submitted in writing to the Department within 30 days of being notified of the exceedance. In lieu of performing this meteorological analysis for the Keystone Plant alone, meteorological analysis for Keystone and one or more of the power plants in the Indiana Nonattainment Area may be submitted, provided that the analysis is designed to investigate if emissions from the Keystone Plant could have potentially mixed down to the Strongstown SO₂ monitor.

[Authorization from Consent Order October 11, 2017]

026 [25 Pa. Code §127.531]**Special conditions related to acid rain.**

**SECTION E. Source Group Restrictions.**

(a) This section describes the permit program for acid deposition control in accordance with Titles IV and V of the Clean Air Act (42 U.S.C.A. 7641 and 7642 and 7661--7661f). The provisions of this section shall be interpreted in a manner consistent with the Clean Air Act and the regulations thereunder.

(b) The owner or operator or the designated representative of each affected source under section 405 of the Clean Air Act (42 U.S.C.A. 7651d) shall submit a permit application and compliance plan for the affected source to the Department within 120 days from notice by the Department to submit an application but no later than January 1, 1996, for sulfur dioxide, and no later than January 1, 1998, for NO_x, that meets the requirements of this chapter, the Clean Air Act and the regulations thereunder.

(c) In the case of affected sources for which an application and plan are timely received, the permit application and the compliance plan, including amendments thereto, shall be binding on the owner or operator or the designated representative of the owner or operator and shall be enforceable as a permit for purposes of this section until a permit is issued by the Department.

(d) A permit issued under this section shall require the source to achieve compliance as soon as possible but no later than the date required by the Clean Air Act or the regulations thereunder for the source.

(e) At any time after the submission of a permit application and compliance plan, the applicant may submit a revised application and compliance plan. In considering a permit application and compliance plan under this section, the Department will coordinate with the Pennsylvania Public Utility Commission consistent with the requirements established by the EPA.

(f) In addition to the other requirements of this chapter, permits issued under this section shall prohibit the following:

- (1) Annual emissions of sulfur dioxide in excess of the number of allowances to emit sulfur dioxide that the owner or operator or designated representative holds for the unit.
- (2) Exceeding applicable emission rates or standards, including ambient air quality standards.
- (3) The use of an allowance prior to the year for which it is allocated.
- (4) Contravention of other provisions of the permit.

(g) Each permit issued to a source under Title IV of the Clean Air Act shall contain a condition prohibiting emissions exceeding any allowances that the source lawfully holds under Title IV of the Clean Air Act or the regulations thereunder.

- (1) A permit revision will not be required for increases in emissions that are authorized by allowances acquired pursuant to the acid rain program, if the increases do not require a permit revision under another applicable requirement.
- (2) A limit will not be placed on the number of allowances held by the source. The source may not, however, use allowances as a defense to noncompliance with another applicable requirement.
- (3) An allowance shall be accounted for according to the procedures established in regulations promulgated under Title IV of the Clean Air Act.

027 [40 CFR Part 72 Regulations on Permits §40 CFR 72.1]**Subpart A--Acid Rain Program General Provisions****Purpose and scope.**

Boilers #1 and #2 (Source IDs 031 and 032) are subject to the Title IV Acid Rain Program of the 1990 Clean Air Act Amendments, and shall comply with all applicable provisions of that Title, including the following:

- 40 CFR Part 72 Permits Regulations
- 40 CFR Part 73 Sulfur Dioxide Allowance System
- 40 CFR Part 75 Continuous Emissions Monitoring
- 40 CFR Part 77 Excess Emissions

**SECTION E. Source Group Restrictions.**

The entire Title IV permit is attached to this Title V permit.

028 [40 CFR Part 72 Regulations on Permits §40 CFR 72.32]

Subpart C--Acid Rain Permit Application

Permit application shield and binding effect of permit application.

All subsections except (d).

029 [40 CFR Part 72 Regulations on Permits §40 CFR 72.51]

Subpart E--Acid Rain Permit Contents

Permit shield.

All subsections.

030 [40 CFR Part 72 Regulations on Permits §40 CFR 72.6]

Subpart A--Acid Rain Program General Provisions

Applicability.

Subsection (a) (2).

031 [40 CFR Part 75 Continuous Emission Monitoring §40 CFR 75.10]

Subpart B--Monitoring Provisions

General operating requirements.

All subsections.

032 [40 CFR Part 75 Continuous Emission Monitoring §40 CFR 75.12]

Subpart B--Monitoring Provisions

Specific provisions for monitoring NOx emissions (NOx and diluent gas monitors).

Subsections (a) and (b).

033 [40 CFR Part 75 Continuous Emission Monitoring §40 CFR 75.13]

Subpart B--Monitoring Provisions

Specific provisions for monitoring CO2 emissions.

Subsection (a).

034 [40 CFR Part 75 Continuous Emission Monitoring §40 CFR 75.14]

Subpart B--Monitoring Provisions

Specific provisions for monitoring opacity.

Subsections (a) and (b).

035 [40 CFR Part 75 Continuous Emission Monitoring §40 CFR 75.2]

Subpart A--General

Applicability.

All subsections.

036 [40 CFR Part 75 Continuous Emission Monitoring §40 CFR 75.20]

Subpart C--Operation and Maintenance Requirements

Certification and recertification procedures.

All subsections except (e), (f), and (g).

037 [40 CFR Part 75 Continuous Emission Monitoring §40 CFR 75.21]

Subpart C--Operation and Maintenance Requirements

Quality assurance and quality control requirements.

Subsections (a) (1), (2) and (3).

038 [40 CFR Part 75 Continuous Emission Monitoring §40 CFR 75.22]

Subpart C--Operation and Maintenance Requirements

Reference test methods.

All subsections.

039 [40 CFR Part 75 Continuous Emission Monitoring §40 CFR 75.24]

Subpart C--Operation and Maintenance Requirements

**SECTION E. Source Group Restrictions.****Out-of-control periods.**

All subsections.

040 [40 CFR Part 75 Continuous Emission Monitoring §40 CFR 75.30]**Subpart D--Missing Data Substitution Procedures****General provisions.**

All subsections.

041 [40 CFR Part 75 Continuous Emission Monitoring §40 CFR 75.4]**Subpart A--General****Compliance dates.**

Subsection (a) (3).

042 [40 CFR Part 75 Continuous Emission Monitoring §40 CFR 75.53]**Subpart F--Recordkeeping Requirements****Monitoring plan.**

All subsections.

043 [40 CFR Part 75 Continuous Emission Monitoring §40 CFR 75.60]**Subpart G--Reporting Requirements****General provisions.**

All subsections.

044 [40 CFR Part 75 Continuous Emission Monitoring §40 CFR 75.61]**Subpart G--Reporting Requirements****Notifications**

All subsections.

045 [40 CFR Part 75 Continuous Emission Monitoring §40 CFR 75.62]**Subpart G--Reporting Requirements****Monitoring plan.**

All subsections.

046 [40 CFR Part 75 Continuous Emission Monitoring §40 CFR 75.63]**Subpart G--Reporting Requirements****Initial certification or recertification application.**

All subsections.

047 [40 CFR Part 75 Continuous Emission Monitoring §40 CFR 75.64]**Subpart G--Reporting Requirements****Quarterly reports.**

All subsections.

***** Permit Shield in Effect. *****

**SECTION E. Source Group Restrictions.**

Group Name: G02

Group Description: Main Boilers #1 and #2 CSAPR

Sources included in this group

ID	Name
031	BOILER 1 WITH LOW NOX BURNER
032	BOILER 2 WITH LOW NOX BURNER

I. RESTRICTIONS.

No additional requirements exist except as provided in other sections of this permit including Section B (Title V General Requirements).

II. TESTING REQUIREMENTS.

No additional testing requirements exist except as provided in other sections of this permit including Section B (Title V General Requirements).

III. MONITORING REQUIREMENTS.

No additional monitoring requirements exist except as provided in other sections of this permit including Section B (Title V General Requirements).

IV. RECORDKEEPING REQUIREMENTS.

No additional record keeping requirements exist except as provided in other sections of this permit including Section B (Title V General Requirements).

V. REPORTING REQUIREMENTS.

No additional reporting requirements exist except as provided in other sections of this permit including Section B (Title V General Requirements).

VI. WORK PRACTICE REQUIREMENTS.

No additional work practice requirements exist except as provided in other sections of this permit including Section B (Title V General Requirements).

VII. ADDITIONAL REQUIREMENTS.**# 001 [25 Pa. Code §127.441]****Operating permit terms and conditions.**

The requirements of 25 Pa. Code §§ 145.204, 145.205, 145.212, 145.213, 145.222, 145.223 and the requirements of § 40 CFR 97.106, 97.206, and 97.306, which pertained to the CAIR requirements, were replaced by the CSAPR requirements and have been removed from this permit.

002 [40 CFR Part 97 NOx Budget Trading Program and CAIR NOx and SO2 Trading Programs §40 CFR 97.404]**Subpart AAAAA - CSAPR NOx Annual Trading Program****Applicability.**

(a) Boiler 1 (Source ID 031) and Boiler 2 (Source ID 032) are subject to the applicable requirements of 40 CFR Part 97, Subpart AAAAA - CSAPR NOx Annual Trading Program. As determined by 97.410 and adjusted on an annual basis by EPA, Boiler 1 (Source ID 031) and Boiler 2 (Source ID 032) are allocated the following CSAPR NOx Annual allowances for the years 2020 through 2024:

Year	NOx Annual Allocation (tons)	
	Boiler 1 (Source ID 031)	Boiler 2 (Source ID 032)
2020	6,166	6,085
2021	6,166	6,085
2022	6,166	6,085
2023	6,166	6,085
2024	6,166	6,085

SECTION E. Source Group Restrictions.

[Data allowances are available at EPA's Air Markets Program Data (<https://ampd.epa.gov/ampd/>).]

(b) In accordance with 40 CFR § § 97.421, EPA will announce in a notice of data availability and record in the Boiler 1 and Boiler 2 Annual NOx Compliance Account, the allowance allocations for control periods beyond the year 2024.

(c) The allowances in subsection (a) of this condition are subject to change. Any changes will be promulgated by US EPA in a notice of data availability. Upon promulgation, the new allowances replace the amounts in subsection (a) by rule.

**# 003 [40 CFR Part 97 NOx Budget Trading Program and CAIR NOx and SO2 Trading Programs §40 CFR 97.406]
Subpart AAAAA - CSAPR NOX Annual Trading Program
Standard requirements.**

(a) DESIGNATED REPRESENTATIVE REQUIREMENTS. The owners and operators shall comply with the requirement to have a designated representative, and may have an alternate designated representative, in accordance with §§97.413 through 97.418.

(b) EMISSIONS MONITORING, REPORTING, AND RECORDKEEPING REQUIREMENTS.

(1) The owners and operators, and the designated representative, of each CSAPR NOX Annual source and each CSAPR NOX Annual unit at the source shall comply with the monitoring, reporting, and recordkeeping requirements of §§97.430 through 97.435.

(2) The emissions data determined in accordance with §§97.430 through 97.435 shall be used to calculate allocations of CSAPR NOX Annual allowances under §§97.411(a)(2) and (b) and 97.412 and to determine compliance with the CSAPR NOX Annual emissions limitation and assurance provisions under paragraph (c) of this section, provided that, for each monitoring location from which mass emissions are reported, the mass emissions amount used in calculating such allocations and determining such compliance shall be the mass emissions amount for the monitoring location determined in accordance with §§97.430 through 97.435 and rounded to the nearest ton, with any fraction of a ton less than 0.50 being deemed to be zero.

(c) NOX EMISSIONS REQUIREMENTS.

(1) CSAPR NOX ANNUAL EMISSIONS LIMITATION.

(i) As of the allowance transfer deadline for a control period in a given year, the owners and operators of each CSAPR NOX Annual source and each CSAPR NOX Annual unit at the source shall hold, in the source's compliance account, CSAPR NOX Annual allowances available for deduction for such control period under §97.424(a) in an amount not less than the tons of total NOX emissions for such control period from all CSAPR NOX Annual units at the source.

(ii) If total NOX emissions during a control period in a given year from the CSAPR NOX Annual units at a CSAPR NOX Annual source are in excess of the CSAPR NOX Annual emissions limitation set forth in paragraph (c)(1)(i) of this section, then:

(A) The owners and operators of the source and each CSAPR NOX Annual unit at the source shall hold the CSAPR NOX Annual allowances required for deduction under §97.424(d); and

(B) The owners and operators of the source and each CSAPR NOX Annual unit at the source shall pay any fine, penalty, or assessment or comply with any other remedy imposed, for the same violations, under the Clean Air Act, and each ton of such excess emissions and each day of such control period shall constitute a separate violation of this subpart and the Clean Air Act.

(2) CSAPR NOX ANNUAL ASSURANCE PROVISIONS.

(i) If total NOX emissions during a control period in a given year from all CSAPR NOX Annual units at CSAPR NOX Annual sources in a State (and Indian country within the borders of such State) exceed the State assurance level, then the owners and operators of such sources and units in each group of one or more sources and units having a common designated representative for such control period, where the common designated representative's share of such NOX emissions during such control period exceeds the common designated representative's assurance level for the State and such control

**SECTION E. Source Group Restrictions.**

period, shall hold (in the assurance account established for the owners and operators of such group) CSAPR NOX Annual allowances available for deduction for such control period under §97.425(a) in an amount equal to two times the product (rounded to the nearest whole number), as determined by the Administrator in accordance with §97.425(b), of multiplying—

(A) The quotient of the amount by which the common designated representative's share of such NOX emissions exceeds the common designated representative's assurance level divided by the sum of the amounts, determined for all common designated representatives for such sources and units in the State (and Indian country within the borders of such State) for such control period, by which each common designated representative's share of such NOX emissions exceeds the respective common designated representative's assurance level; and

(B) The amount by which total NOX emissions from all CSAPR NOX Annual units at CSAPR NOX Annual sources in the State (and Indian country within the borders of such State) for such control period exceed the State assurance level.

(ii) The owners and operators shall hold the CSAPR NOX Annual allowances required under paragraph (c)(2)(i) of this section, as of midnight of November 1 (if it is a business day), or midnight of the first business day thereafter (if November 1 is not a business day), immediately after the year of such control period.

(iii) Total NOX emissions from all CSAPR NOX Annual units at CSAPR NOX Annual sources in a State (and Indian country within the borders of such State) during a control period in a given year exceed the State assurance level if such total NOX emissions exceed the sum, for such control period, of the State NOX Annual trading budget under §97.410(a) and the State's variability limit under §97.410(b).

(iv) It shall not be a violation of this subpart or of the Clean Air Act if total NOX emissions from all CSAPR NOX Annual units at CSAPR NOX Annual sources in a State (and Indian country within the borders of such State) during a control period exceed the State assurance level or if a common designated representative's share of total NOX emissions from the CSAPR NOX Annual units at CSAPR NOX Annual sources in a State (and Indian country within the borders of such State) during a control period exceeds the common designated representative's assurance level.

(v) To the extent the owners and operators fail to hold CSAPR NOX Annual allowances for a control period in a given year in accordance with paragraphs (c)(2)(i) through (iii) of this section,

(A) The owners and operators shall pay any fine, penalty, or assessment or comply with any other remedy imposed under the Clean Air Act; and

(B) Each CSAPR NOX Annual allowance that the owners and operators fail to hold for such control period in accordance with paragraphs (c)(2)(i) through (iii) of this section and each day of such control period shall constitute a separate violation of this subpart and the Clean Air Act.

(3) COMPLIANCE PERIODS.

(i) A CSAPR NOX Annual unit shall be subject to the requirements under paragraph (c)(1) of this section for the control period starting on the later of January 1, 2015 or the deadline for meeting the unit's monitor certification requirements under §97.430(b) and for each control period thereafter.

(ii) A CSAPR NOX Annual unit shall be subject to the requirements under paragraph (c)(2) of this section for the control period starting on the later of January 1, 2017 or the deadline for meeting the unit's monitor certification requirements under §97.430(b) and for each control period thereafter.

(4) VINTAGE OF CSAPR NOX ANNUAL ALLOWANCES HELD FOR COMPLIANCE.

(i) A CSAPR NOX Annual allowance held for compliance with the requirements under paragraph (c)(1)(i) of this section for a control period in a given year must be a CSAPR NOX Annual allowance that was allocated or auctioned for such control period or a control period in a prior year.

(ii) A CSAPR NOX Annual allowance held for compliance with the requirements under paragraphs (c)(1)(ii)(A) and (2)(i) through (iii) of this section for a control period in a given year must be a CSAPR NOX Annual allowance that was allocated or auctioned for a control period in a prior year or the control period in the given year or in the immediately following year.

**SECTION E. Source Group Restrictions.**

(5) ALLOWANCE MANAGEMENT SYSTEM REQUIREMENTS. Each CSAPR NOX Annual allowance shall be held in, deducted from, or transferred into, out of, or between Allowance Management System accounts in accordance with this subpart.

(6) LIMITED AUTHORIZATION. A CSAPR NOX Annual allowance is a limited authorization to emit one ton of NOX during the control period in one year. Such authorization is limited in its use and duration as follows:

(i) Such authorization shall only be used in accordance with the CSAPR NOX Annual Trading Program; and

(ii) Notwithstanding any other provision of this subpart, the Administrator has the authority to terminate or limit the use and duration of such authorization to the extent the Administrator determines is necessary or appropriate to implement any provision of the Clean Air Act.

(7) PROPERTY RIGHT. A CSAPR NOX Annual allowance does not constitute a property right.

(d) TITLE V PERMIT REQUIREMENTS.

(1) No title V permit revision shall be required for any allocation, holding, deduction, or transfer of CSAPR NOX Annual allowances in accordance with this subpart.

(2) A description of whether a unit is required to monitor and report NOX emissions using a continuous emission monitoring system (under subpart H of part 75 of this chapter), an excepted monitoring system (under appendices D and E to part 75 of this chapter), a low mass emissions excepted monitoring methodology (under §75.19 of this chapter), or an alternative monitoring system (under subpart E of part 75 of this chapter) in accordance with §§97.430 through 97.435 may be added to, or changed in, a title V permit using minor permit modification procedures in accordance with §§70.7(e)(2) and 71.7(e)(1) of this chapter, provided that the requirements applicable to the described monitoring and reporting (as added or changed, respectively) are already incorporated in such permit. This paragraph explicitly provides that the addition of, or change to, a unit's description as described in the prior sentence is eligible for minor permit modification procedures in accordance with §§70.7(e)(2)(i)(B) and 71.7(e)(1)(i)(B) of this chapter.

(e) ADDITIONAL RECORDKEEPING AND REPORTING REQUIREMENTS.

(1) Unless otherwise provided, the owners and operators of each CSAPR NOX Annual source and each CSAPR NOX Annual unit at the source shall keep on site at the source each of the following documents (in hardcopy or electronic format) for a period of 5 years from the date the document is created. This period may be extended for cause, at any time before the end of 5 years, in writing by the Administrator.

(i) The certificate of representation under §97.416 for the designated representative for the source and each CSAPR NOX Annual unit at the source and all documents that demonstrate the truth of the statements in the certificate of representation; provided that the certificate and documents shall be retained on site at the source beyond such 5-year period until such certificate of representation and documents are superseded because of the submission of a new certificate of representation under §97.416 changing the designated representative.

(ii) All emissions monitoring information, in accordance with this subpart.

(iii) Copies of all reports, compliance certifications, and other submissions and all records made or required under, or to demonstrate compliance with the requirements of, the CSAPR NOX Annual Trading Program.

(2) The designated representative of a CSAPR NOX Annual source and each CSAPR NOX Annual unit at the source shall make all submissions required under the CSAPR NOX Annual Trading Program, except as provided in §97.418. This requirement does not change, create an exemption from, or otherwise affect the responsible official submission requirements under a title V operating permit program in parts 70 and 71 of this chapter.

(f) LIABILITY.

(1) Any provision of the CSAPR NOX Annual Trading Program that applies to a CSAPR NOX Annual source or the designated representative of a CSAPR NOX Annual source shall also apply to the owners and operators of such source

**SECTION E. Source Group Restrictions.**

and of the CSAPR NOX Annual units at the source.

(2) Any provision of the CSAPR NOX Annual Trading Program that applies to a CSAPR NOX Annual unit or the designated representative of a CSAPR NOX Annual unit shall also apply to the owners and operators of such unit.

(g) EFFECT ON OTHER AUTHORITIES. No provision of the CSAPR NOX Annual Trading Program or exemption under §97.405 shall be construed as exempting or excluding the owners and operators, and the designated representative, of a CSAPR NOX Annual source or CSAPR NOX Annual unit from compliance with any other provision of the applicable, approved State implementation plan, a federally enforceable permit, or the Clean Air Act.

[76 FR 48379, Aug. 8, 2011, as amended at 77 FR 10334, Feb. 21, 2012; 79 FR 71672, Dec. 3, 2014; 81 FR 74606, Oct. 26, 2016]

004 [40 CFR Part 97 NOx Budget Trading Program and CAIR NOx and SO2 Trading Programs §40 CFR 97.430]

Subpart AAAAA - CSAPR NOX Annual Trading Program

General monitoring, recordkeeping, and reporting requirements.

The owners and operators, and to the extent applicable, the designated representative, of a CSAPR NOX Annual unit, shall comply with the monitoring, recordkeeping, and reporting requirements as provided in this subpart and subpart H of part 75 of this chapter. For purposes of applying such requirements, the definitions in §97.402 and in §72.2 of this chapter shall apply, the terms "affected unit," "designated representative," and "continuous emission monitoring system" (or "CEMS") in part 75 of this chapter shall be deemed to refer to the terms "CSAPR NOX Annual unit," "designated representative," and "continuous emission monitoring system" (or "CEMS") respectively as defined in §97.402, and the term "newly affected unit" shall be deemed to mean "newly affected CSAPR NOX Annual unit". The owner or operator of a unit that is not a CSAPR NOX Annual unit but that is monitored under §75.72(b)(2)(ii) of this chapter shall comply with the same monitoring, recordkeeping, and reporting requirements as a CSAPR NOX Annual unit.

(a) REQUIREMENTS FOR INSTALLATION, CERTIFICATION, AND DATA ACCOUNTING. The owner or operator of each CSAPR NOX Annual unit shall:

(1) Install all monitoring systems required under this subpart for monitoring NOX mass emissions and individual unit heat input (including all systems required to monitor NOX emission rate, NOX concentration, stack gas moisture content, stack gas flow rate, CO2 or O2 concentration, and fuel flow rate, as applicable, in accordance with §§75.71 and 75.72 of this chapter);

(2) Successfully complete all certification tests required under §97.431 and meet all other requirements of this subpart and part 75 of this chapter applicable to the monitoring systems under paragraph (a)(1) of this section; and

(3) Record, report, and quality-assure the data from the monitoring systems under paragraph (a)(1) of this section.

(b) COMPLIANCE DEADLINES. Except as provided in paragraph (e) of this section, the owner or operator of a CSAPR NOX Annual unit shall meet the monitoring system certification and other requirements of paragraphs (a)(1) and (2) of this section on or before the later of the following dates and shall record, report, and quality-assure the data from the monitoring systems under paragraph (a)(1) of this section on and after the later of the following dates:

(1) January 1, 2015; or

(2) 180 calendar days after the date on which the unit commences commercial operation.

(3) The owner or operator of a CSAPR NOX Annual unit for which construction of a new stack or flue or installation of add-on NOX emission controls is completed after the applicable deadline under paragraph (b)(1) or (2) of this section shall meet the requirements of §75.4(e)(1) through (4) of this chapter, except that:

(i) Such requirements shall apply to the monitoring systems required under §97.430 through §97.435, rather than the monitoring systems required under part 75 of this chapter;

(ii) NOX emission rate, NOX concentration, stack gas moisture content, stack gas volumetric flow rate, and O2 or CO2 concentration data shall be determined and reported, rather than the data listed in §75.4(e)(2) of this chapter; and

**SECTION E. Source Group Restrictions.**

(iii) Any petition for another procedure under §75.4(e)(2) of this chapter shall be submitted under §97.435, rather than §75.66 of this chapter.

(c) REPORTING DATA. The owner or operator of a CSAPR NOX Annual unit that does not meet the applicable compliance date set forth in paragraph (b) of this section for any monitoring system under paragraph (a)(1) of this section shall, for each such monitoring system, determine, record, and report maximum potential (or, as appropriate, minimum potential) values for NOX concentration, NOX emission rate, stack gas flow rate, stack gas moisture content, fuel flow rate, and any other parameters required to determine NOX mass emissions and heat input in accordance with §75.31(b)(2) or (c)(3) of this chapter, section 2.4 of appendix D to part 75 of this chapter, or section 2.5 of appendix E to part 75 of this chapter, as applicable.

(d) PROHIBITIONS.

(1) No owner or operator of a CSAPR NOX Annual unit shall use any alternative monitoring system, alternative reference method, or any other alternative to any requirement of this subpart without having obtained prior written approval in accordance with §97.435.

(2) No owner or operator of a CSAPR NOX Annual unit shall operate the unit so as to discharge, or allow to be discharged, NOX to the atmosphere without accounting for all such NOX in accordance with the applicable provisions of this subpart and part 75 of this chapter.

(3) No owner or operator of a CSAPR NOX Annual unit shall disrupt the continuous emission monitoring system, any portion thereof, or any other approved emission monitoring method, and thereby avoid monitoring and recording NOX mass discharged into the atmosphere or heat input, except for periods of recertification or periods when calibration, quality assurance testing, or maintenance is performed in accordance with the applicable provisions of this subpart and part 75 of this chapter.

(4) No owner or operator of a CSAPR NOX Annual unit shall retire or permanently discontinue use of the continuous emission monitoring system, any component thereof, or any other approved monitoring system under this subpart, except under any one of the following circumstances:

(i) During the period that the unit is covered by an exemption under §97.405 that is in effect;

(ii) The owner or operator is monitoring emissions from the unit with another certified monitoring system approved, in accordance with the applicable provisions of this subpart and part 75 of this chapter, by the Administrator for use at that unit that provides emission data for the same pollutant or parameter as the retired or discontinued monitoring system; or

(iii) The designated representative submits notification of the date of certification testing of a replacement monitoring system for the retired or discontinued monitoring system in accordance with §97.431(d)(3)(i).

(e) LONG-TERM COLD STORAGE. The owner or operator of a CSAPR NOX Annual unit is subject to the applicable provisions of §75.4(d) of this chapter concerning units in long-term cold storage.

[76 FR 48379, Aug. 8, 2011, as amended at 79 FR 71672, Dec. 3, 2014; 81 FR 74607, Oct. 26, 2016]

005 [40 CFR Part 97 NOx Budget Trading Program and CAIR NOx and SO2 Trading Programs §40 CFR 97.434]

Subpart AAAAA - CSAPR NOX Annual Trading Program

Recordkeeping and reporting.

(a) GENERAL PROVISIONS. The designated representative shall comply with all recordkeeping and reporting requirements in paragraphs (b) through (e) of this section, the applicable recordkeeping and reporting requirements under §75.73 of this chapter, and the requirements of §97.414(a).

(b) MONITORING PLANS. The owner or operator of a CSAPR NOX Annual unit shall comply with the requirements of §75.73(c) and (e) of this chapter.

(c) CERTIFICATION APPLICATIONS. The designated representative shall submit an application to the Administrator within 45 days after completing all initial certification or recertification tests required under §97.431, including the information

**SECTION E. Source Group Restrictions.**

required under §75.63 of this chapter.

(d) **QUARTERLY REPORTS.** The designated representative shall submit quarterly reports, as follows:

(1) The designated representative shall report the NOX mass emissions data and heat input data for a CSAPR NOX Annual unit, in an electronic quarterly report in a format prescribed by the Administrator, for each calendar quarter beginning with the later of:

- (i) The calendar quarter covering January 1, 2015 through March 31, 2015; or
- (ii) The calendar quarter corresponding to the earlier of the date of provisional certification or the applicable deadline for initial certification under §97.430(b).

(2) The designated representative shall submit each quarterly report to the Administrator within 30 days after the end of the calendar quarter covered by the report. Quarterly reports shall be submitted in the manner specified in §75.73(f) of this chapter.

(3) For CSAPR NOX Annual units that are also subject to the Acid Rain Program, CSAPR NOX Ozone Season Group 1 Trading Program, CSAPR NOX Ozone Season Group 2 Trading Program, CSAPR SO2 Group 1 Trading Program, or CSAPR SO2 Group 2 Trading Program, quarterly reports shall include the applicable data and information required by subparts F through H of part 75 of this chapter as applicable, in addition to the NOX mass emission data, heat input data, and other information required by this subpart.

(4) The Administrator may review and conduct independent audits of any quarterly report in order to determine whether the quarterly report meets the requirements of this subpart and part 75 of this chapter, including the requirement to use substitute data.

(i) The Administrator will notify the designated representative of any determination that the quarterly report fails to meet any such requirements and specify in such notification any corrections that the Administrator believes are necessary to make through resubmission of the quarterly report and a reasonable time period within which the designated representative must respond. Upon request by the designated representative, the Administrator may specify reasonable extensions of such time period. Within the time period (including any such extensions) specified by the Administrator, the designated representative shall resubmit the quarterly report with the corrections specified by the Administrator, except to the extent the designated representative provides information demonstrating that a specified correction is not necessary because the quarterly report already meets the requirements of this subpart and part 75 of this chapter that are relevant to the specified correction.

(ii) Any resubmission of a quarterly report shall meet the requirements applicable to the submission of a quarterly report under this subpart and part 75 of this chapter, except for the deadline set forth in paragraph (d)(2) of this section.

(e) **COMPLIANCE CERTIFICATION.** The designated representative shall submit to the Administrator a compliance certification (in a format prescribed by the Administrator) in support of each quarterly report based on reasonable inquiry of those persons with primary responsibility for ensuring that all of the unit's emissions are correctly and fully monitored. The certification shall state that:

(1) The monitoring data submitted were recorded in accordance with the applicable requirements of this subpart and part 75 of this chapter, including the quality assurance procedures and specifications; and

(2) For a unit with add-on NOX emission controls and for all hours where NOX data are substituted in accordance with §75.34(a)(1) of this chapter, the add-on emission controls were operating within the range of parameters listed in the quality assurance/quality control program under appendix B to part 75 of this chapter and the substitute data values do not systematically underestimate NOX emissions.

[76 FR 48379, Aug. 8, 2011, as amended at 79 FR 71672, Dec. 3, 2014; 81 FR 74607, Oct. 26, 2016]

006 [40 CFR Part 97 NOx Budget Trading Program and CAIR NOx and SO2 Trading Programs §40 CFR 97.604]
Subpart CCCCC - CSAPR SO2 Group 1 Trading Program
Applicability.

(a) Boiler 1 (Source ID 031) and Boiler 2 (Source ID 032) are subject to the applicable requirements of 40 CFR Part 97,

**SECTION E. Source Group Restrictions.**

Subpart CCCCC - CSAPR SO2 Group 1 Trading Program. As determined by 97.610 and adjusted on an annual basis by EPA, Boiler 1 (Source ID 031) and Boiler 2 (Source ID 032) are allocated the following CSAPR SO2 Group 1 allowances for the years 2020 through 2024:

Year	SO2 Group 1 Annual Allocation (tons)	
	Boiler 1 (Source ID 031)	Boiler 2 (Source ID 032)
2020	5,855	5,778
2021	5,855	5,778
2022	5,855	5,778
2023	5,855	5,778
2024	5,855	5,778

[Data allowances are available at EPA's Air Markets Program Data (<https://ampd.epa.gov/ampd/>).]

(b) In accordance with 40 CFR § 97.621, EPA will announce in a notice of data availability and record in the Boiler 1 and Boiler 2 Annual SO2 Group 1 Compliance Account, the allowance allocations for control periods beyond the year 2024.

(c) The allowances in subsection (a) of this condition are subject to change. Any changes will be promulgated by US EPA in a notice of data availability. Upon promulgation, the new allowances replace the amounts in subsection (a) by rule.

007 [40 CFR Part 97 NOx Budget Trading Program and CAIR NOx and SO2 Trading Programs §40 CFR 97.606]
Subpart CCCCC - CSAPR SO2 Group 1 Trading Program
Standard requirements.

(a) DESIGNATED REPRESENTATIVE REQUIREMENTS. The owners and operators shall comply with the requirement to have a designated representative, and may have an alternate designated representative, in accordance with §§97.613 through 97.618.

(b) EMISSIONS MONITORING, REPORTING, AND RECORDKEEPING REQUIREMENTS.

(1) The owners and operators, and the designated representative, of each CSAPR SO2 Group 1 source and each CSAPR SO2 Group 1 unit at the source shall comply with the monitoring, reporting, and recordkeeping requirements of §§97.630 through 97.635.

(2) The emissions data determined in accordance with §§97.630 through 97.635 shall be used to calculate allocations of CSAPR SO2 Group 1 allowances under §§97.611(a)(2) and (b) and 97.612 and to determine compliance with the CSAPR SO2 Group 1 emissions limitation and assurance provisions under paragraph (c) of this section, provided that, for each monitoring location from which mass emissions are reported, the mass emissions amount used in calculating such allocations and determining such compliance shall be the mass emissions amount for the monitoring location determined in accordance with §§97.630 through 97.635 and rounded to the nearest ton, with any fraction of a ton less than 0.50 being deemed to be zero.

(c) SO2 EMISSIONS REQUIREMENTS.

(1) CSAPR SO2 GROUP 1 EMISSION LIMITATION.

(i) As of the allowance transfer deadline for a control period in a given year, the owners and operators of each CSAPR SO2 Group 1 source and each CSAPR SO2 Group 1 unit at the source shall hold, in the source's compliance account, CSAPR SO2 Group 1 allowances available for deduction for such control period under §97.624(a) in an amount not less than the tons of total SO2 emissions for such control period from all CSAPR SO2 Group 1 units at the source.

(ii) If total SO2 emissions during a control period in a given year from the CSAPR SO2 Group 1 units at a CSAPR SO2 Group 1 source are in excess of the CSAPR SO2 Group 1 emissions limitation set forth in paragraph (c)(1)(i) of this section, then:

(A) The owners and operators of the source and each CSAPR SO2 Group 1 unit at the source shall hold the CSAPR SO2 Group 1 allowances required for deduction under §97.624(d); and

**SECTION E. Source Group Restrictions.**

(B) The owners and operators of the source and each CSAPR SO₂ Group 1 unit at the source shall pay any fine, penalty, or assessment or comply with any other remedy imposed, for the same violations, under the Clean Air Act, and each ton of such excess emissions and each day of such control period shall constitute a separate violation of this subpart and the Clean Air Act.

(2) CSAPR SO₂ GROUP 1 ASSURANCE PROVISIONS.

(i) If total SO₂ emissions during a control period in a given year from all CSAPR SO₂ Group 1 units at CSAPR SO₂ Group 1 sources in a State (and Indian country within the borders of such State) exceed the State assurance level, then the owners and operators of such sources and units in each group of one or more sources and units having a common designated representative for such control period, where the common designated representative's share of such SO₂ emissions during such control period exceeds the common designated representative's assurance level for the State and such control period, shall hold (in the assurance account established for the owners and operators of such group) CSAPR SO₂ Group 1 allowances available for deduction for such control period under §97.625(a) in an amount equal to two times the product (rounded to the nearest whole number), as determined by the Administrator in accordance with §97.625(b), of multiplying—

(A) The quotient of the amount by which the common designated representative's share of such SO₂ emissions exceeds the common designated representative's assurance level divided by the sum of the amounts, determined for all common designated representatives for such sources and units in the State (and Indian country within the borders of such State) for such control period, by which each common designated representative's share of such SO₂ emissions exceeds the respective common designated representative's assurance level; and

(B) The amount by which total SO₂ emissions from all CSAPR SO₂ Group 1 units at CSAPR SO₂ Group 1 sources in the State (and Indian country within the borders of such State) for such control period exceed the State assurance level.

(ii) The owners and operators shall hold the CSAPR SO₂ Group 1 allowances required under paragraph (c)(2)(i) of this section, as of midnight of November 1 (if it is a business day), or midnight of the first business day thereafter (if November 1 is not a business day), immediately after the year of such control period.

(iii) Total SO₂ emissions from all CSAPR SO₂ Group 1 units at CSAPR SO₂ Group 1 sources in a State (and Indian country within the borders of such State) during a control period in a given year exceed the State assurance level if such total SO₂ emissions exceed the sum, for such control period, of the State SO₂ Group 1 trading budget under §97.610(a) and the State's variability limit under §97.610(b).

(iv) It shall not be a violation of this subpart or of the Clean Air Act if total SO₂ emissions from all CSAPR SO₂ Group 1 units at CSAPR SO₂ Group 1 sources in a State (and Indian country within the borders of such State) during a control period exceed the State assurance level or if a common designated representative's share of total SO₂ emissions from the CSAPR SO₂ Group 1 units at CSAPR SO₂ Group 1 sources in a State (and Indian country within the borders of such State) during a control period exceeds the common designated representative's assurance level.

(v) To the extent the owners and operators fail to hold CSAPR SO₂ Group 1 allowances for a control period in a given year in accordance with paragraphs (c)(2)(i) through (iii) of this section,

(A) The owners and operators shall pay any fine, penalty, or assessment or comply with any other remedy imposed under the Clean Air Act; and (B) Each CSAPR SO₂ Group 1 allowance that the owners and operators fail to hold for such control period in accordance with paragraphs (c)(2)(i) through (iii) of this section and each day of such control period shall constitute a separate violation of this subpart and the Clean Air Act.

(3) COMPLIANCE PERIODS.

(i) A CSAPR SO₂ Group 1 unit shall be subject to the requirements under paragraph (c)(1) of this section for the control period starting on the later of January 1, 2015 or the deadline for meeting the unit's monitor certification requirements under §97.630(b) and for each control period thereafter.

(ii) A CSAPR SO₂ Group 1 unit shall be subject to the requirements under paragraph (c)(2) of this section for the control period starting on the later of January 1, 2017 or the deadline for meeting the unit's monitor certification requirements under §97.630(b) and for each control period thereafter.

**SECTION E. Source Group Restrictions.****(4) VINTAGE OF CSAPR SO₂ GROUP 1 ALLOWANCES HELD FOR COMPLIANCE.**

(i) A CSAPR SO₂ Group 1 allowance held for compliance with the requirements under paragraph (c)(1)(i) of this section for a control period in a given year must be a CSAPR SO₂ Group 1 allowance that was allocated or auctioned for such control period or a control period in a prior year.

(ii) A CSAPR SO₂ Group 1 allowance held for compliance with the requirements under paragraphs (c)(1)(ii)(A) and (2)(i) through (iii) of this section for a control period in a given year must be a CSAPR SO₂ Group 1 allowance that was allocated or auctioned for a control period in a prior year or the control period in the given year or in the immediately following year.

(5) ALLOWANCE MANAGEMENT SYSTEM REQUIREMENTS. Each CSAPR SO₂ Group 1 allowance shall be held in, deducted from, or transferred into, out of, or between Allowance Management System accounts in accordance with this subpart.

(6) LIMITED AUTHORIZATION. A CSAPR SO₂ Group 1 allowance is a limited authorization to emit one ton of SO₂ during the control period in one year. Such authorization is limited in its use and duration as follows:

(i) Such authorization shall only be used in accordance with the CSAPR SO₂ Group 1 Trading Program; and

(ii) Notwithstanding any other provision of this subpart, the Administrator has the authority to terminate or limit the use and duration of such authorization to the extent the Administrator determines is necessary or appropriate to implement any provision of the Clean Air Act.

(7) PROPERTY RIGHT. A CSAPR SO₂ Group 1 allowance does not constitute a property right.

(d) TITLE V PERMIT REQUIREMENTS.

(1) No title V permit revision shall be required for any allocation, holding, deduction, or transfer of CSAPR SO₂ Group 1 allowances in accordance with this subpart.

(2) A description of whether a unit is required to monitor and report SO₂ emissions using a continuous emission monitoring system (under subpart B of part 75 of this chapter), an excepted monitoring system (under appendices D and E to part 75 of this chapter), a low mass emissions excepted monitoring methodology (under §75.19 of this chapter), or an alternative monitoring system (under subpart E of part 75 of this chapter) in accordance with §§97.630 through 97.635 may be added to, or changed in, a title V permit using minor permit modification procedures in accordance with §§70.7(e)(2) and 71.7(e)(1) of this chapter, provided that the requirements applicable to the described monitoring and reporting (as added or changed, respectively) are already incorporated in such permit. This paragraph explicitly provides that the addition of, or change to, a unit's description as described in the prior sentence is eligible for minor permit modification procedures in accordance with §§70.7(e)(2)(i)(B) and 71.7(e)(1)(i)(B) of this chapter.

(e) ADDITIONAL RECORDKEEPING AND REPORTING REQUIREMENTS.

(1) Unless otherwise provided, the owners and operators of each CSAPR SO₂ Group 1 source and each CSAPR SO₂ Group 1 unit at the source shall keep on site at the source each of the following documents (in hardcopy or electronic format) for a period of 5 years from the date the document is created. This period may be extended for cause, at any time before the end of 5 years, in writing by the Administrator.

(i) The certificate of representation under §97.616 for the designated representative for the source and each CSAPR SO₂ Group 1 unit at the source and all documents that demonstrate the truth of the statements in the certificate of representation; provided that the certificate and documents shall be retained on site at the source beyond such 5-year period until such certificate of representation and documents are superseded because of the submission of a new certificate of representation under §97.616 changing the designated representative.

(ii) All emissions monitoring information, in accordance with this subpart.

(iii) Copies of all reports, compliance certifications, and other submissions and all records made or required under, or to demonstrate compliance with the requirements of, the CSAPR SO₂ Group 1 Trading Program.

**SECTION E. Source Group Restrictions.**

(2) The designated representative of a CSAPR SO₂ Group 1 source and each CSAPR SO₂ Group 1 unit at the source shall make all submissions required under the CSAPR SO₂ Group 1 Trading Program, except as provided in §97.618. This requirement does not change, create an exemption from, or otherwise affect the responsible official submission requirements under a title V operating permit program in parts 70 and 71 of this chapter.

(f) LIABILITY.

(1) Any provision of the CSAPR SO₂ Group 1 Trading Program that applies to a CSAPR SO₂ Group 1 source or the designated representative of a CSAPR SO₂ Group 1 source shall also apply to the owners and operators of such source and of the CSAPR SO₂ Group 1 units at the source.

(2) Any provision of the CSAPR SO₂ Group 1 Trading Program that applies to a CSAPR SO₂ Group 1 unit or the designated representative of a CSAPR SO₂ Group 1 unit shall also apply to the owners and operators of such unit.

(g) EFFECT ON OTHER AUTHORITIES. No provision of the CSAPR SO₂ Group 1 Trading Program or exemption under §97.605 shall be construed as exempting or excluding the owners and operators, and the designated representative, of a CSAPR SO₂ Group 1 source or CSAPR SO₂ Group 1 unit from compliance with any other provision of the applicable, approved State implementation plan, a federally enforceable permit, or the Clean Air Act.

[76 FR 48432, Aug. 8, 2011, as amended at 77 FR 10338, Feb. 21, 2012; 79 FR 71672, Dec. 3, 2014; 81 FR 74616, Aug. 8, 2011.]

008 [40 CFR Part 97 NO_x Budget Trading Program and CAIR NO_x and SO₂ Trading Programs §40 CFR 97.630]
Subpart CCCCC - CSAPR SO₂ Group 1 Trading Program
General monitoring, recordkeeping, and reporting requirements.

The owners and operators, and to the extent applicable, the designated representative, of a CSAPR SO₂ Group 1 unit, shall comply with the monitoring, recordkeeping, and reporting requirements as provided in this subpart and subparts F and G of part 75 of this chapter. For purposes of applying such requirements, the definitions in §97.602 and in §72.2 of this chapter shall apply, the terms "affected unit," "designated representative," and "continuous emission monitoring system" (or "CEMS") in part 75 of this chapter shall be deemed to refer to the terms "CSAPR SO₂ Group 1 unit," "designated representative," and "continuous emission monitoring system" (or "CEMS") respectively as defined in §97.602, and the term "newly affected unit" shall be deemed to mean "newly affected CSAPR SO₂ Group 1 unit". The owner or operator of a unit that is not a CSAPR SO₂ Group 1 unit but that is monitored under §75.16(b)(2) of this chapter shall comply with the same monitoring, recordkeeping, and reporting requirements as a CSAPR SO₂ Group 1 unit.

(a) REQUIREMENTS FOR INSTALLATION, CERTIFICATION, AND DATA ACCOUNTING. The owner or operator of each CSAPR SO₂ Group 1 unit shall:

(1) Install all monitoring systems required under this subpart for monitoring SO₂ mass emissions and individual unit heat input (including all systems required to monitor SO₂ concentration, stack gas moisture content, stack gas flow rate, CO₂ or O₂ concentration, and fuel flow rate, as applicable, in accordance with §§75.11 and 75.16 of this chapter);

(2) Successfully complete all certification tests required under §97.631 and meet all other requirements of this subpart and part 75 of this chapter applicable to the monitoring systems under paragraph (a)(1) of this section; and

(3) Record, report, and quality-assure the data from the monitoring systems under paragraph (a)(1) of this section.

(b) COMPLIANCE DEADLINES. Except as provided in paragraph (e) of this section, the owner or operator of a CSAPR SO₂ Group 1 unit shall meet the monitoring system certification and other requirements of paragraphs (a)(1) and (2) of this section on or before the later of the following dates and shall record, report, and quality-assure the data from the monitoring systems under paragraph (a)(1) of this section on and after the later of the following dates:

(1) January 1, 2015; or

(2) 180 calendar days after the date on which the unit commences commercial operation.

(3) The owner or operator of a CSAPR SO₂ Group 1 unit for which construction of a new stack or flue or installation of

**SECTION E. Source Group Restrictions.**

addon SO₂ emission controls is completed after the applicable deadline under paragraph (b)(1) or (2) of this section shall meet the requirements of §75.4(e)(1) through (4) of this chapter, except that:

(i) Such requirements shall apply to the monitoring systems required under §97.630 through §97.635, rather than the monitoring systems required under part 75 of this chapter;

(ii) SO₂ concentration, stack gas moisture content, stack gas volumetric flow rate, and O₂ or CO₂ concentration data shall be determined and reported, rather than the data listed in §75.4(e)(2) of this chapter; and

(iii) Any petition for another procedure under §75.4(e)(2) of this chapter shall be submitted under §97.635, rather than §75.66 of this chapter.

(c) **REPORTING DATA.** The owner or operator of a CSAPR SO₂ Group 1 unit that does not meet the applicable compliance date set forth in paragraph (b) of this section for any monitoring system under paragraph (a)(1) of this section shall, for each such monitoring system, determine, record, and report maximum potential (or, as appropriate, minimum potential) values for SO₂ concentration, stack gas flow rate, stack gas moisture content, fuel flow rate, and any other parameters required to determine SO₂ mass emissions and heat input in accordance with §75.31(b)(2) or (c)(3) of this chapter or section 2.4 of appendix D to part 75 of this chapter, as applicable.

(d) **PROHIBITIONS.**

(1) No owner or operator of a CSAPR SO₂ Group 1 unit shall use any alternative monitoring system, alternative reference method, or any other alternative to any requirement of this subpart without having obtained prior written approval in accordance with §97.635.

(2) No owner or operator of a CSAPR SO₂ Group 1 unit shall operate the unit so as to discharge, or allow to be discharged, SO₂ to the atmosphere without accounting for all such SO₂ in accordance with the applicable provisions of this subpart and part 75 of this chapter.

(3) No owner or operator of a CSAPR SO₂ Group 1 unit shall disrupt the continuous emission monitoring system, any portion thereof, or any other approved emission monitoring method, and thereby avoid monitoring and recording SO₂ mass discharged into the atmosphere or heat input, except for periods of recertification or periods when calibration, quality assurance testing, or maintenance is performed in accordance with the applicable provisions of this subpart and part 75 of this chapter.

(4) No owner or operator of a CSAPR SO₂ Group 1 unit shall retire or permanently discontinue use of the continuous emission monitoring system, any component thereof, or any other approved monitoring system under this subpart, except under any one of the following circumstances:

(i) During the period that the unit is covered by an exemption under §97.605 that is in effect;

(ii) The owner or operator is monitoring emissions from the unit with another certified monitoring system approved, in accordance with the applicable provisions of this subpart and part 75 of this chapter, by the Administrator for use at that unit that provides emission data for the same pollutant or parameter as the retired or discontinued monitoring system; or

(iii) The designated representative submits notification of the date of certification testing of a replacement monitoring system for the retired or discontinued monitoring system in accordance with §97.631(d)(3)(i).

(e) **LONG-TERM COLD STORAGE.** The owner or operator of a CSAPR SO₂ Group 1 unit is subject to the applicable provisions of §75.4(d) of this chapter concerning units in long-term cold storage.

[76 FR 48379, Aug. 8, 2011, as amended at 79 FR 71672, Dec. 3, 2014; 81 FR 74617, Oct. 26, 2016]

**# 009 [40 CFR Part 97 NO_x Budget Trading Program and CAIR NO_x and SO₂ Trading Programs §40 CFR 97.634]
Subpart CCCCC - CSAPR SO₂ Group 1 Trading Program
Recordkeeping and reporting.**

(a) **GENERAL PROVISIONS.** The designated representative shall comply with all recordkeeping and reporting requirements

**SECTION E. Source Group Restrictions.**

in paragraphs (b) through (e) of this section, the applicable recordkeeping and reporting requirements in subparts F and G of part 75 of this chapter, and the requirements of §97.614(a).

(b) **MONITORING PLANS.** The owner or operator of a CSAPR SO₂ Group 1 unit shall comply with the requirements of §75.62 of this chapter.

(c) **CERTIFICATION APPLICATIONS.** The designated representative shall submit an application to the Administrator within 45 days after completing all initial certification or recertification tests required under §97.631, including the information required under §75.63 of this chapter.

(d) **QUARTERLY REPORTS.** The designated representative shall submit quarterly reports, as follows:

(1) The designated representative shall report the SO₂ mass emissions data and heat input data for a CSAPR SO₂ Group 1 unit, in an electronic quarterly report in a format prescribed by the Administrator, for each calendar quarter beginning with the later of:

(i) The calendar quarter covering January 1, 2015 through March 31, 2015; or

(ii) The calendar quarter corresponding to the earlier of the date of provisional certification or the applicable deadline for initial certification under §97.630(b).

(2) The designated representative shall submit each quarterly report to the Administrator within 30 days after the end of the calendar quarter covered by the report. Quarterly reports shall be submitted in the manner specified in §75.64 of this chapter.

(3) For CSAPR SO₂ Group 1 units that are also subject to the Acid Rain Program, CSAPR NO_x Annual Trading Program, CSAPR NO_x Ozone Season Group 1 Trading Program, or CSAPR NO_x Ozone Season Group 2 Trading Program, quarterly reports shall include the applicable data and information required by subparts F through H of part 75 of this chapter as applicable, in addition to the SO₂ mass emission data, heat input data, and other information required by this subpart.

(4) The Administrator may review and conduct independent audits of any quarterly report in order to determine whether the quarterly report meets the requirements of this subpart and part 75 of this chapter, including the requirement to use substitute data.

(i) The Administrator will notify the designated representative of any determination that the quarterly report fails to meet any such requirements and specify in such notification any corrections that the Administrator believes are necessary to make through resubmission of the quarterly report and a reasonable time period within which the designated representative must respond. Upon request by the designated representative, the Administrator may specify reasonable extensions of such time period. Within the time period (including any such extensions) specified by the Administrator, the designated representative shall resubmit the quarterly report with the corrections specified by the Administrator, except to the extent the designated representative provides information demonstrating that a specified correction is not necessary because the quarterly report already meets the requirements of this subpart and part 75 of this chapter that are relevant to the specified correction.

(ii) Any resubmission of a quarterly report shall meet the requirements applicable to the submission of a quarterly report under this subpart and part 75 of this chapter, except for the deadline set forth in paragraph (d)(2) of this section.

(e) **COMPLIANCE CERTIFICATION.** The designated representative shall submit to the Administrator a compliance certification (in a format prescribed by the Administrator) in support of each quarterly report based on reasonable inquiry of those persons with primary responsibility for ensuring that all of the unit's emissions are correctly and fully monitored. The certification shall state that:

(1) The monitoring data submitted were recorded in accordance with the applicable requirements of this subpart and part 75 of this chapter, including the quality assurance procedures and specifications; and

(2) For a unit with add-on SO₂ emission controls and for all hours where SO₂ data are substituted in accordance with §75.34(a)(1) of this chapter, the add-on emission controls were operating within the range of parameters listed in the quality assurance/quality control program under appendix B to part 75 of this chapter and the substitute data values do not

**SECTION E. Source Group Restrictions.**

systematically underestimate SO₂ emissions.

[76 FR 48379, Aug. 8, 2011, as amended at 79 FR 71672, Dec. 3, 2014; 81 FR 74618, Oct. 26, 2016]

010 [40 CFR Part 97 NOx Budget Trading Program and CAIR NOx and SO₂ Trading Programs §40 CFR 97.804] Subpart EEEEE - CSAPR NOx Ozone Season Group 2 Trading Program Applicability.

(a) Boiler 1 (Source ID 031) and Boiler 2 (Source ID 032) are subject to the applicable requirements of 40 CFR Part 97, Subpart EEEEE - CSAPR NOx Ozone Season Group 2 Trading Program. As determined by 97.810 and adjusted on an annual basis by EPA, Boiler 1 (Source ID 031) and Boiler 2 (Source ID 032) are allocated the following CSAPR NOx Ozone Season (May 1 through September 30) allowances for the year 2020:

Year	NOx Ozone Season Group 2 Annual Allocation (tons)	
	Boiler 1 (Source ID 031)	Boiler 2 (Source ID 032)
2020	876	919

(b) The following sections of § 97 Subpart EEEEE are incorporated by reference. Compliance with equivalent sections of § 97 Subpart GGGGG also ensures compliance with these sections.

- (1) § 97.806 (Standard requirements).
- (2) § 97.830 (General monitoring, recordkeeping, & reporting).
- (3) § 97.834 (Recordkeeping & reporting).

[Effective June 29, 2021, § 97 Subpart GGGGG replaces § 97 Subpart EEEEE for Pennsylvania. The NOx ozone season allocations above will be used in calculating supplemental allowances for 2021 ozone season, specifically from May 1 through June 28, 2021 period.]

011 [40 CFR Part 97 NOx Budget Trading Program and CAIR NOx and SO₂ Trading Programs §40 CFR §97.1004] Subpart GGGGG - CSAPR NOx Ozone Season Group 3 Trading Program Applicability.

(a) Boiler 1 (Source ID 031) and Boiler 2 (Source ID 032) are subject to the applicable requirements of 40 CFR Part 97, Subpart GGGGG - CSAPR NOx Ozone Season Group 3 Trading Program. As determined by 97.1010 and adjusted on an annual basis by EPA, Boiler 1 (Source ID 031) and Boiler 2 (Source ID 032) are allocated the following CSAPR NOx Ozone Season (May 1 through September 30) allowances for the years 2021 through 2024:

Year	NOx Ozone Season Group 2 Annual Allocation (tons)	
	Boiler 1 (Source ID 031)	Boiler 2 (Source ID 032)
2021	660	604
2022	660	604
2023	660	604
2024	660	604

(b) In accordance with 40 CFR § § 97.1021, EPA will announce in a notice of data availability and record in the Boiler 1 and Boiler 2 Annual NOx Ozone Season Group 3 Compliance Account, the allowance allocations for control periods beyond the year 2024.

(c) The allowances in subsection (a) of this condition are subject to change. Any changes will be promulgated by US EPA in a notice of data availability. Upon promulgation, the new allowances replace the amounts in subsection (a) by rule.

[Effective June 29, 2021, § 97 Subpart GGGGG replaces § 97 Subpart EEEEE for Pennsylvania.]

**SECTION E. Source Group Restrictions.****# 012 [40 CFR Part 97 NOx Budget Trading Program and CAIR NOx and SO2 Trading Programs §40 CFR §97.1006]
Subpart GGGGG - CSAPR NOx Ozone Season Group 3 Trading Program
Standard requirements.**

(a) DESIGNATED REPRESENTATIVE REQUIREMENTS. The owners and operators shall comply with the requirement to have a designated representative, and may have an alternate designated representative, in accordance with §§ 97.1013 through 97.1018.

(b) EMISSIONS MONITORING, REPORTING, AND RECORDKEEPING REQUIREMENTS.

(1) The owners and operators, and the designated representative, of each CSAPR NOx Ozone Season Group 3 source and each CSAPR NOx Ozone Season Group 3 unit at the source shall comply with the monitoring, reporting, and recordkeeping requirements of §§ 97.1030 through 97.1035.

(2) The emissions data determined in accordance with §§ 97.1030 through 97.1035 shall be used to calculate allocations of CSAPR NOx Ozone Season Group 3 allowances under §§ 97.1011(a)(2) and (b) and 97.1012 and to determine compliance with the CSAPR NOx Ozone Season Group 3 emissions limitation and assurance provisions under paragraph (c) of this section, provided that, for each monitoring location from which mass emissions are reported, the mass emissions amount used in calculating such allocations and determining such compliance shall be the mass emissions amount for the monitoring location determined in accordance with §§ 97.1030 through 97.1035 and rounded to the nearest ton, with any fraction of a ton less than 0.50 being deemed to be zero.

(c) NOx EMISSIONS REQUIREMENTS.

(1) CSAPR NOx OZONE SEASON GROUP 3 EMISSIONS LIMITATION.

(i) As of the allowance transfer deadline for a control period in a given year, the owners and operators of each CSAPR NOx Ozone Season Group 3 source and each CSAPR NOx Ozone Season Group 3 unit at the source shall hold, in the source's compliance account, CSAPR NOx Ozone Season Group 3 allowances available for deduction for such control period under § 97.1024(a) in an amount not less than the tons of total NOx emissions for such control period from all CSAPR NOx Ozone Season Group 3 units at the source.

(ii) If total NOx emissions during a control period in a given year from the CSAPR NOx Ozone Season Group 3 units at a CSAPR NOx Ozone Season Group 3 source are in excess of the CSAPR NOx Ozone Season Group 3 emissions limitation set forth in paragraph (c)(1)(i) of this section, then:

(A) The owners and operators of the source and each CSAPR NOx Ozone Season Group 3 unit at the source shall hold the CSAPR NOx Ozone Season Group 3 allowances required for deduction under § 97.1024(d); and

(B) The owners and operators of the source and each CSAPR NOx Ozone Season Group 3 unit at the source shall pay any fine, penalty, or assessment or comply with any other remedy imposed, for the same violations, under the Clean Air Act, and each ton of such excess emissions and each day of such control period shall constitute a separate violation of this subpart and the Clean Air Act.

(2) CSAPR NOx OZONE SEASON GROUP 3 ASSURANCE PROVISIONS.

(i) If total NOx emissions during a control period in a given year from all base CSAPR NOx Ozone Season Group 3 units at base CSAPR NOx Ozone Season Group 3 sources in a State (and Indian country within the borders of such State) exceed the State assurance level, then the owners and operators of such sources and units in each group of one or more sources and units having a common designated representative for such control period, where the common designated representative's share of such NOx emissions during such control period exceeds the common designated representative's assurance level for the State and such control period, shall hold (in the assurance account established for the owners and operators of such group) CSAPR NOx Ozone Season Group 3 allowances available for deduction for such control period under § 97.1025(a) in an amount equal to two times the product (rounded to the nearest whole number), as determined by the Administrator in accordance with § 97.1025(b), of multiplying—

(A) The quotient of the amount by which the common designated representative's share of such NOx emissions exceeds the common designated representative's assurance level divided by the sum of the amounts, determined for all

**SECTION E. Source Group Restrictions.**

common designated representatives for such sources and units in the State (and Indian country within the borders of such State) for such control period, by which each common designated representative's share of such NOX emissions exceeds the respective common designated representative's assurance level; and

(B) The amount by which total NOX emissions from all base CSAPR NOX Ozone Season Group 3 units at base CSAPR NOX Ozone Season Group 3 sources in the State (and Indian country within the borders of such State) for such control period exceed the State assurance level.

(ii) The owners and operators shall hold the CSAPR NOX Ozone Season Group 3 allowances required under paragraph (c)(2)(i) of this section, as of midnight of November 1 (if it is a business day), or midnight of the first business day thereafter (if November 1 is not a business day), immediately after the year of such control period.

(iii) Total NOX emissions from all base CSAPR NOX Ozone Season Group 3 units at base CSAPR NOX Ozone Season Group 3 sources in a State (and Indian country within the borders of such State) during a control period in a given year exceed the State assurance level if such total NOX emissions exceed the sum, for such control period, of the State NOX Ozone Season Group 3 trading budget under § 97.1010(a) and the State's variability limit under §97.1010(b), and, for the control period in 2021 only, the product (rounded to the nearest allowance) of 1.21 multiplied by the supplemental amount of CSAPR NOX Ozone Season Group 3 allowances determined for the State under § 97.1010(d).

(iv) It shall not be a violation of this subpart or of the Clean Air Act if total NOX emissions from all base CSAPR NOX Ozone Season Group 3 units at base CSAPR NOX Ozone Season Group 3 sources in a State (and Indian country within the borders of such State) during a control period exceed the State assurance level or if a common designated representative's share of total NOX emissions from the base CSAPR NOX Ozone Season Group 3 units at base CSAPR NOX Ozone Season Group 3 sources in a State (and Indian country within the borders of such State) during a control period exceeds the common designated representative's assurance level.

(v) To the extent the owners and operators fail to hold CSAPR NOX Ozone Season Group 3 allowances for a control period in a given year in accordance with paragraphs (c)(2)(i) through (iii) of this section,

(A) The owners and operators shall pay any fine, penalty, or assessment or comply with any other remedy imposed under the Clean Air Act; and

(B) Each CSAPR NOX Ozone Season Group 3 allowance that the owners and operators fail to hold for such control period in accordance with paragraphs (c)(2)(i) through (iii) of this section and each day of such control period shall constitute a separate violation of this subpart and the Clean Air Act.

(3) COMPLIANCE PERIODS.

(i) A CSAPR NOX Ozone Season Group 3 unit shall be subject to the requirements under paragraph (c)(1) of this section for the control period starting on the later of May 1, 2021 or the deadline for meeting the unit's monitor certification requirements under § 97.1030(b) and for each control period thereafter.

(ii) A base CSAPR NOX Ozone Season Group 3 unit shall be subject to the requirements under paragraph (c)(2) of this section for the control period starting on the later of May 1, 2021 or the deadline for meeting the unit's monitor certification requirements under § 97.1030(b) and for each control period thereafter.

(4) VINTAGE OF CSAPR NOX OZONE SEASON GROUP 3 ALLOWANCES HELD FOR COMPLIANCE.

(i) A CSAPR NOX Ozone Season Group 3 allowance held for compliance with the requirements under paragraph (c)(1)(i) of this section for a control period in a given year must be a CSAPR NOX Ozone Season Group 3 allowance that was allocated or auctioned for such control period or a control period in a prior year.

(ii) A CSAPR NOX Ozone Season Group 3 allowance held for compliance with the requirements under paragraphs (c)(1)(ii)(A) and (c)(2)(i) through (iii) of this section for a control period in a given year must be a CSAPR NOX Ozone Season Group 3 allowance that was allocated or auctioned for a control period in a prior year or the control period in the given year or in the immediately following year.

**SECTION E. Source Group Restrictions.**

(5) ALLOWANCE MANAGEMENT SYSTEM REQUIREMENTS. Each CSAPR NOX Ozone Season Group 3 allowance shall be held in, deducted from, or transferred into, out of, or between Allowance Management System accounts in accordance with this subpart.

(6) LIMITED AUTHORIZATION. A CSAPR NOX Ozone Season Group 3 allowance is a limited authorization to emit one ton of NOX during the control period in one year. Such authorization is limited in its use and duration as follows:

(i) Such authorization shall only be used in accordance with the CSAPR NOX Ozone Season Group 3 Trading Program; and

(ii) Notwithstanding any other provision of this subpart, the Administrator has the authority to terminate or limit the use and duration of such authorization to the extent the Administrator determines is necessary or appropriate to implement any provision of the Clean Air Act.

(7) PROPERTY RIGHT. A CSAPR NOX Ozone Season Group 3 allowance does not constitute a property right.

(d) TITLE V PERMIT REQUIREMENTS.

(1) No title V permit revision shall be required for any allocation, holding, deduction, or transfer of CSAPR NOX Ozone Season Group 3 allowances in accordance with this subpart.

(2) A description of whether a unit is required to monitor and report NOX emissions using a continuous emission monitoring system (under subpart H of part 75 of this chapter), an excepted monitoring system (under appendices D and E to part 75 of this chapter), a low mass emissions excepted monitoring methodology (under §75.19 of this chapter), or an alternative monitoring system (under subpart E of part 75 of this chapter) in accordance with §§ 97.1030 through 97.1035 may be added to, or changed in, a title V permit using minor permit modification procedures in accordance with §§70.7(e)(2) and 71.7(e)(1) of this chapter, provided that the requirements applicable to the described monitoring and reporting (as added or changed, respectively) are already incorporated in such permit. This paragraph explicitly provides that the addition of, or change to, a unit's description as described in the prior sentence is eligible for minor permit modification procedures in accordance with §§70.7(e)(2)(i)(B) and 71.7(e)(1)(i)(B) of this chapter.

(e) ADDITIONAL RECORDKEEPING AND REPORTING REQUIREMENTS.

(1) Unless otherwise provided, the owners and operators of each CSAPR NOX Ozone Season Group 3 source and each CSAPR NOX Ozone Season Group 3 unit at the source shall keep on site at the source each of the following documents (in hardcopy or electronic format) for a period of 5 years from the date the document is created. This period may be extended for cause, at any time before the end of 5 years, in writing by the Administrator.

(i) The certificate of representation under § 97.1016 for the designated representative for the source and each CSAPR NOX Ozone Season Group 3 unit at the source and all documents that demonstrate the truth of the statements in the certificate of representation; provided that the certificate and documents shall be retained on site at the source beyond such 5-year period until such certificate of representation and documents are superseded because of the submission of a new certificate of representation under § 97.1016 changing the designated representative.

(ii) All emissions monitoring information, in accordance with this subpart.

(iii) Copies of all reports, compliance certifications, and other submissions and all records made or required under, or to demonstrate compliance with the requirements of, the CSAPR NOX Ozone Season Group 3 Trading Program.

(2) The designated representative of a CSAPR NOX Ozone Season Group 3 source and each CSAPR NOX Ozone Season Group 3 unit at the source shall make all submissions required under the CSAPR NOX Ozone Season Group 3 Trading Program, except as provided in § 97.1018. This requirement does not change, create an exemption from, or otherwise affect the responsible official submission requirements under a title V operating permit program in parts 70 and 71 of this chapter.

(f) LIABILITY.

**SECTION E. Source Group Restrictions.**

(1) Any provision of the CSAPR NOX Ozone Season Group 3 Trading Program that applies to a CSAPR NOX Ozone Season Group 3 source or the designated representative of a CSAPR NOX Ozone Season Group 3 source shall also apply to the owners and operators of such source and of the CSAPR NOX Ozone Season Group 3 units at the source.

(2) Any provision of the CSAPR NOX Ozone Season Group 3 Trading Program that applies to a CSAPR NOX Ozone Season Group 3 unit or the designated representative of a CSAPR NOX Ozone Season Group 3 unit shall also apply to the owners and operators of such unit.

(g) EFFECT ON OTHER AUTHORITIES. No provision of the CSAPR NOX Ozone Season Group 3 Trading Program or exemption under § 97.1005 shall be construed as exempting or excluding the owners and operators, and the designated representative, of a CSAPR NOX Ozone Season Group 3 source or CSAPR NOX Ozone Season Group 3 unit from compliance with any other provision of the applicable, approved State implementation plan, a federally enforceable permit, or the Clean Air Act.

**# 013 [40 CFR Part 97 NOx Budget Trading Program and CAIR NOx and SO2 Trading Programs §40 CFR §97.1030]
Subpart GGGGG - CSAPR NOX Ozone Season Group 3 Trading Program
General monitoring, recordkeeping, and reporting requirements.**

The owners and operators, and to the extent applicable, the designated representative, of a CSAPR NOX Ozone Season Group 3 unit, shall comply with the monitoring, recordkeeping, and reporting requirements as provided in this subpart and subpart H of part 75 of this chapter. For purposes of applying such requirements, the definitions in § 97.1002 and in § 72.2 of this chapter shall apply, the terms "affected unit," "designated representative," and "continuous emission monitoring system" (or "CEMS") in part 75 of this chapter shall be deemed to refer to the terms "CSAPR NOX Ozone Season Group 3 unit," "designated representative," and "continuous emission monitoring system" (or "CEMS") respectively as defined in § 97.1002, and the term "newly affected unit" shall be deemed to mean "newly affected CSAPR NOX Ozone Season Group 3 unit". The owner or operator of a unit that is not a CSAPR NOX Ozone Season Group 3 unit but that is monitored under §75.72(b)(2)(ii) of this chapter shall comply with the same monitoring, recordkeeping, and reporting requirements as a CSAPR NOX Ozone Season Group 3 unit.

(a) REQUIREMENTS FOR INSTALLATION, CERTIFICATION, AND DATA ACCOUNTING. The owner or operator of each CSAPR NOX Ozone Season Group 3 unit shall:

(1) Install all monitoring systems required under this subpart for monitoring NOX mass emissions and individual unit heat input (including all systems required to monitor NOX emission rate, NOX concentration, stack gas moisture content, stack gas flow rate, CO2 or O2 concentration, and fuel flow rate, as applicable, in accordance with §§75.71 and 75.72 of this chapter);

(2) Successfully complete all certification tests required under § 97.1031 and meet all other requirements of this subpart and part 75 of this chapter applicable to the monitoring systems under paragraph (a)(1) of this section; and

(3) Record, report, and quality-assure the data from the monitoring systems under paragraph (a)(1) of this section.

(b) COMPLIANCE DEADLINES. Except as provided in paragraph (e) of this section, the owner or operator of a CSAPR NOX Ozone Season Group 3 unit shall meet the monitoring system certification and other requirements of paragraphs (a)(1) and (2) of this section on or before the latest of the following dates and shall record, report, and quality-assure the data from the monitoring systems under paragraph (a)(1) of this section on and after the latest of the following dates:

(1) May 1, 2021;

(2) 180 calendar days after the date on which the unit commences commercial operation; or

(3) Where data for the unit are reported on a control period basis under § 97.1034(d)(1)(ii)(B), and where the compliance date under paragraph (b)(2) of this section is not in a month from May through September, May 1 immediately after the compliance date under paragraph (b)(2) of this section.

(4) The owner or operator of a CSAPR NOX Ozone Season Group 3 unit for which construction of a new stack or flue or installation of add-on NOX emission controls is completed after the applicable deadline under paragraph (b)(1), (2), or (3) of this section shall meet the requirements of §75.4(e)(1) through (4) of this chapter, except that:

**SECTION E. Source Group Restrictions.**

(i) Such requirements shall apply to the monitoring systems required under § 97.1030 through §97.1035, rather than the monitoring systems required under part 75 of this chapter;

(ii) NOX emission rate, NOX concentration, stack gas moisture content, stack gas volumetric flow rate, and O2 or CO2 concentration data shall be determined and reported, rather than the data listed in §75.4(e)(2) of this chapter; and

(iii) Any petition for another procedure under §75.4(e)(2) of this chapter shall be submitted under § 97.1035, rather than §75.66 of this chapter.

(c) REPORTING DATA. The owner or operator of a CSAPR NOX Ozone Season Group 3 unit that does not meet the applicable compliance date set forth in paragraph (b) of this section for any monitoring system under paragraph (a)(1) of this section shall, for each such monitoring system, determine, record, and report maximum potential (or, as appropriate, minimum potential) values for NOX concentration, NOX emission rate, stack gas flow rate, stack gas moisture content, fuel flow rate, and any other parameters required to determine NOX mass emissions and heat input in accordance with §75.31(b)(2) or (c)(3) of this chapter, section 2.4 of appendix D to part 75 of this chapter, or section 2.5 of appendix E to part 75 of this chapter, as applicable.

(d) PROHIBITIONS.

(1) No owner or operator of a CSAPR NOX Ozone Season Group 3 unit shall use any alternative monitoring system, alternative reference method, or any other alternative to any requirement of this subpart without having obtained prior written approval in accordance with § 97.1035.

(2) No owner or operator of a CSAPR NOX Ozone Season Group 3 unit shall operate the unit so as to discharge, or allow to be discharged, NOX to the atmosphere without accounting for all such NOX in accordance with the applicable provisions of this subpart and part 75 of this chapter.

(3) No owner or operator of a CSAPR NOX Ozone Season Group 3 unit shall disrupt the continuous emission monitoring system, any portion thereof, or any other approved emission monitoring method, and thereby avoid monitoring and recording NOX mass discharged into the atmosphere or heat input, except for periods of recertification or periods when calibration, quality assurance testing, or maintenance is performed in accordance with the applicable provisions of this subpart and part 75 of this chapter.

(4) No owner or operator of a CSAPR NOX Ozone Season Group 3 unit shall retire or permanently discontinue use of the continuous emission monitoring system, any component thereof, or any other approved monitoring system under this subpart, except under any one of the following circumstances:

(i) During the period that the unit is covered by an exemption under § 97.1005 that is in effect;

(ii) The owner or operator is monitoring emissions from the unit with another certified monitoring system approved, in accordance with the applicable provisions of this subpart and part 75 of this chapter, by the Administrator for use at that unit that provides emission data for the same pollutant or parameter as the retired or discontinued monitoring system; or

(iii) The designated representative submits notification of the date of certification testing of a replacement monitoring system for the retired or discontinued monitoring system in accordance with § 97.1031(d)(3)(i).

014 [40 CFR Part 97 NOx Budget Trading Program and CAIR NOx and SO2 Trading Programs §40 CFR §97.1034] Subpart GGGGG - CSAPR NOX Ozone Season Group 3 Trading Program Recordkeeping and reporting.

(a) GENERAL PROVISIONS. The designated representative shall comply with all recordkeeping and reporting requirements in paragraphs (b) through (e) of this section, the applicable recordkeeping and reporting requirements under §75.73 of this chapter, and the requirements of § 97.1014(a).

(b) MONITORING PLANS. The owner or operator of a CSAPR NOX Ozone Season Group 3 unit shall comply with the requirements of §75.73(c) and (e) of this chapter.

(c) CERTIFICATION APPLICATIONS. The designated representative shall submit an application to the Administrator within

SECTION E. Source Group Restrictions.

45 days after completing all initial certification or recertification tests required under § 97.1031, including the information required under §75.63 of this chapter.

(d) QUARTERLY REPORTS. The designated representative shall submit quarterly reports, as follows:

(1)

(i) If a CSAPR NOX Ozone Season Group 3 unit is subject to the Acid Rain Program or the CSAPR NOX Annual Trading Program or if the owner or operator of such unit chooses to report on an annual basis under this subpart, then the designated representative shall meet the requirements of subpart H of part 75 of this chapter (concerning monitoring of NOX mass emissions) for such unit for the entire year and report the NOX mass emissions data and heat input data for such unit for the entire year.

(ii) If a CSAPR NOX Ozone Season Group 3 unit is not subject to the Acid Rain Program or the CSAPR NOX Annual Trading Program, then the designated representative shall either:

(A) Meet the requirements of subpart H of part 75 of this chapter for such unit for the entire year and report the NOX mass emissions data and heat input data for such unit for the entire year in accordance with paragraph (d)(1)(i) of this section; or

(B) Meet the requirements of subpart H of part 75 of this chapter (including the requirements in §75.74(c) of this chapter) for such unit for the control period and report the NOX mass emissions data and heat input data (including the data described in §75.74(c)(6) of this chapter) for such unit only for the control period of each year.

(2) The designated representative shall report the NOX mass emissions data and heat input data for a CSAPR NOX Ozone Season Group 3 unit, in an electronic quarterly report in a format prescribed by the Administrator, for each calendar quarter indicated under paragraph (d)(1) of this section beginning by the latest of:

(i) The calendar quarter covering May 1, 2021 through June 30, 2021;

(ii) The calendar quarter corresponding to the earlier of the date of provisional certification or the applicable deadline for initial certification under § 97.1030(b); or

(iii) For a unit that reports on a control period basis under paragraph (d)(1)(ii)(B) of this section, if the calendar quarter under paragraph (d)(2)(ii) of this section does not include a month from May through September, the calendar quarter covering May 1 through June 30 immediately after the calendar quarter under paragraph (d)(2)(ii) of this section.

(3) The designated representative shall submit each quarterly report to the Administrator within 30 days after the end of the calendar quarter covered by the report. Quarterly reports shall be submitted in the manner specified in §75.73(f) of this chapter.

(4) For CSAPR NOX Ozone Season Group 3 units that are also subject to the Acid Rain Program, CSAPR NOX Annual Trading Program, CSAPR SO₂ Group 1 Trading Program, or CSAPR SO₂ Group 2 Trading Program, quarterly reports shall include the applicable data and information required by subparts F through H of part 75 of this chapter as applicable, in addition to the NOX mass emission data, heat input data, and other information required by this subpart.

(5) The Administrator may review and conduct independent audits of any quarterly report in order to determine whether the quarterly report meets the requirements of this subpart and part 75 of this chapter, including the requirement to use substitute data.

(i) The Administrator will notify the designated representative of any determination that the quarterly report fails to meet any such requirements and specify in such notification any corrections that the Administrator believes are necessary to make through resubmission of the quarterly report and a reasonable time period within which the designated representative must respond. Upon request by the designated representative, the Administrator may specify reasonable extensions of such time period. Within the time period (including any such extensions) specified by the Administrator, the designated representative shall resubmit the quarterly report with the corrections specified by the Administrator, except to the extent the designated representative provides information demonstrating that a specified correction is not necessary

**SECTION E. Source Group Restrictions.**

because the quarterly report already meets the requirements of this subpart and part 75 of this chapter that are relevant to the specified correction.

(ii) Any resubmission of a quarterly report shall meet the requirements applicable to the submission of a quarterly report under this subpart and part 75 of this chapter, except for the deadline set forth in paragraph (d)(3) of this section.

(e) COMPLIANCE CERTIFICATION. The designated representative shall submit to the Administrator a compliance certification (in a format prescribed by the Administrator) in support of each quarterly report based on reasonable inquiry of those persons with primary responsibility for ensuring that all of the unit's emissions are correctly and fully monitored. The certification shall state that:

(1) The monitoring data submitted were recorded in accordance with the applicable requirements of this subpart and part 75 of this chapter, including the quality assurance procedures and specifications;

(2) For a unit with add-on NOX emission controls and for all hours where NOX data are substituted in accordance with §75.34(a)(1) of this chapter, the add-on emission controls were operating within the range of parameters listed in the quality assurance/quality control program under appendix B to part 75 of this chapter and the substitute data values do not systematically underestimate NOX emissions; and

(3) For a unit that is reporting on a control period basis under paragraph (d)(1)(ii)(B) of this section, the NOX emission rate and NOX concentration values substituted for missing data under subpart D of part 75 of this chapter are calculated using only values from a control period and do not systematically underestimate NOX emissions.

*** **Permit Shield in Effect.** ***

**SECTION E. Source Group Restrictions.**

Group Name: G03

Group Description: FGD Material Handling Operations

Sources included in this group

ID	Name
111	LIMESTONE HANDLING, PROCESSING, AND STORAGE OPERATIONS
112	GYPSUM PRODUCTION, PROCESSING, AND HANDLING OPERATIONS

I. RESTRICTIONS.**Emission Restriction(s).****# 001 [25 Pa. Code §127.441]****Operating permit terms and conditions.**

All conveyors associated with limestone and gypsum handling operations, shall be fully enclosed or equipped with 3- sided covers (top and two sides) except those conveyors or portions of conveyors, which are located underground or inside a fully enclosed building.

[From PA-03-00027B, Section E, Group ID 2, FGD Material Handling Operations, Condition #001]

II. TESTING REQUIREMENTS.

No additional testing requirements exist except as provided in other sections of this permit including Section B (Title V General Requirements).

III. MONITORING REQUIREMENTS.

No additional monitoring requirements exist except as provided in other sections of this permit including Section B (Title V General Requirements).

IV. RECORDKEEPING REQUIREMENTS.

No additional record keeping requirements exist except as provided in other sections of this permit including Section B (Title V General Requirements).

V. REPORTING REQUIREMENTS.

No additional reporting requirements exist except as provided in other sections of this permit including Section B (Title V General Requirements).

VI. WORK PRACTICE REQUIREMENTS.**# 002 [25 Pa. Code §127.441]****Operating permit terms and conditions.**

(a) An operable water truck shall be available at all times for use in the control of fugitive particulate matter from roadways, stockpiles, etc. during operations of the above sources. The water truck shall be equipped with a pressurized water spray bar as well as with a pressurized spray gun or hose connection. The permittee shall use the water truck, weather permitting, whenever the potential for fugitive emissions is present. When use of the water truck presents an icing hazard, a dry vacuum sweeper shall be used to control haul road dust.

(b) The permittee shall not operate non-vacuum type road sweepers on the roadways associated with the above sources.

(c) If, at any time, any component of the above operations is determined by the Department to be causing the emission of fugitive particulate matter in excess of the limitations specified in 25 Pa. Code §§ 123.1 and 123.2 or in excess of the level which the Department considers to be the minimum attainable through the use of the best available technology or in excess of the requirements under 40 CFR §60.672, the permittee shall, upon notification by the Department, immediately install additional water sprays and/or take such other control measures as are necessary to reduce the fugitive particulate matter to acceptable levels.

**SECTION E. Source Group Restrictions.**

(d) The permittee shall establish, and enforce, a vehicle speed limit of 15 miles per hour on the roadways associated with the above sources. This speed limit shall be posted in highly visible locations along the respective roadways.

(e) All trucks loaded with lime, limestone or gypsum that enter or exit the facility via a public roadway shall either be fully enclosed or have their loads tarped. This requirement shall be posted in highly visible locations within the facility.

(f) A truck tire wash station shall be available for use, weather permitting, whenever off-site truck shipments of gypsum occur.

[From PA-03-00027B, Section E, Group ID 2, FGD Material Handling Operations, Condition #002]

VII. ADDITIONAL REQUIREMENTS.

No additional requirements exist except as provided in other sections of this permit including Section B (Title V General Requirements).

***** Permit Shield in Effect. *****

**SECTION E. Source Group Restrictions.**

Group Name: G04

Group Description: Auxiliary Boilers A and B

Sources included in this group

ID	Name
037	AUX BOILER A
038	AUX BOILER B

I. RESTRICTIONS.**Emission Restriction(s).****# 001 [25 Pa. Code §123.11]****Combustion units**

A person may not permit the emission into the outdoor atmosphere of particulate matter from the combined flue of Auxiliary Boilers A and B in excess of the rate of 0.228 pounds per million Btu of heat input.

002 [25 Pa. Code §123.21]**General**

(a) Nonair basin areas. Combustion units in nonair basin areas must conform with the following:

(1) General provision. A person may not permit the emission into the outdoor atmosphere of sulfur oxides, expressed as SO₂, from a combustion unit in excess of the rate of 4 pounds per million Btu of heat input over a 1-hour period, except as provided in paragraph (4).

(2) Commercial fuel oil.

(i) Except as specified in subparagraphs (ii) and (iii), a person may not offer for sale, deliver for use, exchange in trade or permit the use of commercial fuel oil in nonair basin areas if the commercial fuel oil contains sulfur in excess of the applicable maximum allowable sulfur content set forth in the following tables:

Grades Commercial Fuel Oil	Maximum Allowable % Sulfur by Weight through June 30, 2016
No. 2 and Lighter (viscosity less than or equal to 5.820cSt)	0.5
No. 4, No. 5, No. 6 and heavier (viscosity greater than 5.82cSt)	2.8

Maximum Allowable Sulfur Content Beginning July 1, 2016,

Grades Commercial Fuel Oil (Consistent with ASTM D396)	Expressed as Parts per Million (ppm) by Weight or Percentage by Weight
No. 2 and lighter oil	500 ppm (0.05%)
No. 4 oil	2,500 ppm (0.25%)
No. 5, No. 6 and heavier oil	5,000 ppm (0.5%)

(ii) Commercial fuel oil that was stored in this Commonwealth by the ultimate consumer prior to July 1, 2016, which met the applicable maximum allowable sulfur content for commercial fuel oil through June 30, 2016, in subparagraph (i) at the time it was stored, may be used by the ultimate consumer in this Commonwealth on and after July 1, 2016.

(iii) Beginning July 1, 2016, the Department may temporarily suspend or increase the applicable maximum allowable sulfur content for a commercial fuel oil set forth in subparagraph (i) if the following occur:

(A) The Department receives a written request at the address specified in subsection (h) for a suspension or increase on the basis that compliant commercial fuel oil is not reasonably available in a nonair basin area. The request must include the following:

(l) The nonair basin county or counties for which the suspension or increase is requested.

**SECTION E. Source Group Restrictions.**

(II) The reason compliant commercial fuel oil is not reasonably available.

(III) The duration of time for which the suspension or increase is requested and the justification for the requested duration.

(B) The Department determines that an insufficient quantity of compliant commercial fuel oil is reasonably available in the nonair basin area and that the circumstances leading to the insufficiency are due to events that could not have been reasonably foreseen or prevented and are not due to lack of prudent planning on the part of the transferor of the commercial fuel oil into or within the specified nonair basin area.

(C) The Department approves the request, in writing, prior to the transferor distributing the noncompliant commercial fuel oil into or within the specified nonair basin area.

(iv) The Department will limit a suspension or increase in the applicable maximum allowable sulfur content granted under subparagraph (iii) to the shortest duration in which adequate supplies of compliant commercial fuel oil can be made reasonably available, but in no case longer than 60 days from the date the Department grants the suspension or increase.

(3) Equivalency provision. Paragraph (2) does not apply to a person who uses equipment or a process, or to the owner or operator of an installation where equipment or a process is used, to reduce the sulfur emissions from the burning of a fuel with a higher sulfur content than that specified in paragraph (2). The emissions may not exceed those which would result from the use of commercial fuel oil that meets the applicable maximum allowable sulfur content specified in paragraph (2).

(4) Not applicable.

(b)-(e) Not applicable.

(f) Sampling and testing.

(1) For the purpose of determining compliance with the requirements of this section, the actual sulfur content of commercial fuel oil shall be determined by one of the following:

(i) In accordance with the sample collection, test methods and procedures specified under § 139.16 (relating to sulfur in fuel oil).

(ii) Other methods developed or approved by the Department or the Administrator of the EPA, or both.

(2) Beginning July 1, 2016, a refinery owner or operator who produces commercial fuel oil intended for use or used in this Commonwealth is required to sample, test and calculate the actual sulfur content of each batch of the commercial fuel oil as specified in paragraph (1).

(3) Beginning July 1, 2016, and prior to offering for sale, delivering for use, exchanging in trade or permitting the use of commercial fuel oil in this Commonwealth, a person other than the ultimate consumer that accepts a shipment of commercial fuel oil from a refinery or other transferor, shall sample, test and calculate the actual sulfur content of the commercial fuel oil in accordance with paragraph (1) if the shipment lacks the record required under subsection (g)(1) that enables the transferee to determine if the sulfur content of the shipment of commercial fuel oil meets the applicable maximum allowable sulfur content.

(g) Recordkeeping and reporting.

(1) Beginning with the refinery owner or operator who sells or transfers commercial fuel oil into or within this Commonwealth for use in this Commonwealth and ending with the ultimate consumer, each time the physical custody of, or title to, a shipment of commercial fuel oil changes hands on or after July 1, 2016, the transferor shall provide to the transferee an electronic or paper record described in this paragraph. This record must legibly and conspicuously contain the following information:

(i) The date of the sale or transfer.

(ii) The name and address of the transferor.

(iii) The name and address of the transferee.

**SECTION E. Source Group Restrictions.**

- (iv) The volume of commercial fuel oil being sold or transferred.
- (v) The identification of the sulfur content of the shipment of commercial fuel oil, determined using the sampling and testing methods specified in subsection (f)(1), expressed as one of the following statements:
 - (A) For a shipment of No. 2 and lighter commercial fuel oil, "The sulfur content of this shipment is 500 ppm or below."
 - (B) For a shipment of No. 4 commercial fuel oil, "The sulfur content of this shipment is 2,500 ppm or below."
 - (C) For a shipment of No. 5, No. 6 and heavier commercial fuel oil, "The sulfur content of this shipment is 5,000 ppm or below."
- (vi) The location of the commercial fuel oil at the time of transfer.
- (vii) Except for a transfer to a truck carrier, an owner or operator of a retail outlet or an ultimate consumer, the transferor may substitute the information required under subparagraphs (i)—(vi) with the use of a product code if the following are met:
 - (A) The product code includes the information required under subparagraphs (i)—(vi).
 - (B) The product code is standardized throughout the distribution system in which it is used.
 - (C) Each downstream party is given sufficient information to know the full meaning of the product code.
- (2) The refinery owner or operator shall do both of the following:
 - (i) Maintain, in electronic or paper format, the records developed under subsection (f)(2) to determine the actual sulfur content of each batch of the commercial fuel oil.
 - (ii) Provide electronic or written copies of the records developed under subsection (f)(2) of the actual sulfur content of each batch of the commercial fuel oil to the Department upon request.
- (3) The terminal owner or operator shall do both of the following:
 - (i) Maintain, in electronic or paper format, the applicable records developed under subsection (f)(3) or (g)(1), or both, to establish the maximum sulfur content of the shipment of commercial fuel oil.
 - (ii) Provide electronic or written copies of the records establishing the maximum sulfur content of the shipment of commercial fuel oil to the Department upon request.
- (4) A person subject to this section shall do both of the following:
 - (i) Maintain the applicable records required under paragraphs (1)—(3) in electronic or paper format for 2 years unless a longer period is required under § 127.511(b)(2) (relating to monitoring and related recordkeeping and reporting requirements).
 - (ii) Provide an electronic or written copy of the applicable record to the Department upon request.
- (5) The ultimate consumer shall maintain in electronic or paper format the record containing the information listed in paragraph (1), except in either of the following situations:
 - (i) The transfer or use of the commercial fuel oil occurs at a private residence.
 - (ii) The ultimate consumer is an owner of an apartment or condominium building housing private residents and the transfer or use of the commercial fuel oil occurs for use at the building.
- (h) Written request. The written request for suspension of or increase in the sulfur content limit on the basis that compliant commercial fuel oil is not reasonably available shall be addressed to the Department of Environmental Protection, Bureau of Air Quality, Chief of the Division of Compliance and Enforcement, P. O. Box 8468, Harrisburg, Pennsylvania 17105-8468.

**SECTION E. Source Group Restrictions.****II. TESTING REQUIREMENTS.**

No additional testing requirements exist except as provided in other sections of this permit including Section B (Title V General Requirements).

III. MONITORING REQUIREMENTS.**# 003 [25 Pa. Code §127.441]****Operating permit terms and conditions.**

(a) If one or both of the Auxiliary Boilers operate for 24 consecutive hours, the permittee shall conduct a visible emission survey of the boiler(s) within 24 hours of start up.

(b) Visible emissions may be measured according to the methods specified in §123.43. As an alternative, plant personnel who observe emissions with the potential to exceed the limitations of §123.41 shall report each incident to the Department within four hours of the occurrence and arrange for a certified observer to read the visible emissions.

IV. RECORDKEEPING REQUIREMENTS.**# 004 [25 Pa. Code §127.441]****Operating permit terms and conditions.**

The permittee shall maintain a logbook of all visible emission surveys performed. The logbook shall include any observed incidences of potential visible emissions exceedances, the name of the person performing the inspection, date and time of inspection, and any corrective action or notification for observed incidents.

Records shall be retained for at least five years and made available to the Department upon request.

V. REPORTING REQUIREMENTS.

No additional reporting requirements exist except as provided in other sections of this permit including Section B (Title V General Requirements).

VI. WORK PRACTICE REQUIREMENTS.

No additional work practice requirements exist except as provided in other sections of this permit including Section B (Title V General Requirements).

VII. ADDITIONAL REQUIREMENTS.**# 005 [40 CFR Part 63 NESHAPS for Source Categories §40 CFR 63.7485]****Subpart DDDDD - National Emission Standards for Hazardous Air Pollutants for Major Sources: Industrial, Commercial and Institutional Boilers and Process Heaters.****Am I subject to this subpart?**

You are subject to this subpart if you own or operate an industrial, commercial, or institutional boiler or process heater as defined in §63.7575 that is located at, or is part of, a major source of HAP, except as specified in §63.7491. For purposes of this subpart, a major source of HAP is as defined in §63.2, except that for oil and natural gas production facilities, a major source of HAP is as defined in §63.7575.

[The two Auxiliary Boilers (Source IDs 037 and 038) are affected sources for the purposes of National Emission Standards for Hazardous Air Pollutants: Industrial, Commercial, and Institutional Boilers and Process Heaters. They shall be operated as limited use boilers for the purposes of Subpart DDDDD. As the owner and operator of Source IDs 037 and 038, the permittee shall comply with all applicable requirements codified in 40 CFR Part 63 Subpart DDDDD, 40 CFR §§ 63.7480 through 63.7575, including Tables and Appendices.]

006 [40 CFR Part 63 NESHAPS for Source Categories §40 CFR 63.7500]**Subpart DDDDD - National Emission Standards for Hazardous Air Pollutants for Major Sources: Industrial, Commercial and Institutional Boilers and Process Heaters.****What emission limits, work practice standards, and operating limits must I meet?**

(a) You must meet the requirements in paragraphs (a)(1) through (3) of this section, except as provided in paragraphs (b), through (e) of this section. You must meet these requirements at all times the affected unit is operating, except as provided in paragraph (f) of this section.

**SECTION E. Source Group Restrictions.**

(1) You must meet each emission limit and work practice standard in Tables 1 through 3, and 11 through 13 to this subpart that applies to your boiler or process heater, for each boiler or process heater at your source, except as provided under §63.7522. The output-based emission limits, in units of pounds per million Btu of steam output, in Tables 1 or 2 to this subpart are an alternative applicable only to boilers and process heaters that generate either steam, cogenerate steam with electricity, or both. The output-based emission limits, in units of pounds per megawatt-hour, in Tables 1 or 2 to this subpart are an alternative applicable only to boilers that generate only electricity. Boilers that perform multiple functions (cogeneration and electricity generation) or supply steam to common headers would calculate a total steam energy output using equation 21 of §63.7575 to demonstrate compliance with the output-based emission limits, in units of pounds per million Btu of steam output, in Tables 1 or 2 to this subpart. If you operate a new boiler or process heater, you can choose to comply with alternative limits as discussed in paragraphs (a)(1)(i) through (iii) of this section, but on or after January 31, 2016, you must comply with the emission limits in Table 1 to this subpart.

(2) Not applicable.

(3) At all times, you must operate and maintain any affected source (as defined in §63.7490), including associated air pollution control equipment and monitoring equipment, in a manner consistent with safety and good air pollution control practices for minimizing emissions. Determination of whether such operation and maintenance procedures are being used will be based on information available to the Administrator that may include, but is not limited to, monitoring results, review of operation and maintenance procedures, review of operation and maintenance records, and inspection of the source.

(b) Not applicable.

(c) Limited-use boilers and process heaters must complete a tune-up every 5 years as specified in §63.7540. They are not subject to the emission limits in Tables 1 and 2 or 11 through 13 to this subpart, the annual tune-up, or the energy assessment requirements in Table 3 to this subpart, or the operating limits in Table 4 to this subpart.

(d)-(e) Not applicable.

(f) These standards apply at all times the affected unit is operating, except during periods of startup and shutdown during which time you must comply only with items 5 and 6 of Table 3 to this subpart.

(Table 3 states: If your unit is a limited use boiler, you must meet the following: Conduct a tune-up of the boiler or process heater every 5 years as specified in § 63.7540.)

007 [40 CFR Part 63 NESHAPS for Source Categories §40 CFR 63.7510]

Subpart DDDDD - National Emission Standards for Hazardous Air Pollutants for Major Sources: Industrial, Commercial and Institutional Boilers and Process Heaters.

What are my initial compliance requirements and by what date must I conduct them?

(a) - (d) Not applicable.

(e) For existing affected sources (as defined in §63.7490), you must complete the initial compliance demonstrations, as specified in paragraphs (a) through (d) of this section, no later than 180 days after the compliance date that is specified for your source in §63.7495 and according to the applicable provisions in §63.7(a)(2) as cited in Table 10 to this subpart, except as specified in paragraph (j) of this section. You must complete an initial tune-up by following the procedures described in §63.7540(a)(10)(i) through (vi) no later than the compliance date specified in §63.7495, except as specified in paragraph (j) of this section. You must complete the one-time energy assessment specified in Table 3 to this subpart no later than the compliance date specified in §63.7495.

(f) - (i) Not applicable.

(j) For existing affected sources (as defined in §63.7490) that have not operated between the effective date of the rule and the compliance date that is specified for your source in §63.7495, you must complete the initial compliance demonstration, if subject to the emission limits in Table 2 to this subpart, as specified in paragraphs (a) through (d) of this section, no later than 180 days after the re-start of the affected source and according to the applicable provisions in §63.7(a)(2) as cited in Table 10 to this subpart. You must complete an initial tune-up by following the procedures described in §63.7540(a)(10)(i) through (vi) no later than 30 days after the re-start of the affected source and, if applicable, complete the one-time energy assessment specified in Table 3 to this subpart, no later than the compliance date specified in §63.7495.

**SECTION E. Source Group Restrictions.**

(k) Not applicable.

008 [40 CFR Part 63 NESHAPS for Source Categories §40 CFR 63.7515]

Subpart DDDDD - National Emission Standards for Hazardous Air Pollutants for Major Sources: Industrial, Commercial and Institutional Boilers and Process Heaters.

When must I conduct subsequent performance tests or fuel analyses, or tune-ups?

(a)-(c) Not applicable.

(d) If you are required to meet an applicable tune-up work practice standard, you must conduct an annual, biennial, or 5-year performance tune-up according to §63.7540(a)(10), (11), or (12), respectively. Each annual tune-up specified in §63.7540(a)(10) must be no more than 13 months after the previous tune-up. Each biennial tune-up specified in §63.7540(a)(11) must be conducted no more than 25 months after the previous tune-up. Each 5-year tune-up specified in §63.7540(a)(12) must be conducted no more than 61 months after the previous tune-up. For a new or reconstructed affected source (as defined in §63.7490), the first annual, biennial, or 5-year tune-up must be no later than 13 months, 25 months, or 61 months, respectively, after April 1, 2013 or the initial startup of the new or reconstructed affected source, whichever is later.

(e)-(i) Not applicable.

[Keystone is required to meet 5 year tune-up work practice standards according to §63.7540(a)(10). Annual and biennial performance tune-up work practice standards are not applicable.]

009 [40 CFR Part 63 NESHAPS for Source Categories §40 CFR 63.7540]

Subpart DDDDD - National Emission Standards for Hazardous Air Pollutants for Major Sources: Industrial, Commercial and Institutional Boilers and Process Heaters.

How do I demonstrate continuous compliance with the emission limitations, fuel specifications and work practice standards?

(a) You must demonstrate continuous compliance with each emission limit in Tables 1 and 2 or 11 through 13 to this subpart, the work practice standards in Table 3 to this subpart, and the operating limits in Table 4 to this subpart that applies to you according to the methods specified in Table 8 to this subpart and paragraphs (a)(1) through (19) of this section.

(1)-(9) Not applicable.

(10) If your boiler or process heater has a heat input capacity of 10 million Btu per hour or greater, you must conduct an annual tune-up of the boiler or process heater to demonstrate continuous compliance as specified in paragraphs (a)(10)(i) through (vi) of this section. You must conduct the tune-up while burning the type of fuel (or fuels in case of units that routinely burn a mixture) that provided the majority of the heat input to the boiler or process heater over the 12 months prior to the tune-up. This frequency does not apply to limited-use boilers and process heaters, as defined in §63.7575, or units with continuous oxygen trim systems that maintain an optimum air to fuel ratio.

(i) As applicable, inspect the burner, and clean or replace any components of the burner as necessary (you may perform the burner inspection any time prior to the tune-up or delay the burner inspection until the next scheduled unit shutdown). Units that produce electricity for sale may delay the burner inspection until the first outage, not to exceed 36 months from the previous inspection. At units where entry into a piece of process equipment or into a storage vessel is required to complete the tune-up inspections, inspections are required only during planned entries into the storage vessel or process equipment;

(ii) Inspect the flame pattern, as applicable, and adjust the burner as necessary to optimize the flame pattern. The adjustment should be consistent with the manufacturer's specifications, if available;

(iii) Inspect the system controlling the air-to-fuel ratio, as applicable, and ensure that it is correctly calibrated and functioning properly (you may delay the inspection until the next scheduled unit shutdown). Units that produce electricity for sale may delay the inspection until the first outage, not to exceed 36 months from the previous inspection;

(iv) Optimize total emissions of CO. This optimization should be consistent with the manufacturer's specifications, if

**SECTION E. Source Group Restrictions.**

available, and with any NOX requirement to which the unit is subject;

(v) Measure the concentrations in the effluent stream of CO in parts per million, by volume, and oxygen in volume percent, before and after the adjustments are made (measurements may be either on a dry or wet basis, as long as it is the same basis before and after the adjustments are made). Measurements may be taken using a portable CO analyzer; and

(vi) Maintain on-site and submit, if requested by the Administrator, a report containing the information in paragraphs (a)(10)(vi)(A) through (C) of this section,

(A) The concentrations of CO in the effluent stream in parts per million by volume, and oxygen in volume percent, measured at high fire or typical operating load, before and after the tune-up of the boiler or process heater;

(B) A description of any corrective actions taken as a part of the tune-up; and

(C) The type and amount of fuel used over the 12 months prior to the tune-up, but only if the unit was physically and legally capable of using more than one type of fuel during that period. Units sharing a fuel meter may estimate the fuel used by each unit.

(11)-(12) Not applicable.

(13) If the unit is not operating on the required date for a tune-up, the tune-up must be conducted within 30 calendar days of startup.

(14) - (19) Not applicable.

(b) – (d) Not applicable.

010 [40 CFR Part 63 NESHAPS for Source Categories §40 CFR 63.7545]

Subpart DDDDD - National Emission Standards for Hazardous Air Pollutants for Major Sources: Industrial, Commercial and Institutional Boilers and Process Heaters.

What notifications must I submit and when?

(a) You must submit to the Administrator all of the notifications in §§ 63.7(b) and (c), 63.8(e), (f)(4) and (6), and 63.9(b) through (h) that apply to you by the dates specified.

(b) - (c) Not applicable.

(d) If you are required to conduct a performance test you must submit a Notification of Intent to conduct a performance test at least 60 days before the performance test is scheduled to begin.

(e) – (h) Not applicable.

011 [40 CFR Part 63 NESHAPS for Source Categories §40 CFR 63.7550]

Subpart DDDDD - National Emission Standards for Hazardous Air Pollutants for Major Sources: Industrial, Commercial and Institutional Boilers and Process Heaters.

What reports must I submit and when?

(a) You must submit each report in Table 9 to this subpart that applies to you.

(b) Unless the EPA Administrator has approved a different schedule for submission of reports under §63.10(a), you must submit each report, according to paragraph (h) of this section, by the date in Table 9 to this subpart and according to the requirements in paragraphs (b)(1) through (4) of this section. For units that are subject only to a requirement to conduct subsequent annual, biennial, or 5-year tune-up according to §63.7540(a)(10), (11), or (12), respectively, and not subject to emission limits or Table 4 operating limits, you may submit only an annual, biennial, or 5-year compliance report, as applicable, as specified in paragraphs (b)(1) through (4) of this section, instead of a semi-annual compliance report.

(1) The first semi-annual compliance report must cover the period beginning on the compliance date that is specified for each boiler or process heater in §63.7495 and ending on June 30 or December 31, whichever date is the first date that occurs at least 180 days after the compliance date that is specified for your source in §63.7495. If submitting an annual, biennial, or 5-year compliance report, the first compliance report must cover the period beginning on the compliance date

**SECTION E. Source Group Restrictions.**

that is specified for each boiler or process heater in §63.7495 and ending on December 31 within 1, 2, or 5 years, as applicable, after the compliance date that is specified for your source in §63.7495.

(2) The first semi-annual compliance report must be postmarked or submitted no later than July 31 or January 31, whichever date is the first date following the end of the first calendar half after the compliance date that is specified for each boiler or process heater in §63.7495. The first annual, biennial, or 5-year compliance report must be postmarked or submitted no later than January 31.

(3) Each subsequent semi-annual compliance report must cover the semiannual reporting period from January 1 through June 30 or the semiannual reporting period from July 1 through December 31. Annual, biennial, and 5-year compliance reports must cover the applicable 1-, 2-, or 5-year periods from January 1 to December 31.

(4) Each subsequent compliance report must be postmarked or submitted no later than July 31 or January 31, whichever date is the first date following the end of the semiannual reporting period. Annual, biennial, and 5-year compliance reports must be postmarked or submitted no later than January 31.

(c) A compliance report must contain the following information depending on how the facility chooses to comply with the limits set in this rule.

(1) If the facility is subject to the requirements of a tune up you must submit a compliance report with the information in paragraphs (c)(5)(i) through (iii) of this section, (xiv) and (xvii) of this section, and paragraph (c)(5)(iv) of this section for limited-use boiler or process heater.

(2) – (4) Not applicable.

(5)(i) Company and Facility name and address.

(ii) Process unit information, emissions limitations, and operating parameter limitations.

(iii) Date of report and beginning and ending dates of the reporting period.

(iv) The total operating time during the reporting period.

(v) – (xiii) Not applicable.

(xiv) Include the date of the most recent tune-up for each unit subject to only the requirement to conduct an annual, biennial, or 5-year tune-up according to §63.7540(a)(10), (11), or (12) respectively. Include the date of the most recent burner inspection if it was not done annually, biennially, or on a 5-year period and was delayed until the next scheduled or unscheduled unit shutdown.

(xv) - (xvi) Not applicable.

(xvii) Statement by a responsible official with that official's name, title, and signature, certifying the truth, accuracy, and completeness of the content of the report.

(xviii) For each instance of startup or shutdown include the information required to be monitored, collected, or recorded according to the requirements of §63.7555(d).

(d) - (e) Not applicable.

(f)-(g) [Reserved]

(h) You must submit the reports according to the procedures specified in paragraphs (h)(1) through (3) of this section.

(1) - (2) Not applicable.

(3) You must submit all reports required by Table 9 of this subpart electronically to the EPA via the CEDRI. (CEDRI can be

**SECTION E. Source Group Restrictions.**

accessed through the EPA's CDX.) You must use the appropriate electronic report in CEDRI for this subpart. Instead of using the electronic report in CEDRI for this subpart, you may submit an alternate electronic file consistent with the XML schema listed on the CEDRI Web site (<http://www.epa.gov/ttn/chief/cedri/index.html>), once the XML schema is available. If the reporting form specific to this subpart is not available in CEDRI at the time that the report is due, you must submit the report to the Administrator at the appropriate address listed in §63.13. You must begin submitting reports via CEDRI no later than 90 days after the form becomes available in CEDRI.

(Table 9 states; You must submit a Compliance report. The report must contain:

- a. Information required in § 63.7550(c)(1) through (5); and
- b. If there are no deviations from any emission limitation (emission limit and operating limit) that applies to you and there are no deviations from the requirements for work practice standards for periods of startup and shutdown in Table 3 to this subpart that apply to you, a statement that there were no deviations from the emission limitations and work practice standards during the reporting period. If there were no periods during which the CMSs, including continuous emissions monitoring system, continuous opacity monitoring system, and operating parameter monitoring systems, were out-of-control as specified in §63.8(c)(7), a statement that there were no periods during which the CMSs were out-of-control during the reporting period; and
- c. If you have a deviation from any emission limitation (emission limit and operating limit) where you are not using a CMS to comply with that emission limit or operating limit, or a deviation from a work practice standard for periods of startup and shutdown, during the reporting period, the report must contain the information in §63.7550(d); and
- d. If there were periods during which the CMSs, including continuous emissions monitoring system, continuous opacity monitoring system, and operating parameter monitoring systems, were out-of-control as specified in §63.8(c)(7), or otherwise not operating, the report must contain the information in §63.7550(e)

You must submit the report semiannually, annually, biennially, or every 5 years according to the requirements in §63.7550(b).

012 [40 CFR Part 63 NESHAPS for Source Categories §40 CFR 63.7555]**Subpart DDDDD - National Emission Standards for Hazardous Air Pollutants for Major Sources: Industrial, Commercial and Institutional Boilers and Process Heaters.****What records must I keep?**

(a) You must keep records according to paragraphs (a)(1) and (2) of this section.

(1) A copy of each notification and report that you submitted to comply with this subpart, including all documentation supporting any Initial Notification or Notification of Compliance Status or semiannual compliance report that you submitted, according to the requirements in §63.10(b)(2)(xiv).

(2) Not applicable.

(3) For units in the limited use subcategory, you must keep a copy of the federally enforceable permit that limits the annual capacity factor to less than or equal to 10 percent and fuel use records for the days the boiler or process heater was operating.

(b) - (h) Not applicable.

013 [40 CFR Part 63 NESHAPS for Source Categories §40 CFR 63.7560]**Subpart DDDDD - National Emission Standards for Hazardous Air Pollutants for Major Sources: Industrial, Commercial and Institutional Boilers and Process Heaters.****In what form and how long must I keep my records?**

(a) Your records must be in a form suitable and readily available for expeditious review, according to § 63.10(b)(1).

(b) As specified in § 63.10(b)(1), you must keep each record for 5 years following the date of each occurrence, measurement, maintenance, corrective action, report, or record.

(c) You must keep each record on site, or they must be accessible from on site (for example, through a computer network),

**SECTION E. Source Group Restrictions.**

for at least 2 years after the date of each occurrence, measurement, maintenance, corrective action, report, or record, according to § 63.10(b)(1). You can keep the records off site for the remaining 3 years.

014 [40 CFR Part 63 NESHAPS for Source Categories §40 CFR 63.7575]**Subpart DDDDD - National Emission Standards for Hazardous Air Pollutants for Major Sources: Industrial, Commercial and Institutional Boilers and Process Heaters.****What definitions apply to this subpart?**

Terms used in this subpart are defined in the Clean Air Act, in § 63.2 (the General Provisions), and in this section as follows:

Annual capacity factor means the ratio between the actual heat input to a boiler or process heater from the fuels burned during a calendar year and the potential heat input to the boiler or process heater had it been operated for 8,760 hours during a year at the maximum steady state design heat input capacity.

Annual heat input means the heat input for the 12 months preceding the compliance demonstration.

Average annual heat input rate means total heat input divided by the hours of operation for the 12 months preceding the compliance demonstration.

Distillate oil means fuel oils that contain 0.05 weight percent nitrogen or less and comply with the specifications for fuel oil numbers 1 and 2, as defined by the American Society of Testing and Materials in ASTM D396 (incorporated by reference, see §63.14) or diesel fuel oil numbers 1 and 2, as defined by the American Society for Testing and Materials in ASTM D975 (incorporated by reference, see §63.14), kerosene, and biodiesel as defined by the American Society of Testing and Materials in ASTM D6751-11b (incorporated by reference, see §60.14).

Heat input means heat derived from combustion of fuel in a boiler or process heater and does not include the heat input from preheated combustion air, recirculated flue gases, returned condensate, or exhaust gases from other sources such as gas turbines, internal combustion engines, kilns, etc.

Industrial boiler means a boiler used in manufacturing, processing, mining, and refining or any other industry to provide steam, hot water, and/or electricity.

Light liquid includes distillate oil, biodiesel, or vegetable oil.

Limited-use boiler or process heater means any boiler or process heater that burns any amount of solid, liquid, or gaseous fuels and has a federally enforceable annual capacity factor of no more than 10 percent.

Liquid fuel includes, but is not limited to, light liquid, heavy liquid, any form of liquid fuel derived from petroleum, used oil, liquid biofuels, biodiesel, and vegetable oil.

Load fraction means the actual heat input of a boiler or process heater divided by heat input during the performance test that established the minimum sorbent injection rate or minimum activated carbon injection rate, expressed as a fraction (e.g., for 50 percent load the load fraction is 0.5). For boilers and process heaters that co-fire natural gas or refinery gas with a solid or liquid fuel, the load fraction is determined by the actual heat input of the solid or liquid fuel divided by heat input of the solid or liquid fuel fired during the performance test (e.g., if the performance test was conducted at 100 percent solid fuel firing, for 100 percent load firing 50 percent solid fuel and 50 percent natural gas the load fraction is 0.5).

Unit designed to burn light liquid subcategory means a unit in the unit designed to burn liquid subcategory that is not part of the unit designed to burn heavy liquid subcategory.

***** Permit Shield in Effect. *****

**SECTION E. Source Group Restrictions.**

Group Name: G05

Group Description: Peaking Diesel Engines Units 3, 4, 5, and 6

Sources included in this group

ID	Name
101	UNIT 3 PEAKING DIESEL GENERATOR (3,600-BHP)
102	UNIT 4 PEAKING DIESEL GENERATOR (3,600-BHP)
103	UNIT 5 PEAKING DIESEL GENERATOR (3,600-BHP)
104	UNIT 6 PEAKING DIESEL GENERATOR (3,600-BHP)

I. RESTRICTIONS.**Emission Restriction(s).**

001 [25 Pa. Code §123.13]

Processes

In accordance with 25 Pa. Code §123.13(c)(1)(i), the permittee may not permit the emission into the outdoor atmosphere of particulate matter from this source in a manner that the concentration of particulate matter in the effluent gas exceeds 0.04 grain per dry standard cubic foot.

002 [25 Pa. Code §123.21]

General

The permittee shall not allow emissions of sulfur oxides from each engine in such a manner that the concentration of sulfur oxides, expressed as SO₂, in the effluent gas exceeds 500 parts per million by volume, dry basis.

Operation Hours Restriction(s).

003 [25 Pa. Code §127.441]

Operating permit terms and conditions.

In accordance with RACT Operating Permit No. 03-000-027, operation of Diesel Generators 3-6 shall each not exceed a 5% annual heat input capacity factor. These units shall be operated and maintained in accordance with manufacturers' specifications, and good air pollution control and engineering practices. (25 Pa. Code §127.441)

(Compliance with this condition is assured by meeting Condition 004)

II. TESTING REQUIREMENTS.

No additional testing requirements exist except as provided in other sections of this permit including Section B (Title V General Requirements).

III. MONITORING REQUIREMENTS.

No additional monitoring requirements exist except as provided in other sections of this permit including Section B (Title V General Requirements).

IV. RECORDKEEPING REQUIREMENTS.

004 [25 Pa. Code §127.441]

Operating permit terms and conditions.

The permittee shall maintain an operating log, including records of hours of operation, fuel consumption, fuel type, and typical fuel analyses that verify compliance with the annual operational limitations.

V. REPORTING REQUIREMENTS.

No additional reporting requirements exist except as provided in other sections of this permit including Section B (Title V General Requirements).

**SECTION E. Source Group Restrictions.****VI. WORK PRACTICE REQUIREMENTS.****# 005 [25 Pa. Code §129.97]****Presumptive RACT requirements, RACT emission limitations and petition for alternative compliance schedule.**

The permittee shall install, maintain, and operate Peaking Diesel Engines 3-6 in accordance with the manufacturer's specifications and with good operating practices.

VII. ADDITIONAL REQUIREMENTS.**# 006 [25 Pa. Code §127.441]****Operating permit terms and conditions.**

The permittee shall verify compliance with the particulate mass emission rate of 25 PA Code §123.13, opacity standards of §123.41, and SO₂ limitations of §123.21 through the operation and maintenance of these sources in accordance with manufacturer specifications.

007 [40 CFR Part 63 NESHAPS for Source Categories §40 CFR 63.6590]**Subpart ZZZZ - National Emissions Standards for Hazardous Air Pollutants for Stationary Reciprocating Internal Combustion Engines****What parts of my plant does this subpart cover?**

(a) Affected source. An affected source is any existing, new, or reconstructed stationary RICE located at a major or area source of HAP emissions, excluding stationary RICE being tested at a stationary RICE test cell/stand.

(1) Existing stationary RICE.

(i) For stationary RICE with a site rating of more than 500 brake horsepower (HP) located at a major source of HAP emissions, a stationary RICE is existing if you commenced construction or reconstruction of the stationary RICE before December 19, 2002.

(ii) – (iv) N/A.

(2) – (3) N/A.

(b) Stationary RICE subject to limited requirements. (1) An affected source which meets either of the criteria in paragraphs (b)(1)(i) through (ii) of this section does not have to meet the requirements of this subpart and of subpart A of this part except for the initial notification requirements of § 63.6645(f).

(1) – (2) N/A.

(3) The following stationary RICE do not have to meet the requirements of this subpart and of subpart A of this part, including initial notification requirements:

(i) – (iii) N/A.

(iv) Existing limited use stationary RICE with a site rating of more than 500 brake HP located at a major source of HAP emissions;

(v) N/A.

(c) N/A.

[Peaking Diesel Engines 3, 4, 5, and 6 (Source IDs 101, 102, 103, and 104) are subject to the applicable requirements of 40 CFR Part 60, Subpart ZZZZ.]

008 [40 CFR Part 63 NESHAPS for Source Categories §40 CFR 63.6675]**Subpart ZZZZ - National Emissions Standards for Hazardous Air Pollutants for Stationary Reciprocating Internal Combustion Engines****What definitions apply to this subpart?**

Terms used in this subpart (40 CFR Part 63, Subpart ZZZZ) are defined in the Clean Air Act (CAA); in 40 CFR 63.2, the General Provisions of this part; (40 CFR Part 63) and in this section as follows:

**SECTION E. Source Group Restrictions.**

Limited use stationary RICE means any stationary RICE that operates less than 100 hours per year.

***** Permit Shield in Effect. *****



SECTION E. Source Group Restrictions.

Group Name: G06
Group Description: [Reserved]
[Sources included in this group](#)

ID	Name
----	------

No Sources exist for this Group.

I. RESTRICTIONS.

No additional requirements exist except as provided in other sections of this permit including Section B (Title V General Requirements).

II. TESTING REQUIREMENTS.

No additional testing requirements exist except as provided in other sections of this permit including Section B (Title V General Requirements).

III. MONITORING REQUIREMENTS.

No additional monitoring requirements exist except as provided in other sections of this permit including Section B (Title V General Requirements).

IV. RECORDKEEPING REQUIREMENTS.

No additional record keeping requirements exist except as provided in other sections of this permit including Section B (Title V General Requirements).

V. REPORTING REQUIREMENTS.

No additional reporting requirements exist except as provided in other sections of this permit including Section B (Title V General Requirements).

VI. WORK PRACTICE REQUIREMENTS.

No additional work practice requirements exist except as provided in other sections of this permit including Section B (Title V General Requirements).

VII. ADDITIONAL REQUIREMENTS.

No additional requirements exist except as provided in other sections of this permit including Section B (Title V General Requirements).

***** Permit Shield in Effect. *****

**SECTION E. Source Group Restrictions.**

Group Name: G07

Group Description: Part 63 Subpart UUUUU

Sources included in this group

ID	Name
031	BOILER 1 WITH LOW NOX BURNER
032	BOILER 2 WITH LOW NOX BURNER

I. RESTRICTIONS.**Emission Restriction(s).****# 001 [40 CFR Part 63 NESHAPS for Source Categories §40 CFR subpart 63.9991]****SUBPART UUUUU - National Emission Standards for Hazardous Air Pollutants: Coal- and Oil-Fired Electric Utility Steam Generating Units****What emission limitations, work practice standards, and operating limits must I meet?**

(a) You must meet the requirements in paragraphs (a)(1) and (2) of this section. You must meet these requirements at all times.

(1) You must meet each emission limit and work practice standard in Table 1 through 3 to this subpart that applies to your EGU, for each EGU at your source, except as provided under §63.10009.

(2) Not applicable.

(b) As provided in §63.6(g), the Administrator may approve use of an alternative to the work practice standards in this section.

(c) You may use the alternate SO₂ limit in Tables 1 and 2 to this subpart only if your EGU:

(1) Has a system using wet or dry flue gas desulfurization technology and an SO₂ continuous emissions monitoring system (CEMS) installed on the EGU; and

(2) At all times, you operate the wet or dry flue gas desulfurization technology and the SO₂ CEMS installed on the EGU consistent with §63.10000(b).

002 [40 CFR Part 63 NESHAPS for Source Categories §Table 2 to Subpart UUUUU of Part 63]**SUBPART UUUUU - National Emission Standards for Hazardous Air Pollutants: Coal- and Oil-Fired Electric Utility Steam Generating Units****Emission Limits for Existing EGUs**

As stated in §63.9991, you must comply with the following applicable emission limits:[1]

(1) For Coal-fired units not low rank virgin coal, you must meet the following emission limits and work practice standards:
 (a) Filterable particulate matter (PM)- the emission limit of 3.0E-2 lb/MMBtu or 3.0E-1 lb/MWh[2] and collect a minimum of 1 dscm per run in accordance with the test methods in Table 5 of this Subpart.

OR

Total non-Hg HAP metals- the emission limit of 5.0E-5 lb/MMBtu or 5.0E-1 lb/GWh and collect a minimum of 1 dscm per run in accordance with the test methods in Table 5 of this Subpart.

OR

Individual HAP metals collecting a minimum of 3 dscm per run in accordance with the test methods in Table 5 of this Subpart:

- Antimony (Sb)- emission limit of 8.0E-1 lb/TBtu or 8.0E-3 lb/GWh
- Arsenic (As)- emission limit of 1.1E0 lb/TBtu or 2.0E-2 lb/GWh
- Beryllium (Be)- emission limit of 2.0E-1 lb/TBtu or 2.0E-3 lb/GWh
- Cadmium (Cd)- emission limit of 3.0E-1 lb/TBtu or 3.0E-3 lb/GWh
- Chromium (Cr)- emission limit of 2.8E0 lb/TBtu or 3.0E-2 lb/GWh
- Cobalt (Co)- emission limit of 8.0E-1 lb/TBtu or 8.0E-3 lb/GWh
- Lead (Pb)- emission limit of 1.2E0 lb/TBtu or 2.0E-2 lb/GWh
- Manganese (Mn)- emission limit of 4.0E0 lb/TBtu or 5.0E-2 lb/GWh
- Nickel (Ni)- emission limit of 3.5E0 lb/TBtu or 4.0E-2 lb/GWh

**SECTION E. Source Group Restrictions.**

Selenium (Se)-emission limit of 5.0E0 lb/TBtu or 6.0E-2 lb/GWh

(b) Hydrogen chloride (HCl)- emission limit of 2.0E-3 lb/MMBtu or 2.0E-2 lb/MWh for Method 26A at appendix A-8 to part 60 of this chapter, collect a minimum of 0.75 dscm per run; for Method 26, collect a minimum of 120 liters per run. For ASTM D6348-03[3] or Method 320 at appendix A to part 63 of this chapter, sample for a minimum of 1 hour.

OR

Sulfur dioxide (SO₂)[4]- emission limit of 2.0E-1 lb/MMBtu or 1.5E0 lb/MWh SO₂ CEMS.

(c) Mercury (Hg)- emission limit of 1.2E0 lb/TBtu or 1.3E-2 lb/GWh, LEE Testing for 30 days with a sampling period consistent with that given in section 5.2.1 of appendix A to this subpart per Method 30B at appendix A-8 to part 60 of this chapter run or Hg CEMS or sorbent trap monitoring system only.

OR

Mercury (Hg)- emission limit of 1.0E0 lb/TBtu or 1.1E-2 lb/GWh, LEE Testing for 90 days with a sampling period consistent with that given in section 5.2.1 of appendix A to this subpart per Method 30B run or Hg CEMS or sorbent trap monitoring system only.

[1]For LEE emissions testing for total PM, total HAP metals, individual HAP metals, HCl, and HF, the required minimum sampling volume must be increased nominally by a factor of two.

[2]Gross output.

[3]Incorporated by reference, see §63.14.

[4]You may not use the alternate SO₂ limit if your EGU does not have some form of FGD system and SO₂ CEMS installed.

II. TESTING REQUIREMENTS.**# 003 [40 CFR Part 63 NESHAPS for Source Categories §40 CFR 63.7]****Subpart A--General Provisions****Performance testing requirements.**

(a) Applicability and performance test dates. (1) The applicability of this section is set out in §63.1(a)(4).

(2) Except as provided in paragraph (a)(4) of this section, if required to do performance testing by a relevant standard, and unless a waiver of performance testing is obtained under this section or the conditions of paragraph (c)(3)(ii)(B) of this section apply, the owner or operator of the affected source must perform such tests within 180 days of the compliance date for such source.

(i)-(viii) [Reserved]

(ix) Except as provided in paragraph (a)(4) of this section, when an emission standard promulgated under this part is more stringent than the standard proposed (see §63.6(b)(3)), the owner or operator of a new or reconstructed source subject to that standard for which construction or reconstruction is commenced between the proposal and promulgation dates of the standard shall comply with performance testing requirements within 180 days after the standard's effective date, or within 180 days after startup of the source, whichever is later. If the promulgated standard is more stringent than the proposed standard, the owner or operator may choose to demonstrate compliance with either the proposed or the promulgated standard. If the owner or operator chooses to comply with the proposed standard initially, the owner or operator shall conduct a second performance test within 3 years and 180 days after the effective date of the standard, or after startup of the source, whichever is later, to demonstrate compliance with the promulgated standard.

(3) The Administrator may require an owner or operator to conduct performance tests at the affected source at any other time when the action is authorized by section 114 of the Act.

(4) If a force majeure is about to occur, occurs, or has occurred for which the affected owner or operator intends to assert a claim of force majeure:

(i) The owner or operator shall notify the Administrator, in writing as soon as practicable following the date the owner or operator first knew, or through due diligence should have known that the event may cause or caused a delay in testing beyond the regulatory deadline specified in paragraph (a)(2) or (a)(3) of this section, or elsewhere in this part, but the

**SECTION E. Source Group Restrictions.**

notification must occur before the performance test deadline unless the initial force majeure or a subsequent force majeure event delays the notice, and in such cases, the notification shall occur as soon as practicable.

(ii) The owner or operator shall provide to the Administrator a written description of the force majeure event and a rationale for attributing the delay in testing beyond the regulatory deadline to the force majeure; describe the measures taken or to be taken to minimize the delay; and identify a date by which the owner or operator proposes to conduct the performance test. The performance test shall be conducted as soon as practicable after the force majeure occurs.

(iii) The decision as to whether or not to grant an extension to the performance test deadline is solely within the discretion of the Administrator. The Administrator will notify the owner or operator in writing of approval or disapproval of the request for an extension as soon as practicable.

(iv) Until an extension of the performance test deadline has been approved by the Administrator under paragraphs (a)(4)(i), (a)(4)(ii), and (a)(4)(iii) of this section, the owner or operator of the affected facility remains strictly subject to the requirements of this part.

(b) Notification of performance test. (1) The owner or operator of an affected source must notify the Administrator in writing of his or her intention to conduct a performance test at least 60 calendar days before the performance test is initially scheduled to begin to allow the Administrator, upon request, to review and approve the site-specific test plan required under paragraph (c) of this section and to have an observer present during the test.

(2) In the event the owner or operator is unable to conduct the performance test on the date specified in the notification requirement specified in paragraph (b)(1) of this section due to unforeseeable circumstances beyond his or her control, the owner or operator must notify the Administrator as soon as practicable and without delay prior to the scheduled performance test date and specify the date when the performance test is rescheduled. This notification of delay in conducting the performance test shall not relieve the owner or operator of legal responsibility for compliance with any other applicable provisions of this part or with any other applicable Federal, State, or local requirement, nor will it prevent the Administrator from implementing or enforcing this part or taking any other action under the Act.

(c) Quality assurance program. (1) The results of the quality assurance program required in this paragraph will be considered by the Administrator when he/she determines the validity of a performance test.

(2)(i) Submission of site-specific test plan. Before conducting a required performance test, the owner or operator of an affected source shall develop and, if requested by the Administrator, shall submit a site-specific test plan to the Administrator for approval. The test plan shall include a test program summary, the test schedule, data quality objectives, and both an internal and external quality assurance (QA) program. Data quality objectives are the pretest expectations of precision, accuracy, and completeness of data.

(ii) The internal QA program shall include, at a minimum, the activities planned by routine operators and analysts to provide an assessment of test data precision; an example of internal QA is the sampling and analysis of replicate samples.

(iii) The performance testing shall include a test method performance audit (PA) during the performance test. The PAs consist of blind audit samples supplied by an accredited audit sample provider and analyzed during the performance test in order to provide a measure of test data bias. Gaseous audit samples are designed to audit the performance of the sampling system as well as the analytical system and must be collected by the sampling system during the compliance test just as the compliance samples are collected. If a liquid or solid audit sample is designed to audit the sampling system, it must also be collected by the sampling system during the compliance test. If multiple sampling systems or sampling trains are used during the compliance test for any of the test methods, the tester is only required to use one of the sampling systems per method to collect the audit sample. The audit sample must be analyzed by the same analyst using the same analytical reagents and analytical system and at the same time as the compliance samples. Retests are required when there is a failure to produce acceptable results for an audit sample. However, if the audit results do not affect the compliance or noncompliance status of the affected facility, the compliance authority may waive the reanalysis requirement, further audits, or retests and accept the results of the compliance test. Acceptance of the test results shall constitute a waiver of the reanalysis requirement, further audits, or retests. The compliance authority may also use the audit sample failure and the compliance test results as evidence to determine the compliance or noncompliance status of the affected facility. A blind audit sample is a sample whose value is known only to the sample provider and is not revealed to the tested facility until after they report the measured value of the audit sample. For pollutants that exist in the gas phase at ambient

**SECTION E. Source Group Restrictions.**

temperature, the audit sample shall consist of an appropriate concentration of the pollutant in air or nitrogen that can be introduced into the sampling system of the test method at or near the same entry point as a sample from the emission source. If no gas phase audit samples are available, an acceptable alternative is a sample of the pollutant in the same matrix that would be produced when the sample is recovered from the sampling system as required by the test method. For samples that exist only in a liquid or solid form at ambient temperature, the audit sample shall consist of an appropriate concentration of the pollutant in the same matrix that would be produced when the sample is recovered from the sampling system as required by the test method. An accredited audit sample provider (AASP) is an organization that has been accredited to prepare audit samples by an independent, third party accrediting body.

(A) The source owner, operator, or representative of the tested facility shall obtain an audit sample, if commercially available, from an AASP for each test method used for regulatory compliance purposes. No audit samples are required for the following test methods: Methods 3A and 3C of appendix A-3 of part 60 of this chapter; Methods 6C, 7E, 9, and 10 of appendix A-4 of part 60; Methods 18 and 19 of appendix A-6 of part 60; Methods 20, 22, and 25A of appendix A-7 of part 60; Methods 30A and 30B of appendix A-8 of part 60; and Methods 303, 318, 320, and 321 of appendix A of this part. If multiple sources at a single facility are tested during a compliance test event, only one audit sample is required for each method used during a compliance test. The compliance authority responsible for the compliance test may waive the requirement to include an audit sample if they believe that an audit sample is not necessary. "Commercially available" means that two or more independent AASPs have blind audit samples available for purchase. If the source owner, operator, or representative cannot find an audit sample for a specific method, the owner, operator, or representative shall consult the EPA Web site at the following URL, www.epa.gov/ttn/emc, to confirm whether there is a source that can supply an audit sample for that method. If the EPA Web site does not list an available audit sample at least 60 days prior to the beginning of the compliance test, the source owner, operator, or representative shall not be required to include an audit sample as part of the quality assurance program for the compliance test. When ordering an audit sample, the source owner, operator, or representative shall give the sample provider an estimate for the concentration of each pollutant that is emitted by the source or the estimated concentration of each pollutant based on the permitted level and the name, address, and phone number of the compliance authority. The source owner, operator, or representative shall report the results for the audit sample along with a summary of the emission test results for the audited pollutant to the compliance authority and shall report the results of the audit sample to the AASP. The source owner, operator, or representative shall make both reports at the same time and in the same manner or shall report to the compliance authority first and then report to the AASP. If the method being audited is a method that allows the samples to be analyzed in the field and the tester plans to analyze the samples in the field, the tester may analyze the audit samples prior to collecting the emission samples provided a representative of the compliance authority is present at the testing site. The tester may request, and the compliance authority may grant, a waiver to the requirement that a representative of the compliance authority must be present at the testing site during the field analysis of an audit sample. The source owner, operator, or representative may report the results of the audit sample to the compliance authority and then report the results of the audit sample to the AASP prior to collecting any emission samples. The test protocol and final test report shall document whether an audit sample was ordered and utilized and the pass/fail results as applicable.

(B)-(D) Not applicable.

(iv) The owner or operator of an affected source shall submit the site-specific test plan to the Administrator upon the Administrator's request at least 60 calendar days before the performance test is scheduled to take place, that is, simultaneously with the notification of intention to conduct a performance test required under paragraph (b) of this section, or on a mutually agreed upon date.

(v) The Administrator may request additional relevant information after the submittal of a site-specific test plan.

(3) Approval of site-specific test plan. (i) The Administrator will notify the owner or operator of approval or intention to deny approval of the site-specific test plan (if review of the site-specific test plan is requested) within 30 calendar days after receipt of the original plan and within 30 calendar days after receipt of any supplementary information that is submitted under paragraph (c)(3)(i)(B) of this section. Before disapproving any site-specific test plan, the Administrator will notify the applicant of the Administrator's intention to disapprove the plan together with—

(A) Notice of the information and findings on which the intended disapproval is based; and

(B) Notice of opportunity for the owner or operator to present, within 30 calendar days after he/she is notified of the intended disapproval, additional information to the Administrator before final action on the plan.

**SECTION E. Source Group Restrictions.**

(ii) In the event that the Administrator fails to approve or disapprove the site-specific test plan within the time period specified in paragraph (c)(3)(i) of this section, the following conditions shall apply:

(A) If the owner or operator intends to demonstrate compliance using the test method(s) specified in the relevant standard or with only minor changes to those tests methods (see paragraph (e)(2)(i) of this section), the owner or operator must conduct the performance test within the time specified in this section using the specified method(s);

(B) If the owner or operator intends to demonstrate compliance by using an alternative to any test method specified in the relevant standard, the owner or operator is authorized to conduct the performance test using an alternative test method after the Administrator approves the use of the alternative method when the Administrator approves the site-specific test plan (if review of the site-specific test plan is requested) or after the alternative method is approved (see paragraph (f) of this section). However, the owner or operator is authorized to conduct the performance test using an alternative method in the absence of notification of approval 45 days after submission of the site-specific test plan or request to use an alternative method. The owner or operator is authorized to conduct the performance test within 60 calendar days after he/she is authorized to demonstrate compliance using an alternative test method. Notwithstanding the requirements in the preceding three sentences, the owner or operator may proceed to conduct the performance test as required in this section (without the Administrator's prior approval of the site-specific test plan) if he/she subsequently chooses to use the specified testing and monitoring methods instead of an alternative.

(iii) Neither the submission of a site-specific test plan for approval, nor the Administrator's approval or disapproval of a plan, nor the Administrator's failure to approve or disapprove a plan in a timely manner shall—

(A) Relieve an owner or operator of legal responsibility for compliance with any applicable provisions of this part or with any other applicable Federal, State, or local requirement; or

(B) Prevent the Administrator from implementing or enforcing this part or taking any other action under the Act.

(d) Performance testing facilities. If required to do performance testing, the owner or operator of each new source and, at the request of the Administrator, the owner or operator of each existing source, shall provide performance testing facilities as follows:

(1) Sampling ports adequate for test methods applicable to such source. This includes:

(i) Constructing the air pollution control system such that volumetric flow rates and pollutant emission rates can be accurately determined by applicable test methods and procedures; and

(ii) Providing a stack or duct free of cyclonic flow during performance tests, as demonstrated by applicable test methods and procedures;

(2) Safe sampling platform(s);

(3) Safe access to sampling platform(s);

(4) Utilities for sampling and testing equipment; and

(5) Any other facilities that the Administrator deems necessary for safe and adequate testing of a source.

(e) Conduct of performance tests. (1) Performance tests shall be conducted under such conditions as the Administrator specifies to the owner or operator based on representative performance (i.e., performance based on normal operating conditions) of the affected source. Operations during periods of startup, shutdown, and malfunction shall not constitute representative conditions for the purpose of a performance test, nor shall emissions in excess of the level of the relevant standard during periods of startup, shutdown, and malfunction be considered a violation of the relevant standard unless otherwise specified in the relevant standard or a determination of noncompliance is made under §63.6(e). Upon request, the owner or operator shall make available to the Administrator such records as may be necessary to determine the conditions of performance tests.

(2) Performance tests shall be conducted and data shall be reduced in accordance with the test methods and procedures

**SECTION E. Source Group Restrictions.**

set forth in this section, in each relevant standard, and, if required, in applicable appendices of parts 51, 60, 61, and 63 of this chapter unless the Administrator—

- (i) Specifies or approves, in specific cases, the use of a test method with minor changes in methodology (see definition in §63.90(a)). Such changes may be approved in conjunction with approval of the site-specific test plan (see paragraph (c) of this section); or
 - (ii) Approves the use of an intermediate or major change or alternative to a test method (see definitions in §63.90(a)), the results of which the Administrator has determined to be adequate for indicating whether a specific affected source is in compliance; or
 - (iii) Approves shorter sampling times or smaller sample volumes when necessitated by process variables or other factors; or
 - (iv) Waives the requirement for performance tests because the owner or operator of an affected source has demonstrated by other means to the Administrator's satisfaction that the affected source is in compliance with the relevant standard.
- (3) Unless otherwise specified in a relevant standard or test method, each performance test shall consist of three separate runs using the applicable test method. Each run shall be conducted for the time and under the conditions specified in the relevant standard. For the purpose of determining compliance with a relevant standard, the arithmetic mean of the results of the three runs shall apply. Upon receiving approval from the Administrator, results of a test run may be replaced with results of an additional test run in the event that—
- (i) A sample is accidentally lost after the testing team leaves the site; or
 - (ii) Conditions occur in which one of the three runs must be discontinued because of forced shutdown; or
 - (iii) Extreme meteorological conditions occur; or
 - (iv) Other circumstances occur that are beyond the owner or operator's control.
- (4) Nothing in paragraphs (e)(1) through (e)(3) of this section shall be construed to abrogate the Administrator's authority to require testing under section 114 of the Act.
- (f) Use of an alternative test method—(1)General. Until authorized to use an intermediate or major change or alternative to a test method, the owner or operator of an affected source remains subject to the requirements of this section and the relevant standard.
- (2) The owner or operator of an affected source required to do performance testing by a relevant standard may use an alternative test method from that specified in the standard provided that the owner or operator—
- (i) Notifies the Administrator of his or her intention to use an alternative test method at least 60 days before the performance test is scheduled to begin;
 - (ii) Uses Method 301 in appendix A of this part to validate the alternative test method. This may include the use of specific procedures of Method 301 if use of such procedures are sufficient to validate the alternative test method; and
 - (iii) Submits the results of the Method 301 validation process along with the notification of intention and the justification for not using the specified test method. The owner or operator may submit the information required in this paragraph well in advance of the deadline specified in paragraph (f)(2)(i) of this section to ensure a timely review by the Administrator in order to meet the performance test date specified in this section or the relevant standard.
- (3) The Administrator will determine whether the owner or operator's validation of the proposed alternative test method is adequate and issue an approval or disapproval of the alternative test method. If the owner or operator intends to demonstrate compliance by using an alternative to any test method specified in the relevant standard, the owner or operator is authorized to conduct the performance test using an alternative test method after the Administrator approves the use of the alternative method. However, the owner or operator is authorized to conduct the performance test using an alternative

**SECTION E. Source Group Restrictions.**

method in the absence of notification of approval/disapproval 45 days after submission of the request to use an alternative method and the request satisfies the requirements in paragraph (f)(2) of this section. The owner or operator is authorized to conduct the performance test within 60 calendar days after he/she is authorized to demonstrate compliance using an alternative test method. Notwithstanding the requirements in the preceding three sentences, the owner or operator may proceed to conduct the performance test as required in this section (without the Administrator's prior approval of the site-specific test plan) if he/she subsequently chooses to use the specified testing and monitoring methods instead of an alternative.

(4) If the Administrator finds reasonable grounds to dispute the results obtained by an alternative test method for the purposes of demonstrating compliance with a relevant standard, the Administrator may require the use of a test method specified in a relevant standard.

(5) If the owner or operator uses an alternative test method for an affected source during a required performance test, the owner or operator of such source shall continue to use the alternative test method for subsequent performance tests at that affected source until he or she receives approval from the Administrator to use another test method as allowed under §63.7(f).

(6) Neither the validation and approval process nor the failure to validate an alternative test method shall abrogate the owner or operator's responsibility to comply with the requirements of this part.

(g) Data analysis, recordkeeping, and reporting. (1) Unless otherwise specified in a relevant standard or test method, or as otherwise approved by the Administrator in writing, results of a performance test shall include the analysis of samples, determination of emissions, and raw data. A performance test is "completed" when field sample collection is terminated. The owner or operator of an affected source shall report the results of the performance test to the Administrator before the close of business on the 60th day following the completion of the performance test, unless specified otherwise in a relevant standard or as approved otherwise in writing by the Administrator (see §63.9(i)). The results of the performance test shall be submitted as part of the notification of compliance status required under §63.9(h). Before a title V permit has been issued to the owner or operator of an affected source, the owner or operator shall send the results of the performance test to the Administrator. After a title V permit has been issued to the owner or operator of an affected source, the owner or operator shall send the results of the performance test to the appropriate permitting authority.

(2) Contents of a performance test, CMS performance evaluation, or CMS quality assurance test report (electronic or paper submitted copy). Unless otherwise specified in a relevant standard, test method, CMS performance specification, or quality assurance requirement for a CMS, or as otherwise approved by the Administrator in writing, the report shall include the elements identified in paragraphs (g)(2)(i) through (vi) of this section.

(i) General identification information for the facility including a mailing address, the physical address, the owner or operator or responsible official (where applicable) and his/her email address, and the appropriate Federal Registry System (FRS) number for the facility.

(ii) Purpose of the test including the applicable regulation requiring the test, the pollutant(s) and other parameters being measured, the applicable emission standard, and any process parameter component, and a brief process description.

(iii) Description of the emission unit tested including fuel burned, control devices, and vent characteristics; the appropriate source classification code (SCC); the permitted maximum process rate (where applicable); and the sampling location.

(iv) Description of sampling and analysis procedures used and any modifications to standard procedures, quality assurance procedures and results, record of process operating conditions that demonstrate the applicable test conditions are met, and values for any operating parameters for which limits were being set during the test.

(v) Where a test method, CEMS, PEMS, or COMS performance specification, or on-going quality assurance requirement for a CEMS, PEMS, or COMS requires you record or report, the following shall be included in your report: Record of preparation of standards, record of calibrations, raw data sheets for field sampling, raw data sheets for field and laboratory analyses, chain-of-custody documentation, and example calculations for reported results.

(vi) Identification of the company conducting the performance test including the primary office address, telephone number, and the contact for this test including his/her email address.

**SECTION E. Source Group Restrictions.**

(3) For a minimum of 5 years after a performance test is conducted, the owner or operator shall retain and make available, upon request, for inspection by the Administrator the records or results of such performance test and other data needed to determine emissions from an affected source.

(h) Waiver of performance tests. (1) Until a waiver of a performance testing requirement has been granted by the Administrator under this paragraph, the owner or operator of an affected source remains subject to the requirements of this section.

(2) Individual performance tests may be waived upon written application to the Administrator if, in the Administrator's judgment, the source is meeting the relevant standard(s) on a continuous basis, or the source is being operated under an extension of compliance, or the owner or operator has requested an extension of compliance and the Administrator is still considering that request.

(3) Request to waive a performance test. (i) If a request is made for an extension of compliance under §63.6(i), the application for a waiver of an initial performance test shall accompany the information required for the request for an extension of compliance. If no extension of compliance is requested or if the owner or operator has requested an extension of compliance and the Administrator is still considering that request, the application for a waiver of an initial performance test shall be submitted at least 60 days before the performance test if the site-specific test plan under paragraph (c) of this section is not submitted.

(ii) If an application for a waiver of a subsequent performance test is made, the application may accompany any required compliance progress report, compliance status report, or excess emissions and continuous monitoring system performance report [such as those required under §63.6(i), §63.9(h), and §63.10(e) or specified in a relevant standard or in the source's title V permit], but it shall be submitted at least 60 days before the performance test if the site-specific test plan required under paragraph (c) of this section is not submitted.

(iii) Any application for a waiver of a performance test shall include information justifying the owner or operator's request for a waiver, such as the technical or economic infeasibility, or the impracticality, of the affected source performing the required test.

(4) Approval of request to waive performance test. The Administrator will approve or deny a request for a waiver of a performance test made under paragraph (h)(3) of this section when he/she—

(i) Approves or denies an extension of compliance under §63.6(i)(8); or

(ii) Approves or disapproves a site-specific test plan under §63.7(c)(3); or

(iii) Makes a determination of compliance following the submission of a required compliance status report or excess emissions and continuous monitoring systems performance report; or

(iv) Makes a determination of suitable progress towards compliance following the submission of a compliance progress report, whichever is applicable.

(5) Approval of any waiver granted under this section shall not abrogate the Administrator's authority under the Act or in any way prohibit the Administrator from later canceling the waiver. The cancellation will be made only after notice is given to the owner or operator of the affected source.

004 [40 CFR Part 63 NESHAPS for Source Categories §40 CFR Subpart 63.10006]

SUBPART UUUU - National Emission Standards for Hazardous Air Pollutants: Coal- and Oil-Fired Electric Utility Steam Generating Units

When must I conduct subsequent performance tests or tune-ups?

(a) Not applicable.

(b) For affected units meeting the LEE requirements of §63.10005(h), you must repeat the performance test once every 3 years (once every year for Hg) according to Table 5 and §63.10007. Should subsequent emissions testing results show the unit does not meet the LEE eligibility requirements, LEE status is lost. If this should occur:

**SECTION E. Source Group Restrictions.**

- (1) For all pollutant emission limits except for Hg, you must conduct emissions testing quarterly, except as otherwise provided in §63.10021(d)(1).
- (2) For Hg, you must install, certify, maintain, and operate a Hg CEMS or a sorbent trap monitoring system in accordance with appendix A to this subpart, within 6 calendar months of losing LEE eligibility. Until the Hg CEMS or sorbent trap monitoring system is installed, certified, and operating, you must conduct Hg emissions testing quarterly, except as otherwise provided in §63.10021(d)(1). You must have 3 calendar years of testing and CEMS or sorbent trap monitoring system data that satisfy the LEE emissions criteria to reestablish LEE status.
- (c) Not applicable.
- (d) Except where paragraph (b) of this section applies, for solid oil-derived fuel- and coal-fired EGUs that do not use either an HCl CEMS to monitor compliance with the HCl limit or an SO₂ CEMS to monitor compliance with the alternate equivalent SO₂ emission limit, you must conduct all applicable periodic HCl emissions tests according to Table 5 to this subpart and §63.10007 at least quarterly, except as otherwise provided in §63.10021(d)(1).
- (e) Not applicable.
- (f) Time between performance tests. (1) Notwithstanding the provisions of §63.10021(d)(1), the requirements listed in paragraphs (g) and (h) of this section, and the requirements of paragraph (f)(3) of this section, you must complete performance tests for your EGU as follows:
- (i) At least 45 calendar days, measured from the test's end date, must separate performance tests conducted every quarter;
- (ii) For annual testing:
- (A) At least 320 calendar days, measured from the test's end date, must separate performance tests;
- (B) At least 320 calendar days, measured from the test's end date, must separate annual sorbent trap mercury testing for 30-boiler operating day LEE tests;
- (C) At least 230 calendar days, measured from the test's end date, must separate annual sorbent trap mercury testing for 90-boiler operating day LEE tests; and
- (iii) At least 1,050 calendar days, measured from the test's end date, must separate performance tests conducted every 3 years.
- (2) For units demonstrating compliance through quarterly emission testing, you must conduct a performance test in the 4th quarter of a calendar year if your EGU has skipped performance tests in the first 3 quarters of the calendar year.
- (3) If your EGU misses a performance test deadline due to being inoperative and if 168 or more boiler operating hours occur in the next test period, you must complete an additional performance test in that period as follows:
- (i) At least 15 calendar days must separate two performance tests conducted in the same quarter.
- (ii) At least 107 calendar days must separate two performance tests conducted in the same calendar year.
- (iii) At least 350 calendar days must separate two performance tests conducted in the same 3 year period.
- (g) If you elect to demonstrate compliance using emissions averaging under §63.10009, you must continue to conduct performance stack tests at the appropriate frequency given in section (c) through (f) of this section. [Keystone is currently not electing this compliance strategy]
- (h) If a performance test on a non-mercury LEE shows emissions in excess of 50 percent of the emission limit and if you choose to reapply for LEE status, you must conduct performance tests at the appropriate frequency given in section (c) through (e) of this section for that pollutant until all performance tests over a consecutive 3-year period show compliance with the LEE criteria.

**SECTION E. Source Group Restrictions.**

(i) If you are required to meet an applicable tune-up work practice standard, you must conduct a performance tune-up according to §63.10021(e).

(1) For EGUs not employing neural network combustion optimization during normal operation, each performance tune-up specified in §63.10021(e) must be no more than 36 calendar months after the previous performance tune-up.

(2) Not applicable.

005 [40 CFR Part 63 NESHAPS for Source Categories §40 CFR Subpart 63.10007]

SUBPART UUUUU - National Emission Standards for Hazardous Air Pollutants: Coal- and Oil-Fired Electric Utility Steam Generating Units

What methods and other procedures must I use for the performance tests?

(a) Except as otherwise provided in this section, you must conduct all required performance tests according to §63.7(d), (e), (f), and (h). You must also develop a site-specific test plan according to the requirements in §63.7(c).

(1) Not applicable.

(2) If you conduct performance testing with test methods in lieu of continuous monitoring, operate the unit at maximum normal operating load conditions during each periodic (e.g., quarterly) performance test. Maximum normal operating load will be generally between 90 and 110 percent of design capacity but should be representative of site specific normal operations during each test run.

(3) Not applicable.

(b) You must conduct each performance test (including traditional 3-run stack tests, 30-boiler operating day tests based on CEMS data (or sorbent trap monitoring system data), and 30-boiler operating day Hg emission tests for LEE qualification) according to the requirements in Table 5 to this subpart.

(c) Not applicable.

(d) Except for a 30-boiler operating day performance test based on CEMS (or sorbent trap monitoring system) data, where the concept of test runs does not apply, you must conduct a minimum of three separate test runs for each performance test, as specified in §63.7(e)(3). Each test run must comply with the minimum applicable sampling time or volume specified in Table 1 or 2 to this subpart. Sections 63.10005(d) and (h), respectively, provide special instructions for conducting performance tests based on CEMS or sorbent trap monitoring systems, and for conducting emission tests for LEE qualification.

(e) To use the results of performance testing to determine compliance with the applicable emission limits in Table 1 or 2 to this subpart, proceed as follows:

(1) Except for a 30-boiler operating day performance test based on CEMS (or sorbent trap monitoring system) data, if measurement results for any pollutant are reported as below the method detection level (e.g., laboratory analytical results for one or more sample components are below the method defined analytical detection level), you must use the method detection level as the measured emissions level for that pollutant in calculating compliance. The measured result for a multiple component analysis (e.g., analytical values for multiple Method 29 fractions both for individual HAP metals and for total HAP metals) may include a combination of method detection level data and analytical data reported above the method detection level.

(2) If the limits are expressed in lb/MMBtu or lb/TBtu, you must use the F-factor methodology and equations in sections 12.2 and 12.3 of EPA Method 19 in appendix A-7 to part 60 of this chapter. In cases where an appropriate F-factor is not listed in Table 19-2 of Method 19, you may use F-factors from Table 1 in section 3.3.5 of appendix F to part 75 of this chapter, or F-factors derived using the procedures in section 3.3.6 of appendix to part 75 of this chapter. Use the following factors to convert the pollutant concentrations measured during the initial performance tests to units of lb/scf, for use in the applicable Method 19 equations:

(i) Multiply SO₂ ppm by 1.66×10^{-7} ;

**SECTION E. Source Group Restrictions.**

(ii) Multiply HCl ppm by 9.43×10^{-8} ;

(iii) Multiply HF ppm by 5.18×10^{-8} ;

(iv) Multiply HAP metals concentrations (mg/dscm) by 6.24×10^{-8} ; and

(v) Multiply Hg concentrations ($\mu\text{g}/\text{scm}$) by 6.24×10^{-11} .

(3) To determine compliance with emission limits expressed in lb/MWh or lb/GWh, you must first calculate the pollutant mass emission rate during the performance test, in units of lb/h. For Hg, if a CEMS or sorbent trap monitoring system is used, use Equation A-2 or A-3 in appendix A to this subpart (as applicable). In all other cases, use an equation that has the general form of Equation A-2 or A-3, replacing the value of K with 1.66×10^{-7} lb/scf-ppm for SO₂, 9.43×10^{-8} lb/scf-ppm for HCl (if an HCl CEMS is used), 5.18×10^{-8} lb/scf-ppm for HF (if an HF CEMS is used), or 6.24×10^{-8} lb-scm/mg-scf for HAP metals and for HCl and HF (when performance stack testing is used), and defining Ch as the average SO₂, HCl, or HF concentration in ppm, or the average HAP metals concentration in mg/dscm. This calculation requires stack gas volumetric flow rate (scfh) and (in some cases) moisture content data (see §§63.10005(h)(3) and 63.10010). Then, if the applicable emission limit is in units of lb/GWh, use Equation A-4 in appendix A to this subpart to calculate the pollutant emission rate in lb/GWh. In this calculation, define (M)h as the calculated pollutant mass emission rate for the performance test (lb/h), and define (MW)h as the average electrical load during the performance test (megawatts). If the applicable emission limit is in lb/MWh rather than lb/GWh, omit the 103 term from Equation A-4 to determine the pollutant emission rate in lb/MWh.

(f) If you elect to (or are required to) use CEMS to continuously monitor Hg, HCl, HF, SO₂, or PM emissions (or, if applicable, sorbent trap monitoring systems to continuously collect Hg emissions data), the following default values are available for use in the emission rate calculations during startup periods or shutdown periods (as defined in §63.10042). For the purposes of this subpart, these default values are not considered to be substitute data.

(1) Diluent cap values. If you use CEMS (or, if applicable, sorbent trap monitoring systems) to comply with a heat input-based emission rate limit, you may use the following diluent cap values for a startup or shutdown hour in which the measured CO₂ concentration is below the cap value or the measured O₂ concentration is above the cap value:

(i) For an IGCC EGU, you may use 1% for CO₂ or 19% for O₂.

(ii) For all other EGUs, you may use 5% for CO₂ or 14% for O₂.

(2) Default gross output. If you use CEMS to continuously monitor Hg, HCl, HF, SO₂, or PM emissions (or, if applicable, sorbent trap monitoring systems to continuously collect Hg emissions data), the following default value is available for use in the emission rate calculations during startup periods or shutdown periods (as defined in §63.10042). For the purposes of this subpart, this default value is not considered to be substitute data. For a startup or shutdown hour in which there is heat input to an affected EGU but zero gross output, you must calculate the pollutant emission rate using a value equivalent to 5% of the maximum sustainable gross output, expressed in megawatts, as defined in section 6.5.2.1(a)(1) of appendix A to part 75 of this chapter. This default gross output is either the nameplate capacity of the EGU or the highest gross output observed in at least four representative quarters of EGU operation. For a monitored common stack, the default gross output is used only when all EGUs are operating (i.e., combusting fuel) are in startup or shutdown mode, and have zero electrical generation. Under those conditions, a default gross output equal to 5% of the combined maximum sustainable gross output of the EGUs that are operating but have a total of zero gross output must be used to calculate the hourly gross output-based pollutant emissions rate.

(g) Upon request, you shall make available to the EPA Administrator such records as may be necessary to determine whether the performance tests have been done according to the requirements of this section.

006 [40 CFR Part 63 NESHAPS for Source Categories §Table 5 to Subpart UUUUU of Part 63]

SUBPART UUUUU - National Emission Standards for Hazardous Air Pollutants: Coal- and Oil-Fired Electric Utility Steam Generating Units

Performance Testing Requirements

As stated in §63.10007, you must comply with the following requirements for performance testing for existing, new or reconstructed affected sources:[1 and 2]

**SECTION E. Source Group Restrictions.**

(1) To conduct a performance test for Filterable Particulate matter (PM) using emissions testing you must perform the following activities, as applicable to your input- or output based emission limit:

(a) Select sampling ports location and the number of traverse points using Method 1 at appendix A-1 to part 60 of this chapter.

(b) Determine velocity and volumetric flow-rate of the stack gas using Method 2, 2A, 2C, 2F, 2G or 2H at appendix A-1 or A-2 to part 60 of this chapter.

(c) Determine oxygen and carbon dioxide concentrations of the stack gas using Method 3A or 3B at appendix A-2 to part 60 of this chapter, or ANSI/ASME PTC 19.10-1981.[3]

(d) Measure the moisture content of the stack gas using Method 4 at appendix A-3 to part 60 of this chapter.

(e) Measure the filterable PM concentration using Methods 5 and 5I at appendix A-3 to part 60 of this chapter. For positive pressure fabric filters, Method 5D at appendix A-3 to part 60 of this chapter for filterable PM emissions. Note that the Method 5 or 5I front half temperature shall be $160^{\circ} \pm 14^{\circ} \text{C}$ ($320^{\circ} \pm 25^{\circ} \text{F}$).

(f) Convert emissions concentration to lb/MMBtu or lb/MWh emissions rates using Method 19 F-factor methodology at appendix A-7 to part 60 of this chapter, or calculate using mass emissions rate and gross output data (see §63.10007(e)).

(2) Total or individual non-Hg HAP metals- Not applicable.

(3) To conduct performance test for Hydrogen chloride (HCl) and hydrogen fluoride (HF) using emissions testing you must perform the following activities, as applicable to your input- or output based emission limit:

(a) Select sampling ports location and the number of traverse points using Method 1 at appendix A-1 to part 60 of this chapter.

(b) Determine velocity and volumetric flow-rate of the stack gas using Method 2, 2A, 2C, 2F, 2G or 2H at appendix A-1 or A-2 to part 60 of this chapter.

(c) Determine oxygen and carbon dioxide concentrations of the stack gas using Method 3A or 3B at appendix A-2 to part 60 of this chapter, or ANSI/ASME PTC 19.10-1981.3

(d) Measure the moisture content of the stack gas using Method 4 at appendix A-3 to part 60 of this chapter.

(e) Measure the HCl and HF emissions concentrations using Method 26 or Method 26A at appendix A-8 to part 60 of this chapter or Method 320 at appendix A to part 63 of this chapter or ASTM D6348-03[3] with:

(1) the following conditions when using ASTM D6348-03:

(A) The test plan preparation and implementation in the Annexes to ASTM D6348-03, Sections A1 through A8 are mandatory;

(B) For ASTM D6348-03 Annex A5 (Analyte Spiking Technique), the percent (%) R must be determined for each target analyte (see Equation A5.5);

(C) For the ASTM D6348-03 test data to be acceptable for a target analyte, %R must be $70\% \leq R \leq 130\%$; and

(D) The %R value for each compound must be reported in the test report and all field measurements corrected with the calculated %R value for that compound using the following equation: [Please refer to Table 5 under Part 63, Subpart UUUUU Title 40 - Protection of Environment in www.ecfr.gov for equation]

(2) spiking levels nominally no greater than two times the level corresponding to the applicable emission limit. Method 26A must be used if there are entrained water droplets in the exhaust stream.

(f) Convert emissions concentration to lb/MMBtu or lb/MWh emissions rates using Method 19 F-factor methodology at appendix A-7 to part 60 of this chapter, or calculate using mass emissions rate and gross output data (see §63.10007(e)).

(4) To conduct a performance test for Mercury (Hg) using sorbent trap monitoring system you must perform the following activities, as applicable to your input- or output based emission limit:

(a) Install, certify, operate, and maintain the sorbent trap monitoring system using Sections 3.2.2 and 5.2 of appendix A to this subpart.

(b) Install, operate, and maintain the diluent gas, flow rate, and/or moisture monitoring systems using Part 75 of this chapter and §63.10010(a), (b), (c), and (d).

(c) Convert emissions concentrations to 30 boiler operating day rolling average lb/TBtu or lb/GWh emissions rates using

**SECTION E. Source Group Restrictions.**

Section 6 of appendix A to this subpart.

(5) Not applicable.

[1] Regarding emissions data collected during periods of startup or shutdown, see §§63.10020(b) and (c) and 63.10021(h).

[2] See Tables 1 and 2 to this subpart for required sample volumes and/or sampling run times.

[3] Incorporated by reference, see §63.14.

III. MONITORING REQUIREMENTS.**# 007 [40 CFR Part 63 NESHAPS for Source Categories §40 CFR 63.8]****Subpart A--General Provisions****Monitoring requirements.**

40 CFR §63.8(f)(4) Use of an alternative monitoring method

(4)(i) Request to use alternative monitoring procedure. An owner or operator who wishes to use an alternative monitoring procedure must submit an application to the Administrator as described in paragraph (f)(4)(ii) of this section. The application may be submitted at any time provided that the monitoring procedure is not the performance test method used to demonstrate compliance with a relevant standard or other requirement. If the alternative monitoring procedure will serve as the performance test method that is to be used to demonstrate compliance with a relevant standard, the application must be submitted at least 60 days before the performance evaluation is scheduled to begin and must meet the requirements for an alternative test method under §63.7(f).

(ii) The application must contain a description of the proposed alternative monitoring system which addresses the four elements contained in the definition of monitoring in §63.2 and a performance evaluation test plan, if required, as specified in paragraph (e)(3) of this section. In addition, the application must include information justifying the owner or operator's request for an alternative monitoring method, such as the technical or economic infeasibility, or the impracticality, of the affected source using the required method.

(iii) The owner or operator may submit the information required in this paragraph well in advance of the submittal dates specified in paragraph (f)(4)(i) above to ensure a timely review by the Administrator in order to meet the compliance demonstration date specified in this section or the relevant standard.

(iv) Application for minor changes to monitoring procedures, as specified in paragraph (b)(1) of this section, may be made in the site-specific performance evaluation plan.

008 [40 CFR Part 63 NESHAPS for Source Categories §40 CFR 63.8]**Subpart A--General Provisions****Monitoring requirements.**

40 CFR §63.8(d)(3) Quality control program.

(3) The owner or operator shall keep these written procedures on record for the life of the affected source or until the affected source is no longer subject to the provisions of this part, to be made available for inspection, upon request, by the Administrator. If the performance evaluation plan is revised, the owner or operator shall keep previous (i.e., superseded) versions of the performance evaluation plan on record to be made available for inspection, upon request, by the Administrator, for a period of 5 years after each revision to the plan. Where relevant, e.g., program of corrective action for a malfunctioning CMS, these written procedures may be incorporated as part of the affected source's startup, shutdown, and malfunction plan to avoid duplication of planning and recordkeeping efforts.

009 [40 CFR Part 63 NESHAPS for Source Categories §40 CFR 63.8]**Subpart A--General Provisions****Monitoring requirements.**

40 CFR §63.8(e)

(e) Performance evaluation of continuous monitoring systems—(1) General. When required by a relevant standard, and at any other time the Administrator may require under section 114 of the Act, the owner or operator of an affected source being monitored shall conduct a performance evaluation of the CMS. Such performance evaluation shall be conducted according to the applicable specifications and procedures described in this section or in the relevant standard.

**SECTION E. Source Group Restrictions.**

(2) Notification of performance evaluation. The owner or operator shall notify the Administrator in writing of the date of the performance evaluation simultaneously with the notification of the performance test date required under §63.7(b) or at least 60 days prior to the date the performance evaluation is scheduled to begin if no performance test is required.

(3)(i) Submission of site-specific performance evaluation test plan. Before conducting a required CMS performance evaluation, the owner or operator of an affected source shall develop and submit a site-specific performance evaluation test plan to the Administrator for approval upon request. The performance evaluation test plan shall include the evaluation program objectives, an evaluation program summary, the performance evaluation schedule, data quality objectives, and both an internal and external QA program. Data quality objectives are the pre-evaluation expectations of precision, accuracy, and completeness of data.

(ii) The internal QA program shall include, at a minimum, the activities planned by routine operators and analysts to provide an assessment of CMS performance. The external QA program shall include, at a minimum, systems audits that include the opportunity for on-site evaluation by the Administrator of instrument calibration, data validation, sample logging, and documentation of quality control data and field maintenance activities.

(iii) The owner or operator of an affected source shall submit the site-specific performance evaluation test plan to the Administrator (if requested) at least 60 days before the performance test or performance evaluation is scheduled to begin, or on a mutually agreed upon date, and review and approval of the performance evaluation test plan by the Administrator will occur with the review and approval of the site-specific test plan (if review of the site-specific test plan is requested).

(iv) The Administrator may request additional relevant information after the submittal of a site-specific performance evaluation test plan.

(v) In the event that the Administrator fails to approve or disapprove the site-specific performance evaluation test plan within the time period specified in §63.7(c)(3), the following conditions shall apply:

(A) If the owner or operator intends to demonstrate compliance using the monitoring method(s) specified in the relevant standard, the owner or operator shall conduct the performance evaluation within the time specified in this subpart using the specified method(s);

(B) If the owner or operator intends to demonstrate compliance by using an alternative to a monitoring method specified in the relevant standard, the owner or operator shall refrain from conducting the performance evaluation until the Administrator approves the use of the alternative method. If the Administrator does not approve the use of the alternative method within 30 days before the performance evaluation is scheduled to begin, the performance evaluation deadlines specified in paragraph (e)(4) of this section may be extended such that the owner or operator shall conduct the performance evaluation within 60 calendar days after the Administrator approves the use of the alternative method. Notwithstanding the requirements in the preceding two sentences, the owner or operator may proceed to conduct the performance evaluation as required in this section (without the Administrator's prior approval of the site-specific performance evaluation test plan) if he/she subsequently chooses to use the specified monitoring method(s) instead of an alternative.

(vi) Neither the submission of a site-specific performance evaluation test plan for approval, nor the Administrator's approval or disapproval of a plan, nor the Administrator's failure to approve or disapprove a plan in a timely manner shall—

(A) Relieve an owner or operator of legal responsibility for compliance with any applicable provisions of this part or with any other applicable Federal, State, or local requirement; or

(B) Prevent the Administrator from implementing or enforcing this part or taking any other action under the Act.

(4) Conduct of performance evaluation and performance evaluation dates. The owner or operator of an affected source shall conduct a performance evaluation of a required CMS during any performance test required under §63.7 in accordance with the applicable performance specification as specified in the relevant standard. Notwithstanding the requirement in the previous sentence, if the owner or operator of an affected source elects to submit COMS data for compliance with a relevant opacity emission standard as provided under §63.6(h)(7), he/she shall conduct a performance evaluation of the COMS as specified in the relevant standard, before the performance test required under §63.7 is conducted in time to submit the results of the performance evaluation as specified in paragraph (e)(5)(ii) of this section. If a performance test is not required, or the requirement for a performance test has been waived under §63.7(h), the owner or operator of an affected

**SECTION E. Source Group Restrictions.**

source shall conduct the performance evaluation not later than 180 days after the appropriate compliance date for the affected source, as specified in §63.7(a), or as otherwise specified in the relevant standard.

(5) Reporting performance evaluation results. (i) The owner or operator shall furnish the Administrator a copy of a written report of the results of the performance evaluation containing the information specified in §63.7(g)(2)(i) through (vi) simultaneously with the results of the performance test required under §63.7 or within 60 days of completion of the performance evaluation, unless otherwise specified in a relevant standard.

(ii) The owner or operator of an affected source using a COMS to determine opacity compliance during any performance test required under §63.7 and described in §63.6(d)(6) shall furnish the Administrator two or, upon request, three copies of a written report of the results of the COMS performance evaluation under this paragraph. The copies shall be provided at least 15 calendar days before the performance test required under §63.7 is conducted.

010 [40 CFR Part 63 NESHAPS for Source Categories §40 CFR 63.8]

Subpart A--General Provisions

Monitoring requirements.

40 CFR §63.8(f)(6)

(6) Alternative to the relative accuracy test. An alternative to the relative accuracy test for CEMS specified in a relevant standard may be requested as follows:

(i) Criteria for approval of alternative procedures. An alternative to the test method for determining relative accuracy is available for affected sources with emission rates demonstrated to be less than 50 percent of the relevant standard. The owner or operator of an affected source may petition the Administrator under paragraph (f)(6)(ii) of this section to substitute the relative accuracy test in section 7 of Performance Specification 2 with the procedures in section 10 if the results of a performance test conducted according to the requirements in §63.7, or other tests performed following the criteria in §63.7, demonstrate that the emission rate of the pollutant of interest in the units of the relevant standard is less than 50 percent of the relevant standard. For affected sources subject to emission limitations expressed as control efficiency levels, the owner or operator may petition the Administrator to substitute the relative accuracy test with the procedures in section 10 of Performance Specification 2 if the control device exhaust emission rate is less than 50 percent of the level needed to meet the control efficiency requirement. The alternative procedures do not apply if the CEMS is used continuously to determine compliance with the relevant standard.

(ii) Petition to use alternative to relative accuracy test. The petition to use an alternative to the relative accuracy test shall include a detailed description of the procedures to be applied, the location and the procedure for conducting the alternative, the concentration or response levels of the alternative relative accuracy materials, and the other equipment checks included in the alternative procedure(s). The Administrator will review the petition for completeness and applicability. The Administrator's determination to approve an alternative will depend on the intended use of the CEMS data and may require specifications more stringent than in Performance Specification 2.

(iii) Rescission of approval to use alternative to relative accuracy test. The Administrator will review the permission to use an alternative to the CEMS relative accuracy test and may rescind such permission if the CEMS data from a successful completion of the alternative relative accuracy procedure indicate that the affected source's emissions are approaching the level of the relevant standard. The criterion for reviewing the permission is that the collection of CEMS data shows that emissions have exceeded 70 percent of the relevant standard for any averaging period, as specified in the relevant standard. For affected sources subject to emission limitations expressed as control efficiency levels, the criterion for reviewing the permission is that the collection of CEMS data shows that exhaust emissions have exceeded 70 percent of the level needed to meet the control efficiency requirement for any averaging period, as specified in the relevant standard. The owner or operator of the affected source shall maintain records and determine the level of emissions relative to the criterion for permission to use an alternative for relative accuracy testing. If this criterion is exceeded, the owner or operator shall notify the Administrator within 10 days of such occurrence and include a description of the nature and cause of the increased emissions. The Administrator will review the notification and may rescind permission to use an alternative and require the owner or operator to conduct a relative accuracy test of the CEMS as specified in section 7 of Performance Specification 2. The Administrator will review the notification and may rescind permission to use an alternative and require the owner or operator to conduct a relative accuracy test of the CEMS as specified in section 8.4 of Performance Specification 2.

SECTION E. Source Group Restrictions.**# 011 [40 CFR Part 63 NESHAPS for Source Categories §40 CFR 63.8]****Subpart A--General Provisions****Monitoring requirements.**

40 CFR §63.8(c)(7)

(7)(i) A CMS is out of control if—

(A) The zero (low-level), mid-level (if applicable), or high-level calibration drift (CD) exceeds two times the applicable CD specification in the applicable performance specification or in the relevant standard; or

(B) The CMS fails a performance test audit (e.g., cylinder gas audit), relative accuracy audit, relative accuracy test audit, or linearity test audit; or

(C) The COMS CD exceeds two times the limit in the applicable performance specification in the relevant standard.

(ii) When the CMS is out of control, the owner or operator of the affected source shall take the necessary corrective action and shall repeat all necessary tests which indicate that the system is out of control. The owner or operator shall take corrective action and conduct retesting until the performance requirements are below the applicable limits. The beginning of the out-of-control period is the hour the owner or operator conducts a performance check (e.g., calibration drift) that indicates an exceedance of the performance requirements established under this part. The end of the out-of-control period is the hour following the completion of corrective action and successful demonstration that the system is within the allowable limits. During the period the CMS is out of control, recorded data shall not be used in data averages and calculations, or to meet any data availability requirement established under this part.

012 [40 CFR Part 63 NESHAPS for Source Categories §40 CFR Subpart 63.10010]**SUBPART UUUUU - National Emission Standards for Hazardous Air Pollutants: Coal- and Oil-Fired Electric Utility Steam Generating Units****What are my monitoring, installation, operation, and maintenance requirements?**

(a) Flue gases from the affected units under this subpart exhaust to the atmosphere through a variety of different configurations, including but not limited to individual stacks, a common stack configuration or a main stack plus a bypass stack. For the CEMS, PM CPMS, and sorbent trap monitoring systems used to provide data under this subpart, the continuous monitoring system installation requirements for these exhaust configurations are as follows:

(1) Single unit-single stack configurations. For an affected unit that exhausts to the atmosphere through a single, dedicated stack, you shall either install the required CEMS, PM CPMS, and sorbent trap monitoring systems in the stack or at a location in the ductwork downstream of all emissions control devices, where the pollutant and diluents concentrations are representative of the emissions that exit to the atmosphere.

(2) Unit utilizing common stack with other affected unit(s). Not applicable.

(3) Unit(s) utilizing common stack with non-affected unit(s). Not applicable.

(4) Unit with a main stack and a bypass stack that exhausts to the atmosphere independent of the main stack. Not applicable.

(5) Unit with a common control device with multiple stack or duct configuration. Not applicable.

(6) Unit with multiple parallel control devices with multiple stacks. Not applicable.

(b) If you use an oxygen (O₂) or carbon dioxide (CO₂) CEMS to convert measured pollutant concentrations to the units of the applicable emissions limit, the O₂ or CO₂ concentrations shall be monitored at a location that represents emissions to the atmosphere, i.e., at the outlet of the EGU, downstream of all emission control devices. You must install, certify, maintain, and operate the CEMS according to part 75 of this chapter. Use only quality-assured O₂ or CO₂ data in the emissions calculations; do not use part 75 substitute data values.

(c) If you are required to use a stack gas flow rate monitor, either for routine operation of a sorbent trap monitoring system or to convert pollutant concentrations to units of an electrical output-based emission standard in Table 1 or 2 to this subpart,

**SECTION E. Source Group Restrictions.**

you must install, certify, operate, and maintain the monitoring system and conduct on-going quality-assurance testing of the system according to part 75 of this chapter. Use only unadjusted, quality-assured flow rate data in the emissions calculations. Do not apply bias adjustment factors to the flow rate data and do not use substitute flow rate data in the calculations.

(d)-(f) Not applicable.

(g) If you use a Hg CEMS or a sorbent trap monitoring system, you must install, certify, operate, maintain and quality-assure the data from the monitoring system in accordance with appendix A to this subpart. You must calculate and record a 30- (or, if alternate emissions averaging is used, 90-) boiler operating day rolling average Hg emission rate, in units of the standard, updated after each new boiler operating day. Each 30- (or, if alternate emissions averaging is used, 90-) boiler operating day rolling average emission rate, calculated according to section 6.2 of appendix A to the subpart, is the average of all of the valid hourly Hg emission rates in the preceding 30- (or, if alternate emissions averaging is used, a 90-) boiler operating days. Section 7.1.4.3 of appendix A to this subpart explains how to reduce sorbent trap monitoring system data to an hourly basis.

(h)-(l) Not applicable.

013 [40 CFR Part 63 NESHAPS for Source Categories §40 CFR Subpart 63.10020]

SUBPART UUUUU - National Emission Standards for Hazardous Air Pollutants: Coal- and Oil-Fired Electric Utility Steam Generating Units

How do I monitor and collect data to demonstrate continuous compliance?

(a) You must monitor and collect data according to this section and the site-specific monitoring plan required by §63.10000(d).

(b) You must operate the monitoring system and collect data at all required intervals at all times that the affected EGU is operating, except for periods of monitoring system malfunctions or out-of-control periods (see §63.8(c)(7) of this part), and required monitoring system quality assurance or quality control activities, including, as applicable, calibration checks and required zero and span adjustments. You are required to affect monitoring system repairs in response to monitoring system malfunctions and to return the monitoring system to operation as expeditiously as practicable.

(c) You may not use data recorded during EGU startup or shutdown in calculations used to report emissions, except as otherwise provided in §§63.10000(c)(1)(vi)(B) and 63.10005(a)(2)(iii). In addition, data recorded during monitoring system malfunctions or monitoring system out-of-control periods, repairs associated with monitoring system malfunctions or monitoring system out-of-control periods, or required monitoring system quality assurance or control activities may not be used in calculations used to report emissions or operating levels. You must use all of the quality-assured data collected during all other periods in assessing the operation of the control device and associated control system.

(d) Except for periods of monitoring system malfunctions or monitoring system out-of-control periods, repairs associated with monitoring system malfunctions or monitoring system out-of-control periods, and required monitoring system quality assurance or quality control activities including, as applicable, calibration checks and required zero and span adjustments), failure to collect required data is a deviation from the monitoring requirements.

(e) Not applicable.

IV. RECORDKEEPING REQUIREMENTS.

014 [40 CFR Part 63 NESHAPS for Source Categories §40 CFR 63.10]

Subpart A--General Provisions

Recordkeeping and reporting requirements.

a) Applicability and general information. (1) The applicability of this section is set out in §63.1(a)(4).

(2) For affected sources that have been granted an extension of compliance under subpart D of this part, the requirements of this section do not apply to those sources while they are operating under such compliance extensions.

(3) If any State requires a report that contains all the information required in a report listed in this section, an owner or operator may send the Administrator a copy of the report sent to the State to satisfy the requirements of this section for that report.

**SECTION E. Source Group Restrictions.**

(4)(i) Before a State has been delegated the authority to implement and enforce recordkeeping and reporting requirements established under this part, the owner or operator of an affected source in such State subject to such requirements shall submit reports to the appropriate Regional Office of the EPA (to the attention of the Director of the Division indicated in the list of the EPA Regional Offices in §63.13).

(ii) After a State has been delegated the authority to implement and enforce recordkeeping and reporting requirements established under this part, the owner or operator of an affected source in such State subject to such requirements shall submit reports to the delegated State authority (which may be the same as the permitting authority). In addition, if the delegated (permitting) authority is the State, the owner or operator shall send a copy of each report submitted to the State to the appropriate Regional Office of the EPA, as specified in paragraph (a)(4)(i) of this section. The Regional Office may waive this requirement for any reports at its discretion.

(5) If an owner or operator of an affected source in a State with delegated authority is required to submit periodic reports under this part to the State, and if the State has an established timeline for the submission of periodic reports that is consistent with the reporting frequency(ies) specified for such source under this part, the owner or operator may change the dates by which periodic reports under this part shall be submitted (without changing the frequency of reporting) to be consistent with the State's schedule by mutual agreement between the owner or operator and the State. For each relevant standard established pursuant to section 112 of the Act, the allowance in the previous sentence applies in each State beginning 1 year after the affected source's compliance date for that standard. Procedures governing the implementation of this provision are specified in §63.9(i).

(6) If an owner or operator supervises one or more stationary sources affected by more than one standard established pursuant to section 112 of the Act, he/she may arrange by mutual agreement between the owner or operator and the Administrator (or the State permitting authority) a common schedule on which periodic reports required for each source shall be submitted throughout the year. The allowance in the previous sentence applies in each State beginning 1 year after the latest compliance date for any relevant standard established pursuant to section 112 of the Act for any such affected source(s). Procedures governing the implementation of this provision are specified in §63.9(i).

(7) If an owner or operator supervises one or more stationary sources affected by standards established pursuant to section 112 of the Act (as amended November 15, 1990) and standards set under part 60, part 61, or both such parts of this chapter, he/she may arrange by mutual agreement between the owner or operator and the Administrator (or the State permitting authority) a common schedule on which periodic reports required by each relevant (i.e., applicable) standard shall be submitted throughout the year. The allowance in the previous sentence applies in each State beginning 1 year after the stationary source is required to be in compliance with the relevant section 112 standard, or 1 year after the stationary source is required to be in compliance with the applicable part 60 or part 61 standard, whichever is latest. Procedures governing the implementation of this provision are specified in §63.9(i).

(b) General recordkeeping requirements. (1) The owner or operator of an affected source subject to the provisions of this part shall maintain files of all information (including all reports and notifications) required by this part recorded in a form suitable and readily available for expeditious inspection and review. The files shall be retained for at least 5 years following the date of each occurrence, measurement, maintenance, corrective action, report, or record. At a minimum, the most recent 2 years of data shall be retained on site. The remaining 3 years of data may be retained off site. Such files may be maintained on microfilm, on a computer, on computer floppy disks, on magnetic tape disks, or on microfiche.

(2) The owner or operator of an affected source subject to the provisions of this part shall maintain relevant records for such source of—

(i) The occurrence and duration of each startup or shutdown when the startup or shutdown causes the source to exceed any applicable emission limitation in the relevant emission standards;

(ii) The occurrence and duration of each malfunction of operation (i.e., process equipment) or the required air pollution control and monitoring equipment;

(iii) All required maintenance performed on the air pollution control and monitoring equipment;

(iv)(A) Actions taken during periods of startup or shutdown when the source exceeded applicable emission limitations in a relevant standard and when the actions taken are different from the procedures specified in the affected source's startup,

**SECTION E. Source Group Restrictions.**

shutdown, and malfunction plan (see §63.6(e)(3)); or

(B) Actions taken during periods of malfunction (including corrective actions to restore malfunctioning process and air pollution control and monitoring equipment to its normal or usual manner of operation) when the actions taken are different from the procedures specified in the affected source's startup, shutdown, and malfunction plan (see §63.6(e)(3));

(v) All information necessary, including actions taken, to demonstrate conformance with the affected source's startup, shutdown, and malfunction plan (see §63.6(e)(3)) when all actions taken during periods of startup or shutdown (and the startup or shutdown causes the source to exceed any applicable emission limitation in the relevant emission standards), and malfunction (including corrective actions to restore malfunctioning process and air pollution control and monitoring equipment to its normal or usual manner of operation) are consistent with the procedures specified in such plan. (The information needed to demonstrate conformance with the startup, shutdown, and malfunction plan may be recorded using a "checklist," or some other effective form of recordkeeping, in order to minimize the recordkeeping burden for conforming events);

(vi) Each period during which a CMS is malfunctioning or inoperative (including out-of-control periods);

(vii) All required measurements needed to demonstrate compliance with a relevant standard (including, but not limited to, 15-minute averages of CMS data, raw performance testing measurements, and raw performance evaluation measurements, that support data that the source is required to report);

(A) This paragraph applies to owners or operators required to install a continuous emissions monitoring system (CEMS) where the CEMS installed is automated, and where the calculated data averages do not exclude periods of CEMS breakdown or malfunction. An automated CEMS records and reduces the measured data to the form of the pollutant emission standard through the use of a computerized data acquisition system. In lieu of maintaining a file of all CEMS subhourly measurements as required under paragraph (b)(2)(vii) of this section, the owner or operator shall retain the most recent consecutive three averaging periods of subhourly measurements and a file that contains a hard copy of the data acquisition system algorithm used to reduce the measured data into the reportable form of the standard.

(B) This paragraph applies to owners or operators required to install a CEMS where the measured data is manually reduced to obtain the reportable form of the standard, and where the calculated data averages do not exclude periods of CEMS breakdown or malfunction. In lieu of maintaining a file of all CEMS subhourly measurements as required under paragraph (b)(2)(vii) of this section, the owner or operator shall retain all subhourly measurements for the most recent reporting period. The subhourly measurements shall be retained for 120 days from the date of the most recent summary or excess emission report submitted to the Administrator.

(C) The Administrator or delegated authority, upon notification to the source, may require the owner or operator to maintain all measurements as required by paragraph (b)(2)(vii), if the administrator or the delegated authority determines these records are required to more accurately assess the compliance status of the affected source.

(viii) All results of performance tests, CMS performance evaluations, and opacity and visible emission observations;

(ix) All measurements as may be necessary to determine the conditions of performance tests and performance evaluations;

(x) All CMS calibration checks;

(xi) All adjustments and maintenance performed on CMS;

(xii) Any information demonstrating whether a source is meeting the requirements for a waiver of recordkeeping or reporting requirements under this part, if the source has been granted a waiver under paragraph (f) of this section;

(xiii) All emission levels relative to the criterion for obtaining permission to use an alternative to the relative accuracy test, if the source has been granted such permission under §63.8(f)(6); and

(xiv) All documentation supporting initial notifications and notifications of compliance status under §63.9.

**SECTION E. Source Group Restrictions.**

(3) Recordkeeping requirement for applicability determinations. If an owner or operator determines that his or her stationary source that emits (or has the potential to emit, without considering controls) one or more hazardous air pollutants regulated by any standard established pursuant to section 112(d) or (f), and that stationary source is in the source category regulated by the relevant standard, but that source is not subject to the relevant standard (or other requirement established under this part) because of limitations on the source's potential to emit or an exclusion, the owner or operator must keep a record of the applicability determination on site at the source for a period of 5 years after the determination, or until the source changes its operations to become an affected source, whichever comes first. The record of the applicability determination must be signed by the person making the determination and include an analysis (or other information) that demonstrates why the owner or operator believes the source is unaffected (e.g., because the source is an area source). The analysis (or other information) must be sufficiently detailed to allow the Administrator to make a finding about the source's applicability status with regard to the relevant standard or other requirement. If relevant, the analysis must be performed in accordance with requirements established in relevant subparts of this part for this purpose for particular categories of stationary sources. If relevant, the analysis should be performed in accordance with EPA guidance materials published to assist sources in making applicability determinations under section 112, if any. The requirements to determine applicability of a standard under §63.1(b)(3) and to record the results of that determination under paragraph (b)(3) of this section shall not by themselves create an obligation for the owner or operator to obtain a title V permit.

(c) Additional recordkeeping requirements for sources with continuous monitoring systems. In addition to complying with the requirements specified in paragraphs (b)(1) and (b)(2) of this section, the owner or operator of an affected source required to install a CMS by a relevant standard shall maintain records for such source of—

(1) All required CMS measurements (including monitoring data recorded during unavoidable CMS breakdowns and out-of-control periods);

(2)-(4) [Reserved]

(5) The date and time identifying each period during which the CMS was inoperative except for zero (low-level) and highlevel checks;

(6) The date and time identifying each period during which the CMS was out of control, as defined in §63.8(c)(7);

(7) The specific identification (i.e., the date and time of commencement and completion) of each period of excess emissions and parameter monitoring exceedances, as defined in the relevant standard(s), that occurs during startups, shutdowns, and malfunctions of the affected source;

(8) The specific identification (i.e., the date and time of commencement and completion) of each time period of excess emissions and parameter monitoring exceedances, as defined in the relevant standard(s), that occurs during periods other than startups, shutdowns, and malfunctions of the affected source;

(9) [Reserved]

(10) The nature and cause of any malfunction (if known);

(11) The corrective action taken or preventive measures adopted;

(12) The nature of the repairs or adjustments to the CMS that was inoperative or out of control;

(13) The total process operating time during the reporting period; and

(14) All procedures that are part of a quality control program developed and implemented for CMS under §63.8(d).

(15) In order to satisfy the requirements of paragraphs (c)(10) through (c)(12) of this section and to avoid duplicative recordkeeping efforts, the owner or operator may use the affected source's startup, shutdown, and malfunction plan or records kept to satisfy the recordkeeping requirements of the startup, shutdown, and malfunction plan specified in §63.6(e), provided that such plan and records adequately address the requirements of paragraphs (c)(10) through (c)(12).

(d) General reporting requirements. (1) Notwithstanding the requirements in this paragraph or paragraph (e) of this section, and except as provided in §63.16, the owner or operator of an affected source subject to reporting requirements under this

**SECTION E. Source Group Restrictions.**

part shall submit reports to the Administrator in accordance with the reporting requirements in the relevant standard(s).

(2) Reporting results of performance tests. Before a title V permit has been issued to the owner or operator of an affected source, the owner or operator shall report the results of any performance test under §63.7 to the Administrator. After a title V permit has been issued to the owner or operator of an affected source, the owner or operator shall report the results of a required performance test to the appropriate permitting authority. The owner or operator of an affected source shall report the results of the performance test to the Administrator (or the State with an approved permit program) before the close of business on the 60th day following the completion of the performance test, unless specified otherwise in a relevant standard or as approved otherwise in writing by the Administrator. The results of the performance test shall be submitted as part of the notification of compliance status required under §63.9(h).

(3) Reporting results of opacity or visible emission observations. The owner or operator of an affected source required to conduct opacity or visible emission observations by a relevant standard shall report the opacity or visible emission results (produced using Test Method 9 or Test Method 22, or an alternative to these test methods) along with the results of the performance test required under §63.7. If no performance test is required, or if visibility or other conditions prevent the opacity or visible emission observations from being conducted concurrently with the performance test required under §63.7, the owner or operator shall report the opacity or visible emission results before the close of business on the 30th day following the completion of the opacity or visible emission observations.

(4) Progress reports. The owner or operator of an affected source who is required to submit progress reports as a condition of receiving an extension of compliance under §63.6(i) shall submit such reports to the Administrator (or the State with an approved permit program) by the dates specified in the written extension of compliance.

(5)(i) Periodic startup, shutdown, and malfunction reports. If actions taken by an owner or operator during a startup or shutdown (and the startup or shutdown causes the source to exceed any applicable emission limitation in the relevant emission standards), or malfunction of an affected source (including actions taken to correct a malfunction) are consistent with the procedures specified in the source's startup, shutdown, and malfunction plan (see §63.6(e)(3)), the owner or operator shall state such information in a startup, shutdown, and malfunction report. Actions taken to minimize emissions during such startups, shutdowns, and malfunctions shall be summarized in the report and may be done in checklist form; if actions taken are the same for each event, only one checklist is necessary. Such a report shall also include the number, duration, and a brief description for each type of malfunction which occurred during the reporting period and which caused or may have caused any applicable emission limitation to be exceeded. Reports shall only be required if a startup or shutdown caused the source to exceed any applicable emission limitation in the relevant emission standards, or if a malfunction occurred during the reporting period. The startup, shutdown, and malfunction report shall consist of a letter, containing the name, title, and signature of the owner or operator or other responsible official who is certifying its accuracy, that shall be submitted to the Administrator semiannually (or on a more frequent basis if specified otherwise in a relevant standard or as established otherwise by the permitting authority in the source's title V permit). The startup, shutdown, and malfunction report shall be delivered or postmarked by the 30th day following the end of each calendar half (or other calendar reporting period, as appropriate). If the owner or operator is required to submit excess emissions and continuous monitoring system performance (or other periodic) reports under this part, the startup, shutdown, and malfunction reports required under this paragraph may be submitted simultaneously with the excess emissions and continuous monitoring system performance (or other) reports. If startup, shutdown, and malfunction reports are submitted with excess emissions and continuous monitoring system performance (or other periodic) reports, and the owner or operator receives approval to reduce the frequency of reporting for the latter under paragraph (e) of this section, the frequency of reporting for the startup, shutdown, and malfunction reports also may be reduced if the Administrator does not object to the intended change. The procedures to implement the allowance in the preceding sentence shall be the same as the procedures specified in paragraph (e)(3) of this section.

(ii) Immediate startup, shutdown, and malfunction reports. Notwithstanding the allowance to reduce the frequency of reporting for periodic startup, shutdown, and malfunction reports under paragraph (d)(5)(i) of this section, any time an action taken by an owner or operator during a startup or shutdown that caused the source to exceed any applicable emission limitation in the relevant emission standards, or malfunction (including actions taken to correct a malfunction) is not consistent with the procedures specified in the affected source's startup, shutdown, and malfunction plan, the owner or operator shall report the actions taken for that event within 2 working days after commencing actions inconsistent with the plan followed by a letter within 7 working days after the end of the event. The immediate report required under this paragraph (d)(5)(ii) shall consist of a telephone call (or facsimile (FAX) transmission) to the Administrator within 2 working days after commencing actions inconsistent with the plan, and it shall be followed by a letter, delivered or postmarked

SECTION E. Source Group Restrictions.

within 7 working days after the end of the event, that contains the name, title, and signature of the owner or operator or other responsible official who is certifying its accuracy, explaining the circumstances of the event, the reasons for not following the startup, shutdown, and malfunction plan, describing all excess emissions and/or parameter monitoring exceedances which are believed to have occurred (or could have occurred in the case of malfunctions), and actions taken to minimize emissions in conformance with §63.6(e)(1)(i). Notwithstanding the requirements of the previous sentence, after the effective date of an approved permit program in the State in which an affected source is located, the owner or operator may make alternative reporting arrangements, in advance, with the permitting authority in that State. Procedures governing the arrangement of alternative reporting requirements under this paragraph (d)(5)(ii) are specified in §63.9(i).

(e) Additional reporting requirements for sources with continuous monitoring systems—(1) General. When more than one CEMS is used to measure the emissions from one affected source (e.g., multiple breechings, multiple outlets), the owner or operator shall report the results as required for each CEMS.

(2) Reporting results of continuous monitoring system performance evaluations. (i) The owner or operator of an affected source required to install a CMS by a relevant standard shall furnish the Administrator a copy of a written report of the results of the CMS performance evaluation, as required under §63.8(e), simultaneously with the results of the performance test required under §63.7, unless otherwise specified in the relevant standard.

(ii) The owner or operator of an affected source using a COMS to determine opacity compliance during any performance test required under §63.7 and described in §63.6(d)(6) shall furnish the Administrator two or, upon request, three copies of a written report of the results of the COMS performance evaluation conducted under §63.8(e). The copies shall be furnished at least 15 calendar days before the performance test required under §63.7 is conducted.

(3) Excess emissions and continuous monitoring system performance report and summary report. (i) Excess emissions and parameter monitoring exceedances are defined in relevant standards. The owner or operator of an affected source required to install a CMS by a relevant standard shall submit an excess emissions and continuous monitoring system performance report and/or a summary report to the Administrator semiannually, except when—

(A) More frequent reporting is specifically required by a relevant standard;

(B) The Administrator determines on a case-by-case basis that more frequent reporting is necessary to accurately assess the compliance status of the source; or

(C) [Reserved]

(D) The affected source is complying with the Performance Track Provisions of §63.16, which allows less frequent reporting.

(ii) Request to reduce frequency of excess emissions and continuous monitoring system performance reports. Notwithstanding the frequency of reporting requirements specified in paragraph (e)(3)(i) of this section, an owner or operator who is required by a relevant standard to submit excess emissions and continuous monitoring system performance (and summary) reports on a quarterly (or more frequent) basis may reduce the frequency of reporting for that standard to semiannual if the following conditions are met:

(A) For 1 full year (e.g., 4 quarterly or 12 monthly reporting periods) the affected source's excess emissions and continuous monitoring system performance reports continually demonstrate that the source is in compliance with the relevant standard;

(B) The owner or operator continues to comply with all recordkeeping and monitoring requirements specified in this subpart and the relevant standard; and

(C) The Administrator does not object to a reduced frequency of reporting for the affected source, as provided in paragraph (e)(3)(iii) of this section.

(iii) The frequency of reporting of excess emissions and continuous monitoring system performance (and summary) reports required to comply with a relevant standard may be reduced only after the owner or operator notifies the Administrator in writing of his or her intention to make such a change and the Administrator does not object to the intended

**SECTION E. Source Group Restrictions.**

change. In deciding whether to approve a reduced frequency of reporting, the Administrator may review information concerning the source's entire previous performance history during the 5-year recordkeeping period prior to the intended change, including performance test results, monitoring data, and evaluations of an owner or operator's conformance with operation and maintenance requirements. Such information may be used by the Administrator to make a judgment about the source's potential for noncompliance in the future. If the Administrator disapproves the owner or operator's request to reduce the frequency of reporting, the Administrator will notify the owner or operator in writing within 45 days after receiving notice of the owner or operator's intention. The notification from the Administrator to the owner or operator will specify the grounds on which the disapproval is based. In the absence of a notice of disapproval within 45 days, approval is automatically granted.

(iv) As soon as CMS data indicate that the source is not in compliance with any emission limitation or operating parameter specified in the relevant standard, the frequency of reporting shall revert to the frequency specified in the relevant standard, and the owner or operator shall submit an excess emissions and continuous monitoring system performance (and summary) report for the noncomplying emission points at the next appropriate reporting period following the noncomplying event. After demonstrating ongoing compliance with the relevant standard for another full year, the owner or operator may again request approval from the Administrator to reduce the frequency of reporting for that standard, as provided for in paragraphs (e)(3)(ii) and (e)(3)(iii) of this section.

(v) Content and submittal dates for excess emissions and monitoring system performance reports. All excess emissions and monitoring system performance reports and all summary reports, if required, shall be delivered or postmarked by the 30th day following the end of each calendar half or quarter, as appropriate. Written reports of excess emissions or exceedances of process or control system parameters shall include all the information required in paragraphs (c)(5) through (c)(13) of this section, in §§63.8(c)(7) and 63.8(c)(8), and in the relevant standard, and they shall contain the name, title, and signature of the responsible official who is certifying the accuracy of the report. When no excess emissions or exceedances of a parameter have occurred, or a CMS has not been inoperative, out of control, repaired, or adjusted, such information shall be stated in the report.

(vi) Summary report. As required under paragraphs (e)(3)(vi) and (e)(3)(viii) of this section, one summary report shall be submitted for the hazardous air pollutants monitored at each affected source (unless the relevant standard specifies that more than one summary report is required, e.g., one summary report for each hazardous air pollutant monitored). The summary report shall be entitled "Summary Report—Gaseous and Opacity Excess Emission and Continuous Monitoring System Performance" and shall contain the following information:

(A) The company name and address of the affected source;

(B) An identification of each hazardous air pollutant monitored at the affected source;

(C) The beginning and ending dates of the reporting period;

(D) A brief description of the process units;

(E) The emission and operating parameter limitations specified in the relevant standard(s);

(F) The monitoring equipment manufacturer(s) and model number(s);

(G) The date of the latest CMS certification or audit;

(H) The total operating time of the affected source during the reporting period;

(I) An emission data summary (or similar summary if the owner or operator monitors control system parameters), including the total duration of excess emissions during the reporting period (recorded in minutes for opacity and hours for gases), the total duration of excess emissions expressed as a percent of the total source operating time during that reporting period, and a breakdown of the total duration of excess emissions during the reporting period into those that are due to startup/shutdown, control equipment problems, process problems, other known causes, and other unknown causes;

(J) A CMS performance summary (or similar summary if the owner or operator monitors control system parameters), including the total CMS downtime during the reporting period (recorded in minutes for opacity and hours for gases), the total

**SECTION E. Source Group Restrictions.**

- duration of CMS downtime expressed as a percent of the total source operating time during that reporting period, and a breakdown of the total CMS downtime during the reporting period into periods that are due to monitoring equipment malfunctions, nonmonitoring equipment malfunctions, quality assurance/quality control calibrations, other known causes, and other unknown causes;
- (K) A description of any changes in CMS, processes, or controls since the last reporting period;
- (L) The name, title, and signature of the responsible official who is certifying the accuracy of the report; and
- (M) The date of the report.
- (vi) If the total duration of excess emissions or process or control system parameter exceedances for the reporting period is less than 1 percent of the total operating time for the reporting period, and CMS downtime for the reporting period is less than 5 percent of the total operating time for the reporting period, only the summary report shall be submitted, and the full excess emissions and continuous monitoring system performance report need not be submitted unless required by the Administrator.
- (vii) If the total duration of excess emissions or process or control system parameter exceedances for the reporting period is 1 percent or greater of the total operating time for the reporting period, or the total CMS downtime for the reporting period is 5 percent or greater of the total operating time for the reporting period, both the summary report and the excess emissions and continuous monitoring system performance report shall be submitted.
- (4) Reporting continuous opacity monitoring system data produced during a performance test. The owner or operator of an affected source required to use a COMS shall record the monitoring data produced during a performance test required under §63.7 and shall furnish the Administrator a written report of the monitoring results. The report of COMS data shall be submitted simultaneously with the report of the performance test results required in paragraph (d)(2) of this section.
- (f) Waiver of recordkeeping or reporting requirements. (1) Until a waiver of a recordkeeping or reporting requirement has been granted by the Administrator under this paragraph, the owner or operator of an affected source remains subject to the requirements of this section.
- (2) Recordkeeping or reporting requirements may be waived upon written application to the Administrator if, in the Administrator's judgment, the affected source is achieving the relevant standard(s), or the source is operating under an extension of compliance, or the owner or operator has requested an extension of compliance and the Administrator is still considering that request.
- (3) If an application for a waiver of recordkeeping or reporting is made, the application shall accompany the request for an extension of compliance under §63.6(i), any required compliance progress report or compliance status report required under this part (such as under §§63.6(i) and 63.9(h)) or in the source's title V permit, or an excess emissions and continuous monitoring system performance report required under paragraph (e) of this section, whichever is applicable. The application shall include whatever information the owner or operator considers useful to convince the Administrator that a waiver of recordkeeping or reporting is warranted.
- (4) The Administrator will approve or deny a request for a waiver of recordkeeping or reporting requirements under this paragraph when he/she—
- (i) Approves or denies an extension of compliance; or
- (ii) Makes a determination of compliance following the submission of a required compliance status report or excess emissions and continuous monitoring systems performance report; or
- (iii) Makes a determination of suitable progress towards compliance following the submission of a compliance progress report, whichever is applicable.
- (5) A waiver of any recordkeeping or reporting requirement granted under this paragraph may be conditioned on other recordkeeping or reporting requirements deemed necessary by the Administrator.

**SECTION E. Source Group Restrictions.**

(6) Approval of any waiver granted under this section shall not abrogate the Administrator's authority under the Act or in any way prohibit the Administrator from later canceling the waiver. The cancellation will be made only after notice is given to the owner or operator of the affected source.

015 [40 CFR Part 63 NESHAPS for Source Categories §40 CFR Subpart 63.10032]

SUBPART UUUUU - National Emission Standards for Hazardous Air Pollutants: Coal- and Oil-Fired Electric Utility Steam Generating Units

What records must I keep?

(a) You must keep records according to paragraphs (a)(1) and (2) of this section. If you are required to (or elect to) continuously monitor Hg and/or HCl and/or HF emissions, you must also keep the records required under appendix A and/or appendix B to this subpart.

(1) A copy of each notification and report that you submitted to comply with this subpart, including all documentation supporting any Initial Notification or Notification of Compliance Status or semiannual compliance report that you submitted, according to the requirements in §63.10(b)(2)(xiv).

(2) Records of performance stack tests, fuel analyses, or other compliance demonstrations and performance evaluations, as required in §63.10(b)(2)(viii).

(b) Not applicable.

(c) You must keep the records required in Table 7 to this subpart including records of all monitoring data and calculated averages for applicable PMCPMS operating limits to show continuous compliance with each emission limit and operating limit that applies to you.

(d) For each EGU subject to an emission limit, you must also keep the records in paragraphs (d)(1) through (3) of this section.

(1) You must keep records of monthly fuel use by each EGU, including the type(s) of fuel and amount(s) used.

(2) Not applicable.

(3) For an EGU that qualifies as an LEE under §63.10005(h), you must keep annual records that document that your emissions in the previous stack test(s) continue to qualify the unit for LEE status for an applicable pollutant, and document that there was no change in source operations including fuel composition and operation of air pollution control equipment that would cause emissions of the pollutant to increase within the past year.

(e) If you elect to average emissions consistent with §63.10009, you must additionally keep a copy of the emissions averaging implementation plan required in §63.10009(g), all calculations required under §63.10009, including daily records of heat input or steam generation, as applicable, and monitoring records consistent with §63.10022.

(f) Regarding startup periods or shutdown periods:

(1) Should you choose to rely on paragraph (1) of the definition of "startup" in §63.10042 for your EGU, you must keep records of the occurrence and duration of each startup or shutdown.

(2) Not applicable.

(g) You must keep records of the occurrence and duration of each malfunction of an operation (i.e., process equipment) or the air pollution control and monitoring equipment.

(h) You must keep records of actions taken during periods of malfunction to minimize emissions in accordance with §63.10000(b), including corrective actions to restore malfunctioning process and air pollution control and monitoring equipment to its normal or usual manner of operation.

(i) You must keep records of the type(s) and amount(s) of fuel used during each startup or shutdown.

**SECTION E. Source Group Restrictions.**

(j) Not applicable.

016 [40 CFR Part 63 NESHAPS for Source Categories §40 CFR Subsection 63.10033]**SUBPART UUUUU - National Emission Standards for Hazardous Air Pollutants: Coal- and Oil-Fired Electric Utility Steam Generating Units****In what form and how long must I keep my records?**

(a) Your records must be in a form suitable and readily available for expeditious review, according to §63.10(b)(1).

(b) As specified in §63.10(b)(1), you must keep each record for 5 years following the date of each occurrence, measurement, maintenance, corrective action, report, or record.

(c) You must keep each record on site for at least 2 years after the date of each occurrence, measurement, maintenance, corrective action, report, or record, according to §63.10(b)(1). You can keep the records off site for the remaining 3 years.

V. REPORTING REQUIREMENTS.**# 017 [40 CFR Part 63 NESHAPS for Source Categories §40 CFR 63.13]****Subpart A--General Provisions****Addresses of State air pollution control agencies and EPA Regional Offices.**

(a) All requests, reports, applications, submittals, and other communications to the Administrator pursuant to this part shall be submitted to the appropriate Regional Office of the U.S. Environmental Protection Agency indicated in the following list of EPA Regional Offices.

EPA Region III (Delaware, District of Columbia, Maryland, Pennsylvania, Virginia, West Virginia), Director, Air Protection Division, 1650 Arch Street, Philadelphia, PA 19103.

(b) All information required to be submitted to the Administrator under this part also shall be submitted to the appropriate State agency of any State to which authority has been delegated under section 112(l) of the Act. The owner or operator of an affected source may contact the appropriate EPA Regional Office for the mailing addresses for those States whose delegation requests have been approved.

(c) If any State requires a submittal that contains all the information required in an application, notification, request, report, statement, or other communication required in this part, an owner or operator may send the appropriate Regional Office of the EPA a copy of that submittal to satisfy the requirements of this part for that communication.

018 [40 CFR Part 63 NESHAPS for Source Categories §40 CFR 63.9]**Subpart A--General Provisions****Notification requirements.**

(a) Applicability and general information. (1) The applicability of this section is set out in §63.1(a)(4).

(2) For affected sources that have been granted an extension of compliance under subpart D of this part, the requirements of this section do not apply to those sources while they are operating under such compliance extensions.

(3) If any State requires a notice that contains all the information required in a notification listed in this section, the owner or operator may send the Administrator a copy of the notice sent to the State to satisfy the requirements of this section for that notification.

(4)(i) Before a State has been delegated the authority to implement and enforce notification requirements established under this part, the owner or operator of an affected source in such State subject to such requirements shall submit notifications to the appropriate Regional Office of the EPA (to the attention of the Director of the Division indicated in the list of the EPA Regional Offices in §63.13).

(ii) After a State has been delegated the authority to implement and enforce notification requirements established under this part, the owner or operator of an affected source in such State subject to such requirements shall submit notifications to the delegated State authority (which may be the same as the permitting authority). In addition, if the delegated (permitting) authority is the State, the owner or operator shall send a copy of each notification submitted to the State to the appropriate Regional Office of the EPA, as specified in paragraph (a)(4)(i) of this section. The Regional Office may waive this

**SECTION E. Source Group Restrictions.**

requirement for any notifications at its discretion.

(b) Initial notifications. (1)(i) The requirements of this paragraph apply to the owner or operator of an affected source when such source becomes subject to a relevant standard.

(ii) If an area source that otherwise would be subject to an emission standard or other requirement established under this part if it were a major source subsequently increases its emissions of hazardous air pollutants (or its potential to emit hazardous air pollutants) such that the source is a major source that is subject to the emission standard or other requirement, such source shall be subject to the notification requirements of this section.

(iii) Affected sources that are required under this paragraph to submit an initial notification may use the application for approval of construction or reconstruction under §63.5(d) of this subpart, if relevant, to fulfill the initial notification requirements of this paragraph.

(2) The owner or operator of an affected source that has an initial startup before the effective date of a relevant standard under this part shall notify the Administrator in writing that the source is subject to the relevant standard. The notification, which shall be submitted not later than 120 calendar days after the effective date of the relevant standard (or within 120 calendar days after the source becomes subject to the relevant standard), shall provide the following information:

(i) The name and address of the owner or operator;

(ii) The address (i.e., physical location) of the affected source;

(iii) An identification of the relevant standard, or other requirement, that is the basis of the notification and the source's compliance date;

(iv) A brief description of the nature, size, design, and method of operation of the source and an identification of the types of emission points within the affected source subject to the relevant standard and types of hazardous air pollutants emitted; and

(v) A statement of whether the affected source is a major source or an area source.

(3) [Reserved]

(4) The owner or operator of a new or reconstructed major affected source for which an application for approval of construction or reconstruction is required under §63.5(d) must provide the following information in writing to the Administrator:

(i) A notification of intention to construct a new major-emitting affected source, reconstruct a major-emitting affected source, or reconstruct a major source such that the source becomes a major-emitting affected source with the application for approval of construction or reconstruction as specified in §63.5(d)(1)(i); and

(ii)-(iv) [Reserved]

(v) A notification of the actual date of startup of the source, delivered or postmarked within 15 calendar days after that date.

(5) The owner or operator of a new or reconstructed affected source for which an application for approval of construction or reconstruction is not required under §63.5(d) must provide the following information in writing to the Administrator:

(i) A notification of intention to construct a new affected source, reconstruct an affected source, or reconstruct a source such that the source becomes an affected source, and

(ii) A notification of the actual date of startup of the source, delivered or postmarked within 15 calendar days after that date.

(iii) Unless the owner or operator has requested and received prior permission from the Administrator to submit less than the information in §63.5(d), the notification must include the information required on the application for approval of construction or reconstruction as specified in §63.5(d)(1)(i).

**SECTION E. Source Group Restrictions.**

(c)-(d) Not applicable.

(e) Notification of performance test. The owner or operator of an affected source shall notify the Administrator in writing of his or her intention to conduct a performance test at least 60 calendar days before the performance test is scheduled to begin to allow the Administrator to review and approve the site-specific test plan required under §63.7(c), if requested by the Administrator, and to have an observer present during the test.

(f) Not applicable.

(g) Additional notification requirements for sources with continuous monitoring systems. The owner or operator of an affected source required to use a CMS by a relevant standard shall furnish the Administrator written notification as follows:

(1) A notification of the date the CMS performance evaluation under §63.8(e) is scheduled to begin, submitted simultaneously with the notification of the performance test date required under §63.7(b). If no performance test is required, or if the requirement to conduct a performance test has been waived for an affected source under §63.7(h), the owner or operator shall notify the Administrator in writing of the date of the performance evaluation at least 60 calendar days before the evaluation is scheduled to begin;

(2) A notification that COMS data results will be used to determine compliance with the applicable opacity emission standard during a performance test required by §63.7 in lieu of Method 9 or other opacity emissions test method data, as allowed by §63.6(h)(7)(ii), if compliance with an opacity emission standard is required for the source by a relevant standard. The notification shall be submitted at least 60 calendar days before the performance test is scheduled to begin; and

(3) A notification that the criterion necessary to continue use of an alternative to relative accuracy testing, as provided by §63.8(f)(6), has been exceeded. The notification shall be delivered or postmarked not later than 10 days after the occurrence of such exceedance, and it shall include a description of the nature and cause of the increased emissions.

(h) Notification of compliance status. (1) The requirements of paragraphs (h)(2) through (h)(4) of this section apply when an affected source becomes subject to a relevant standard.

(2)(i) Before a title V permit has been issued to the owner or operator of an affected source, and each time a notification of compliance status is required under this part, the owner or operator of such source shall submit to the Administrator a notification of compliance status, signed by the responsible official who shall certify its accuracy, attesting to whether the source has complied with the relevant standard. The notification shall list—

(A) The methods that were used to determine compliance;

(B) The results of any performance tests, opacity or visible emission observations, continuous monitoring system (CMS) performance evaluations, and/or other monitoring procedures or methods that were conducted;

(C) The methods that will be used for determining continuing compliance, including a description of monitoring and reporting requirements and test methods;

(D) The type and quantity of hazardous air pollutants emitted by the source (or surrogate pollutants if specified in the relevant standard), reported in units and averaging times and in accordance with the test methods specified in the relevant standard;

(E) If the relevant standard applies to both major and area sources, an analysis demonstrating whether the affected source is a major source (using the emissions data generated for this notification);

(F) A description of the air pollution control equipment (or method) for each emission point, including each control device (or method) for each hazardous air pollutant and the control efficiency (percent) for each control device (or method); and

(G) A statement by the owner or operator of the affected existing, new, or reconstructed source as to whether the source has complied with the relevant standard or other requirements.

(ii) The notification must be sent before the close of business on the 60th day following the completion of the relevant

**SECTION E. Source Group Restrictions.**

compliance demonstration activity specified in the relevant standard (unless a different reporting period is specified in the standard, in which case the letter must be sent before the close of business on the day the report of the relevant testing or monitoring results is required to be delivered or postmarked). For example, the notification shall be sent before close of business on the 60th (or other required) day following completion of the initial performance test and again before the close of business on the 60th (or other required) day following the completion of any subsequent required performance test. If no performance test is required but opacity or visible emission observations are required to demonstrate compliance with an opacity or visible emission standard under this part, the notification of compliance status shall be sent before close of business on the 30th day following the completion of opacity or visible emission observations. Notifications may be combined as long as the due date requirement for each notification is met.

(3) After a title V permit has been issued to the owner or operator of an affected source, the owner or operator of such source shall comply with all requirements for compliance status reports contained in the source's title V permit, including reports required under this part. After a title V permit has been issued to the owner or operator of an affected source, and each time a notification of compliance status is required under this part, the owner or operator of such source shall submit the notification of compliance status to the appropriate permitting authority following completion of the relevant compliance demonstration activity specified in the relevant standard.

(4) [Reserved]

(5) If an owner or operator of an affected source submits estimates or preliminary information in the application for approval of construction or reconstruction required in §63.5(d) in place of the actual emissions data or control efficiencies required in paragraphs (d)(1)(ii)(H) and (d)(2) of §63.5, the owner or operator shall submit the actual emissions data and other correct information as soon as available but no later than with the initial notification of compliance status required in this section.

(6) Advice on a notification of compliance status may be obtained from the Administrator.

(i) Adjustment to time periods or postmark deadlines for submittal and review of required communications. (1)(i) Until an adjustment of a time period or postmark deadline has been approved by the Administrator under paragraphs (i)(2) and (i)(3) of this section, the owner or operator of an affected source remains strictly subject to the requirements of this part.

(ii) An owner or operator shall request the adjustment provided for in paragraphs (i)(2) and (i)(3) of this section each time he or she wishes to change an applicable time period or postmark deadline specified in this part.

(2) Notwithstanding time periods or postmark deadlines specified in this part for the submittal of information to the Administrator by an owner or operator, or the review of such information by the Administrator, such time periods or deadlines may be changed by mutual agreement between the owner or operator and the Administrator. An owner or operator who wishes to request a change in a time period or postmark deadline for a particular requirement shall request the adjustment in writing as soon as practicable before the subject activity is required to take place. The owner or operator shall include in the request whatever information he or she considers useful to convince the Administrator that an adjustment is warranted.

(3) If, in the Administrator's judgment, an owner or operator's request for an adjustment to a particular time period or postmark deadline is warranted, the Administrator will approve the adjustment. The Administrator will notify the owner or operator in writing of approval or disapproval of the request for an adjustment within 15 calendar days of receiving sufficient information to evaluate the request.

(4) If the Administrator is unable to meet a specified deadline, he or she will notify the owner or operator of any significant delay and inform the owner or operator of the amended schedule.

(j) Change in information already provided. Any change in the information already provided under this section shall be provided to the Administrator in writing within 15 calendar days after the change.

019 [40 CFR Part 63 NESHAPS for Source Categories §40 CFR Subpart 63.10021]

SUBPART UUUUU - National Emission Standards for Hazardous Air Pollutants: Coal- and Oil-Fired Electric Utility Steam Generating Units

How do I demonstrate continuous compliance with the emission limitations, operating limits, and work practice standards?

**SECTION E. Source Group Restrictions.**

(a)-(d) [See VII. Additional Requirements for this source group.]

(e) [See VI. Work Practice Requirements for this source group.]

(f) You must submit the reports required under §63.10031 and, if applicable, the reports required under appendices A and B to this subpart. The electronic reports required by appendices A and B to this subpart must be sent to the Administrator electronically in a format prescribed by the Administrator, as provided in §63.10031. CEMS data (except for PM CEMS and any approved alternative monitoring using a HAP metals CEMS) shall be submitted using EPA's Emissions Collection and Monitoring Plan System (ECMPS) Client Tool. Other data, including PM CEMS data, HAP metals CEMS data, and CEMS performance test detail reports, shall be submitted in the file format generated through use of EPA's Electronic Reporting Tool, the Compliance and Emissions Data Reporting Interface, or alternate electronic file format, all as provided for under §63.10031.

(g) You must report each instance in which you did not meet an applicable emissions limit or operating limit in Tables 1 through 4 to this subpart or failed to conduct a required tune-up. These instances are deviations from the requirements of this subpart. These deviations must be reported according to §63.10031.

(h) [See VI. Work Practice Requirements for this source group.]

(i) You must provide reports as specified in §63.10031 concerning activities and periods of startup and shutdown.

020 [40 CFR Part 63 NESHAPS for Source Categories §40 CFR Subpart 63.10030]

SUBPART UUUUU - National Emission Standards for Hazardous Air Pollutants: Coal- and Oil-Fired Electric Utility Steam Generating Units

What notifications must I submit and when?

(a) You must submit all of the notifications in §§63.7(b) and (c), 63.8 (e), (f)(4) and (6), and 63.9 (b) through (h) that apply to you by the dates specified.

(b) As specified in §63.9(b)(2), if you startup your EGU that is an affected source before April 16, 2012, you must submit an Initial Notification not later than 120 days after April 16, 2012.

(c) Not applicable.

(d) When you are required to conduct a performance test, you must submit a Notification of Intent to conduct a performance test at least 30 days before the performance test is scheduled to begin.

(e) When you are required to conduct an initial compliance demonstration as specified in §63.10011(a), you must submit a Notification of Compliance Status according to §63.9(h)(2)(ii). The Notification of Compliance Status report must contain all the information specified in paragraphs (e)(1) through (8) of this section, as applicable.

(1) A description of the affected source(s), including identification of the subcategory of the source, the design capacity of the source, a description of the add-on controls used on the source, description of the fuel(s) burned, including whether the fuel(s) were determined by you or EPA through a petition process to be a non-waste under 40 CFR 241.3, whether the fuel(s) were processed from discarded non-hazardous secondary materials within the meaning of 40 CFR 241.3, and justification for the selection of fuel(s) burned during the performance test.

(2) Summary of the results of all performance tests and fuel analyses and calculations conducted to demonstrate initial compliance including all established operating limits.

(3) Identification of whether you plan to demonstrate compliance with each applicable emission limit through performance testing; fuel moisture analyses; performance testing with operating limits (e.g., use of PM CPMS); CEMS; or a sorbent trap monitoring system.

(4) Identification of whether you plan to demonstrate compliance by emissions averaging.

(5) A signed certification that you have met all applicable emission limits and work practice standards.

**SECTION E. Source Group Restrictions.**

(6) If you had a deviation from any emission limit, work practice standard, or operating limit, you must also submit a brief description of the deviation, the duration of the deviation, emissions point identification, and the cause of the deviation in the Notification of Compliance Status report.

(7) In addition to the information required in §63.9(h)(2), your notification of compliance status must include the following:

(i) A summary of the results of the annual performance tests and documentation of any operating limits that were reestablished during this test, if applicable. If you are conducting stack tests once every 3 years consistent with §63.10005(h)(1)(i), the date of each stack test conducted during the previous 3 years, a comparison of emission level you achieved in each stack test conducted during the previous 3 years to the 50 percent emission limit threshold required in §63.10006(i), and a statement as to whether there have been any operational changes since the last stack test that could increase emissions.

(ii) Certifications of compliance, as applicable, and must be signed by a responsible official stating:

(A) "This EGU complies with the requirements in §63.10021(a) to demonstrate continuous compliance." and

(B) "No secondary materials that are solid waste were combusted in any affected unit."

(iii) For each of your existing EGUs, identification of each emissions limit as specified in Table 2 to this subpart with which you plan to comply.

(A) You may switch from a mass per heat input to a mass per gross output limit (or vice-versa), provided that:

(1) You submit a request that identifies for each EGU or EGU emissions averaging group involved in the proposed switch both the current and proposed emission limit;

(2) Your request arrives to the Administrator at least 30 calendar days prior to the date that the switch is proposed to occur;

(3) Your request demonstrates through performance stack test results completed within 30 days prior to your submission, compliance for each EGU or EGU emissions averaging group with both the mass per heat input and mass per gross output limits;

(4) You revise and submit all other applicable plans, e.g., monitoring and emissions averaging, with your request; and

(5) You maintain records of all information regarding your choice of emission limits.

(B) You begin to use the revised emission limits starting in the next reporting period, after receipt of written acknowledgement from the Administrator of the switch.

(C) From submission of your request until start of the next reporting period after receipt of written acknowledgement from the Administrator of the switch, you demonstrate compliance with both the mass per heat input and mass per gross output emission limits for each pollutant for each EGU or EGU emissions averaging group.

(8) Identification of whether you plan to rely on paragraph (1) or (2) of the definition of "startup" in §63.10042.

(i)-(ii) Not applicable.

(iii) You may switch from paragraph (1) of the definition of "startup" in §63.10042 to paragraph (2) of the definition of "startup" (or vice-versa), provided that:

(A) You submit a request that identifies for each EGU or EGU emissions averaging group involved in the proposed switch both the current definition of "startup" relied on and the proposed definition you plan to rely on;

(B) Your request arrives to the Administrator at least 30 calendar days prior to the date that the switch is proposed to occur;

(C) You revise and submit all other applicable plans, e.g., monitoring and emissions averaging, with your submission;

**SECTION E. Source Group Restrictions.**

(D) You maintain records of all information regarding your choice of the definition of “startup”; and

(E) You begin to use the revised definition of “startup” in the next reporting period after receipt of written acknowledgement from the Administrator of the switch.

(f) You must submit the notifications in §63.10000(h)(2) and (i)(2) that may apply to you by the dates specified.

021 [40 CFR Part 63 NESHAPS for Source Categories §40 CFR Subpart 63.10031]

SUBPART UUUUU - National Emission Standards for Hazardous Air Pollutants: Coal- and Oil-Fired Electric Utility Steam Generating Units

What reports must I submit and when?

(a) You must submit each report in Table 8 to this subpart that applies to you. If you are required to (or elect to) continuously monitor Hg and/or HCl and/or HF emissions, you must also submit the electronic reports required under appendix A and/or appendix B to the subpart, at the specified frequency.

(b) Unless the Administrator has approved a different schedule for submission of reports under §63.10(a), you must submit each report by the date in Table 8 to this subpart and according to the requirements in paragraphs (b)(1) through (5) of this section.

(1) The first compliance report must cover the period beginning on the compliance date that is specified for your affected source in §63.9984 and ending on June 30 or December 31, whichever date is the first date that occurs at least 180 days after the compliance date that is specified for your source in §63.9984.

(2) The first compliance report must be postmarked or submitted electronically no later than July 31 or January 31, whichever date is the first date following the end of the first calendar half after the compliance date that is specified for your source in §63.9984.

(3) Each subsequent compliance report must cover the semiannual reporting period from January 1 through June 30 or the semiannual reporting period from July 1 through December 31.

(4) Each subsequent compliance report must be postmarked or submitted electronically no later than July 31 or January 31, whichever date is the first date following the end of the semiannual reporting period.

(5) For each affected source that is subject to permitting regulations pursuant to part 70 or part 71 of this chapter, and if the permitting authority has established dates for submitting semiannual reports pursuant to 40 CFR 70.6(a)(3)(iii)(A) or 40 CFR 71.6(a)(3)(iii)(A), you may submit the first and subsequent compliance reports according to the dates the permitting authority has established instead of according to the dates in paragraphs (b)(1) through (4) of this section.

(c) The compliance report must contain the information required in paragraphs (c)(1) through (9) of this section.

(1) The information required by the summary report located in 63.10(e)(3)(vi).

(2) The total fuel use by each affected source subject to an emission limit, for each calendar month within the semiannual reporting period, including, but not limited to, a description of the fuel, whether the fuel has received a non-waste determination by EPA or your basis for concluding that the fuel is not a waste, and the total fuel usage amount with units of measure.

(3) Indicate whether you burned new types of fuel during the reporting period. If you did burn new types of fuel you must include the date of the performance test where that fuel was in use.

(4) Include the date of the most recent tune-up for each EGU. The date of the tune-up is the date the tune-up provisions specified in §63.10021(e)(6) and (7) were completed.

(5)-(6) Not applicable.

(7) A summary of the results of the annual performance tests and documentation of any operating limits that were reestablished during the test, if applicable. If you are conducting stack tests once every 3 years to maintain LEE status,

**SECTION E. Source Group Restrictions.**

consistent with §63.10006(b), the date of each stack test conducted during the previous 3 years, a comparison of emission level you achieved in each stack test conducted during the previous 3 years to the 50 percent emission limit threshold required in §63.10005(h)(1)(i), and a statement as to whether there have been any operational changes since the last stack test that could increase emissions.

(8) A certification.

(9) If you have a deviation from any emission limit, work practice standard, or operating limit, you must also submit a brief description of the deviation, the duration of the deviation, emissions point identification, and the cause of the deviation.

(d) Not applicable.

(e) Each affected source that has obtained a Title V operating permit pursuant to part 70 or part 71 of this chapter must report all deviations as defined in this subpart in the semiannual monitoring report required by 40 CFR 70.6(a)(3)(iii)(A) or 40 CFR 71.6(a)(3)(iii)(A). If an affected source submits a compliance report pursuant to Table 8 to this subpart along with, or as part of, the semiannual monitoring report required by 40 CFR 70.6(a)(3)(iii)(A) or 40 CFR 71.6(a)(3)(iii)(A), and the compliance report includes all required information concerning deviations from any emission limit, operating limit, or work practice requirement in this subpart, submission of the compliance report satisfies any obligation to report the same deviations in the semiannual monitoring report. Submission of a compliance report does not otherwise affect any obligation the affected source may have to report deviations from permit requirements to the permit authority.

(f) On or after July 1, 2020, within 60 days after the date of completing each performance test, you must submit the performance test reports required by this subpart to the EPA's WebFIRE database by using the Compliance and Emissions Data Reporting Interface (CEDRI) that is accessed through the EPA's Central Data Exchange (CDX) (<https://cdx.epa.gov>). Performance test data must be submitted in the file format generated through use of EPA's Electronic Reporting Tool (ERT) (see <https://www.epa.gov/ttn/chief/ert/index.html>). Only data collected using those test methods on the ERT website are subject to this requirement for submitting reports electronically to WebFIRE. Owners or operators who claim that some of the information being submitted for performance tests is confidential business information (CBI) must submit a complete ERT file including information claimed to be CBI on a compact disk or other commonly used electronic storage media (including, but not limited to, flash drives) to EPA. The electronic media must be clearly marked as CBI and mailed to U.S. EPA/OAPQS/CORE CBI Office, Attention: WebFIRE Administrator, MD C404-02, 4930 Old Page Rd., Durham, NC 27703. The same ERT file with the CBI omitted must be submitted to EPA via CDX as described earlier in this paragraph. At the discretion of the delegated authority, you must also submit these reports, including the confidential business information, to the delegated authority in the format specified by the delegated authority.

(1) On or after July 1, 2020, within 60 days after the date of completing each CEMS (SO₂, PM, HCl, HF, and Hg) performance evaluation test, as defined in §63.2 and required by this subpart, you must submit the relative accuracy test audit (RATA) data (or, for PM CEMS, RCA and RRA data) required by this subpart to EPA's WebFIRE database by using CEDRI that is accessed through EPA's CDX (<https://cdx.epa.gov>). The RATA data shall be submitted in the file format generated through use of EPA's Electronic Reporting Tool (ERT) (<https://www.epa.gov/ttn/chief/ert/index.html>). Only RATA data compounds listed on the ERT website are subject to this requirement. Owners or operators who claim that some of the information being submitted for RATAs is confidential business information (CBI) shall submit a complete ERT file including information claimed to be CBI on a compact disk or other commonly used electronic storage media (including, but not limited to, flash drives) by registered letter to EPA and the same ERT file with the CBI omitted to EPA via CDX as described earlier in this paragraph. The compact disk or other commonly used electronic storage media shall be clearly marked as CBI and mailed to U.S. EPA/OAPQS/CORE CBI Office, Attention: WebFIRE Administrator, MD C404-02, 4930 Old Page Rd., Durham, NC 27703. At the discretion of the delegated authority, owners or operators shall also submit these RATAs to the delegated authority in the format specified by the delegated authority. Owners or operators shall submit calibration error testing, drift checks, and other information required in the performance evaluation as described in §63.2 and as required in this chapter.

(2) Not applicable.

(3) Reports for an SO₂ CEMS, a Hg CEMS or sorbent trap monitoring system, an HCl or HF CEMS, and any supporting monitors for such systems (such as a diluent or moisture monitor) shall be submitted using the ECMPs Client Tool, as provided for in Appendices A and B to this subpart and §63.10021(f).

**SECTION E. Source Group Restrictions.**

(4) On or after July 1, 2020, submit the compliance reports required under paragraphs (c) and (d) of this section and the notification of compliance status required under §63.10030(e) to the EPA's WebFIRE database by using the CEDRI that is accessed through the EPA's CDX (<https://cdx.epa.gov>). You must use the appropriate electronic reporting form in CEDRI or provide an alternate electronic file consistent with EPA's reporting form output format.

(5) All reports required by this subpart not subject to the requirements in paragraphs (f) introductory text and (f)(1) through (4) of this section must be sent to the Administrator at the appropriate address listed in §63.13. If acceptable to both the Administrator and the owner or operator of an EGU, these reports may be submitted on electronic media. The Administrator retains the right to require submittal of reports subject to paragraphs (f) introductory text and (f)(1) through (4) of this section in paper format.

(6) Prior to July 1, 2020, all reports subject to electronic submittal in paragraphs (f) introductory text, (f)(1), (2), and (4) of this section shall be submitted to the EPA at the frequency specified in those paragraphs in electronic portable document format (PDF) using the ECMPS Client Tool. Each PDF version of a submitted report must include sufficient information to assess compliance and to demonstrate that the testing was done properly. The following data elements must be entered into the ECMPS Client Tool at the time of submission of each PDF file:

(i) The facility name, physical address, mailing address (if different from the physical address), and county;

(ii) The ORIS code (or equivalent ID number assigned by EPA's Clean Air Markets Division (CAMD)) and the Facility Registry System (FRS) ID;

(iii) The EGU (or EGUs) to which the report applies. Report the EGU IDs as they appear in the CAMD Business System;

(iv) If any of the EGUs in paragraph (f)(6)(iii) of this section share a common stack, indicate which EGUs share the stack. If emissions data are monitored and reported at the common stack according to part 75 of this chapter, report the ID number of the common stack as it is represented in the electronic monitoring plan required under §75.53 of this chapter;

(v) If any of the EGUs described in paragraph (f)(6)(iii) of this section are in an averaging plan under §63.10009, indicate which EGUs are in the plan and whether it is a 30- or 90-day averaging plan;

(vi) The identification of each emission point to which the report applies. An "emission point" is a point at which source effluent is released to the atmosphere, and is either a dedicated stack that serves one of the EGUs identified in paragraph (f)(6)(iii) of this section or a common stack that serves two or more of those EGUs. To identify an emission point, associate it with the EGU or stack ID in the CAMD Business system or the electronic monitoring plan (e.g., "Unit 2 stack," "common stack CS001," or "multiple stack MS001");

(vii) The rule citation (e.g., §63.10031(f)(1), §63.10031(f)(2), etc.) for which the report is showing compliance;

(viii) The pollutant(s) being addressed in the report;

(ix) The reporting period being covered by the report (if applicable);

(x) The relevant test method that was performed for a performance test (if applicable);

(xi) The date the performance test was conducted (if applicable); and

(xii) The responsible official's name, title, and phone number.

(g) If you had a malfunction during the reporting period, the compliance report must include the number, duration, and a brief description for each type of malfunction which occurred during the reporting period and which caused or may have caused any applicable emission limitation to be exceeded.

022 [40 CFR Part 63 NESHAPS for Source Categories §Table 8 to Subpart UUUUU]

SUBPART UUUUU - National Emission Standards for Hazardous Air Pollutants: Coal- and Oil-Fired Electric Utility Steam Generating Units Reporting Requirements

**SECTION E. Source Group Restrictions.**

As stated in §63.10031, you must comply with the following requirements for reports:

You must submit a compliance report semiannually according to the requirements in §63.10031(b) containing:

(a) Information required in §63.10031(c)(1) through (9); and

(b) If there are no deviations from any emission limitation (emission limit and operating limit) that applies to you and there are no deviations from the requirements for work practice standards in Table 3 to this subpart that apply to you, a statement that there were no deviations from the emission limitations and work practice standards during the reporting period. If there were no periods during which the CMSs, including continuous emissions monitoring system, and operating parameter monitoring systems, were out-of-control as specified in §63.8(c)(7), a statement that there were no periods during which the CMSs were out-of-control during the reporting period; and

(c) If you have a deviation from any emission limitation (emission limit and operating limit) or work practice standard during the reporting period, the report must contain the information in §63.10031(d). If there were periods during which the CMSs, including continuous emissions monitoring systems and continuous parameter monitoring systems, were out-of-control, as specified in §63.8(c)(7), the report must contain the information in §63.10031(e).

VI. WORK PRACTICE REQUIREMENTS.

023 [40 CFR Part 63 NESHAPS for Source Categories §40 CFR Subpart 63.10021]

SUBPART UUUUU - National Emission Standards for Hazardous Air Pollutants: Coal- and Oil-Fired Electric Utility Steam Generating Units

How do I demonstrate continuous compliance with the emission limitations, operating limits, and work practice standards?

(a)-(d) [See VII. Additional Requirements for this source group.]

(e) Conduct periodic performance tune-ups of your EGU(s), as specified in paragraphs (e)(1) through (9) of this section. For your first tune-up, you may perform the burner inspection any time prior to the tune-up or you may delay the first burner inspection until the next scheduled EGU outage provided you meet the requirements of §63.10005. Subsequently, you must perform an inspection of the burner at least once every 36 calendar months unless your EGU employs neural network combustion optimization during normal operations in which case you must perform an inspection of the burner and combustion controls at least once every 48 calendar months. If your EGU is offline when a deadline to perform the tune-up passes, you shall perform the tune-up work practice requirements within 30 days after the re-start of the affected unit.

(1) As applicable, inspect the burner and combustion controls, and clean or replace any components of the burner or combustion controls as necessary upon initiation of the work practice program and at least once every required inspection period. Repair of a burner or combustion control component requiring special order parts may be scheduled as follows:

(i) Burner or combustion control component parts needing replacement that affect the ability to optimize NOX and CO must be installed within 3 calendar months after the burner inspection,

(ii) Burner or combustion control component parts that do not affect the ability to optimize NOX and CO may be installed on a schedule determined by the operator;

(2) As applicable, inspect the flame pattern and make any adjustments to the burner or combustion controls necessary to optimize the flame pattern. The adjustment should be consistent with the manufacturer's specifications, if available, or in accordance with best combustion engineering practice for that burner type;

(3) As applicable, observe the damper operations as a function of mill and/or cyclone loadings, cyclone and pulverizer coal feeder loadings, or other pulverizer and coal mill performance parameters, making adjustments and effecting repair to dampers, controls, mills, pulverizers, cyclones, and sensors;

(4) As applicable, evaluate windbox pressures and air proportions, making adjustments and effecting repair to dampers, actuators, controls, and sensors;

(5) Inspect the system controlling the air-to-fuel ratio and ensure that it is correctly calibrated and functioning properly. Such inspection may include calibrating excess O₂ probes and/or sensors, adjusting overfire air systems, changing software

**SECTION E. Source Group Restrictions.**

parameters, and calibrating associated actuators and dampers to ensure that the systems are operated as designed. Any component out of calibration, in or near failure, or in a state that is likely to negate combustion optimization efforts prior to the next tune-up, should be corrected or repaired as necessary;

(6) Optimize combustion to minimize generation of CO and NOX. This optimization should be consistent with the manufacturer's specifications, if available, or best combustion engineering practice for the applicable burner type. NOX optimization includes burners, overfire air controls, concentric firing system improvements, neural network or combustion efficiency software, control systems calibrations, adjusting combustion zone temperature profiles, and add-on controls such as SCR and SNCR; CO optimization includes burners, overfire air controls, concentric firing system improvements, neural network or combustion efficiency software, control systems calibrations, and adjusting combustion zone temperature profiles;

(7) While operating at full load or the predominantly operated load, measure the concentration in the effluent stream of CO and NOX in ppm, by volume, and oxygen in volume percent, before and after the tune-up adjustments are made (measurements may be either on a dry or wet basis, as long as it is the same basis before and after the adjustments are made). You may use portable CO, NOX and O2 monitors for this measurement. EGU's employing neural network optimization systems need only provide a single pre- and post-tune-up value rather than continual values before and after each optimization adjustment made by the system;

(8) Maintain on-site and submit, if requested by the Administrator, an annual report containing the information in paragraphs (e)(1) through (e)(9) of this section including:

(i) The concentrations of CO and NOX in the effluent stream in ppm by volume, and oxygen in volume percent, measured before and after an adjustment of the EGU combustion systems;

(ii) A description of any corrective actions taken as a part of the combustion adjustment; and

(iii) The type(s) and amount(s) of fuel used over the 12 calendar months prior to an adjustment, but only if the unit was physically and legally capable of using more than one type of fuel during that period; and

(9) Report the dates of the initial and subsequent tune-ups in hard copy, as specified in §63.10031(f)(5), through June 30, 2020. On or after July 1, 2020, report the date of all tune-ups electronically, in accordance with §63.10031(f). The tune-up report date is the date when tune-up requirements in paragraphs (e)(6) and (7) of this section are completed.

(f)-(g) [See V. Reporting Requirements for this source group.]

(h) You must follow the startup or shutdown requirements as given in Table 3 to this subpart for each coal-fired, liquid oil-fired, or solid oil-derived fuel-fired EGU.

(1) You may use the diluent cap and default gross output values, as described in §63.10007(f), during startup periods or shutdown periods.

(2) You must operate all CMS, collect data, calculate pollutant emission rates, and record data during startup periods or shutdown periods.

(3) You must report the information as required in §63.10031.

(4) You may choose to submit an alternative non-opacity emission standard, in accordance with the requirements contained in §63.10011(g)(4). Until promulgation in the Federal Register of the final alternative non-opacity emission standard, you shall comply with paragraph (1) of the definition of "startup" in §63.10042.

(i) [See V. Reporting Requirements for this source group.]

024 [40 CFR Part 63 NESHAPS for Source Categories §Table 3 to Subpart UUUUU of Part 63]

SUBPART UUUUU - National Emission Standards for Hazardous Air Pollutants: Coal- and Oil-Fired Electric Utility Steam Generating Units

Work Practice Standards

**SECTION E. Source Group Restrictions.**

As stated in §§63.9991, you must comply with the following applicable work practice standards:

If your EGU is

1. An existing EGU, you must conduct a tune-up of the EGU burner and combustion controls at least each 36 calendar months, or each 48 calendar months if neural network combustion optimization software is employed, as specified in §63.10021(e).

2. Not applicable.

3. A coal-fired, liquid oil-fired (excluding limited-use liquid oil-fired subcategory units), or solid oil-derived fuel-fired EGU during startup, you must:

a. You have the option of complying using either of the following work practice standards:

(1) If you choose to comply using paragraph (1) of the definition of "startup" in §63.10042, you must operate all CMS during startup. Startup means either the first-ever firing of fuel in a boiler for the purpose of producing electricity, or the firing of fuel in a boiler after a shutdown event for any purpose. Startup ends when any of the steam from the boiler is used to generate electricity for sale over the grid or for any other purpose (including on site use). For startup of a unit, you must use clean fuels as defined in §63.10042 for ignition. Once you convert to firing coal, residual oil, or solid oil-derived fuel, you must engage all of the applicable control technologies except dry scrubber and SCR. You must start your dry scrubber and SCR systems, if present, appropriately to comply with relevant standards applicable during normal operation. You must comply with all applicable emissions limits at all times except for periods that meet the applicable definitions of startup and shutdown in this subpart. You must keep records during startup periods. You must provide reports concerning activities and startup periods, as specified in §63.10011(g) and §63.10021(h) and (i).

(2) If you choose to comply using paragraph (2) of the definition of "startup" in §63.10042, you must operate all CMS during startup. You must also collect appropriate data, and you must calculate the pollutant emission rate for each hour of startup.

For startup of an EGU, you must use one or a combination of the clean fuels defined in §63.10042 to the maximum extent possible, taking into account considerations such as boiler or control device integrity, throughout the startup period. You must have sufficient clean fuel capacity to engage and operate your PM control device within one hour of adding coal, residual oil, or solid oil-derived fuel to the unit. You must meet the startup period work practice requirements as identified in §63.10020(e).

Once you start firing coal, residual oil, or solid oil-derived fuel, you must vent emissions to the main stack(s). You must comply with the applicable emission limits beginning with the hour after startup ends. You must engage and operate your particulate matter control(s) within 1 hour of first firing of coal, residual oil, or solid oil-derived fuel.

You must start all other applicable control devices as expeditiously as possible, considering safety and manufacturer/supplier recommendations, but, in any case, when necessary to comply with other standards made applicable to the EGU by a permit limit or a rule other than this Subpart that require operation of the control devices.

b. Not applicable.

c. If you choose to use just one set of sorbent traps to demonstrate compliance with the applicable Hg emission limit, you must comply with the limit at all times; otherwise, you must comply with the applicable emission limit at all times except for startup and shutdown periods.

d. You must collect monitoring data during startup periods, as specified in §63.10020(a) and (e). You must keep records during startup periods, as provided in §§63.10032 and 63.10021(h). You must provide reports concerning activities and startup periods, as specified in §§63.10011(g), 63.10021(i), and 63.10031.

4. A coal-fired, liquid oil-fired (excluding limited-use liquid oil-fired subcategory units), or solid oil-derived fuel-fired EGU during shutdown, you must:

You must operate all CMS during shutdown. You must also collect appropriate data, and you must calculate the pollutant emission rate for each hour of shutdown for those pollutants for which a CMS is used.

While firing coal, residual oil, or solid oil-derived fuel during shutdown, you must vent emissions to the main stack(s) and operate all applicable control devices and continue to operate those control devices after the cessation of coal, residual oil, or solid oil-derived fuel being fed into the EGU and for as long as possible thereafter considering operational and safety concerns. In any case, you must operate your controls when necessary to comply with other standards made applicable to the EGU by a permit limit or a rule other than this Subpart and that require operation of the control devices.

If, in addition to the fuel used prior to initiation of shutdown, another fuel must be used to support the shutdown process, that additional fuel must be one or a combination of the clean fuels defined in §63.10042 and must be used to the maximum extent possible, taking into account considerations such as not compromising boiler or control device integrity.

Relative to the syngas not fired in the combustion turbine of an IGCC EGU during shutdown, you must either: (1) Flare the syngas, or (2) route the syngas to duct burners, which may need to be installed, and route the flue gas from the duct burners to the heat recovery steam generator.

**SECTION E. Source Group Restrictions.**

You must comply with all applicable emission limits at all times except during startup periods and shutdown periods at which time you must meet this work practice. You must collect monitoring data during shutdown periods, as specified in §63.10020(a). You must keep records during shutdown periods, as provided in §§63.10032 and 63.10021(h). Any fraction of an hour in which shutdown occurs constitutes a full hour of shutdown. You must provide reports concerning activities and shutdown periods, as specified in §§63.10011(g), 63.10021(i), and 63.10031.

VII. ADDITIONAL REQUIREMENTS.**# 025 [40 CFR Part 63 NESHAPS for Source Categories §40 CFR Subpart 63.10005]****SUBPART UUUUU - National Emission Standards for Hazardous Air Pollutants: Coal- and Oil-Fired Electric Utility Steam Generating Units****What are my initial compliance requirements and by what date must I conduct them?**

(a) General requirements. For each of your affected EGUs, you must demonstrate initial compliance with each applicable emissions limit in Table 1 or 2 of this subpart through performance testing. Where two emissions limits are specified for a particular pollutant (e.g., a heat input-based limit in lb/MMBtu and a gross output-based limit in lb/MWh), you may demonstrate compliance with either emission limit. For a particular compliance demonstration, you may be required to conduct one or more of the following activities in conjunction with performance testing: collection of data, e.g., hourly gross output data (megawatts); establishment of operating limits according to §63.10011 and Tables 4 and 7 to this subpart; and CMS performance evaluations. In all cases, you must demonstrate initial compliance no later than the date in paragraph (f) of this section for tune-up work practices for existing EGUs; the date that compliance must be demonstrated, as given in §63.9984 for other requirements for existing EGUs; and in paragraph (g) of this section for all requirements for new EGUs.

(1) To demonstrate initial compliance with an applicable emissions limit in Table 1 or 2 to this subpart using stack testing, the initial performance test generally consists of three runs at specified process operating conditions using approved methods. If you are required to establish operating limits (see paragraph (d) of this section and Table 4 to this subpart), you must collect all applicable parametric data during the performance test period. Also, if you choose to comply with an electrical output-based emission limit, you must collect hourly electrical load data during the test period.

(2) To demonstrate initial compliance using either a CMS that measures HAP concentrations directly (i.e., an Hg, HCl, or HF CEMS, or a sorbent trap monitoring system) or an SO₂ or PM CEMS, the initial performance test shall consist of 30- or, for certain coal-fired existing EGUs that use emissions averaging for Hg, 90-boiler operating days. If the CMS is certified prior to the compliance date (or, if applicable, the approved extended compliance date), the test shall begin with the first operating day on or after that date, except as otherwise provided in paragraph (b) of this section. If the CMS is not certified prior to the compliance date, the test shall begin with the first operating day after certification testing is successfully completed. In all cases, the initial 30- or 90- operating day averaging period must be completed on or before the date that compliance must be demonstrated (i.e., 180 days after the applicable compliance date).

(i) The CMS performance test must demonstrate compliance with the applicable Hg, HCl, HF, PM, or SO₂ emissions limit in Table 1 or 2 to this subpart.

(ii) You must collect hourly data from auxiliary monitoring systems (i.e., stack gas flow rate, CO₂, O₂, or moisture, as applicable) during the performance test period, in order to convert the pollutant concentrations to units of the standard. If you choose to comply with a gross output-based emission limit, you must also collect hourly gross output data during the performance test period.

(iii) For a group of affected units that are in the same subcategory, are subject to the same emission standards, and share a common stack, if you elect to demonstrate compliance by monitoring emissions at the common stack, startup and shutdown emissions (if any) that occur during the 30-(or, if applicable, 90-) boiler operating day performance test must either be excluded from or included in the compliance demonstration as follows:

(A) If one of the units that shares the stack either starts up or shuts down at a time when none of the other units is operating, you must exclude all pollutant emission rates measured during the startup or shutdown period, unless you are using a sorbent trap monitoring system to measure Hg emissions and have elected to include startup and shutdown emissions in the compliance demonstrations;

(B) If all units that are currently operating are in the startup or shutdown mode, you must exclude all pollutant emission rates measured during the startup or shutdown period, unless you are using a sorbent trap monitoring system to measure Hg emissions and have elected to include startup and shutdown emissions in the compliance demonstrations; or

**SECTION E. Source Group Restrictions.**

(C) If any unit starts up or shuts down at a time when another unit is operating, and the other unit is not in the startup or shutdown mode, you must include all pollutant emission rates measured during the startup or shutdown period in the compliance demonstrations.

(b) Performance testing requirements. If you choose to use performance testing to demonstrate initial compliance with the applicable emissions limits in Tables 1 and 2 to this subpart for your EGUs, you must conduct the tests according to §63.10007 and Table 5 to this subpart. For the purposes of the initial compliance demonstration, you may use test data and results from a performance test conducted prior to the date on which compliance is required as specified in §63.9984, provided that the following conditions are fully met:

- (1) For a performance test based on stack test data, the test was conducted no more than 12 calendar months prior to the date on which compliance is required as specified in §63.9984;
- (2) For a performance test based on data from a certified CEMS or sorbent trap monitoring system, the test consists of all valid CMS data recorded in the 30 boiler operating days immediately preceding that date;
- (3) The performance test was conducted in accordance with all applicable requirements in §63.10007 and Table 5 to this subpart;
- (4) A record of all parameters needed to convert pollutant concentrations to units of the emission standard (e.g., stack flow rate, diluent gas concentrations, hourly gross outputs) is available for the entire performance test period; and
- (5) For each performance test based on stack test data, you certify, and keep documentation demonstrating, that the EGU configuration, control devices, and fuel(s) have remained consistent with conditions since the prior performance test was conducted.
- (6) For performance stack test data that are collected prior to the date that compliance must be demonstrated and are used to demonstrate initial compliance with applicable emissions limits, the interval for subsequent stack tests begins on the date that compliance must be demonstrated.

(c)-(d) Not applicable.

(e) Tune-ups. All affected EGUs are subject to the work practice standards in Table 3 of this subpart. As part of your initial compliance demonstration, you must conduct a performance tune-up of your EGU according to §63.10021(e).

(f) For an existing EGU without a neural network, a tune-up, following the procedures in §63.10021(e), must occur within 6 months (180 days) after April 16, 2015. For an existing EGU with a neural network, a tune-up must occur within 18 months (545 days) after April 16, 2016. If a tune-up occurs prior to April 16, 2015, you must keep records showing that the tune-up met all rule requirements.

(g) Not applicable.

(h) Low emitting EGUs. The provisions of this paragraph (h) apply to pollutants with emissions limits from new EGUs except Hg and to all pollutants with emissions limits from existing EGUs. You may pursue this compliance option unless prohibited pursuant to §63.10000(c)(1)(i).

(1) An EGU may qualify for low emitting EGU (LEE) status for Hg, HCl, HF, filterable PM, total non-Hg HAP metals, or individual non-Hg HAP metals (or total HAP metals or individual HAP metals, for liquid oil-fired EGUs) if you collect performance test data that meet the requirements of this paragraph (h), and if those data demonstrate:

(i) For all pollutants except Hg, performance test emissions results less than 50 percent of the applicable emissions limits in Table 1 or 2 to this subpart for all required testing for 3 consecutive years; or

(ii) For Hg emissions from an existing EGU, either:

(A) Average emissions less than 10 percent of the applicable Hg emissions limit in Table 2 to this subpart (expressed either in units of lb/TBtu or lb/GWh); or

SECTION E. Source Group Restrictions.

(B) Potential Hg mass emissions of 29.0 or fewer pounds per year and compliance with the applicable Hg emission limit in Table 2 to this subpart (expressed either in units of lb/TBtu or lb/GWh).

(2) For all pollutants except Hg, you must conduct all required performance tests described in §63.10007 to demonstrate that a unit qualifies for LEE status.

(i) When conducting emissions testing to demonstrate LEE status, you must increase the minimum sample volume specified in Table 1 or 2 nominally by a factor of two.

(ii) Follow the instructions in §63.10007(e) and Table 5 to this subpart to convert the test data to the units of the applicable standard.

(3)-(5) Not applicable.

(i) Not applicable.

(j) Startup and shutdown for coal-fired or solid oil derived-fired units. You must follow the requirements given in Table 3 to this subpart.

(k) You must submit a Notification of Compliance Status summarizing the results of your initial compliance demonstration, as provided in §63.10030.

026 [40 CFR Part 63 NESHAPS for Source Categories §40 CFR Subpart 63.10011]

SUBPART UUUUU - National Emission Standards for Hazardous Air Pollutants: Coal- and Oil-Fired Electric Utility Steam Generating Units

How do I demonstrate initial compliance with the emissions limits and work practice standards?

(a) You must demonstrate initial compliance with each emissions limit that applies to you by conducting performance testing.

(b) Not applicable.

(c)(1) If you use CEMS or sorbent trap monitoring systems to measure a HAP (e.g., Hg or HCl) directly, the initial performance test, shall consist of a 30-boiler operating day (or, for certain coal-fired, existing EGUs that use emissions averaging for Hg, a 90-boiler operating day) rolling average emissions rate obtained with a certified CEMS or sorbent trap system, expressed in units of the standard. If the monitoring system is certified prior to the applicable compliance date, the initial averaging period shall either begin with: The first boiler operating day on or after the compliance date; or 30 (or, if applicable, 90) boiler operating days prior to that date, as described in §63.10005(b). In all cases, the initial 30- or 90-boiler operating day averaging period must be completed on or before the date that compliance must be demonstrated, in accordance with §63.9984(f). Initial compliance is demonstrated if the results of the performance test meet the applicable emission limit in Table 1 or 2 to this subpart.

(2) Not applicable.

(d) For candidate LEE units, use the results of the performance testing described in §63.10005(h) to determine initial compliance with the applicable emission limit(s) in Table 1 or 2 to this subpart and to determine whether the unit qualifies for LEE status.

(e) You must submit a Notification of Compliance Status containing the results of the initial compliance demonstration, in accordance with §63.10030(e).

(f)(1) You must determine the fuel whose combustion produces the least uncontrolled emissions, i.e., the cleanest fuel, either natural gas or distillate oil, that is available on site or accessible nearby for use during periods of startup or shutdown.

(2) Your cleanest fuel, either natural gas or distillate oil, for use during periods of startup or shutdown determination may take safety considerations into account.

**SECTION E. Source Group Restrictions.**

(g) You must follow the startup or shutdown requirements as established in Table 3 to this subpart for each coal-fired, liquid oil-fired, or solid oil-derived fuel-fired EGU.

(1) You may use the diluent cap and default gross output values, as described in §63.10007(f), during startup periods or shutdown periods.

(2) You must operate all CMS, collect data, calculate pollutant emission rates, and record data during startup periods or shutdown periods.

(3) You must report the information as required in §63.10031.

(4) Not applicable.

027 [40 CFR Part 63 NESHAPS for Source Categories §40 CFR Subpart 63.10021]**SUBPART UUUUU - National Emission Standards for Hazardous Air Pollutants: Coal- and Oil-Fired Electric Utility Steam Generating Units****How do I demonstrate continuous compliance with the emission limitations, operating limits, and work practice standards?**

(a) You must demonstrate continuous compliance with each emissions limit, operating limit, and work practice standard in Tables 1 through 4 to this subpart that applies to you, according to the monitoring specified in Tables 6 and 7 to this subpart and paragraphs (b) through (g) of this section.

(b) Except as otherwise provided in §63.10020(c), if you use a CEMS to measure SO₂, PM, HCl, HF, or Hg emissions, or using a sorbent trap monitoring system to measure Hg emissions, you must demonstrate continuous compliance by using all quality-assured hourly data recorded by the CEMS (or sorbent trap monitoring system) and the other required monitoring systems (e.g., flow rate, CO₂, O₂, or moisture systems) to calculate the arithmetic average emissions rate in units of the standard on a continuous 30-boiler operating day (or, if alternate emissions averaging is used for Hg, 90-boiler operating day) rolling average basis, updated at the end of each new boiler operating day. Use Equation 8 to determine the 30- (or, if applicable, 90-) boiler operating day rolling average.

[Please refer to §63.10021 under Title 40 - Protection of Environmental in www.ecfr.gov for Equation 8.]

(c) Not applicable.

(d) If you use quarterly performance testing to demonstrate compliance with one or more applicable emissions limits in Table 1 or 2 to this subpart, you

(1) May skip performance testing in those quarters during which less than 168 boiler operating hours occur, except that a performance test must be conducted at least once every calendar year.

(2) Must conduct the performance test as defined in Table 5 to this subpart and calculate the results of the testing in units of the applicable emissions standard; and

(3) Not applicable.

(e) [See VI. Work Practice Requirements for this source group.]

(f)-(g) [See V. Reporting Requirements for this source group.]

(h) [See VI. Work Practice Requirements for this source group.]

(i) [See V. Reporting Requirements for this source group.]

028 [40 CFR Part 63 NESHAPS for Source Categories §40 CFR Subpart 63.10040]**SUBPART UUUUU - National Emission Standards for Hazardous Air Pollutants: Coal- and Oil-Fired Electric Utility Steam Generating Units****What parts of the General Provisions apply to me?**

Table 9 to this subpart shows which parts of the General Provisions in § 63.1 through 63.15 apply to you.

**SECTION E. Source Group Restrictions.****# 029 [40 CFR Part 63 NESHAPS for Source Categories §40 CFR Subpart 63.10041]****SUBPART UUUUU - National Emission Standards for Hazardous Air Pollutants: Coal- and Oil-Fired Electric Utility Steam Generating Units****Who implements and enforces this subpart?**

(a) This subpart can be implemented and enforced by U.S. EPA, or a delegated authority such as your state, local, or tribal agency. If the EPA Administrator has delegated authority to your state, local, or tribal agency, then that agency (as well as the U.S. EPA) has the authority to implement and enforce this subpart. You should contact your EPA Regional Office to find out if this subpart is delegated to your state, local, or tribal agency.

(b) In delegating implementation and enforcement authority of this subpart to a state, local, or tribal agency under 40 CFR part 63, subpart E, the authorities listed in paragraphs (b)(1) through (4) of this section are retained by the EPA Administrator and are not transferred to the state, local, or tribal agency; moreover, the U.S. EPA retains oversight of this subpart and can take enforcement actions, as appropriate, with respect to any failure by any person to comply with any provision of this subpart.

(1) Approval of alternatives to the non-opacity emission limits and work practice standards in §63.9991(a) and (b) under §63.6(g).

(2) Approval of major change to test methods in Table 5 to this subpart under §63.7(e)(2)(ii) and (f) and as defined in §63.90, approval of minor and intermediate changes to monitoring performance specifications/procedures in Table 5 where the monitoring serves as the performance test method (see definition of "test method" in §63.2.

(3) Approval of major changes to monitoring under §63.8(f) and as defined in §63.90.

(4) Approval of major change to recordkeeping and reporting under §63.10(e) and as defined in §63.90.

030 [40 CFR Part 63 NESHAPS for Source Categories §40 CFR Subpart 63.10042]**SUBPART UUUUU - National Emission Standards for Hazardous Air Pollutants: Coal- and Oil-Fired Electric Utility Steam Generating Units****What definitions apply to this subpart?**

Terms used in this subpart are defined in the Clean Air Act (CAA), in §63.2 (the General Provisions), and in this section §63.10042.

031 [40 CFR Part 63 NESHAPS for Source Categories §40 CFR Subpart 63.9980]**SUBPART UUUUU - National Emission Standards for Hazardous Air Pollutants: Coal- and Oil-Fired Electric Utility Steam Generating Units****What is the purpose of this subpart?**

This subpart establishes national emission limitations and work practice standards for hazardous air pollutants (HAP) emitted from coal- and oil-fired electric utility steam generating units (EGUs) as defined in §63.10042 of this subpart. This subpart also establishes requirements to demonstrate initial and continuous compliance with the emission limitations.

032 [40 CFR Part 63 NESHAPS for Source Categories §40 CFR Subpart 63.9981]**SUBPART UUUUU - National Emission Standards for Hazardous Air Pollutants: Coal- and Oil-Fired Electric Utility Steam Generating Units****Am I subject to this subpart?**

You are subject to this subpart if you own or operate a coal-fired EGU or an oil-fired EGU as defined in §63.10042 of this subpart.

033 [40 CFR Part 63 NESHAPS for Source Categories §40 CFR Subpart 63.9982]**SUBPART UUUUU - National Emission Standards for Hazardous Air Pollutants: Coal- and Oil-Fired Electric Utility Steam Generating Units****What is the affected source of this subpart?**

(a) This subpart applies to each individual or group of two or more new, reconstructed, or existing affected source(s) as described in paragraphs (a)(1) and (2) of this section within a contiguous area and under common control.

(1) The affected source of this subpart is the collection of all existing coal- or oil-fired EGUs, as defined in §63.10042, within a subcategory.

**SECTION E. Source Group Restrictions.**

(2) Not applicable.

(b)-(c) Not applicable.

(d) An EGU is existing if it is not new or reconstructed. An existing electric steam generating unit that meets the applicability requirements after the effective date of this final rule due to a change in process (e.g., fuel or utilization) is considered to be an existing source under this subpart.

034 [40 CFR Part 63 NESHAPS for Source Categories §40 CFR Subpart 63.9984]

SUBPART UUUUU - National Emission Standards for Hazardous Air Pollutants: Coal- and Oil-Fired Electric Utility Steam Generating Units

When do I have to comply with this subpart?

(a) Not applicable.

(b) If you have an existing EGU, you must comply with this subpart no later than April 16, 2015.

(c) You must meet the notification requirements in §63.10030 according to the schedule in §63.10030 and in subpart A of this part. Some of the notifications must be submitted before you are required to comply with the emission limits and work practice standards in this subpart.

(d)-(e) Not applicable.

(f) You must demonstrate that compliance has been achieved, by conducting the required performance tests and other activities, no later than 180 days after the applicable date in paragraph (a), (b), (c), (d), or (e) of this section.

035 [40 CFR Part 63 NESHAPS for Source Categories §40 CFR subpart 63.10000]

SUBPART UUUUU - National Emission Standards for Hazardous Air Pollutants: Coal- and Oil-Fired Electric Utility Steam Generating Units

What are my general requirements for complying with this subpart?

(a) You must be in compliance with the emission limits and operating limits in this subpart. These limits apply to you at all times except during periods of startup and shutdown; however, for coal-fired, liquid oil-fired, or solid oil-derived fuel-fired EGUs, you are required to meet the work practice requirements, items 3 and 4, in Table 3 to this subpart during periods of startup or shutdown.

(b) At all times you must operate and maintain any affected source, including associated air pollution control equipment and monitoring equipment, in a manner consistent with safety and good air pollution control practices for minimizing emissions. Determination of whether such operation and maintenance procedures are being used will be based on information available to the EPA Administrator which may include, but is not limited to, monitoring results, review of operation and maintenance procedures, review of operation and maintenance records, and inspection of the source.

(c)(1) For coal-fired units, IGCC units, and solid oil-derived fuel-fired units, initial performance testing is required for all pollutants, to demonstrate compliance with the applicable emission limits.

(i) For a coal-fired or solid oil-derived fuel-fired EGU or IGCC EGU, you may conduct initial performance testing in accordance with §63.10005(h), to determine whether the EGU qualifies as a low emitting EGU (LEE) for one or more applicable emission limits, except as otherwise provided in paragraphs (c)(1)(i)(A) and (B) of this section:

(A)-(C) Not applicable.

(ii) For a qualifying LEE for Hg emissions limits, you must conduct a 30-day performance test using Method 30B at least once every 12 calendar months to demonstrate continued LEE status.

(iii) For a qualifying LEE of any other applicable emissions limits, you must conduct a performance test at least once every 36 calendar months to demonstrate continued LEE status.

(iv) If your coal-fired or solid oil derived fuel-fired EGU or IGCC EGU does not qualify as a LEE for total non-mercury HAP metals, individual non-mercury HAP metals, or filterable particulate matter (PM), you must demonstrate compliance through an initial performance test and you must monitor continuous performance through either use of a particulate matter

**SECTION E. Source Group Restrictions.**

continuous parametric monitoring system (PM CPMS), a PM CEMS, or, for an existing EGU, compliance performance testing repeated quarterly.

(v) If your coal-fired or solid oil-derived fuel-fired EGU does not qualify as a LEE for hydrogen chloride (HCl), you may demonstrate initial and continuous compliance through use of an HCl CEMS, installed and operated in accordance with Appendix B to this subpart. As an alternative to HCl CEMS, you may demonstrate initial and continuous compliance by conducting an initial and periodic quarterly performance stack test for HCl. If your EGU uses wet or dry flue gas desulfurization technology (this includes limestone injection into a fluidized bed combustion unit), you may apply a second alternative to HCl CEMS by installing and operating a sulfur dioxide (SO₂) CEMS installed and operated in accordance with part 75 of this chapter to demonstrate compliance with the applicable SO₂ emissions limit.

(vi) If your coal-fired or solid oil-derived fuel-fired EGU does not qualify as a LEE for Hg, you must demonstrate initial and continuous compliance through use of a Hg CEMS or a sorbent trap monitoring system, in accordance with appendix A to this subpart.

(A) You may choose to use separate sorbent trap monitoring systems to comply with this subpart: One sorbent trap monitoring system to demonstrate compliance with the numeric mercury emissions limit during periods other than startup or shutdown and the other sorbent trap monitoring system to report average mercury concentration during startup periods or shutdown periods.

(B) You may choose to use one sorbent trap monitoring system to demonstrate compliance with the mercury emissions limit at all times (including startup periods and shutdown periods) and to report average mercury concentration. You must follow the startup or shutdown requirements that follow and as given in Table 3 to this subpart for each coal-fired, liquid oil-fired, or solid oil-derived fuel-fired EGU.

(2) For liquid oil-fired EGUs-Not applicable.

(d)(1) If you demonstrate compliance with any applicable emissions limit through use of a continuous monitoring system (CMS), where a CMS includes a continuous parameter monitoring system (CPMS) as well as a continuous emissions monitoring system (CEMS), you must develop a site-specific monitoring plan and submit this site-specific monitoring plan, if requested, at least 60 days before your initial performance evaluation (where applicable) of your CMS. This requirement also applies to you if you petition the Administrator for alternative monitoring parameters under §63.8(f). This requirement to develop and submit a site-specific monitoring plan does not apply to affected sources with existing monitoring plans that apply to CEMS and CPMS prepared under appendix B to part 60 or part 75 of this chapter, and that meet the requirements of §63.10010. Using the process described in §63.8(f)(4), you may request approval of monitoring system quality assurance and quality control procedures alternative to those specified in this paragraph of this section and, if approved, include those in your site-specific monitoring plan. The monitoring plan must address the provisions in paragraphs (d)(2) through (5) of this section.

(2) The site-specific monitoring plan shall include the information specified in paragraphs (d)(5)(i) through (d)(5)(vii) of this section. Alternatively, the requirements of paragraphs (d)(5)(i) through (d)(5)(vii) are considered to be met for a particular CMS or sorbent trap monitoring system if:

(i) The CMS or sorbent trap monitoring system is installed, certified, maintained, operated, and quality-assured either according to part 75 of this chapter, or appendix A or B to this subpart; and

(ii) The recordkeeping and reporting requirements of part 75 of this chapter, or appendix A or B to this subpart, that pertain to the CMS are met.

(3) If requested by the Administrator, you must submit the monitoring plan (or relevant portion of the plan) at least 60 days before the initial performance evaluation of a particular CMS, except where the CMS has already undergone a performance evaluation that meets the requirements of §63.10010 (e.g., if the CMS was previously certified under another program).

(4) You must operate and maintain the CMS according to the site-specific monitoring plan.

(5) The provisions of the site-specific monitoring plan must address the following items:

**SECTION E. Source Group Restrictions.**

- (i) Installation of the CMS or sorbent trap monitoring system sampling probe or other interface at a measurement location relative to each affected process unit such that the measurement is representative of control of the exhaust emissions (e.g., on or downstream of the last control device). See §63.10010(a) for further details. For PM CPMS installations, follow the procedures in §63.10010(h).
- (ii) Performance and equipment specifications for the sample interface, the pollutant concentration or parametric signal analyzer, and the data collection and reduction systems.
- (iii) Schedule for conducting initial and periodic performance evaluations.
- (iv) Performance evaluation procedures and acceptance criteria (e.g., calibrations), including the quality control program in accordance with the general requirements of §63.8(d).
- (v) On-going operation and maintenance procedures, in accordance with the general requirements of §§63.8(c)(1)(ii), (c)(3), and (c)(4)(ii).
- (vi) Conditions that define a CMS that is out of control consistent with §63.8(c)(7)(i) and for responding to out of control periods consistent with §§63.8(c)(7)(ii) and (c)(8).
- (vii) On-going recordkeeping and reporting procedures, in accordance with the general requirements of §§63.10(c), (e)(1), and (e)(2)(i), or as specifically required under this subpart.
- (e) As part of your demonstration of continuous compliance, you must perform periodic tune-ups of your EGU(s), according to §63.10021(e).
- (f) Except as provided under paragraph (n) of this section, you are subject to the requirements of this subpart for at least 6 months following the last date you met the definition of an EGU subject to this subpart (e.g., 6 months after a cogeneration unit provided more than one third of its potential electrical output capacity and more than 25 megawatts electrical output to any power distributions system for sale). You may opt to remain subject to the provisions of this subpart beyond 6 months after the last date you met the definition of an EGU subject to this subpart, unless your unit is a solid waste incineration unit subject to standards under CAA section 129 (e.g., 40 CFR part 60, subpart CCCC (New Source Performance Standards (NSPS) for Commercial and Industrial Solid Waste Incineration Units, or subpart DDDD (Emissions Guidelines (EG) for Existing Commercial and Industrial Solid Waste Incineration Units). Notwithstanding the provisions of this subpart, an EGU that starts combusting solid waste is immediately subject to standards under CAA section 129 and the EGU remains subject to those standards until the EGU no longer meets the definition of a solid waste incineration unit consistent with the provisions of the applicable CAA section 129 standards.
- (g) Except as provided under paragraph (n) of this section, if your unit no longer meets the definition of an EGU subject to this subpart you must be in compliance with any newly applicable standards on the date you are no longer subject to this subpart. The date you are no longer subject to this subpart is a date selected by you, that must be at least 6 months from the date that your unit last met the definition of an EGU subject to this subpart or the date you begin combusting solid waste, consistent with §63.9983(d). Your source must remain in compliance with this subpart until the date you select to cease complying with this subpart or the date you begin combusting solid waste, whichever is earlier.

(h)-(n) Not applicable.

036 [40 CFR Part 63 NESHAPS for Source Categories §40 CFR subpart 63.9990]

SUBPART UUUUU - National Emission Standards for Hazardous Air Pollutants: Coal- and Oil-Fired Electric Utility Steam Generating Units

What are the subcategories of EGUs?

(a) Coal-fired EGUs are subcategorized as defined in paragraphs (a)(1) through (a)(2) of this section and as defined in §63.10042.

(1) EGUs designed for coal with a heating value greater than or equal to 8,300 Btu/lb, and

(2) Not applicable.

**SECTION E. Source Group Restrictions.**

(b)-(c) Not applicable.

**# 037 [40 CFR Part 63 NESHAPS for Source Categories §Appendix A to Subpart UUUUU of Part 63]
SUBPART UUUUU - National Emission Standards for Hazardous Air Pollutants: Coal- and Oil-Fired Electric Utility Steam
Generating Units
Hg Monitoring Provisions**

Please reference 40 CFR Part 63 Subpart UUUUU Appendix A.

**# 038 [40 CFR Part 63 NESHAPS for Source Categories §Table 7 to Subpart UUUUU]
SUBPART UUUUU - National Emission Standards for Hazardous Air Pollutants: Coal- and Oil-Fired Electric Utility Steam
Generating Units
Demonstrating Continuous Compliance**

As stated in §63.10021, you must show continuous compliance with the emission limitations for affected sources according to the following:

If you use one of the following to meet applicable emissions limits, operating limits, or work practice standards you must demonstrate continuous compliance by:

(1) CEMS to measure filterable PM, SO₂, HCl, HF, or Hg emissions, or using a sorbent trap monitoring system to measure Hg by calculating the 30- (or 90-) boiler operating day rolling arithmetic average emissions rate in units of the applicable emissions standard basis at the end of each boiler operating day using all of the quality assured hourly average CEMS or sorbent trap data for the previous 30- (or 90-) boiler operating days, excluding data recorded during periods of startup or shutdown.

(2)-(3) Not applicable.

(4) Quarterly performance testing for coal-fired, solid oil derived fired, or liquid oil-fired EGUs to measure compliance with one or more non-PM (or its alternative emission limits) applicable emissions limit in Table 1 or 2, or PM (or its alternative emission limits) applicable emissions limit in Table 2 by calculating the results of the testing in units of the applicable emissions standard.

(5) Conducting periodic performance tune-ups of your EGU(s) by conducting periodic performance tune-ups of your EGU(s), as specified in §63.10021(e).

(6) Work practice standards for coal-fired, liquid oil-fired, or solid oil-derived fuel-fired EGUs during startup by operating in accordance with Table 3.

(7) Work practice standards for coal-fired, liquid oil-fired, or solid oil-derived fuel-fired EGUs during shutdown by operating in accordance with Table 3.

**# 039 [40 CFR Part 63 NESHAPS for Source Categories §Table 9 to Subpart UUUUU]
SUBPART UUUUU - National Emission Standards for Hazardous Air Pollutants: Coal- and Oil-Fired Electric Utility Steam
Generating Units
Applicability of General Provisions to Subpart UUUUU**

As stated in §63.10040, you must comply with the applicable General Provisions according to the following:

§63.1 -Applicability: Applies to subpart UUUUU

§63.2 -Definitions: Applies to subpart UUUUU [Additional terms defined in §63.10042.]

§63.3 -Units and Abbreviations: Applies to subpart UUUUU

§63.4 -Prohibited Activities and Circumvention:Applies to subpart UUUUU

§63.5 -Preconstruction Review and Notification Requirements: Applies to subpart UUUUU

§63.6(a), (b)(1) through (5), (b)(7), (c), (f)(2) and (3), (h)(2) through (9), (i), (j) Compliance with Standards and Maintenance Requirements: Applies to subpart UUUUU

§63.6(e)(1)(i) General Duty to minimize emissions:Does Not Apply to subpart UUUUU [See §63.10000(b) for general duty requirement.]

§63.6(e)(1)(ii) Requirement to correct malfunctions ASAP: Does not apply to subpart UUUUU

§63.6(e)(3) SSM Plan requirements: Does not apply to subpart UUUUU

**SECTION E. Source Group Restrictions.**

§63.6(f)(1) SSM exemption: Does not apply to subpart UUUUU

§63.6(h)(1) SSM exemption: Does not apply to subpart UUUUU

§63.6(g) Compliance with Standards and Maintenance Requirements, Use of an alternative non-opacity emission standard: Applies to subpart UUUUU [See §§63.10011(g)(4) and 63.10021(h)(4) for additional requirements.]

§63.7(e)(1) Performance testing: Does not apply to subpart UUUUU [See §63.10007.]

§63.8 -Monitoring Requirements: Applies to subpart UUUUU

§63.8(c)(1)(i) General duty to minimize emissions and CMS operation: Does not apply to subpart UUUUU [See §63.10000(b) for general duty requirement.]

§63.8(c)(1)(iii) Requirement to develop SSM Plan for CMS: Does not apply to subpart UUUUU

§63.8(d)(3) Written procedures for CMS: Applies to subpart UUUUU, [except for last sentence, which refers to an SSM plan. SSM plans are not required.]

§63.9 -Notification Requirements: Applies to subpart UUUUU, [except (1) for the 60-day notification prior to conducting a performance test in §63.9(e); instead use a 30-day notification period per §63.10030(d), (2) the notification of the CMS performance evaluation in §63.9(g)(1) is limited to RATAs, and (3) the information required per §63.9(h)(2)(i); instead provide the information required per §63.10030(e)(1) through (e)(6) and (e)(8).]

§63.10(a), (b)(1), (c), (d)(1) and (2), (e), and (f) Recordkeeping and Reporting Requirements: Applies to subpart UUUUU, [except for the requirements to submit written reports under §63.10(e)(3)(v).]

§63.10(b)(2)(i) Recordkeeping of occurrence and duration of startups and shutdowns: Does not apply to subpart UUUUU

§63.10(b)(2)(ii) Recordkeeping of malfunctions: Does not apply to subpart UUUUU [See §63.10001 for recordkeeping of (1) occurrence and duration and (2) actions taken during malfunction.]

§63.10(b)(2)(iii) Maintenance records: Applies to subpart UUUUU

§63.10(b)(2)(iv) Actions taken to minimize emissions during SSM: Does not apply to subpart UUUUU

§63.10(b)(2)(v) Actions taken to minimize emissions during SSM: Does not apply to subpart UUUUU

§63.10(b)(2)(vi) Recordkeeping for CMS malfunctions: Applies to subpart UUUUU

§63.10(b)(2)(vii) through (ix) Other CMS requirements: Applies to subpart UUUUU

§63.10(b)(3) and (d)(3) through (5): Does not apply to subpart UUUUU

§63.10(c)(7) Additional recordkeeping requirements for CMS—identifying exceedances and excess emissions: Applies to subpart UUUUU

§63.10(c)(8) Additional recordkeeping requirements for CMS—identifying exceedances and excess emissions: Applies to subpart UUUUU

§63.10(c)(10) Recording nature and cause of malfunction: Does not apply to subpart UUUUU [See §63.10032(g) and (h) for malfunctions recordkeeping requirements.]

§63.10(c)(11) Recording corrective actions: Does not apply to subpart UUUUU [See §63.10032(g) and (h) for malfunctions recordkeeping requirements.]

§63.10(c)(15) Use of SSM Plan: Does not apply to subpart UUUUU

§63.10(d)(5) SSM reports: Does not apply to subpart UUUUU [See §63.10021(h) and (i) for malfunction reporting requirements.]

§63.11 -Control Device Requirements: Does not apply to subpart UUUUU

§63.12 -State Authority and Delegation: Applies to subpart UUUUU

§§63.13 through 63.16 -Addresses, Incorporation by Reference, Availability of Information, Performance Track Provisions: Applies to subpart UUUUU

§§63.1(a)(5),(a)(7) through (9), (b)(2), (c)(3) and (4), (d), 63.6(b)(6), (c)(3) and (4), (d), (e)(2), (e)(3)(ii), (h)(3), (h)(5)(iv), 63.8(a)(3), 63.9(b)(3), (h)(4), 63.10(c)(2) through (4), (c)(9). [Reserved]: Does not apply to subpart UUUUU

*** **Permit Shield in Effect.** ***

**SECTION E. Source Group Restrictions.**

Group Name: G08

Group Description: 40 CFR Part 60 Subpart IIII

Sources included in this group

ID	Name
113	EMERGENCY QUENCH PUMPS/ENGINES (2-130HP & 2,328-BHP)
114	EMERGENCY DIESEL GENERATOR (1,474-BHP ENG., 1,000-KW OUTPUT)

I. RESTRICTIONS.**Emission Restriction(s).****# 001 [40 CFR Part 60 Standards of Performance for New Stationary Sources §40 CFR 60.4202]****Subpart IIII - Standards of Performance for Stationary Compression Ignition Internal Combustion Engines****What emission standards must I meet for emergency engines if I am a stationary CI internal combustion engine manufa**

(a) Stationary CI internal combustion engine manufacturers must certify their 2007 model year and later emergency stationary CI ICE with a maximum engine power less than or equal to 2,237 KW (3,000 HP) and a displacement of less than 10 liters per cylinder that are not fire pump engines to the emission standards specified in paragraphs (a)(1) through (2) of this section.

(1) Not applicable.

(2) For engines with a maximum engine power greater than or equal to 37 KW (50 HP), the certification emission standards for new nonroad CI engines for the same model year and maximum engine power in 40 CFR 89.112 and 40 CFR 89.113 for all pollutants beginning in model year 2007.

(b)-(h) Not applicable.

002 [40 CFR Part 60 Standards of Performance for New Stationary Sources §40 CFR 60.4207]**Subpart IIII - Standards of Performance for Stationary Compression Ignition Internal Combustion Engines****What fuel requirements must I meet if I am an owner or operator of a stationary CI internal combustion engine subject to**

(a) Not applicable.

(b) Beginning October 1, 2010, owners and operators of stationary CI ICE subject to this subpart with a displacement of less than 30 liters per cylinder that use diesel fuel must use diesel fuel that meets the requirements of 40 CFR 80.510(b) for nonroad diesel fuel, except that any existing diesel fuel purchased (or otherwise obtained) prior to October 1, 2010, may be used until depleted.

(c) [Reserved]

(d)-(e) Not applicable.

Title 40: Protection of Environment

PART 80—REGULATION OF FUELS AND FUEL ADDITIVES

Subpart I—Motor Vehicle Diesel Fuel; Nonroad, Locomotive, and Marine Diesel Fuel; and ECA Marine Fuel

§80.510 What are the standards and marker requirements for refiners and importers for NRLM diesel fuel and ECA marine fuel?

(a) Not applicable.

(b) Beginning June 1, 2010. Except as otherwise specifically provided in this subpart, all NR and LM diesel fuel is subject to the following per-gallon standards:

(1) Sulfur content.

(i) 15 ppm maximum for NR diesel fuel.

(ii) Not applicable.

**SECTION E. Source Group Restrictions.**

(2) Cetane index or aromatic content, as follows:

(i) A minimum cetane index of 40; or

(ii) A maximum aromatic content of 35 volume percent.

(c)-(k) Not applicable.

II. TESTING REQUIREMENTS.

No additional testing requirements exist except as provided in other sections of this permit including Section B (Title V General Requirements).

III. MONITORING REQUIREMENTS.

No additional monitoring requirements exist except as provided in other sections of this permit including Section B (Title V General Requirements).

IV. RECORDKEEPING REQUIREMENTS.

No additional record keeping requirements exist except as provided in other sections of this permit including Section B (Title V General Requirements).

V. REPORTING REQUIREMENTS.

No additional reporting requirements exist except as provided in other sections of this permit including Section B (Title V General Requirements).

VI. WORK PRACTICE REQUIREMENTS.

**# 003 [40 CFR Part 60 Standards of Performance for New Stationary Sources §40 CFR 60.4206]
Subpart III - Standards of Performance for Stationary Compression Ignition Internal Combustion Engines
How long must I meet the emission standards if I am an owner or operator of a stationary CI internal combustion engine?**

Owners and operators of stationary CI ICE must operate and maintain stationary CI ICE that achieve the emission standards as required in §§60.4204 and 60.4205 over the entire life of the engine.

VII. ADDITIONAL REQUIREMENTS.

**# 004 [40 CFR Part 60 Standards of Performance for New Stationary Sources §40 CFR 60.4200]
Subpart III - Standards of Performance for Stationary Compression Ignition Internal Combustion Engines
Am I subject to this subpart?**

(a) The provisions of this subpart are applicable to manufacturers, owners, and operators of stationary compression ignition (CI) internal combustion engines (ICE) and other persons as specified in paragraphs (a)(1) through (4) of this section. For the purposes of this subpart, the date that construction commences is the date the engine is ordered by the owner or operator.

(1) Not applicable.

(2) Owners and operators of stationary CI ICE that commence construction after July 11, 2005, where the stationary CI ICE are:

(i) Manufactured after April 1, 2006, and are not fire pump engines, or

(ii) Manufactured as a certified National Fire Protection Association (NFPA) fire pump engine after July 1, 2006.

(3) Not applicable.

(4) The provisions of §60.4208 of this subpart are applicable to all owners and operators of stationary CI ICE that

**SECTION E. Source Group Restrictions.**

commence construction after July 11, 2005.

(b) Not applicable.

(c)-(e) Not applicable.

005 [40 CFR Part 60 Standards of Performance for New Stationary Sources §40 CFR 60.4205]

Subpart III - Standards of Performance for Stationary Compression Ignition Internal Combustion Engines

What emission standards must I meet for emergency engines if I am an owner or operator of a stationary CI internal combustion engine?

(a) Not applicable.

(b) Owners and operators of 2007 model year and later emergency stationary CI ICE with a displacement of less than 30 liters per cylinder that are not fire pump engines must comply with the emission standards for new nonroad CI engines in §60.4202, for all pollutants, for the same model year and maximum engine power for their 2007 model year and later emergency stationary CI ICE.

(c)-(f) Not applicable.

006 [40 CFR Part 60 Standards of Performance for New Stationary Sources §40 CFR 60.4209]

Subpart III - Standards of Performance for Stationary Compression Ignition Internal Combustion Engines

What are the monitoring requirements if I am an owner or operator of a stationary CI internal combustion engine?

If you are an owner or operator, you must meet the monitoring requirements of this section. In addition, you must also meet the monitoring requirements specified in §60.4211.

(a) If you are an owner or operator of an emergency stationary CI internal combustion engine that does not meet the standards applicable to non-emergency engines, you must install a non-resettable hour meter prior to startup of the engine.

(b) Not applicable.

007 [40 CFR Part 60 Standards of Performance for New Stationary Sources §40 CFR 60.4211]

Subpart III - Standards of Performance for Stationary Compression Ignition Internal Combustion Engines

What are my compliance requirements if I am an owner or operator of a stationary CI internal combustion engine?

(a) If you are an owner or operator and must comply with the emission standards specified in this subpart, you must do all of the following, except as permitted under paragraph (g) of this section:

(1) Operate and maintain the stationary CI internal combustion engine and control device according to the manufacturer's emission-related written instructions;

(2) Change only those emission-related settings that are permitted by the manufacturer; and

(3) Meet the requirements of 40 CFR parts 89, 94 and/or 1068, as they apply to you.

(b) Not applicable.

(c) If you are an owner or operator of a 2007 model year and later stationary CI internal combustion engine and must comply with the emission standards specified in §60.4204(b) or §60.4205(b), or if you are an owner or operator of a CI fire pump engine that is manufactured during or after the model year that applies to your fire pump engine power rating in table 3 to this subpart and must comply with the emission standards specified in §60.4205(c), you must comply by purchasing an engine certified to the emission standards in §60.4204(b), or §60.4205(b) or (c), as applicable, for the same model year and maximum (or in the case of fire pumps, NFPA nameplate) engine power. The engine must be installed and configured according to the manufacturer's emission-related specifications, except as permitted in paragraph (g) of this section.

(d)-(e) Not applicable.

(f) If you own or operate an emergency stationary ICE, you must operate the emergency stationary ICE according to the requirements in paragraphs (f)(1) through (3) of this section. In order for the engine to be considered an emergency

**SECTION E. Source Group Restrictions.**

stationary ICE under this subpart, any operation other than emergency operation, maintenance and testing, emergency demand response, and operation in non-emergency situations for 50 hours per year, as described in paragraphs (f)(1) through (3) of this section, is prohibited. If you do not operate the engine according to the requirements in paragraphs (f)(1) through (3) of this section, the engine will not be considered an emergency engine under this subpart and must meet all requirements for non-emergency engines.

(1) There is no time limit on the use of emergency stationary ICE in emergency situations.

(2) You may operate your emergency stationary ICE for any combination of the purposes specified in paragraphs (f)(2)(i) through (iii) of this section for a maximum of 100 hours per calendar year. Any operation for non-emergency situations as allowed by paragraph (f)(3) of this section counts as part of the 100 hours per calendar year allowed by this paragraph (f)(2).

(i) Emergency stationary ICE may be operated for maintenance checks and readiness testing, provided that the tests are recommended by federal, state or local government, the manufacturer, the vendor, the regional transmission organization or equivalent balancing authority and transmission operator, or the insurance company associated with the engine. The owner or operator may petition the Administrator for approval of additional hours to be used for maintenance checks and readiness testing, but a petition is not required if the owner or operator maintains records indicating that federal, state, or local standards require maintenance and testing of emergency ICE beyond 100 hours per calendar year.

(ii)-(iii) VACATED.

(3) Emergency stationary ICE may be operated for up to 50 hours per calendar year in non-emergency situations. The 50 hours of operation in non-emergency situations are counted as part of the 100 hours per calendar year for maintenance and testing and emergency demand response provided in paragraph (f)(2) of this section. Except as provided in paragraph (f)(3)(i) of this section, the 50 hours per calendar year for non-emergency situations cannot be used for peak shaving or non-emergency demand response, or to generate income for a facility to an electric grid or otherwise supply power as part of a financial arrangement with another entity.

(i) The 50 hours per year for non-emergency situations can be used to supply power as part of a financial arrangement with another entity if all of the following conditions are met:

(A) The engine is dispatched by the local balancing authority or local transmission and distribution system operator;

(B) The dispatch is intended to mitigate local transmission and/or distribution limitations so as to avert potential voltage collapse or line overloads that could lead to the interruption of power supply in a local area or region.

(C) The dispatch follows reliability, emergency operation or similar protocols that follow specific NERC, regional, state, public utility commission or local standards or guidelines.

(D) The power is provided only to the facility itself or to support the local transmission and distribution system.

(E) The owner or operator identifies and records the entity that dispatches the engine and the specific NERC, regional, state, public utility commission or local standards or guidelines that are being followed for dispatching the engine. The local balancing authority or local transmission and distribution system operator may keep these records on behalf of the engine owner or operator.

(ii) [Reserved]

(g) If you do not install, configure, operate, and maintain your engine and control device according to the manufacturer's emission-related written instructions, or you change emission-related settings in a way that is not permitted by the manufacturer, you must demonstrate compliance as follows:

(1)-(2) Not applicable.

(3) If you are an owner or operator of a stationary CI internal combustion engine greater than 500 HP, you must keep a maintenance plan and records of conducted maintenance and must, to the extent practicable, maintain and operate the engine in a manner consistent with good air pollution control practice for minimizing emissions. In addition, you must

**SECTION E. Source Group Restrictions.**

conduct an initial performance test to demonstrate compliance with the applicable emission standards within 1 year of startup, or within 1 year after an engine and control device is no longer installed, configured, operated, and maintained in accordance with the manufacturer's emission-related written instructions, or within 1 year after you change emission-related settings in a way that is not permitted by the manufacturer. You must conduct subsequent performance testing every 8,760 hours of engine operation or 3 years, whichever comes first, thereafter to demonstrate compliance with the applicable emission standards.

(h) Not applicable.

008 [40 CFR Part 60 Standards of Performance for New Stationary Sources §40 CFR 60.4214]

Subpart IIII - Standards of Performance for Stationary Compression Ignition Internal Combustion Engines

What are my notification, reporting, and recordkeeping requirements if I am an owner or operator of a stationary CI internal combustion engine?

(a) Not applicable.

(b) If the stationary CI internal combustion engine is an emergency stationary internal combustion engine, the owner or operator is not required to submit an initial notification. Starting with the model years in table 5 to this subpart, if the emergency engine does not meet the standards applicable to non-emergency engines in the applicable model year, the owner or operator must keep records of the operation of the engine in emergency and non-emergency service that are recorded through the non-resettable hour meter. The owner must record the time of operation of the engine and the reason the engine was in operation during that time.

(c) Not applicable.

(d) If you own or operate an emergency stationary CI ICE with a maximum engine power more than 100 HP that operates or is contractually obligated to be available for more than 15 hours per calendar year for the purposes specified in §60.4211(f)(2)(ii) and (iii) or that operates for the purposes specified in §60.4211(f)(3)(i), you must submit an annual report according to the requirements in paragraphs (d)(1) through (3) of this section.

(1) The report must contain the following information:

- (i) Company name and address where the engine is located.
- (ii) Date of the report and beginning and ending dates of the reporting period.
- (iii) Engine site rating and model year.
- (iv) Latitude and longitude of the engine in decimal degrees reported to the fifth decimal place.
- (v) Hours operated for the purposes specified in §60.4211(f)(2)(ii) and (iii), including the date, start time, and end time for engine operation for the purposes specified in §60.4211(f)(2)(ii) and (iii).
- (vi) Number of hours the engine is contractually obligated to be available for the purposes specified in §60.4211(f)(2)(ii) and (iii).
- (vii) Hours spent for operation for the purposes specified in §60.4211(f)(3)(i), including the date, start time, and end time for engine operation for the purposes specified in §60.4211(f)(3)(i). The report must also identify the entity that dispatched the engine and the situation that necessitated the dispatch of the engine.

(2) The first annual report must cover the calendar year 2015 and must be submitted no later than March 31, 2016. Subsequent annual reports for each calendar year must be submitted no later than March 31 of the following calendar year.

(3) The annual report must be submitted electronically using the subpart specific reporting form in the Compliance and Emissions Data Reporting Interface (CEDRI) that is accessed through EPA's Central Data Exchange (CDX) (www.epa.gov/cdx). However, if the reporting form specific to this subpart is not available in CEDRI at the time that the report is due, the written report must be submitted to the Administrator at the appropriate address listed in §60.4.

**SECTION E. Source Group Restrictions.**

(e) Not applicable.

**# 009 [40 CFR Part 60 Standards of Performance for New Stationary Sources §40 CFR 60.4218]
Subpart III - Standards of Performance for Stationary Compression Ignition Internal Combustion Engines
What parts of the General Provisions apply to me?**

Table 8 to this subpart shows which parts of the General Provisions in §§60.1 through 60.19 apply to you.

***** Permit Shield in Effect. *****

**SECTION E. Source Group Restrictions.**

Group Name: G09

Group Description: Alternative RACT II for Boiler 1 and 2

Sources included in this group

ID	Name
031	BOILER 1 WITH LOW NOX BURNER
032	BOILER 2 WITH LOW NOX BURNER

I. RESTRICTIONS.**Emission Restriction(s).****# 001 [25 Pa. Code §129.99]****Alternative RACT proposal and petition for alternative compliance schedule.**

(1) Emissions of NO_x expressed as NO₂ for Boiler 1 and 2 (Source ID 031 and 032) are individually limited to a maximum of 0.080 lb NO_x/MMBtu on a daily average basis. This limit excludes, emissions during start-up, shut-down, and malfunction; operation pursuant to emergency generation required by PJM, including any necessary testing for such emergency operations; and during periods in which compliance with this emission limit would require operation of any equipment in a manner inconsistent with technological limitations, good engineering and maintenance practices, and/or good air pollution control practices for minimizing emissions.

Startup means: The period in which operation of the EGU is initiated after a shutdown event for any purpose. Startup ends when any of the steam from the boiler is used to generate electricity for sale over the grid or for any other purpose (including on-site use). Any fraction of an hour in which startup occurs constitutes a full hour of startup.

Shutdown means: The period in which cessation of operation of an EGU is initiated for any purpose. Shutdown begins when the EGU no longer generates electricity or when no fuel is being fired in the EGU, whichever is earlier. Any fraction of an hour in which shutdown occurs constitutes a full hour of shutdown.

Daily average means: The total mass for each of the hours during the calendar day divided by the total heat input for each of the hours during the calendar day. This calculation methodology would also apply to the limit contained in (2), below.

(2) Emissions of NO_x expressed as NO₂ from Boiler 1 and 2 (Source ID 031 and 032) are individually limited to a maximum of 0.30 lb NO_x/MMBtu on a daily average basis under all operating conditions.

(3) Emissions of NO_x expressed as NO₂ from Boiler 1 and 2 (Source ID 031 and 032) are individually limited to a maximum 800 lbs NO_x/hr on a 30-operating day rolling average basis under all operating conditions.

II. TESTING REQUIREMENTS.

No additional testing requirements exist except as provided in other sections of this permit including Section B (Title V General Requirements).

III. MONITORING REQUIREMENTS.**# 002 [25 Pa. Code §127.511]****Monitoring and related recordkeeping and reporting requirements.**

The permittee shall monitor the following for Boiler 1 and 2 (Source ID 031 and 032):

- (a) The SCR inlet temperature, continuously, in order to determine compliance with the O&M Plan.
- (b) The permittee shall monitor and record the times at which the SCR inlet temperature transitions across the 600°F threshold.
- (c) The ammonia injection rate to the SCR, continuously, in order to determine compliance with the O&M Plan.

IV. RECORDKEEPING REQUIREMENTS.**# 003 [25 Pa. Code §127.441]****Operating permit terms and conditions.**

**SECTION E. Source Group Restrictions.**

All records shall be retained by the permittee for five (5) years and made available to the Department upon request.

004 [25 Pa. Code §127.511]**Monitoring and related recordkeeping and reporting requirements.**

The permittee shall keep records of the following for Boiler 1 and 2 (Source ID 031 and 032) to demonstrate compliance with 25 Pa. Code §129.99 in the following manner:

- (a) The SCR inlet temperature continuously with at least one reading every 15 minutes.
- (b) When the SCR inlet temperature transitions across the 600°F threshold.
- (c) The ammonia injection rate to the SCR hourly with at least one reading every hour.
- (d) The records must include sufficient data, including SCR inlet temperature for each boiler; times at which the SCR inlet temperature transitions across the 600°F threshold for each boiler; ammonia injection rate for each boiler, and calculations to demonstrate that the requirements of §129.99 are met.
- (e) Data or information required to determine compliance shall be recorded and maintained in a time frame consistent with the averaging period of the requirement.

005 [25 Pa. Code §129.100]**Compliance demonstration and recordkeeping requirements.**

In accordance with §129.100(d), the owner and operator of an air contamination source subject to this section and §§129.96-129.99 shall keep records to demonstrate compliance with §§129.96-129.99 in the following manner:

The records must include sufficient data and calculations to demonstrate that the requirements of 25 Pa. Code §§129.96 – 129.99 are met.

Data or information required to determine compliance shall be recorded and maintained in a time frame consistent with the averaging period of the requirement.

006 [25 Pa. Code §129.100]**Compliance demonstration and recordkeeping requirements.**

In accordance with §129.100(i), records shall be retained by the owner or operator for 5 years and made available to the Department or appropriate approved local air pollution control agency upon receipt of a written request from the Department or appropriate approved local air pollution control agency.

V. REPORTING REQUIREMENTS.**# 007 [25 Pa. Code §127.511]****Monitoring and related recordkeeping and reporting requirements.**

(a) The permittee shall submit quarterly reports to the Department for Boiler 1 and 2 (Source ID 031 and 032) of the following:

- (1) The SCR inlet temperature on an hourly average basis.
- (2) The ammonia injection rate to the SCR on an hourly average basis.

(b) The quarterly reports shall be submitted according to the following schedule:

- (1) The quarterly report for the period of January 1 - March 31 is due no later than April 30.
- (2) The quarterly report for the period of April 1 - June 30 is due no later than July 30.
- (3) The quarterly report for the period of July 1 - September 30 is due no later than October 30.
- (4) The quarterly report for the period of October 1 - December 31 is due no later than January 30.

VI. WORK PRACTICE REQUIREMENTS.**# 008 [25 Pa. Code §127.441]****Operating permit terms and conditions.**

**SECTION E. Source Group Restrictions.**

The owner or operator shall operate and maintain LNB in accordance with the manufacturer's specifications and in a manner consistent with good engineering and air pollution control practices.

009 [25 Pa. Code §127.441]**Operating permit terms and conditions.**

(a) Within 3 months of the effective date of this permit, the facility shall set the SCR at a target NOx emission rate of 0.060 lb NOx/MMBtu.

(b) After operating the SCR with an outlet NOx emission rate set-point of 0.060 lb/MMBtu for twelve consecutive months, the facility shall submit an engineering study within 180 days that analyzes the overall environmental performance of the system at that set-point.

010 [25 Pa. Code §127.441]**Operating permit terms and conditions.**

(a) The facility shall tune the boiler to minimize NOx emissions within 6 months of the effective date of this permit and annually thereafter.

(b) The facility shall maintain the following records of the tune-up:

1. The date of the tuning procedure.
2. The name of the service company and the technician performing the procedure.
3. The final operating rate or load.
4. The final NOx and CO emission rates.
5. The final excess oxygen rate.

011 [25 Pa. Code §127.441]**Operating permit terms and conditions.**

All operators of Boiler 1 and 2 (Source ID 031 and 032), SCR, and LNB shall be trained in the operation and maintenance of the unit(s) they are assigned to operate by qualified personnel.

012 [25 Pa. Code §129.99]**Alternative RACT proposal and petition for alternative compliance schedule.**

The owner or operator shall maintain NOx controls as effective as reasonably possible during startups and shutdowns.

013 [25 Pa. Code §129.99]**Alternative RACT proposal and petition for alternative compliance schedule.**

(a) The owner or operator shall take steps to bring NOx controls back into full service as quickly as practicable whenever the control equipment experiences a malfunction.

(b) The owner or operator shall document and report to the DEP, information regarding the cause of the malfunction and the steps for bringing the controls back.

014 [25 Pa. Code §129.99]**Alternative RACT proposal and petition for alternative compliance schedule.**

The owner or operator shall develop, maintain, and implement an operation and maintenance plan (O&M Plan) for Boiler 1 and 2 (Source ID 031 and 032) and the SCR within 30-days of issuance of this Permit. The O&M Plan shall include, but not be limited to the following:

(a) Inspection, repairs, and preventive maintenance procedures to be followed to ensure proper operation of the Boiler 1 and 2 and SCR system and continuing compliance with the applicable emission limits specified in this Permit.

(b) A description of preventive maintenance schedules, spare parts inventories, procedures and protocols for unscheduled outages, and provisions for equipment replacement and measures to be taken to protect SCR system in the event of failure or shutdown.

(c) Inspections of duct work and boiler casing and repairs of leaks to maintain flue gas temperature.

(d) Details of the practices and procedures to be followed during periods of startup, shutdown and upset conditions in order to prevent emissions in excess of the standards specified in this permit.

SECTION E. Source Group Restrictions.**# 015 [25 Pa. Code §129.99]****Alternative RACT proposal and petition for alternative compliance schedule.**

The owner or operator shall develop, maintain, and implement an operation and maintenance plan (O&M Plan) for Boiler 1 and 2 (Source ID 031 and 032) and LNB within 30-days of issuance of this Permit. The O&M Plan shall include, but not be limited to the following:

- (a) Inspection, repairs, and preventive maintenance procedures to be followed to ensure proper operation of the Boiler 1 and 2 (Source ID 031 and 032) and LNB and continuing compliance with the emission standards specified in this Permit.
- (b) A description of preventive maintenance schedules, spare parts inventories, procedures and protocols for unscheduled outages, and provisions for equipment replacement and measures to be taken to protect air pollution control equipment in the event of any control equipment failure or shutdown.
- (c) Details of the practices and procedures to be followed during periods of startup, shutdown and upset conditions in order to prevent emissions in excess of the standards specified in this permit.
- (d) Inspections, repair and testing of Over Fire Air (OFA) components.
- (e) Details of the practices and procedures to be followed to ensure that the boiler is tuned to optimize NO_x reduction over combustion efficiency, including but not limited to the properly adjusted burner angle.

016 [25 Pa. Code §129.99]**Alternative RACT proposal and petition for alternative compliance schedule.**

The owner or operator shall calibrate, operate, and maintain all elements of the SCR system and units in accordance with the manufacturer's specifications, in a manner consistent with good engineering and air pollution control practices when the SCR system is in use.

017 [25 Pa. Code §129.99]**Alternative RACT proposal and petition for alternative compliance schedule.**

- (a) During the first 60-days of each calendar year, the facility shall perform a catalyst activity test.
- (b) Within 60 days of receiving the results of catalyst activity test, the facility shall consult with the SCR catalyst vendor to monitor SCR performance in accordance with the catalyst management plans (CMPs) developed for the SCR systems. Corrective action, if required, shall be completed by April 30th.

VII. ADDITIONAL REQUIREMENTS.**# 018 [25 Pa. Code §127.441]****Operating permit terms and conditions.**

In accordance with §129.99(g), the emission limit and requirements specified in the plan approval or operating permit issued by the Department or appropriate approved local air pollution control agency under subsection (f) supersede the emission limit and requirements in the existing plan approval or operating permit issued to the owner or operator of the source prior to April 23, 2016, on the date specified in the plan approval or operating permit issued by the Department or appropriate approved local air pollution control agency under subsection (f), except to the extent the existing plan approval or operating permit contains more stringent requirements.

***** Permit Shield in Effect. *****

**SECTION E. Source Group Restrictions.**

Group Name: G10

Group Description: NOx CEMs Requirements

Sources included in this group

ID	Name
031	BOILER 1 WITH LOW NOX BURNER
032	BOILER 2 WITH LOW NOX BURNER

I. RESTRICTIONS.

No additional requirements exist except as provided in other sections of this permit including Section B (Title V General Requirements).

II. TESTING REQUIREMENTS.

No additional testing requirements exist except as provided in other sections of this permit including Section B (Title V General Requirements).

III. MONITORING REQUIREMENTS.**# 001 [25 Pa. Code §127.441]****Operating permit terms and conditions.**

[Additional authority for this permit condition is derived from, 40 CFR Part 75, 40 CFR Sections 52.2020, and 25 Pa. Code Sections 139.4, & 139.101]

a. Continuous Emission Monitoring Requirements

1. The following continuous emission monitoring systems (CEMS) must be installed, approved by the Department, operated and maintained in accordance with the requirements of 25 Pa. Code Chapter 139, Subchapter C (relating to requirements for source monitoring for stationary sources), and the "Submittal and Approval", "Record Keeping and Reporting", and "Quality Assurance" requirements of Revision No. 8 of the Department's Continuous Source Monitoring Manual, 274-0300-001.

For Source: Boiler 1 and 2 (Source ID 031 and 032)

Pollutant	Measurement	Averaging Period	Standard	Basis
NOx	lb/MMBtu	Calendar Day	0.080 lb/MMBtu	Continuously excluding emissions during start-up, shut-down, and malfunction; operation pursuant to emergency generation required by PJM, including any necessary testing for such emergency operations; and during periods in which compliance with this emission limit would require operation of any equipment in a manner inconsistent with technological limitations, good engineering and maintenance practices, and/or good air pollution control practices for minimizing emissions
NOx	lb/MMBtu	Calendar Day	0.30 lb/MMBtu	Continuously under all operating conditions
NOx	lb/hr	30-operating day	800 lb/hr	Continuously under all operating conditions

Note: Compliance with any subsequently issued revisions to the Continuous Source Monitoring Manual will constitute compliance with the terms of this permit condition.

b. Data Availability Standards

1. The continuous emission monitoring systems (CEMS) for NOx are required by 25 Pa. Code §139.101(12) to meet at

**SECTION E. Source Group Restrictions.**

least one of the following minimum data availability requirements unless other data availability requirements are stipulated elsewhere:

- i In each calendar month, at least 90% of the time periods for which an emission standard or an operational parameter applies shall be valid as set forth in the Quality Assurance section of Revision No. 8 of the Department's Continuous Source Monitoring Manual, 274-0300-001).
- ii In each calendar quarter, at least 95% of the hours shall be valid as set forth in the Quality Assurance section of the Manual (Revision No. 8 of the Department's Continuous Source Monitoring Manual, 274-0300-001).

Note: Compliance with any subsequently issued revisions to the Continuous Source Monitoring Manual will constitute compliance with the terms of this permit condition.

c. Certification and Testing Requirements

i. Initial Application (Phase I)

Upon promulgation of a monitoring requirement, a proposal containing information as listed in the Phase I section of the Department's Continuous Source Monitoring Manual for the proposed CEMS must be submitted to the Department 180 days prior to the initial startup of a new source and within 180 days of promulgation of a monitoring requirement for an existing source.

ii. Performance Testing (Phase II)

After approval of Phase I, the applicant shall proceed with purchasing, installation, and performance testing. The CEM Section must be advised in writing at least 45 days prior to Performance Specification Testing to provide the opportunity to observe and participate in all testing. A testing protocol, describing all testing procedures and methodology to be used must accompany the notice of testing. Schedule changes must be reported seven days prior to testing except that failed tests may be repeated immediately. Testing as listed in the Phase II section of the Department's Continuous Source Monitoring Manual must be completed for the CEMS[s] no later than 180 days after initial source startup and no later than 60 days after the source achieves normal process capacity. During testing, the source must be operated in a manner that is representative of normal operating conditions. All other notifications and performance specification testing must be conducted in accordance with the Department's Continuous Source Monitoring Manual.

iii. Final Approval (Phase III)

The final report of testing as listed in the Phase III section of the Department's Continuous Source Monitoring Manual must be submitted to the Bureau no later than 60 days after completion of the testing. The owner or operator of the source shall not be issued an operating permit until the CEMS have received Phase III approval, in writing from the Department, when installation of a CEMS is made a condition of the plan approval. Until Phase III Department approval is obtained, operation shall be covered solely under condition of a plan approval.

Note: Compliance with any subsequently issued revisions to the Continuous Source Monitoring Manual will constitute compliance with the terms of this permit condition.

IV. RECORDKEEPING REQUIREMENTS.

002 [25 Pa. Code §127.441]

Operating permit terms and conditions.

[Additional authority for this permit condition is derived from 40 CFR Part 75, 40 CFR Sections 52.2020, and 25 Pa. Code Sections 139.101(5) and 139.101(12).]

1. The permittee shall comply with the recordkeeping requirements established in 25 Pa. Code Chapter 139, Subchapter C (relating to requirements for source monitoring for stationary sources), the "Record Keeping and Reporting" requirements in the Department's Continuous Source Monitoring Manual, Revision No. 8, 274-0300-001.

2. Records shall be retained for at least 5 years and shall be made available to the Department upon request.

Note: Compliance with any subsequently issued revision to the Continuous Source Monitoring Manual will constitute compliance with this permit condition.

**SECTION E. Source Group Restrictions.****V. REPORTING REQUIREMENTS.****# 003 [25 Pa. Code §127.441]****Operating permit terms and conditions.**

Reporting Requirements:

[Additional authority for this permit condition is derived from, 40 CFR Part 75, 40 CFR Sections 52.2020, and 25 Pa. Code Sections 139.101(1)(iv)4, 139.101(10) & 139.101(12)]

1. The permittee shall submit quarterly reports of continuous emission monitoring to the Department in accordance with the requirements established in 25 Pa. Code Chapter 139, Subchapter C (relating to requirements for source monitoring for stationary sources), the "Record Keeping and Reporting" requirements as established in the Department's Continuous Source Monitoring Manual, Revision No. 8, 274-0300-001.
2. The permittee shall report emissions for all periods of unit operation, including startup, shutdown and malfunction.
3. Initial quarterly reports following system certification shall be submitted to the Department within 35 days following the date upon which the Department notifies the owner or operator, in writing, of the approval of the continuous source monitoring system for use in determining compliance with applicable emission standards.
4. Subsequent quarterly reports shall be submitted to the Department within 30 days after the end of each calendar quarter.
5. Failure to submit required reports of continuous emission monitoring within the time periods specified in this Condition, shall constitute violations of this Permit, unless approved in advance by the Department in writing.

Note: Compliance with any subsequently issued revision to the Continuous Source Monitoring Manual will constitute compliance with this permit condition.

VI. WORK PRACTICE REQUIREMENTS.

No additional work practice requirements exist except as provided in other sections of this permit including Section B (Title V General Requirements).

VII. ADDITIONAL REQUIREMENTS.**# 004 [25 Pa. Code §127.441]****Operating permit terms and conditions.**

Quality Assurance Requirements:

[Additional authority for this permit condition is derived from, 40 CFR Part 75, 40 CFR Sections 52.2020, and 25 Pa. Code Sections 139.101(1)(iv), 139.101(2), 139.101(3), 139.101(4), 139.101(6), 139.101(7), 139.101(8), 139.101(12), 139.101(14), and 139.101(15)]

Continuous Emission Monitoring Systems and components must be operated and maintained in accordance with the requirements established in 25 Pa. Code Chapter 139, Subchapter C (relating to requirements for source monitoring for stationary sources), the "Quality Assurance" requirements in the Department's Continuous Source Monitoring Manual, Revision No. 8, 274-0300-001.

Note: Compliance with any subsequently issued revision to the Continuous Source Monitoring Manual will constitute compliance with this permit condition.

005 [25 Pa. Code §127.441]**Operating permit terms and conditions.**

[25 Pa. Code §127.441(c) & Chapter 139; §§114(a)(3), 504(b) of the CAA] Sampling, Testing and Monitoring Procedures

The permittee shall perform the emissions monitoring analysis procedures or test methods required under an applicable requirement including procedures and methods under Sections 114(a)(3) (42 U.S.C.A. §§ 7414 (a)(3)) or 504(b) (42 U.S.C.A. §§ 7661c(b)) of the Clean Air Act.

Note: Compliance with any subsequently issued revision to the Continuous Source Monitoring Manual will constitute compliance with this permit condition.



SECTION E. Source Group Restrictions.

***** Permit Shield in Effect. *****

**SECTION E. Source Group Restrictions.**

Group Name: G11

Group Description: Alternative RACT II for Auxiliary Boilers

Sources included in this group

ID	Name
037	AUX BOILER A
038	AUX BOILER B

I. RESTRICTIONS.**Emission Restriction(s).****# 001 [25 Pa. Code §129.99]****Alternative RACT proposal and petition for alternative compliance schedule.**

(a) Emissions of NO_x, expressed as NO₂, for the Auxiliary Boilers A and B (Source ID 037 and 038) are individually limited to a maximum of 0.22 lb NO_x/MMBtu on a daily average basis.

(b) Emissions of NO_x, expressed as NO₂, for the Auxiliary Boilers A and B (Source ID 037 and 038) are individually limited to a maximum of 13.3 tpy based on a 12-month rolling total.

002 [25 Pa. Code §129.99]**Alternative RACT proposal and petition for alternative compliance schedule.**

Auxiliary Boilers A and B (Source ID 037 and 038) shall each not exceed a 10% annual heat input capacity factor.

[Pursuant to 25 Pa. Code Sections 129.91-192.95 (RACT I Operating Permit No. 03-000-027) and 25 Pa. Code Sections 129.96-129.100]

II. TESTING REQUIREMENTS.**# 003 [25 Pa. Code §129.99]****Alternative RACT proposal and petition for alternative compliance schedule.**

A minimum of one (1) stack test in accordance with in 25 Pa. Code, Chapter 139, Subchapter A (relating to sampling and testing methods and procedures) and the Department Source Testing Manual shall be performed on Auxiliary Boiler A and B (Source ID 037 and 038) during each five (5) calendar year period to verify the emission rates for NO_x. This test should be conducted between 6 to 18 months prior to the operating permit expiration date.

[Also authorized by 25 Pa. Code Section 129.100(a)(4)]

III. MONITORING REQUIREMENTS.

No additional monitoring requirements exist except as provided in other sections of this permit including Section B (Title V General Requirements).

IV. RECORDKEEPING REQUIREMENTS.**# 004 [25 Pa. Code §127.441]****Operating permit terms and conditions.**

All records shall be retained by the permittee for five (5) years and made available to the Department upon request.

005 [25 Pa. Code §129.100]**Compliance demonstration and recordkeeping requirements.**

In accordance with §129.100(d), the owner and operator of an air contamination source subject to this section and §§129.96-129.99 shall keep records to demonstrate compliance with §§129.96-129.99 in the following manner:

The records must include sufficient data and calculations to demonstrate that the requirements of 25 Pa. Code §§129.96 – 129.99 are met.

Data or information required to determine compliance shall be recorded and maintained in a time frame consistent with the averaging period of the requirement.

**SECTION E. Source Group Restrictions.****# 006 [25 Pa. Code §129.100]****Compliance demonstration and recordkeeping requirements.**

In accordance with §129.100(i), records shall be retained by the owner or operator for 5 years and made available to the Department or appropriate approved local air pollution control agency upon receipt of a written request from the Department or appropriate approved local air pollution control agency.

007 [25 Pa. Code §129.99]**Alternative RACT proposal and petition for alternative compliance schedule.**

Maintain an operating log for the Auxiliary Boilers A and B (Source ID 037 and 038) to verify that the annual capacity limit is not exceeded.

The permittee shall maintain an operating log, including records of hours of operation, fuel consumption, fuel type, and typical fuel analyses to verify compliance with the annual capacity factor limitation of 10%.

[Pursuant to 25 Pa. Code Sections 129.91-192.95 (RACT I Operating Permit No. 03-000-027) and 25 Pa. Code Sections 129.96-129.100]

V. REPORTING REQUIREMENTS.

No additional reporting requirements exist except as provided in other sections of this permit including Section B (Title V General Requirements).

VI. WORK PRACTICE REQUIREMENTS.

No additional work practice requirements exist except as provided in other sections of this permit including Section B (Title V General Requirements).

VII. ADDITIONAL REQUIREMENTS.**# 008 [25 Pa. Code §127.441]****Operating permit terms and conditions.**

In accordance with §129.99(g), the emission limit and requirements specified in the plan approval or operating permit issued by the Department or appropriate approved local air pollution control agency under subsection (f) supersede the emission limit and requirements in the existing plan approval or operating permit issued to the owner or operator of the source prior to April 23, 2016, on the date specified in the plan approval or operating permit issued by the Department or appropriate approved local air pollution control agency under subsection (f), except to the extent the existing plan approval or operating permit contains more stringent requirements.

***** Permit Shield in Effect. *****

SECTION F. Alternative Operation Requirements.

Alternative Operation Name: OPTIONAL SORBENT INJECTION SYSTEM 1

#001 CHANGES FROM NORMAL OPERATION

Use of optional Sorbent Injection System.

Sources included in this Alternative Operation:

ID	Name	Source Type
031	BOILER 1 WITH LOW NOX BURNER	Combustion Unit

Alternative Operation Map:

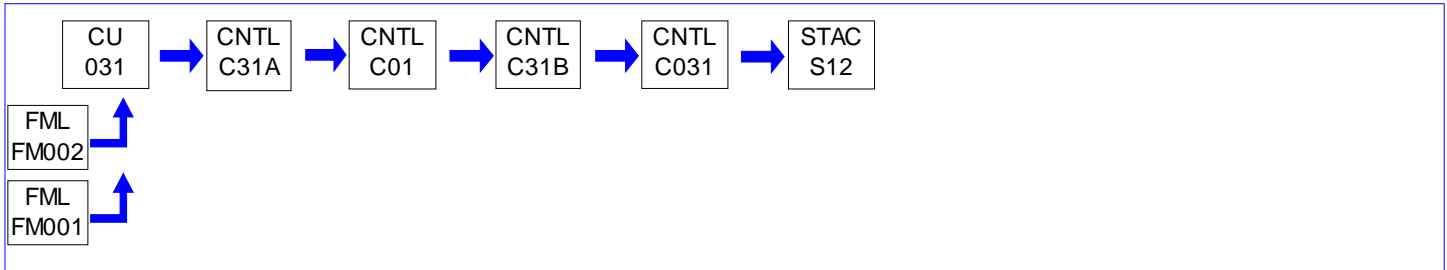

I. RESTRICTIONS.

No additional requirements exist except as provided in other sections of this permit including Section B (Title V General Requirements) and/or Section E (Source Group Restrictions).

II. TESTING REQUIREMENTS.

No additional testing requirements exist except as provided in other sections of this permit including Section B (Title V General Requirements) and/or Section E (Source Group Restrictions).

III. MONITORING REQUIREMENTS.

No additional monitoring requirements exist except as provided in other sections of this permit including Section B (Title V General Requirements) and/or Section E (Source Group Restrictions).

IV. RECORDKEEPING REQUIREMENTS.

No additional record keeping requirements exist except as provided in other sections of this permit including Section B (Title V General Requirements) and/or Section E (Source Group Restrictions).

V. REPORTING REQUIREMENTS.

No additional reporting requirements exist except as provided in other sections of this permit including Section B (Title V General Requirements) and/or Section E (Source Group Restrictions).

VI. WORK PRACTICE REQUIREMENTS.

No additional work practice requirements exist except as provided in other sections of this permit including Section B (Title V General Requirements) and/or Section E (Source Group Restrictions).

VII. ADDITIONAL REQUIREMENTS.

No additional requirements exist except as provided in other sections of this permit including Section B (Title V General Requirements) and/or Section E (Source Group Restrictions).

SECTION F. Alternative Operation Requirements.

Alternative Operation Name: OPTIONAL SORBENT INJECTION SYSTEM 2

#001 CHANGES FROM NORMAL OPERATION

Use of optional Sorbent Injection System.

Sources included in this Alternative Operation:

ID	Name	Source Type
032	BOILER 2 WITH LOW NOX BURNER	Combustion Unit

Alternative Operation Map:

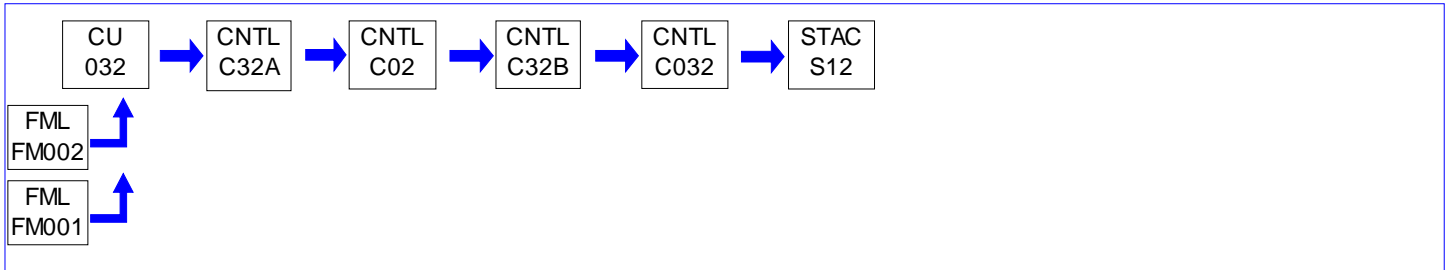

I. RESTRICTIONS.

No additional requirements exist except as provided in other sections of this permit including Section B (Title V General Requirements) and/or Section E (Source Group Restrictions).

II. TESTING REQUIREMENTS.

No additional testing requirements exist except as provided in other sections of this permit including Section B (Title V General Requirements) and/or Section E (Source Group Restrictions).

III. MONITORING REQUIREMENTS.

No additional monitoring requirements exist except as provided in other sections of this permit including Section B (Title V General Requirements) and/or Section E (Source Group Restrictions).

IV. RECORDKEEPING REQUIREMENTS.

No additional record keeping requirements exist except as provided in other sections of this permit including Section B (Title V General Requirements) and/or Section E (Source Group Restrictions).

V. REPORTING REQUIREMENTS.

No additional reporting requirements exist except as provided in other sections of this permit including Section B (Title V General Requirements) and/or Section E (Source Group Restrictions).

VI. WORK PRACTICE REQUIREMENTS.

No additional work practice requirements exist except as provided in other sections of this permit including Section B (Title V General Requirements) and/or Section E (Source Group Restrictions).

VII. ADDITIONAL REQUIREMENTS.

No additional requirements exist except as provided in other sections of this permit including Section B (Title V General Requirements) and/or Section E (Source Group Restrictions).

***** Permit Shield in Effect. *****

**SECTION G. Emission Restriction Summary.**

Source Id	Source Descriptor		
031	BOILER 1 WITH LOW NOX BURNER		
Emission Limit		Pollutant	
5.000	PPMV		Ammonia
0.080	Lbs/MMBTU	on a daily average basis	NOX
0.300	Lbs/MMBTU	on a daily average basis under all operating conditions	NOX
0.450	Lbs/MMBTU	Thirty-Day Rolling Average	NOX
800.000	Lbs/Hr	on a 30-operating day rolling average basis under all operating conditions	NOX
0.100	Lbs/MMBTU	(Filterable & Condensable)	PM10
1.200	Lbs/MMBTU	Thirty-Day Rolling Average	SO2
9,600.000	Lbs/Hr	24-hour (daily) block average basis (combined units)	SO2
0.100	Lbs/MMBTU	(Filterable only)	TSP
032	BOILER 2 WITH LOW NOX BURNER		
Emission Limit		Pollutant	
5.000	PPMV		Ammonia
0.080	Lbs/MMBTU	on a daily average basis	NOX
0.300	Lbs/MMBTU	on a daily average basis under all operating conditions	NOX
0.450	Lbs/MMBTU	Thirty-Day Rolling Average	NOX
800.000	Lbs/Hr	on a 30-operating day rolling average basis under all operating conditions	NOX
0.100	Lbs/MMBTU	(Filterable & Condensable)	PM10
1.200	Lbs/MMBTU	Thirty-Day Rolling Average	SO2
9,600.000	Lbs/Hr	24-hour (daily) block average basis (combined units)	SO2
0.100	Lbs/MMBTU	(Filterable only)	TSP
037	AUX BOILER A		
Emission Limit		Pollutant	
0.220	Lbs/MMBTU	on a daily average basis	NOX
13.300	Tons/Yr	on a 12-month rolling total	NOX
4.000	Lbs/MMBTU	over any 1-hr period	SO2
0.228	Lbs/MMBTU		TSP
038	AUX BOILER B		
Emission Limit		Pollutant	
0.220	Lbs/MMBTU	on a daily average basis	NOX
13.300	Tons/Yr	on a 12-month rolling total	NOX
4.000	Lbs/MMBTU	over any 1-hr period	SO2
0.228	Lbs/MMBTU		TSP
115	FIRED SPACE AND MISCELLANEOUS HEATERS		
Emission Limit		Pollutant	
500.000	PPMV	dry basis	SOX

**SECTION G. Emission Restriction Summary.**

Source Id	Source Descriptor		
101	UNIT 3 PEAKING DIESEL GENERATOR (3,600-BHP)		
Emission Limit		Pollutant	
500.000	PPMV		SO2
0.040	gr/DRY FT3		TSP
102	UNIT 4 PEAKING DIESEL GENERATOR (3,600-BHP)		
Emission Limit		Pollutant	
500.000	PPMV		SO2
0.040	gr/DRY FT3		TSP
103	UNIT 5 PEAKING DIESEL GENERATOR (3,600-BHP)		
Emission Limit		Pollutant	
500.000	PPMV		SO2
0.040	gr/DRY FT3		TSP
104	UNIT 6 PEAKING DIESEL GENERATOR (3,600-BHP)		
Emission Limit		Pollutant	
500.000	PPMV		SO2
0.040	gr/DRY FT3		TSP
107	ASH DISPOSAL		
Emission Limit		Pollutant	
0.040	gr/DRY FT3		TSP
110	EMERGENCY ENGINES (910HP GEN, 217 & 200HP FIRE PUMPS)		
Emission Limit		Pollutant	
500.000	PPMV	DRY BASIS	SOX
500.000	PPMV		SOX
0.040	gr/DRY FT3		TSP
111	LIMESTONE HANDLING, PROCESSING, AND STORAGE OPERATIONS		
Emission Limit		Pollutant	
0.022	gr/DRY FT3	Bin Vents	TSP
113	EMERGENCY QUENCH PUMPS/ENGINES (2-130HP & 2,328-BHP)		
Emission Limit		Pollutant	
2.600	GRAMS/HP-Hr		CO
6.900	GRAMS/HP-Hr		NOX
0.040	gr/DRY FT3		PM10
500.000	PPMV	DRY BASIS	SOX
0.400	GRAMS/HP-Hr		TSP
114	EMERGENCY DIESEL GENERATOR (1,474-BHP ENG., 1,000-KW OUTPUT)		
Emission Limit		Pollutant	
2.610	GRAMS/HP-Hr		CO
4.770	GRAMS/HP-Hr		NOx+NMHC



SECTION G. Emission Restriction Summary.

Source Id	Source Description		
500.000	PPMV	DRY BASIS	SOX
0.040	gr/DRY FT3		TSP
0.150	GRAMS/HP-Hr		TSP

Site Emission Restriction Summary

Emission Limit	Pollutant
----------------	-----------

Alternative Operation Emission Restriction Summary

Source Id	Source Description
-----------	--------------------

**SECTION H. Miscellaneous.**

1. The capacities/throughputs listed in Section A, D, and E, excluding those in permit restrictions, are for informational purposes only and are not enforceable limits.

2. The following description of the emission processes at Keystone is for information purposes only:

This Operating Permit authorizes the Operation of an Electric Generating Plant known as the Keystone Station, located in Plumcreek Township, Armstrong County. The main sources at this facility are two (2) pulverized coal-fired (PC) boilers (Source IDs 031 and 032), with nominal fuel heat inputs of 8,717 MMBtu/hour. Each boiler powers an electrical generator with a nameplate capacity of 936-MW, for a combined capacity of 1,872-MW. Emissions from the PC boilers are controlled by wet limestone scrubbers (Control IDs C031 and C032) to control sulfur dioxide (SO₂) emissions, low NO_x burners and selective catalytic reduction systems (SCR) (Control IDs C31A and C32A) to control NO_x emissions, and electrostatic precipitators (ESP) (Control IDs C01 and C02) to control PM emissions. Collection of SO₂, heavy metals, and acid gases, including hydrochloric acid and hydrofluoric acid, takes place in the wet scrubbers. The boilers are able to comply with NO_x emission limits with the SCR systems out of service. The SCR systems are operated at the option of the company and reduce the number of NO_x emission credits from a NO_x trading program, used by the station. Normally, SCR is operated only during the five month (May-September) "ozone" season. Operation of the SCR systems is included in the permit as an Alternative Operation Scenario. Each boiler train is also equipped with an optional Sorbent Injection System (Control IDs C31B and C32B) for control of SO₃. Sorbent injection can be concurrent with, or independent of SCR operation. Both boilers discharge to a dual-flue stack (Stack ID S12). No. 2 fuel oil is combusted during startup.

Supporting equipment at this site includes two 138 MMBtu/hour auxiliary boilers, four 3,600-BHP peaking diesel electrical generators, three emergency diesel generators (2400 bhp, 1500 bhp, and 2300 bhp), limestone processing, emergency quench pumps, coal storage piles, plant roads, and gypsum production.

3. Source #110 Emergency Engines is comprised of the following equipment:

910 bhp Emergency Diesel Generator (associated with Unit 1 Boiler turbines and oil pumps)

Two Detroit Diesel Fire Pumps, 217 hp and 200 hp, used for fire protection by pulling water from hydrants supplied by cooling towers in an emergency.

4. Source 111 Limestone Handling, Processing, and Storage Operations consists of 3 dust collectors. DC-1 Limestone receiving area, DC-2 Limestone Reclaim Area, and DC-3 Limestone silo located in the FGD Building (vents indoors). This source also consists of the rail unloading, truck unloading, and stockpile.

5. Source 112 Gypsum Production, Processing and Handling consists of gypsum vacuum filter, wallboard quality stackout conveyor inside Dome, discharge of off-spec gypsum stackout located on westside of Dome, and trucking to landfill and stockpiling.

6. Source #113 Emergency Engine/Pumps consists of 2 quench pumps, 149hp each, 2328 hp diesel engine

7. Source #115 Fired Space and Misc. Heaters is comprised of the following equipment: Propane-fired Space Heaters and No. 2 Oil-fired Heaters.

8. The following have been identified as insignificant sources/activities at this facility:

- General storage tanks
- General storage tanks (HAPs)
- Fly ash silos
- Lime silos
- Cylinder gasses for CEMs
- Water treatment systems
- Support systems equipment
- Battery room
- Transformers
- Lube oil reservoir vapor extractors
- Miscellaneous boiler house vents
- Miscellaneous vented equipment
- Contractor equipment

**SECTION H. Miscellaneous.**

Diethylene Glycol Usage
FGD Hydrated Lime Silo (WWT)
FGD WPT Clarifier
FGD WWT Cooling Tower
FGD WWT and WPT Totes

9. The following person has been identified as an additional Responsible Official for the GenOn Northeast Management Company - Keystone Station:

Mark Gouveia – Senior Vice President
Telephone (301)843-4410

10. The Acid Rain Permit application is attached to this TVOP as Attachment 1, as instructed by EPA, Region 3.

11. [Reserve]

12. This permit was administratively amended on October 7, 2019 to incorporate the change of ownership and correct typographical errors in the permit.

13. Effective January 1, 2020, the following person has been identified as an additional Responsible Official for the Keystone Station:

Luke Henderson
Sr. Operations Director
Consolidated Asset Management Services
801 Corporate Center Drive Suite 116
Raleigh, NC 27607

14. For permit reference, Unit 1 and 2 refer to Boiler 1 and 2.



***** End of Report *****

