

DEPARTMENT OF ENVIRONMENTAL PROTECTION
Bureau of District Mining Operations

- DOCUMENT NUMBER:** 563-0300-101
- TITLE:** Engineering Manual for Surface Mining Operations
- EFFECTIVE DATE:** Upon publication of notice as final in the *Pennsylvania Bulletin*
- AUTHORITY:** The Clean Streams Law (35 P.S. §§ 691.1-691.1001); Noncoal Surface Mining Conservation and Reclamation Act (52 P.S. § 3311(a); Surface Mining Conservation and Reclamation Act (52 P.S. §§ 1396.1-1396.31); Coal Refuse Disposal Control Act (52 P.S. §§ 30.51-30.66); Administrative Code of 1929 (71 P.S. 510-1-510-108); Air Pollution Control Act (35 P.S. §§ 4001 – 4014; and implementing regulations including, but not limited to, 25 Pa. Code Chapters 77, 86, 87, 88, 92a, and 93.
- POLICY:** The Pennsylvania Department of Environmental Protection (PADEP or the Department) establishes its policy through this manual for assisting coal and noncoal surface mine operators with implementation of certain engineering requirements in 25 Pa. Code Chapters 77, 86, 87, 88, 92a.
- PURPOSE:** This guidance document provides assistance in the areas of the surface mining permit applications that involve engineering, such as the Erosion and Sediment Control Plan, water treatment plans, the air pollution control plan, stream encroachments, wetlands, haul roads, culverts, effluent requirements, special protection watersheds, and areas where mining is restricted. While the permit applications for each type of mining activity are specific as to what information is required, this guidance document explains acceptable design methods and suitable variations. This guidance document is intended for the use of mine operators, consultants, and Department staff.
- APPLICABILITY:** All surface coal and noncoal operators
- DISCLAIMER:** The policies and procedures outlined in this guidance are intended to supplement existing requirements. Nothing in the policies or procedures shall affect regulatory requirements.
- The policies and procedures herein are not an adjudication or a regulation. DEP does not intend to give this guidance that weight or deference. This document establishes the framework, within which DEP will exercise its administrative discretion in the future. DEP reserves the discretion to deviate from this policy statement if circumstances warrant.
- PAGE LENGTH:** 147 pages

Commonwealth of Pennsylvania



pennsylvania
DEPARTMENT OF ENVIRONMENTAL
PROTECTION

Engineering Manual for Surface Mining Operations

Bureau of District Mining Operations
Pennsylvania Department of Environmental Protection

www.dep.pa.gov

ACKNOWLEDGEMENTS

The following individuals and organizations participated in updating this manual. Participation does not infer concurrence or endorsement of the manual or its contents.

E & S Manual Oversight Committee:

Alan Bigatel, P.E., PA DEP
Roger Bowman, P.E., PA DEP
Joe Blyler, P.E., PA DEP
Nicholas Craven, E.I.T., PA DEP
Jess Heydenreich, PA DEP
Kimberly Murnyack, E.I.T., PA DEP
Tom Nalisnick, P.E., PA DEP
Lori Odenthal, P.G., PA DEP
Richard Palmer, P.E., PA DEP
William Plassio, P.E., PA DEP
Bernie Robb, P.E., PA DEP
Michael W. Smith, P.G., PA DEP
Gregory G. Shuler, P.G., PA DEP
Christopher Vought, P.E., PA DEP
Brent Means, P.G., Office of Surface Mining Reclamation and Enforcement -
U.S. Department of the Interior
Office of Water Management, Bureau of Waterways Engineering, PA DEP
Pennsylvania Aggregate and Concrete Association
Pennsylvania Coal Association
Earthtech, Inc. (Illustrations)
GeoTech Engineering, Inc (Illustrations)

TABLE OF CONTENTS

1.0 Introduction..... 1

1.1 Acronyms..... 2

2.0 Erosion and Sedimentation Control..... 4

2.1 Different Types of Erosion 4

2.1.1 Raindrop Erosion 5

2.1.2 Sheet Erosion 5

2.1.3 Rill Erosion 5

2.1.4 Gully Erosion 6

2.1.5 Channel Erosion..... 6

2.2 Regulations 6

2.2.1 Sediment Pollution..... 7

2.3 Erosion and Sedimentation Control Plan (E&SCP) (25 Pa. Code §§ 77.525, 87.70, 87.106, 88.50, 89.21, 90.37, 90.106, 102.4) 8

2.4 Control Measures That Reduce Erosion and Sedimentation (25 Pa. Code §§ 77.525, 87.70, 87.106, 88.50, 89.21, 90.37, 90.106, 102.4) 9

2.4.1 Limiting Exposed Area 9

2.4.2 Surface Water Diversion..... 9

2.4.3 Velocity Control..... 9

2.4.4 Permanent Stabilization 12

2.4.5 Temporary Stabilization..... 12

2.4.6 Collection of Runoff 12

2.4.7 Sediment Pollution Control..... 12

2.4.9 Perimeter Controls 12

2.4.10 Infiltration 12

2.5 Hydrology 13

2.6 Channels..... 14

2.6.1 Upslope and Highwall Diversion Channels (25 Pa. Code §§ 77.524, 87.105, 88.95, 102.12) 14

2.6.2 Diversion Channel Design Considerations 14

2.6.3 Collection Channels (25 Pa. Code §§ 77.525, 87.106, 88.96, and 102.13) 15

2.7 Vegetation-Lined Channels 16

2.8 Rock-Lined Channels..... 17

2.8.1 Rock Filters..... 20

2.9 Other Erosion and Sedimentation Controls 21

2.9.1 Silt Fence 21

2.9.2 Super Silt Fence 25

2.9.3 Straw Bale Barrier..... 26

2.9.4 Sediment Traps 28

2.9.5 Compost Filter Socks..... 30

2.9.6 Earthen Berms..... 32

2.9.7 Vegetated Strips 32

3.0 Sediment Control Impoundments 33

3.1 Chapter 105 Impoundments (Title 25 Pa. Code §§ 87.112, 88.102 and 105.3) 35

FOR DISCUSSION PURPOSES ONLY (AGGREGATE ADVISORY BOARD)

3.2	Permanent Impoundments (25 Pa. Code §§ 77.530, 87.111, 88.101, 88.196 and 88.301)	36
3.3	Mine Safety and Health Administration Impoundments (30 CFR 77.216-1 and 77.216-2, and 25 Pa. Code § 87.112)	37
3.4	Combined Sediment and Treatment Impoundments	37
3.5	Pond Design (25 Pa. Code §§ 77.531, 87.73, 87.112)	38
3.6	Pond Certification – Post-Construction (25 Pa. Code § 87.112)	38
3.7	Pond Examinations and Inspections (25 Pa. Code § 87.112)	38
3.8	Impoundment Capacity (25 Pa. Code §§ 87.108 and 102.13)	39
3.9	Principal Spillway (25 Pa. Code § 87.112, and NRCS Sediment Basin 350 and Pond 378)	40
3.10	Emergency Spillway (25 Pa. Code §§ 102.13, 105.98, and NRCS Sediment Basin 350 and Pond 378)	42
3.11	Freeboard (25 Pa. Code § 102.13, NRCS Sediment Basin 350 and Pond 378)	44
3.12	Impoundment Dewatering (NRCS Sediment Basin 350)	44
3.13	Improving Impoundment Efficiency	45
3.14	Chemical Flocculation	46
3.15	Moat Impoundments	47
3.16	Impoundment Removal	48
3.17	Liners (Impoundment and Storage Area) (25 Pa. Code §§ 91.34 and 91.35)	48
3.17.1	Requirements for Liners	49
3.17.2	Types of Liners (Liner Materials)	49
3.17.3	Minimum Liner Requirements	49
3.17.4	Quality Assurance and Testing For Liners	52
3.17.5	Operation and Maintenance for Lined Impoundments	52
4.0	Haul Roads (25 Pa. Code §§ 77.631, 77.632, 87.80, 87.160, 88.60)	53
4.1	Haul Road Construction	53
4.2	Location and Cross - section	53
4.3	Culverts	54
4.4	Permit Application	55
4.5	Certification (25 Pa. Code § 87.160)	55
4.6	Public Highway Access (25 Pa. Code § 86.102)	55
4.7	Rock Construction Entrance	56
5.0	Discharge Effluent Requirements	57
5.1	Discharge Effluent Standards (25 Pa. Code § 92a.12)	58
5.1.1	Coal Mining Discharges	58
5.1.2	Noncoal Mining Discharges	59
5.1.3	Types of Discharges	61
5.1.4	Water Quality Based Effluent Limits (WQBELs)	62
5.1.5	Effluent Characterization	64
5.1.6	Reasonable Potential Analysis	65
5.1.7	Total Maximum Daily Load (TMDL)	65
5.1.8	Manganese	66
5.2	Antidegradation Analysis	67
5.2.1	Antidegradation Analysis	68
5.2.2	Non-Discharge Alternatives Evaluation	68
5.2.3	Discharges from Emergency Spillways	70

FOR DISCUSSION PURPOSES ONLY (AGGREGATE ADVISORY BOARD)

5.3	Point Source Discharges ABACT and SEJ Analysis in Special Protection Watersheds	70
5.4	Infiltration – Galleries or Land Application	74
5.4.1	Site Evaluation and Soil Infiltration Testing	74
5.4.2	Surface Infiltration Systems.....	75
5.4.3	Subsurface Infiltration Systems	77
5.4.4	Typical Sample Calculation: Absorption Area Sizing For Sediment Ponds and Treatment Facilities.....	80
6.0	Mine Drainage Treatment – Active Mining.....	82
6.1	General Requirements (25 Pa. Code §§ 77.526, 87.101, 87.102, 87.107, 88.91, 88.92, 88.97)	82
6.2	Treatment Processes and Reagent Selection.....	82
6.2.1	Alkaline Mine Drainage.....	82
6.2.2	Acid Mine Drainage.....	83
6.2.3	Calcium versus Sodium	83
6.2.4	Carbonate versus Hydroxide.....	84
6.2.5	Hydrated Lime	84
6.2.6	Crushed Limestone	85
6.2.7	Quicklime.....	85
6.2.8	Caustic Soda.....	85
6.2.9	Soda Ash	86
6.2.10	Reagent Selection.....	86
6.2.11	Aeration and Oxidation.....	87
6.2.12	Settling	87
6.2.13	Flocculation.....	88
6.2.14	Sludge	88
6.2.15	Suspended Solids	88
6.3	Effluent Standards.....	88
6.4	Treatment Basin Design.....	89
6.5	Example of a Treatment Basin Volume Calculation	91
7.0	Passive Treatment	92
7.1	Passive Treatment Systems.....	92
7.1.1	Net-Alkaline Passive Treatment Systems.....	92
7.1.2	Net-Acidic Passive Treatment Systems	95
7.1.3	Anoxic Limestone Drain (ALD).....	95
7.1.4	Vertical Flow Ponds (VFP)/Limestone Beds (LB).....	97
7.1.5	Planned Maintenance Systems (PMS).....	101
7.1.6	Ramped Limestone Beds (RLB).....	101
7.2	Best Management Practices for Passive Treatment Design.....	103
7.3	Design and Water Quality Criteria for Passive Treatment	107
8.0	Streams and Wetlands.....	110
8.1	Mining Activities within 100 Feet of a Stream (25 Pa. Code §§ 77.504, 86.102).....	110
8.1.1	Stream Barrier Areas (25 Pa. Code §§ 77.504, 86.102)	111
8.2	Stream Crossings (25 Pa. Code §§ 77.459, 77.523, 87.71, and Chapter 105).....	111
8.2.1	Culverts and Bridges/Water Obstruction and Encroachment Permit (25 Pa. Code § 86.102(12)).....	111
8.2.3	Culvert/Bridges/Permit Application Requirements (25 Pa. Code § 105.152)	113

FOR DISCUSSION PURPOSES ONLY (AGGREGATE ADVISORY BOARD)

8.3	Existing Stream Crossings (25 Pa. Code §§ 87.63, 88.43)	114
8.4	Temporary Road Crossings (32 P.S. § 693.7 and 25 Pa. Code § 105.441)	114
8.5	Stream Reconstruction and Channel Changes (25 Pa. Code §§ 87.104, 88.94, 88.189, 88.294, 105.221, 105.231)	115
8.5.1	Pennsylvania Fish and Boat Commission Guidelines for Stream Relocations	115
8.5.2	Importance of Pre-Application Process with Streams	117
8.5.3	Stream Impacts: Avoid, Minimize, Mitigate	117
8.6	Mining and Wetlands (25 Pa. Code Chapter 105)	118
8.6.1	Importance of Pre-Application Process with Wetlands	119
8.6.2	Avoid, Minimize, Mitigate	119
8.6.3	Protected Wetlands	120
8.6.4	Streams and Wetlands (Application Section)	120
8.6.5	Replacement Wetlands	120
9.0	Mining Near Public Roads (25 Pa. Code §§ 77.504, 86.102, 87.78, 88.57)	121
9.1	Permitting Requirements	121
9.2	PennDOT Roads	121
9.3	Township Roads	122
9.4	Common Use Roads (25 Pa. Code §§ 77.1, 77.633, 88.1, 88.150, 88.243, 88.347)	123
10.0	Slope Stability	124
10.1	Regulations	124
10.2	Stability Analysis	124
11.0	Air Pollution Control Plan	127
11.1	Processing Facilities	127
11.2	Fugitive Dust Control	127
References		128

1.0 INTRODUCTION

The Department of Environmental Protection (the Department) issues permits as authorized by various State laws and regulations for anthracite and bituminous coal mining activities, and noncoal (industrial mineral) mining activities. In addition to mining, the Department issues permits for each operation that involve a broad range of program areas, including air quality, water quality, and solid waste management. The permit process allows for input from the public, local municipalities, and other state and federal agencies. The permit application procedure provides the necessary information for the Department to make a permitting decision.

This guidance document provides assistance in the areas that surface mining permit applications involve engineering, such as the Erosion and Sediment Control Plan, water treatment plans, the air pollution control plan, stream encroachments, wetlands, haul roads, culverts, effluent requirements, special protection watersheds, and areas where mining is restricted. While the permit applications for each type of mining activity are specific as to what information is required, this guidance document explains acceptable design methods and suitable variations. This guidance document is intended for the use of mine operators, consultants, and Department staff.

District Mining Operations offices are located in Ebensburg (Cambria County), Knox (Clarion County), Moshannon (Centre County), New Stanton (Westmoreland County) and Pottsville (Schuylkill County). The District Mining Operations offices at Cambria, Knox, Moshannon, and New Stanton handle bituminous coal surface mining activities, and noncoal (industrial minerals/surface and underground) mining activities. The Pottsville District Mining Office handles all anthracite coal-mining activities and all industrial minerals operations in eastern Pennsylvania.

The Bureau of Mining Programs (Central Office) located in Harrisburg (Dauphin County) provides support to the District Mining Offices with the interpretation of mining regulations and policy. The Bureau of Mine Safety is responsible for the health and safety program for underground mines and has offices in New Stanton and Pottsville.

This manual is intended to provide guidance to applicants preparing surface permit applications, as well as to Department personnel who review the permit applications. This manual is not intended to cover all circumstances and situations that may arise in the preparation of a permit application and design of various structures associated with surface mining operations, and in no way is intended to create binding legal requirements. These legal requirements are set forth in the various statutes and Department regulations. This manual may assist the Department and the regulated community in implementing and satisfying those requirements. References to regulations in the manual are for the convenience of the reader and may not be a comprehensive list of all applicable requirements.

This manual was developed from statutes, regulations and accepted practices in the engineering field and the mining industry. Selected sections from the following Department manuals, technical guidance “Chapter 102 Erosion and Sediment Pollution Control Program Manual” (363-2134-008), the PA Stormwater Best Management Practices, the Water Quality Antidegradation Implementation Guidance, and the Land Application of Treated Wastewater

FOR DISCUSSION PURPOSES ONLY (AGGREGATE ADVISORY BOARD)

Manual may also be consulted when completing mining applications. These guidelines are available from the Department's main website.

1.1 Acronyms

AASHTO	American Association of State Highway and Transportation
ABACT	Antidegradation Best Available Combination of Technologies
ALD	Anoxic Limestone Drain(s)
AMD	Acid Mine Drainage
BAT	Best Available Technology
BMP	Best Management Practices
CWA	Clean Water Act (also known as the Federal Water Pollution Control Act)
E&S	Erosion and Sedimentation
ELG	Effluent Limit Guidelines
EPA	Environmental Protection Agency
EV	Exceptional Value Waters or Wetlands
GPS	Global Positioning System
HQ	High Quality Waters or Wetlands
LA	Load Allocation
LB	Limestone Bed(s)
MRB	Manganese Removal Bed(s)
MSHA	Federal Mine Safety and Health Administration
MUSLE	Modified Universal Soil Loss Equation
NOAA	National Oceanic and Atmospheric Administration
Noncoal SMCRA	Noncoal Surface Mining Conservation and Reclamation Act
NPDES	National Pollutant Discharge Elimination System
NSSGA	National Stone, Sand and Gravel Association
NRCS	Natural Resources Conservation Service
O&M Plan	Operation and Maintenance Plan
PA SMCRA	Pennsylvania Surface Mining Conservation and Reclamation Act
PASPGP	Pennsylvania State Programmatic General Permit
PennDOT	Pennsylvania Department of Transportation
PENTOX	Pennsylvania Single Wasteload Allocation Program for Toxics and Other Substances
PFBC	Pennsylvania Fish and Boat Commission
PFDA	Precipitation Frequency Data Server
PGC	Pennsylvania Game Commission
PLAP	Pennsylvania Laboratory Accreditation Program
PMS	Planned Maintenance System(s)
RLB	Ramped Limestone Bed(s)
RPA	Reasonable Potential Analysis
RUSLE	Revised Universal Soil Loss Equation
SEJ	Social or Economic Justification
SMCRA	Federal Surface Mining Conservation and Reclamation Act
TMDL	Total Maximum Daily Load
TSF	Trout Stocked Fisheries
TSS	Total Suspended Solids

FOR DISCUSSION PURPOSES ONLY (AGGREGATE ADVISORY BOARD)

UIC	Underground Injection Control Permit
USACE	United States Army Corps of Engineers
USGS	United States Geological Survey
USLE	Universal Soil Loss Equation
VFP	Vertical Flow Pond(s)
WLA	Waste Load Allocations
WQAIG	Water Quality Antidegradation Implementation
WQBELs	Water Quality Based Effluent Limits
WWF	Warm Water Fisheries

DRAFT

2.0 EROSION AND SEDIMENTATION CONTROL

Many of the practices described in this section may differ from practices described in the Department's Chapter 102 manual. Both the surface coal mining regulations at 25 Pa. Code § 87.112(b) and non-coal regulations at § 77.531 refer to two different standards relative to erosion and sedimentation controls, specifically Chapter 102 and the Soil Conservation Service Engineering Standard No. 350. Title 25 Pa. Code § 87.108(d) and § 77.569 set the requirements of Chapter 102 as the minimum standard. Recognizing that surface mines tend to have longer lifespans and large areas of exposed soils, more appropriate standards specific to mining activities are frequently warranted. Because of the need for uniformity in mining permit applications and to make the Department's requirement clear and predictable, this chapter was developed as a guide for erosion and sedimentation controls on mining operations. It does not apply to other activities requiring a Chapter 102 permit such as land development and construction activities.

In surface mining, water generated erosion is the most severe type of erosion (as opposed to wind, ice and gravity) acting on large areas of soil, subsoil, and overburden exposed during mining activities. Water erosion is a process in which raindrops and flowing water act to detach soil particles or materials and transport them across the surface of the land. Water erosion is the type of erosion that is the focus of this manual and will be referred to as "erosion" in the remainder of this manual.

Undisturbed soils resist erosion in several ways:

- Vegetation serves to protect the land from the physical impact of raindrops.
- Root development forms an interwoven mesh that prevents soil particles from moving.
- Clay particles and organic matter exhibit cohesive forces, which hold larger, non-cohesive silt- and sand-sized particles together to form soil aggregates.
- Larger particles and aggregates are more resistant to erosion due to their size and weight.

Undisturbed soils typically exhibit higher infiltration rates than compacted soils. Therefore, the amount of runoff per unit area will be less for undisturbed soils than for compacted soils. Mining activities have a significant impact on reducing soil aggregation and soil structure and increase the potential for erosion.

2.1 Different Types of Erosion

Undisturbed and disturbed watersheds can experience any or all of the following types of erosion:

- Raindrop Erosion
- Sheet Erosion
- Rill Erosion

- Gully Erosion
- Channel Erosion

2.1.1 *Raindrop Erosion*

Erosion from rainfall begins when raindrops impact the ground, dislodge soil particles, and splash them into the air. The splashed particles may reach a height of 3.0 feet and cover a radius of as much as 5.0 feet. Gray (1982) reported raindrop velocities of approximately 20.0 miles per hour during cloudbursts. Mulching the area prone to erosion helps to absorb raindrop impact energy and is very effective in protecting the soil (Beasley et al. 1984).

2.1.2 *Sheet Erosion*

Sheet erosion occurs when runoff manifests as a thin sheet of flowing water. This occurs over uniformly sloped areas and is discernible only upon close examination. Surface Irregularities typically reduce effective distance of sheet erosion to less than 30 feet before flow becomes concentrated. Sheet erosion transports the soil particles detached due to the impact of rainfall.

Sheet erosion decreases over time as the smaller particles are transported away, leaving a coarser, more erosion resistant soil. This process of erosion of the finer soil particles is referred to as *armoring*. Sheet erosion can be greatly reduced through expeditious establishment of vegetation, by seeding and immediately mulching. Highly erodible soils may require erosion control blanketing in addition to seeding and mulching to prevent sheet erosion until the vegetation is established. Soils that are highly erodible, on steep slopes, or in environmentally sensitive areas may require temporary soil binding agents. Sheet erosion, though less visible than other types of erosion, is the dominant erosion process that takes place early on a reclaimed mine site.

2.1.3 *Rill Erosion*

Rill erosion occurs as runoff concentrates in small channels and the shearing force of flowing water detaches additional soil particles. Rill erosion is characterized by uniform spacing of eroded parallel channels (or rills) that are discernible both close up and at a distance. It is most noticeable on bare, recently graded, or newly seeded soils. Rills can be removed with normal agricultural tillage equipment and controlled by the establishment of soil cover, seeding parallel to the contours, adequate mulching, use of erosion control blanketing, use of soil binders, and proper spacing of terraces or benches. The use of terraces and benches reduces the steeper slope lengths in the overland flow path for runoff.

2.1.4 *Gully Erosion*

As the small rivulets apparent in rill erosion combine to form larger channels, the erosive force of the water increases, and gully erosion occurs. Gully erosion leaves deep, defined channels that cannot be removed by agricultural tillage equipment. These channels will continue to grow to greater depths until an erosion-resistant layer is encountered in the backfill or natural soil horizon. Gully erosion can be controlled by the design and construction of adequate diversion channels above the affected area to divert runoff on steeper can be controlled by the regrading, reseeding and blanketing of erosion-prone areas.

When previously regraded and planted post-mining land is affected by rill or gully erosion, the erosional feature(s) must be filled, graded, or otherwise stabilized and the area reseeded or replanted. The regrading or stabilization of a rill or gully should be completed by the first normal period for favorable reseeding or replanting. A rill or gully contributing to impacts outside the permit area, or a rill or gully occurring after removal of erosion and sediment control Best Management Practices (BMPs) should be stabilized immediately.

2.1.5 *Channel Erosion*

The last level of erosion is channel erosion, which occurs when gully erosion progresses into channel erosion. Previously stable streams that have adapted to a particular peak rate and volume of runoff can become unstable as the prevailing peak rate and/or volume of runoff increases in reaction to changes in runoff amounts within the upstream watershed. This instability is due to inadequate hydraulic capacity for the increased volume of runoff generated and inadequate bed and bank linings for the higher velocities encountered. The size and quantity of material that can be eroded and transported increases as the velocity and volume of runoff increase.

Channel erosion is reduced by decreasing the volume and peak rate of runoff leaving a site. This can be achieved by preserving existing flow paths and vegetative cover where ever possible, maximizing use of evapotranspiration in post-mining conditions, minimizing soil compaction, improving soil cover, reducing slope lengths, energy dissipation, and increasing the time of concentration or retention of the water leaving the site.

Gully and channel erosion can have a significant impact for many years after reclamation has been completed. On the other hand, the primary impact of sheet and rill erosion is through significant contributions of sedimentation immediately after reclamation.

2.2 **Regulations**

The statutory authority for erosion and sediment control related to mining activities include the Pennsylvania Clean Streams Law, the federal Surface Mining Control and Reclamation Act (SMCRA), the Pennsylvania Surface Mining Conservation and

FOR DISCUSSION PURPOSES ONLY (AGGREGATE ADVISORY BOARD)

Reclamation Act (PA SMCRA) and the Pennsylvania Noncoal Surface Mining Conservation and Reclamation Act (Noncoal SMCRA). The regulatory requirements for erosion and sediment related items are contained in 25 Pa. Code Chapter 77 (Noncoal Mining); Chapter 86 (Surface and Underground Coal Mining: General); Chapter 87 (Surface Mining of Coal); and Chapter 88 (Anthracite Coal Mining).

The Department also administers the Chapter 102 erosion control regulations, with which Chapters 77, 86-88 require compliance. The Department's eLibrary contains technical guidance document "Chapter 102 Erosion and Sediment Pollution Control Program Manual" (363-2134-008), that explains in detail many of the erosion and sediment control measures discussed in this manual. This manual cites, where appropriate, sections of the Erosion and Sediment Pollution Control Manual.

Another useful resource is the Natural Resources Conservation Service's (NRCS) eDirectives website, which covers many areas of erosion, and sediment control design, including estimating runoff, hydraulics, soils, grassed waterways, diversions, culverts and impoundments. The website can be found at: <http://directives.sc.egov.usda.gov/>.

Enter "Engineering Field Manual" in the search box for the most recent version.

Department mining regulations reference NRCS Practice Standards, Sediment Basin 350 and Pond 378 and these apply to all mining-related erosion and sedimentation and treatment impoundments. Sediment Basin 350 applies to temporary erosion and sedimentation basins whose expected life is five years or less. These two publications are part of the NRCS's PA Field Office Technical Guide.

Title 25 Pa. Code Chapter 77 (Noncoal Mining) references both Chapter 102, and its accompanying Erosion and Sediment Control Manual and the NRCS's Sediment Basin 350. Noncoal mining regulations cover activities such as sand and gravel, bluestone, rock pits for oil and gas operations, sandstone, and limestone mining. Each type of mining has accepted types of controls associated with it, ranging from sediment traps for internally drained sand and gravel operations to oversized sediment basins with non-discharge alternatives for hard rock mining on special protection watersheds. The Department recommends that a pre-application should be filed for each noncoal mine to discuss the Erosion and Sedimentation Control Plan (E&SCP) controls before the formal application is filed.

2.2.1 Sediment Pollution

Sediment pollution is the placement, discharge or other introduction of soil particles into the waters of the Commonwealth. Sediment pollution occurs as a result of either failing to design, construct, implement, or maintain control measures and control facilities in accordance with the Department's regulations, or causing the movement of soil particles in a manner that is harmful, detrimental, or injurious to the designated uses of the waters of the Commonwealth.

Sediment that is deposited on stream bottoms is detrimental to the stream's micro-invertebrates and invertebrate's communities. Particles that remain

suspended are often angular and will cut and abrade gill structures of fish, causing disease and mortality. Sediment from earth disturbance activities, such as mining operations, frequently contains high clay content. The clay-sized particles are difficult to settle out and can result in higher stream turbidity. High turbidity can present problems for water withdrawn for a public water supply.

When the velocity of water transporting sediment falls below the point necessary to hold the material in suspension, the sediment begins to be deposited. The particles drop out in order of size: first gravel, then sand, then silt, and finally the smaller clay-sized particles. Particles that settle to the bottom of a stream effectively fill the voids in the substrate and can smother macroinvertebrate communities. The cumulative effect of mining operations in a watershed can result in a significant increase in the sediment load and the potential destruction of downstream aquatic habitat.

2.3 Erosion and Sedimentation Control Plan (E&SCP) (25 Pa. Code §§ 77.525, 87.70, 87.106, 88.50, 89.21, 90.37, 90.106, 102.4)

An Erosion and Sedimentation Control Plan (E&SCP) is required as part of the mining permit application. The proposed sediment control measures for mining and reclamation must meet the Department requirements. The E&SCP serves as the operator's blueprint for installing sediment control measures in the permit application. It is the means to demonstrate the adequacy of sediment control measures that will be implemented. The E&SCP must cover all areas to be disturbed by the mining operation within the proposed permit area during all stages of mining and reclamation. Further, the reclamation is successful when revegetation permanently stabilizes the area against accelerated erosion.

The E&SCP should address the erosion and sediment control measures that will be used from the time of initial disturbance of the area until successful revegetation is achieved. All areas that will be disturbed or affected by the operation, including haul roads, storage areas and support areas, must be part of the plan.

The E&SCP must meet the requirements of 25 Pa. Code § 102.4, and should include information such as the type, depth, slope, locations, limitations, and areal extent of the soils found in the permit area. The regulations also require the E&SCP provide BMPs to minimize the potential for accelerated erosion and sedimentation and to manage stormwater after mining is concluded. Section 102.2 requires that the BMPs utilized must protect, maintain, reclaim and restore water quality and the existing and designated uses of waters of the Commonwealth.

Soil information can be found on the NRCS website:
<http://websoilsurvey.nrcs.usda.gov/app/WebSoilSurvey.aspx>.

The soil reports are a source of information that can be used to determine soil properties. The E&SCP must contain a narrative describing the implementation of the plan, detailed design and construction plans, and specifications for each structure or facility used in the plan.

For mining activities, the design of the E&SCP must be prepared by, or under the direct supervision of a qualified professional engineer or qualified land surveyor registered under the Pennsylvania State Registration Board for Professional Engineers, Land Surveyors and Geologists.

The E&SCP must not result in an adverse effect on downstream culverts and drainage channels. This is especially important if the erosion and sedimentation control facilities will divert drainage from one sub-watershed area to another, causing existing culverts or channels to be overloaded. It is also important to document the condition and capacity of the existing drainage system before affecting a site so that it can be established after reclamation that mining did not have an adverse effect.

For any revisions to the original E&SCP, the revised pages of the mine permit application, including the narrative, must indicate the page number and date of revision. If revisions extend beyond limitations of the original page, the revision should bear the original page number and sequential letter of the alphabet.

2.4 Control Measures That Reduce Erosion and Sedimentation (25 Pa. Code §§ 77.525, 87.70, 87.106, 88.50, 89.21, 90.37, 90.106, 102.4)

Erosion control practices are designed to prevent the detachment of soil particles, whereas sediment control practices are used to prevent the detached particles from leaving the site and entering the receiving waterways. Erosion and sedimentation can be controlled at a mining operation by proper planning and the use of erosion and sedimentation controls. Those relevant to mining activities include the following:

2.4.1 Limiting Exposed Area

The affected mineral removal area should be limited to what is needed in the near future. Expose the area for the shortest period of time. Backfilling must be concurrent with mining, and the topsoil must be redistributed and seeded during the first favorable planting season. All these practices, besides reducing erosion and sedimentation, will reduce the amount of pit water to be pumped and treated, limit the amount of bond on the site and allow for a quicker release of the posted bond(s).

2.4.2 Surface Water Diversion

All surface water should be diverted away from the active mining area. This typically means an upslope diversion channel, which will outlet away from the mining area in a safe, non-erosive manner.

2.4.3 Velocity Control

Designing channels for the lowest possible velocity is an important method of reducing erosion. All channels and watercourses shall be designed and stabilized to withstand anticipated flow velocities and to convey peak flows without deterioration of the channel. Channels, pond inlets, and outlets shall be armored

with properly sized rock. Table 2.1: Quarried Stone for Erosion and Sediment Control/National Stone, Sand and Gravel Association (NSSGA) can be used to select the appropriate size riprap.

DRAFT

**Table 2.1: Quarried Stone for Erosion and Sediment Control/
National Stone, Sand and Gravel Association⁽⁵⁾**

Quarried Stone for Erosion and Sediment Control						
Graded Rip-Rap Stone						
NSSGA No.	Size inches (square opening)			Wave Height ⁽³⁾	Velocity ⁽⁴⁾	Filter Stone
	Max.	Avg. ⁽¹⁾	Min ⁽²⁾	feet	feet/sec	NSSGA Size No.
R-1	1½	¾	No. 8	-	2.5	FS-1
R-2	3	1½	1	0.3	4.5	FS-1
R-3	5	3	2	0.5	6.5	FS-2
R-4	12	6	3	1.0	9.0	FS-2
R-5	18	9	5	1.5	11.5	FS-2
R-6	24	12	7	2.0	13.0	FS-3
R-7	30	15	12	2.5	14.0	FS-3
R-8	48	24	15	4.0	-	FS-3

Armor Stone ^(*)					
NSSGA No.	Wt. in Short Tons			Wave Height (feet) ⁽⁶⁾	Filter Stone
	Max.	Avg. ⁽¹⁾	Min ⁽²⁾		
A-1	4.0	3.0	2.0	8.0	See Supplemental Engineering Notes.
A-2	6.0	4.5	3.0	10.0	
A-3	8.0	6.5	5.0	12.0	

(*) one or more under layers may be required in addition to filter stone

Filter Stone			
Size inches (square opening)			
NSSGA No.	Max.	Avg.	Min. ⁽²⁾
FS-1	3/8	No. 30	No. 100
FS-2	2.0	No. 4	No. 100
FS-3	6½	2.5	No. 16

Notes:

- (1) "Average size" is that size exceeded by at least 50 percent of the total weight of the tonnage shipped; i.e., 50 percent of the tonnage shall consist of pieces larger than the "average" size (normally 1/2 the specified nominal top/maximum size).
- (2) Pieces smaller than the minimum size shown shall not exceed 15 percent of the tonnage shipped.
- (3) Wave Height is the vertical distance from wave crest to wave trough. The wave height given in the table is the average height of the one-third highest waves in the incident wave train.
- (4) The stream velocity is the velocity at mid-stream or at a point 10 feet from the bank, whichever is closest to the bank.
- (5) The Table assumes a stone dry density of 165 pounds per cubic feet.
- (6) The stone industry generally is unable to produce economically armor stone in sizes to fit the 6-foot wave height category. Therefore, the reader should use NSSGA No. A-1.

Flow velocities in watercourses leaving the completed mining area shall be less than those calculated to initiate or accelerate erosion or scour within the receiving watercourses.

2.4.4 *Permanent Stabilization*

All slopes, watercourses, or disturbed areas should be permanently stabilized as soon as possible after mining has been completed. This requires concurrent backfilling, placement of top soil, and planting and mulching.

2.4.5 *Temporary Stabilization*

Until a disturbed area is permanently stabilized, the erosion and sediment pollution control measures and control facilities should be maintained, or interim stabilization measures should be installed, to minimize accelerated erosion and prevent sediment pollution.

2.4.6 *Collection of Runoff*

Runoff from an earth disturbance area should be conveyed to control measures or control facilities for removal of sediment.

2.4.7 *Sediment Pollution Control*

Runoff from the earth disturbance area should pass through a control measure or control facility, including, but not limited to, sediment basins, sediment traps, filter areas and onsite erosion controls to prevent sediment pollution.

2.4.9 *Perimeter Controls*

Erosion and sediment controls should be installed along the perimeter to prevent the sediment from leaving the site. These controls should be installed before disturbing the area, and the controls should be maintained to ensure that they function properly.

2.4.10 *Infiltration*

The process of handling soils by removing the topsoil and subsoils, their storage for long periods, and replacing them on a site for revegetation has an impact on the infiltration capacity the soil. Water and air infiltrate soils through void spaces present within the soil. Compaction of the soil by repeated passage of heavy equipment reduces the void spaces and decreases the amount of water and air that can infiltrate into the soil.

The degree of compaction of a reclaimed soil is controlled by the water content of the soil when it is handled and by the ground pressure and number of passes of the equipment used in removing and replacing the topsoil. When a high level of compaction is necessary, water is added to the soils to bring the moisture content up to "optimum moisture" which adds cohesiveness to the soils. The natural moisture content of stockpiled soil changes, and when replaced and regraded, has a significant impact on the density and compaction of the reclaimed soil. To

avoid excessive compaction, soil should not be handled during or immediately after wet periods. Care should be taken to minimize the repeated passage of equipment over the soil during the soil removal and replacement operations. The use of wide track dozers, rather than (scrapers), to remove and replace soil will generally result in less compaction of the soil. The use of such equipment is necessary when prime farmland soils or other high productivity soils are involved.

In order to allow air and water to reach the soil, the voids within a soil must be interconnected. Not all void spaces within a soil are effective in allowing air and water to infiltrate the soil. These interconnected voids are the result of decaying plant matter, earthworms, insect, animals (moles, mice, voles, etc.), frost action, and weathering of the soil over time. Compaction destroys the interconnected voids. While cultivation practices, such as plowing or discing, can increase the voids in a soil, the effective or interconnected voids will need time to reestablish.

Equipment used to move the soil have a significant effect on compaction. In general, the physical removal of the soil by loaders and trucks is less likely to cause compaction than the use of pans (scrapers). Bulldozers used for topsoil handling also cause less compaction than scrapers due to a lighter loading per unit area for bulldozers than for wheeled equipment. Maintaining the soil voids will increase the infiltration capacity. This is important since a decrease in infiltration will increase the amount of runoff and accelerate erosion and sedimentation problems.

Infiltration capacity varies by soil type across the state. Permeability rates are listed for each soil on the Natural Resources Conservation Service (NRCS) website: <http://websoilsurvey.nrcs.usda.gov/app/WebSoilSurvey.aspx>.

2.5 Hydrology

Hydrology is utilized to determine expected peak discharges and runoff volumes for different frequency storm events. This information is required to design channels, impoundments, stream relocations, or stream crossings.

The NRCS has developed procedures for determining both the volume of runoff and peak rates of runoff for small watersheds across the United States. The NRCS hydrology methods are easy to apply and are the most common hydrology methods used on mining permit applications. These methods are based on anticipated rainfall amounts for various frequency 24-hour rainfall events and data collected for different soils and types of cover, which is represented as a curve number. A simplified procedure is found in Chapter 2 of the NRCS's Engineering Field Manual. A slightly more involved procedure is utilized in the NRCS Urban Hydrology for Small Watersheds - Technical Release No. 55 (June/1986). The publications differ only in the assumptions used in obtaining the time of concentration.

Many software programs available can be used to calculate peak discharges and runoff volumes. The results obtained from these programs should closely agree with the values obtained by using the NRCS methods.

The majority of all of the Department's requirements are based on 24-hour rainfall events. The Bureau of District Mining Operations accepts and recommends the use of the NRCS hydrology methods for permit applications. The 24-hour rainfall totals for various rainfall events can be found at NOAA's National Weather Service, Hydrometeorological Design Studies, Precipitation Frequency Data Server (PFDA) (<http://hdsc.nws.noaa.gov/hdsc/pfds>). Coal mining operations should use Title 25, § 87.103 and § 88.93, "Precipitation Event Exemption" for a 10-year, 24-hour storm event.

2.6 Channels

2.6.1 *Upslope and Highwall Diversion Channels (25 Pa. Code §§ 77.524, 87.105, 88.95, 102.12)*

Surface water and shallow groundwater from upslope undisturbed areas that would drain across the mining area into the affected area must be intercepted and directed away from the disturbed area. This is done by the use of upslope diversion channels. Upslope diversion channels not only minimize the amount of water that contributes to the erosion and sedimentation process, but also minimize the amount of water that must be routed to a sedimentation pond or other controls. Highwall diversion channels should be constructed immediately above all highwalls where practical to minimize the volume of water that could be contaminated in the pit and would need to be pumped to the treatment facilities.

Any water collected in a diversion channel is to be considered "clean" and must be protected against any runoff from affected, disturbed areas. All such channels must outlet via a stable structure to a natural drainageway.

2.6.2 *Diversion Channel Design Considerations*

The diversion channel should be located as close as possible to the upslope boundary of the disturbed area and extend downslope for the entire length of the disturbed area. The diversion channel must provide positive drainage over the entire length of the disturbed area, and the outflow from the diversion must be discharged in a manner that will not cause erosion. Diversion channels that exit above previously mined areas should be continued across the mined area. The outlet for diversion channels should be a rock-lined energy dissipater, a level spreader, or a stable existing drainageway.

Diversion channels are generally triangular, trapezoidal, or parabolic in cross-section. Excavated material should be placed downslope of the diversion to provide additional freeboard against overtopping. Generally, calculations of open channel capacity and flow velocity are performed using the Manning's equation:

$$Q = \frac{1.486}{n} * a * r^{2/3} * s^{1/2} \quad \text{and} \quad V = \frac{1.486}{n} * r^{2/3} * s^{1/2}$$

Q = flow rate

V = velocity
a = cross - sectional area of channel
r = A/P (hydraulic radius of channel = area/wetted perimeter)
s = channel slope (percent)
n = Manning's Roughness Coefficient

("Chapter 102 Erosion and Sediment Pollution Control Program Manual"
(363-2134-008), p. 128)

The appropriate Manning's "n" value (roughness coefficient), should be used for the different channel linings. Runoff from small areas can be discharged by the use of an energy dissipater and a level spreader, which spreads the concentrated channel flow into sheet flow. A sediment trap should be used when the flow would outlet onto a disturbed area.

Temporary diversion channels (e.g., highwall diversion channels) must have sufficient capacity to pass the two (2)-year, 24-hour storm event. Permanent diversion channels (upslope diversion channels) must have sufficient capacity for the runoff from the 10-year, 24-hour storm event. The design freeboard should be a minimum of 0.50 feet. Temporary diversion channels can be used during mining activities but may not remain after reclamation as part of the approved post-mining land use. Permanent diversion channels are designed to remain in place for years after surface coal mining activities are completed.

As the total length of a diversion channel and the area draining to it increases, the potential for breakouts and accelerated erosion increases. To ensure proper construction, diversion channels should be surveyed and staked in the field prior to construction. The minimum preferred slope for a diversion channel is from one (1) to two (2) percent to allow ease of construction in the field.

A suitable protective liner must be provided for each diversion channel (see Table 2.1). When the diversion channel slope varies or the discharge changes significantly, each segment of the channel must be designed to meet those conditions.

Specific design criteria for capacity and stability shall adhere to the requirements of Chapter 6 of the Department's guidance document "Chapter 102 Erosion and Sediment Pollution Control Program Manual" (363-2134-008).

2.6.3 *Collection Channels (25 Pa. Code §§ 77.525, 87.106, 88.96, and 102.13)*

Collection channels are used to route flow from affected/disturbed mining areas to the erosion and sediment pollution controls. They are located around the boundary of the mining operation and prevent untreated runoff from leaving the site.

2.6.3.1 Collection Channel Design Considerations

The collection channel is located downslope from the disturbed area and should extend downslope for the entire length of the disturbed area. The channel must provide positive drainage and outlet to a sedimentation impoundment or other control.

The collection channel must have sufficient capacity for a 10-year, 24-hour storm event.

Freeboard is to be a minimum of 0.50 feet (Higher return-period storm events and/or increased freeboard may be required on channels that will be in place for more than five years).

As the total length of a collection channel and the area draining to it increases, the potential for breakouts and accelerated erosion continue. To ensure proper construction, collection channels should be surveyed and staked in the field prior to construction. The minimum preferred slope for a collection channel is from one (1) to two (2) percent to allow ease of construction and maintenance in the field.

The collection channel must be capable of conveying peak runoff at non-erosive velocities, which may require rock lining. When the collection channel slope varies or the discharge changes significantly, each segment of the channel must be designed to meet changing field conditions. The NSSGA has published a reference publication titled "Quarried Stone for Erosion and Sediment Control" that can be used to help size riprap. The permit application should indicate the size of stone to be utilized and the installation thickness. If a percentage by weight or size is specified, the D50 rock size should be utilized. For velocities above 4.50 feet/sec, an erosion resistant lining is required. This lining can be graded riprap, jute matting, geotextile, or other Department approved material.

Whenever possible, a vegetated area should be left between the lower limit of mining area and the channel construction area. This will slow down the flow prior to entering the channel and allow sediment to filter out.

Where possible, collection channels should be combined with in-channel, rock filters as the water being conveyed in these channels will likely be high in sediment content. Rock filters will allow for more predictable settling of solids and maintenance of the channels.

2.7 **Vegetation-Lined Channels**

Due to their ease of construction and low cost, vegetation-lined channels are frequently used to line diversion and collection channels. A well-vegetated channel may be used

when the anticipated peak velocity is below 4.50 feet/sec. The vegetation should be well established before the channel begins to carry its design capacity. Any transition points, especially the inlet into the sedimentation basin should be lined with the appropriate rock or manufactured lining.

- A velocity of 3.0 feet/sec should be the maximum if only a sparse vegetative cover can be established or maintained.
- A velocity of 3.0 to 4.0 feet/sec should be used under normal conditions if the vegetation is to be established by seeding.
- A velocity of 4.0 to 4.50 feet/sec should be used only in areas where a dense, vigorous sod is obtained quickly or if water can be diverted out of the waterway while vegetation is being established.
- When base flow exists, a rock lined low flow channel should be designed and incorporated into the vegetative lined channel section.

Vegetation-lined channels typically begin eroding in the invert of the channel. Once the erosion process has started, it will continue until an erosion-resistant layer is encountered. If erosion of a channel bottom is occurring, stone should be placed in the eroded area.

2.8 Rock-Lined Channels

When the anticipated velocity increases to a point that a vegetated lining is no longer adequate, other measures such as rock linings are typically used for diversion and collection channels. Specific design criteria for capacity and stability of rock-lined channels shall adhere to the requirements in Section 2.5.3 “Velocity Control” of this document. Rock-lined channels are designed using the wetted perimeter, as illustrated in Figure 2.1 (Channel Cross-Sectional Areas and Wetted Perimeters). A cross-section of a rock-lined channel is illustrated in Figure 2.2 (Detailed Cross-Section of a Rock Lined Channel).

Figure 2.1.
Channel Cross-Sectional Areas and Wetted Perimeters

(* Freeboard = $D - d$ for all sections.)

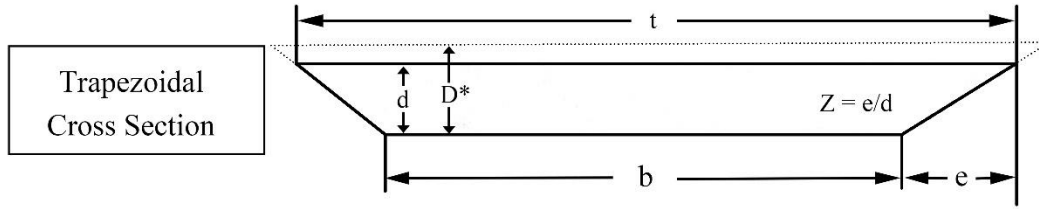

Cross Sectional Area, a	Wetted Perimeter, P	Hydraulic Radius, $R = a/P$	Top Width, t
$bd + Zd^2$	$b + 2d\sqrt{Z^2 + 1}$ or $b + 2dZ$ approx.	$\frac{(bd + Zd^2)}{b + 2d\sqrt{Z^2 + 1}}$	$b + 2dZ$

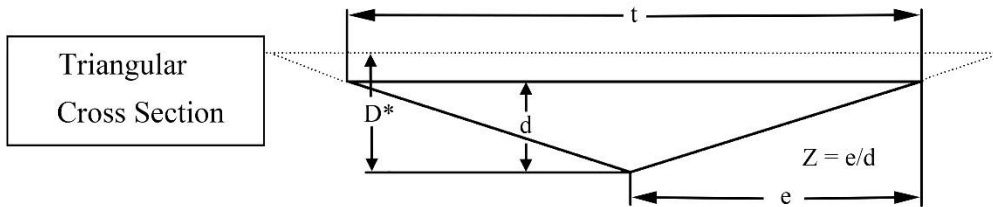

Cross Sectional Area, a	Wetted Perimeter, P	Hydraulic Radius, $R = a/P$	Top of Width, t
Zd^2	$2d\sqrt{(Z^2 + 1)}$ or $2dZ$ approx.	$\frac{Zd}{2d\sqrt{(Z^2 + 1)}}$	$2dZ$

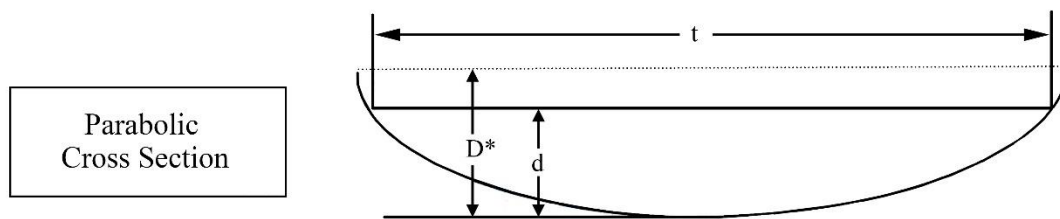

Cross Sectional Area, a	Wetted Perimeter, P	Hydraulic Radius, $R = a/P$	Top width, t
$(2/3)td$	$t + (8d^2) / (3t)$	$\frac{(t^2)d}{1.5t^2 + 4d^2}$ or $2d/3$ approx.	$a/(0.67d)$

Figure 2.1.
Channel Cross-Sectional Areas and Wetted Perimeters (continued)

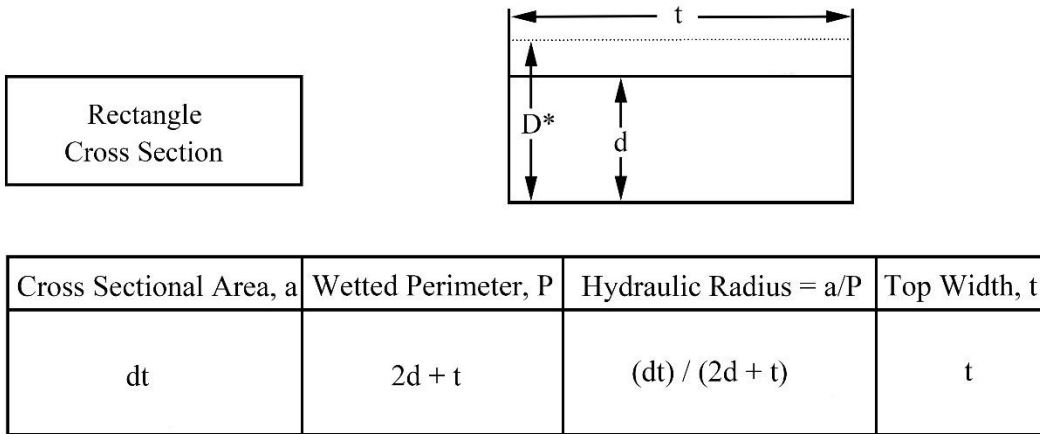
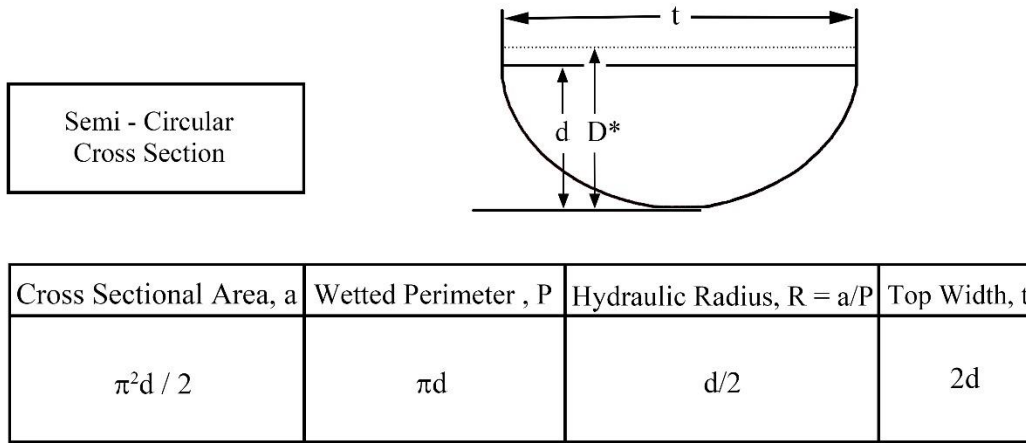
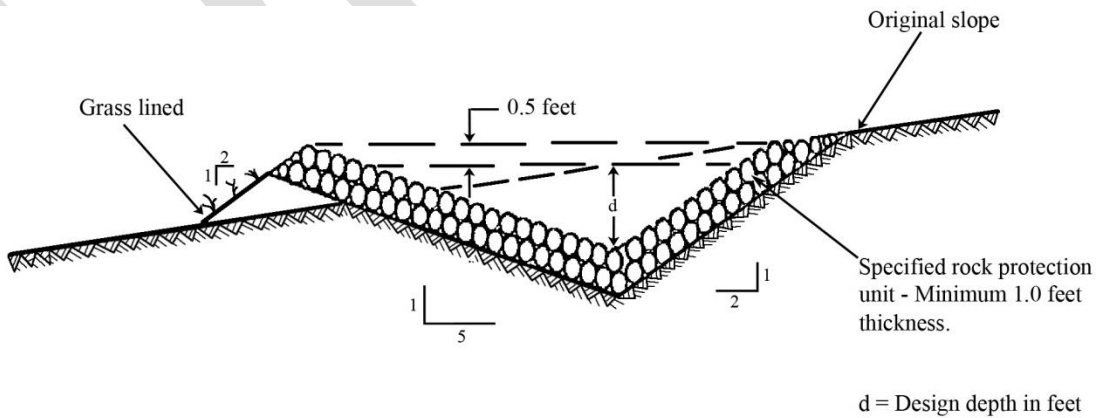

Figure 2.2.
Detailed Cross-Section of a Rock Lined Channel



Detail of Rock Riprap Protection Unit

2.8.1 Rock Filters

Rock Filters can be constructed across collection or diversion channels. Their purpose is to reduce the velocity of runoff in the channel, thereby reducing erosion of the channel. The distance between Rock Filters will vary depending on the slope of the channel, with closer spacing when the slope is steeper. The stone size used in the Rock Filters should also vary with the expected design velocity and discharge. As velocity and discharge increase, the rock size should also increase. For most Rock Filters, the NSSGA No. R-4 stone (3 inch to 12 inch, average 6 inch) is a suitable stone size. To improve the sediment trapping efficiency of Rock Filters, a filter stone can be applied to the upstream face. A well-graded coarse aggregate such as American Association of State Highway and Transportation “AASHTO No. 67” (less than 1 inch in size) can be used as a filter stone. The design of a Rock Filter is illustrated in Figures 2.3, 2.4, and 2.5.

Sediment that accumulates behind the Rock Filter should be removed when it has accumulated to one-half of the original height of the filter.

**Figure 2.3.
Rock Filters**

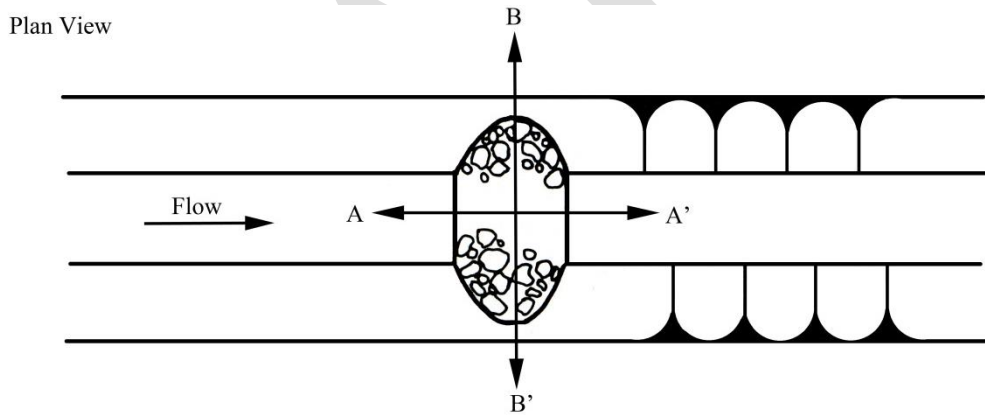

**Figure 2.4.
Rock Filters**

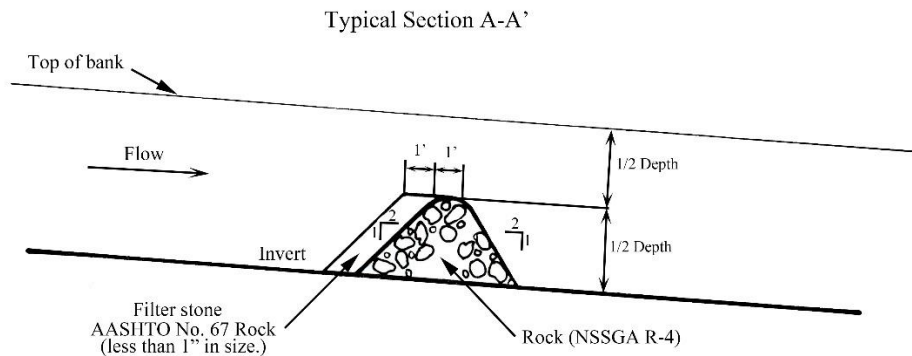
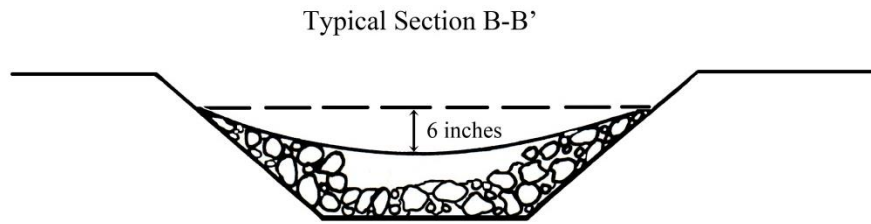

Figure 2.5.
Rock Filters



Adapted from Erosion and Sediment Pollution Control Manual (1990)

2.9 Other Erosion and Sedimentation Controls

The Department has found that channels and ponds are the most effective erosion and sedimentation control measures for mining operations, from both a cost and a functionality basis. These are considered to be conventional E&S measures. The maintenance costs associated with channels, ponds are minimal, and the measures allow discharges to meet effluent standards.

The Department will consider the use of alternative erosion and sedimentation controls when there is a justification that construction of conventional erosion and sedimentation controls not feasible and/or the drainage area is less than five acres provided the required effluent standards can be met with the proposed controls. Examples of alternate erosion and sedimentation controls include filter fences backed by straw bales, Super Silt Fence, earthen berms, Composite Filter socks, and sediment traps.

In noncoal mining, operations range from internally drained sand and gravel mines to hard rock mines with benched highwalls. The appropriate erosion and sedimentation controls will vary with the type of mining operation. In some instances, Chapter 102 BMPs may be sufficient, and in other cases (hard rock terraces on High Quality Waters), oversized ponds and channels with infiltration galleries may be appropriate.

If the erosion and sedimentation controls are not maintained properly or are unsuccessful in controlling runoff, the Department will require the submission of a revised E&SCP to correct the problem. When a situation arises for the potential use of alternate erosion and sedimentation controls, the appropriate District Mining Operations office should be consulted.

2.9.1 Silt Fence

When used properly, a silt fence or a silt fence backed with straw bales can be a moderately effective erosion and sedimentation control. A typical silt fence installation and silt fence cross-section are illustrated in Figure 2.6 and Figure 2.7. Examples of potential uses of silt fence include short-term use during construction or reclamation of erosion and sedimentation facilities, stream crossings, stream

encroachments, haul roads and as a control for small drainage areas. Depending on site-specific conditions and proposed time of use, silt fence may need to be backed by hay bales. Filter fabric fence is frequently installed in inappropriate situations, not installed properly and not given adequate maintenance. Common problems include placing silt fence in areas of concentrated flows, and/or steep slopes, and placing fence on a slope rather than along the contours. Proper installation requires burying the toe of the fence properly, and using long stakes driven at least 18 inches into the ground. The condition of the fence must be checked after every rainfall event and repairs made promptly.

When it is not feasible to construct typical erosion and sedimentation controls and silt fence is used, the Department recommends the following:

- The fence is placed at zero (0) percent grade; i.e., parallel to the contours, and follows a level alignment.
- The 30-inch high reinforced silt fence shall be designed to control runoff from drainage areas that do not exceed the maximum slope length to percent slope relationships shown in Table 2.2 (Maximum Slope Length for Silt Fence). The slope length shown is the distance from the fence to the drainage divide or nearest upslope channel.

Table 2.2: Maximum Slope Length for Silt Fence

Maximum Slope Length for Silt Fence			
Slope Percent	Maximum Slope Length (feet) Above Fence		
	Standard (18" High) Silt Fence	Reinforced (30" High) Silt Fence	Super Silt Fence
2 (or less)	150	500	1000
5	100	250	550
10	50	150	325
15	35	100	215
20	25	70	175
25	20	55	135
30	15	45	100
35	15	40	85
40	15	35	75
45	10	30	60
50	10	25	50

The installation should be constructed in undisturbed ground. Severely disturbed or mined soils are typically too rocky and erodible to obtain a good tie-in of the bottom of the silt fence. When slope lengths are too long for one silt fence installation, a second installation should not be installed in the backfilled area. In this situation, typical erosion and sedimentation control measures should be used.

The tie-in at the bottom of the silt fence is very important in preventing piping or blowouts. The bottom of the fence should not only be buried, but the filter cloth should be laid across the bottom of the trench to reduce piping underneath the trench and to prevent the fence from being pulled out of the ground. The bottom of the filter is “L” shaped when properly installed. (See Figure 2.7)

Figure 2.6.
Silt Fence Installation

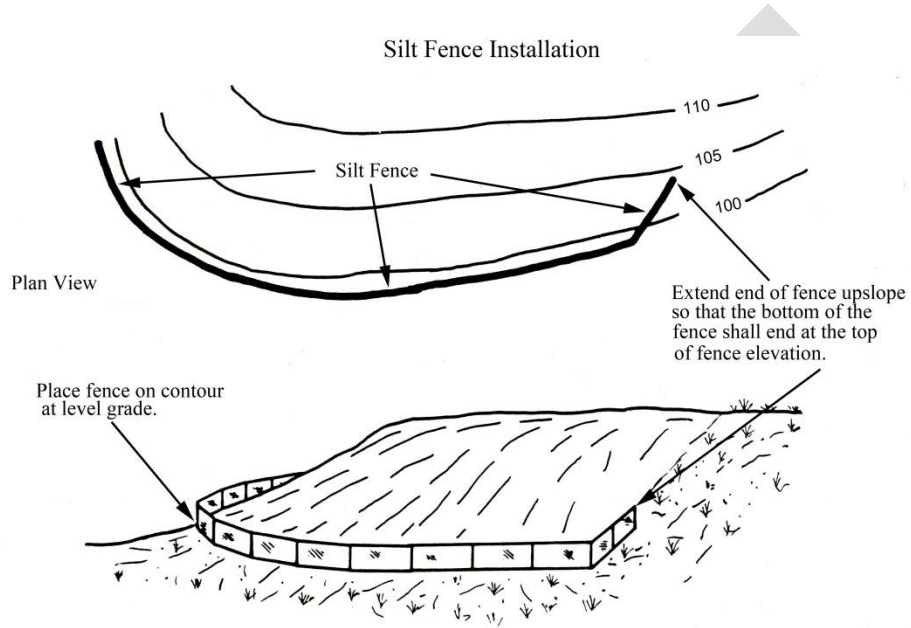

From Erosion and Sediment Pollution Control Manual (1990)

DRAFT

Figure 2.7.
Cross - section of Silt Fence Installation

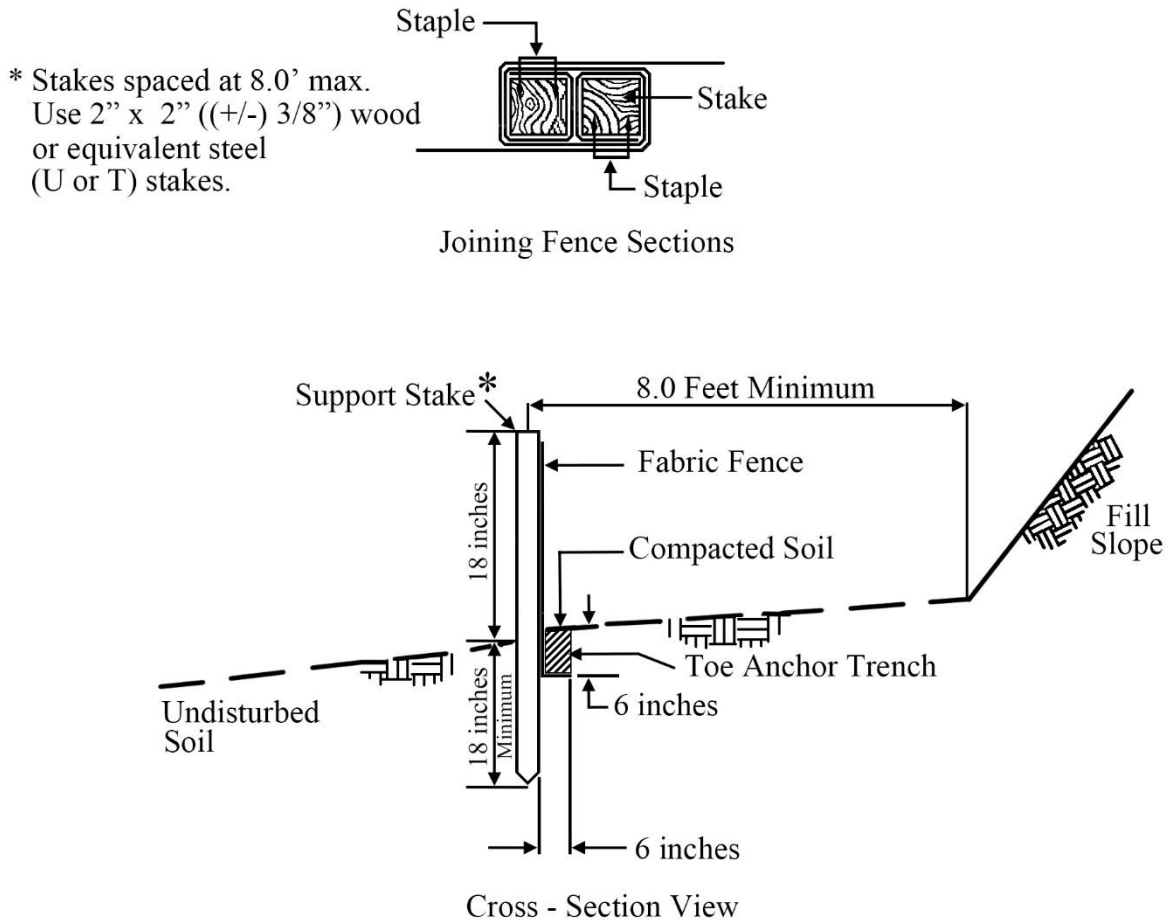

The excavation for the fence should not disturb any more soil area than is necessary. A small plow works well in constructing the trench. An additional advantage of using a plow is that the sod can be placed back with most of the vegetation intact.

The disturbed area should have a temporary seed mix planted immediately after the fence is installed. This is very important in preventing washing or piping problems.

Pennsylvania's typical weather places additional burdens on silt fence installations. Wind and snow loads can have a significant effect on filter fence installations, tearing the filter cloth from its supports or creating bows in the fence that have the potential to then fail with a sediment and water load. Several manufacturers specify 8.0 feet post spacing. The Department believes this distance is too long for an installation expected to last more than a single construction season. It is recommended that 4.0-5.0 feet post spacing be utilized. The posts should be durable and large staples should be utilized to fasten the fence to the posts.

The fence perimeter should be inspected at least weekly and after every stormwater event, to look for problem areas. It may be necessary to regrade eroded areas, remove accumulated sediment, or repair the fence to maintain the effectiveness of the installation.

For additional information on silt fence, see the Department's guidance document "Chapter 102 Erosion and Sediment Pollution Control Program Manual" (363-2134-008).

2.9.2 *Super Silt Fence*

Super Silt Fence is durable filter fabric fence backed by a wire mesh, similar to chain link fence and supported by sturdy galvanized steel poles. This type of filter fabric fence withstands wind and water forces better than standard filter fabric fence. It has a tendency to remain standing longer if installed properly and checked regularly for problems. Super silt fence may be used to control runoff from some small-disturbed areas where the maximum slope lengths for reinforced silt fence cannot be met and sufficient room for construction of sediment traps or basins does not exist.

Only those fabric types specified for use as silt fence by the manufacturer should be used. The maximum slope length, in both existing and final grade, above any super silt fence should not exceed that shown in Table 2.2 (Maximum Slope Length for Silt Fence). The slope length shown is the distance from the fence to the drainage divide or the nearest upslope channel. NOTE: Slope length is not increased by use of multiple rows of super silt fence.

Super silt fence should not be used in areas where rock or rocky soils prevent the full and uniform anchoring of the fence or proper installation of the fence posts. It should be used only where access exists or can be made for the construction equipment required to install and remove the chain link fencing (e.g. trencher and posthole drill). Super silt fence should be installed at level grade. Both ends of each fence section should be extended at least 8.0 feet upslope at 45 degrees to the main fence alignment to allow for pooling of water (see Figure 2.6 Silt Fence Installation).

Super silt fence should be installed according to the details shown in Figure 2.8. An 8.0-inch deep trench should be excavated, minimizing the disturbance on the downslope side. The bottom of the trench should be at level grade. A chain link fence should be installed in the downslope side of the trench with the fence on the upslope side of the support poles. Poles should be 2½ inches diameter galvanized or aluminum posts set at 10.0 feet maximum spacing. Poles should be installed a minimum 36 inches below the ground surface and extend a minimum of 33.0 inches aboveground. A posthole drill is necessary to do this for most sites. Poles do not need to be set in concrete. No. 7 gauge tension wire should be installed horizontally through holes at top and bottom of chain-link fence or attached with hog rings at 5.0 feet (max.) centers. Filter fabric should be stretched and securely fastened to the fence with wire fasteners, staples, or

preformed clips. The fabric should extend a minimum of 33.0 inches above the ground surface. At fabric ends, both ends should be overlapped a minimum of 6.0 inches, folded, and secured to the fence. The fabric toe should be placed in the bottom of the trench, backfilled, and compacted.

Figure 2.8.
Super Silt Fence

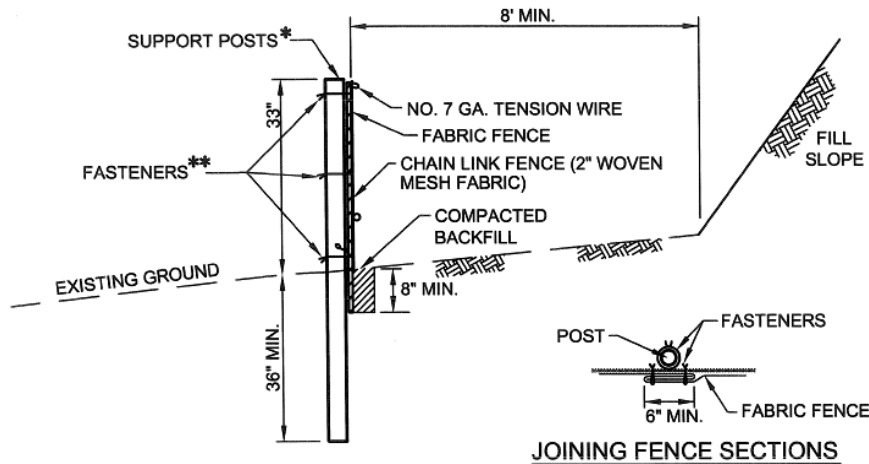

* POSTS SPACED @ 10' MAX. USE 2 1/2" DIA. HEAVY DUTY GALVANIZED OR ALUMINUM POSTS.

** CHAIN LINK TO POST FASTENERS SPACED @ 14" MAX. USE NO. 9 GA. ALUMINUM WIRE OR NO. 9 GALVANIZED STEEL PRE-FORMED CLIPS. CHAIN LINK TO TENSION WIRE FASTENERS SPACED @ 60" MAX. USE NO. 13.5 GA. GALVANIZED STEEL WIRE. FABRIC TO CHAIN LINK FASTENERS SPACED @ 24" MAX C. TO C.

2.9.3 Straw Bale Barrier

For short-term sediment control, straw bale barriers can be used. A typical silt fence backed with straw bales installation and cross-section is illustrated in Figure 2.9 and Figure 2.10. They are usually used for installation of culverts or to catch sediments from small flows while some minor work is being done near the stream.

Figure 2.9.
Silt Fence with Straw Bale Installation

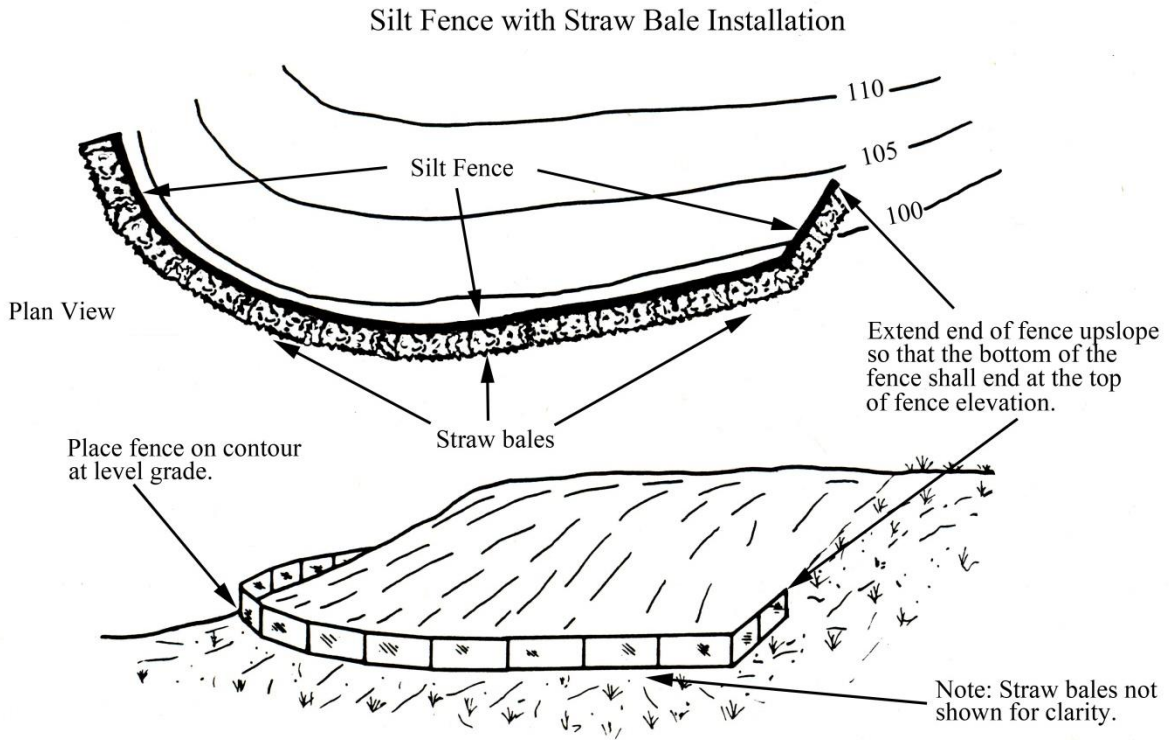

From Erosion and Sediment Pollution Control Manual (1990)

Figure 2.10.
Cross-Section of Silt fence with Straw Bale Installation

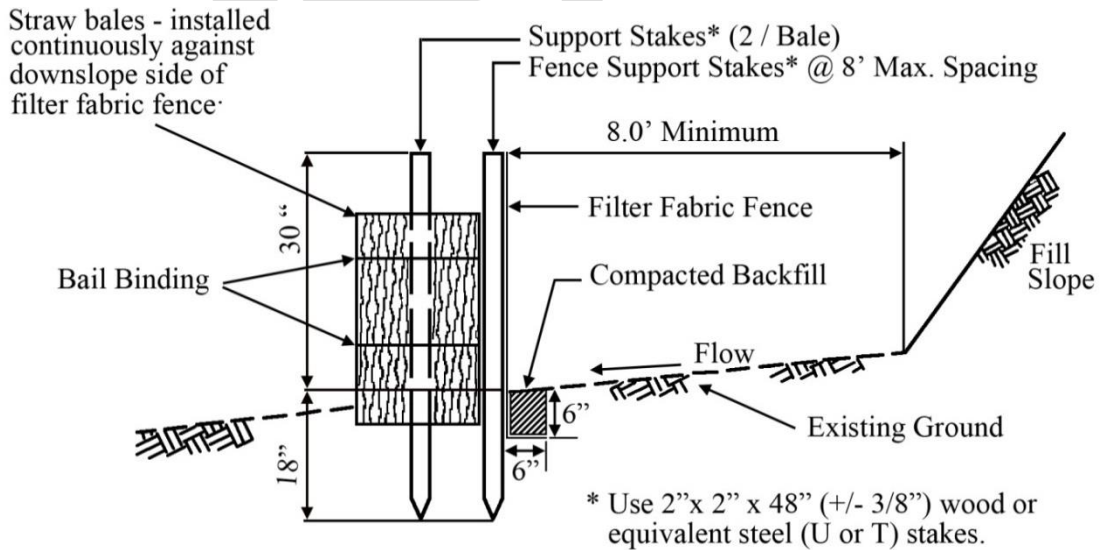

2.9.4 Sediment Traps

Sediment traps are made by constructing a small settling basin to catch, settle, and discharge runoff from a small area. Sediment traps detain sediment-laden runoff from small disturbed areas to allow the sediment to settle out, and then discharge clean water to a natural drainage way. Sediment basins, which are larger than Sediment Traps, will be discussed in Chapter 3. This section focuses on small traps such as those used in conjunction with haul roads. A plan view of this type of sediment trap is shown in Figure 2.11. A cross-section of a sediment trap is illustrated in Figure 2.12.

Haul road sediment traps are used to catch, settle, and store the fine sediment that runs off haul roads. Sediment traps should have a minimum length of 10 feet and a minimum length-to-width ratio of 2:1. Sizing varies according to area, with 10 feet by 20 feet as a common size (20 feet by 20 feet is a large trap). The traps must be sized at a minimum volume of 2,000 cubic feet per contributory acre and be cleaned when the storage volume is reduced to below 1,300 ft³/acre. The sediment trap must have a means to be dewatered. Sediment traps can outlet through a pipe or an overflow spillway section of the embankment.

The shape of the trap should match the equipment that will be used for clean out. A round trap being cleaned by a rectangular loader bucket is not a good idea. A rectangular trap at a slight angle to the roadway is a better option. All haul road sediment traps require frequent cleaning when the permit is active. Spacing of the traps usually varies from 200 feet to 400 feet depending on roadway slope and amount of traffic. In sensitive watersheds, a minimum spacing of 200 feet is recommended.

There is often confusion over whether to use a sediment trap or design for the larger sediment basin. Sediment traps are designed for a minimum of 2,000 ft³/acre but may also be used to control runoff from other areas when the total drainage area is ≤5 acres. Sediment controls for active mining areas must be designed to the normal sedimentation basin standards, which require 7,000 ft³/acre total storage volume. Small areas usually contribute lesser amounts of sediment on a unit area basis than do larger areas. This is due to the decreased amount of gully and channel erosion that takes place on smaller areas. In addition, sediment traps for support areas that cannot be conveyed to the site's primary erosion and sediment control, require a minimum of 5,000 ft³/acre. Contact the appropriate District Mining Operations office to determine situations where sediment traps could be used.

Sediment traps may be used along with normal channels and basins. The use of sediment traps allows the erosion and sedimentation control to be located closer to the source. When sediment traps are utilized along with normal sedimentation basins, the capacity of a sediment trap can be used to offset the required capacity of a sedimentation pond.

The sediment trap must be part of an overall erosion and sedimentation plan. As stated previously, a sediment trap may be used for small areas below the collection channels. They may not be used to separate large areas to avoid the construction of channels and ponds or to avoid National Pollutant Discharge Elimination System (NPDES) permitting. Measures such as mulching planted areas and surfacing of haul roads should be part of the plan to use sediment traps.

For further information on the design of sediment traps, see the Department's technical guidance "Chapter 102 Erosion and Sediment Pollution Control Program Manual" (363-2134-008).

Figure 2.11.
Haul Road Sediment Trap

Haul Road Sediment Trap

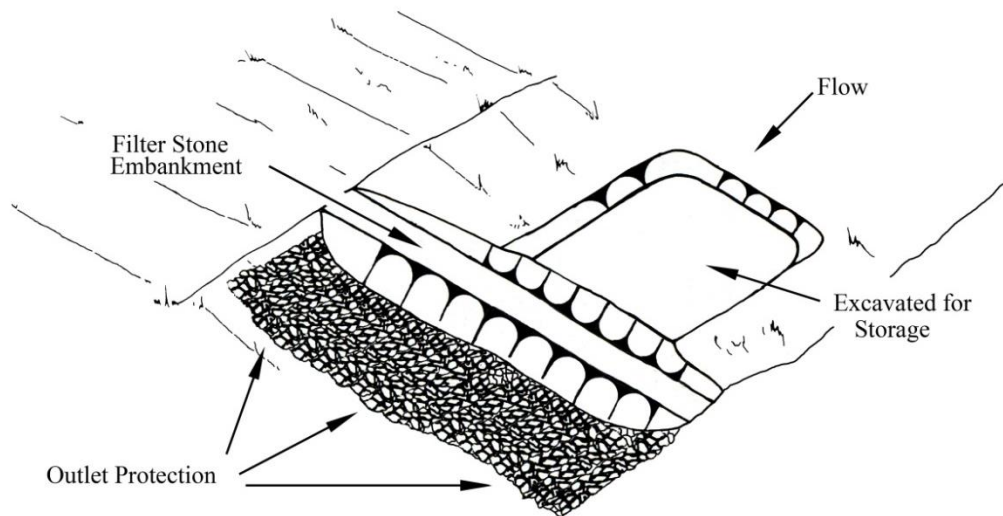
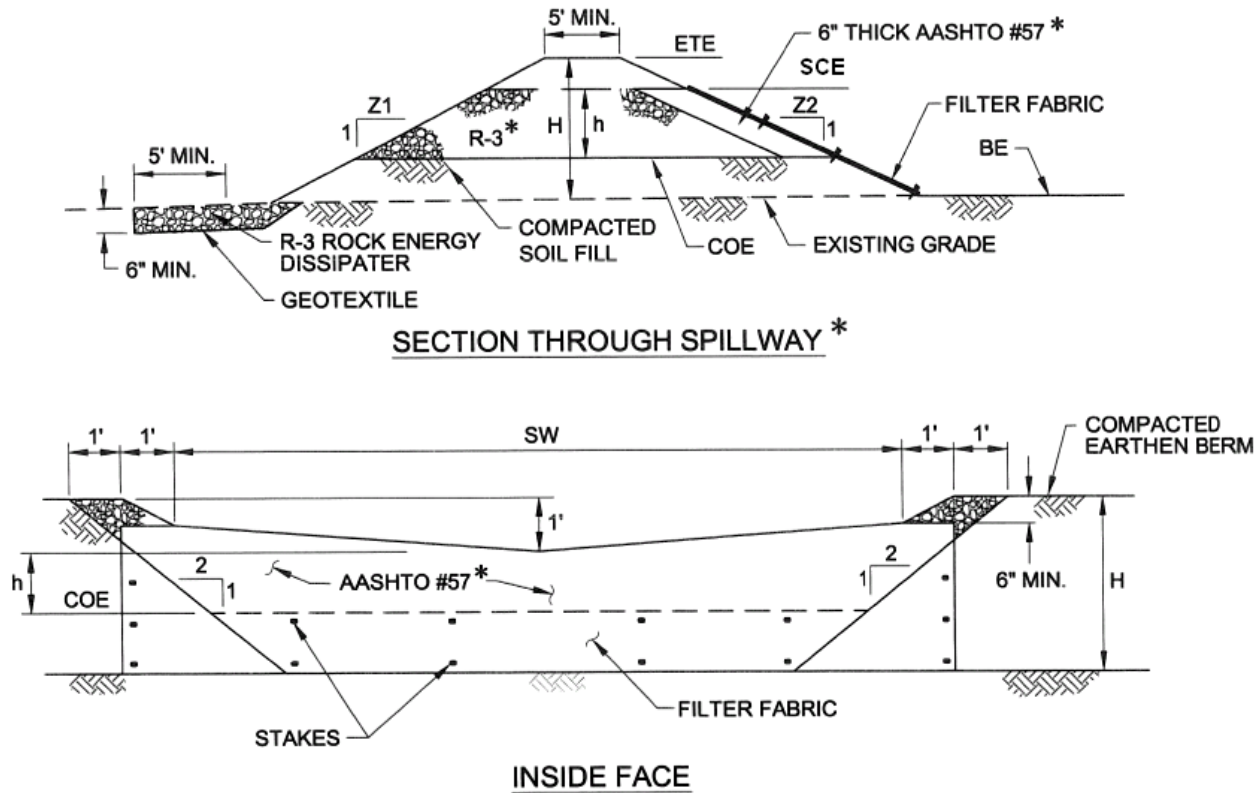

Figure 2.12.
Cross - Section of a Sediment Trap



* In Special Protection Watersheds, embankment outlets composed entirely of rock above the spillway crest (with AASHTO R-3's or larger as the main body and the inside face containing AASHTO #57 stone or smaller) must include a 6.0 inch thick layer of compost or clean sand installed on top of the AASHTO #57 stone and securely anchored.

2.9.5 Compost Filter Socks

Compost filter socks have been developed as an alternative to silt fence. They come in many diameters and are easier to install, inspect, and maintain than silt fence. The composition of filter socks varies, with some made to decompose, while others are made to be removed after the vegetation is established. They are meant to be temporary controls suitable for downslope protection prior to building a sediment basin or a road. Filter socks should be used for short-term disturbances, not for long-term sediment control. Please see the Department's guidance document "Chapter 102 Erosion and Sediment Pollution Control Program Manual" (363-2134-008) for a complete discussion.

Compost socks consist of a biodegradable or photodegradable mesh tube filled, typically using a pneumatic blower, with a coarse compost filter media that meets certain performance criteria (e.g. hydraulic flow through rate, total solids removal efficiency, total suspended solids removal efficiency, turbidity reduction, nutrient removal efficiency, metals removal efficiency, and motor oil removal efficiency).

Compost socks are flexible and can be filled in place or in some cases filled and moved into position. They are especially useful on steep slopes. Heavy vegetation should be removed prior to installing the sock. Compost socks can also be used on rocky slopes if sufficient preparation is made to ensure good contact of the sock with the underlying soil along its entire length. They may also be used on pavement as a perimeter control. Socks used in this manner range in diameter from 12.0 inches to 32.0 inches. (Note: The flat dimension of the sock should be at least 1.5 times the nominal diameter. Also, some settlement of the tube typically occurs after installation.). The nominal diameter of the tube is the dimension to be used for design purposes. Socks with diameters less than 12 inches should not be routinely used on mine sites. In general, a 12.0-inch diameter sock may be used for slopes not exceeding those appropriate for standard (18.0 inch) silt fence. Eighteen-inch (18.0 inch) diameter socks may be used where slope lengths do not exceed the maximum for reinforced silt fence, and 24.0 inches diameter socks may be used where slope lengths are acceptable for super silt fence.

As with other sediment barriers, compost socks should be placed parallel to contour with both ends of the sock extended upslope at a 45-degree angle to the rest of the sock to prevent end-around. Socks placed on earthen slopes should be anchored with stakes driven through the center of the sock or immediately downslope of the sock at intervals recommended by the manufacturer. Where socks are placed on paved surfaces, concrete blocks should be used immediately downslope of the socks (at the same intervals recommended for the stakes) to help hold the sock in place.

The anticipated functional life of a biodegradable filter sock is six months, and one-year for photodegradable socks. Some other types may last longer. Mine sites anticipated to last longer than the functional life of a sock should plan to replace the socks periodically or use another type of erosion and sedimentation control.

Upon stabilization of the tributary area, the compost sock may be left in place and vegetated or removed. In the latter case, the mesh is typically cut open and the mulch spread as a soil supplement. In either case, the stakes should be removed.

Stakes may be installed immediately downslope of the sock if specified by the manufacturer. Traffic should not be permitted to cross filter socks. Accumulated sediment should be removed when it reaches half the aboveground height of the sock and disposed in the approved place designated on the E&S plan. Socks should be inspected weekly and after each runoff event. Damaged socks should be repaired according to manufacturer's specifications or replaced within 24 hours of inspection.

For additional information on the use of filter socks, see the Department's technical guidance "Chapter 102 Erosion and Sediment Pollution Control Program Manual" (363-2134-008).

2.9.6 *Earthen Berms*

Earthen berms, built on the contour, can be an effective sediment control measure for small areas in the two- to three-acre range. Their advantage is that an experienced bulldozer operator can build them without leaving his machine and they are relatively problem-free. When the upslope vegetation has been restored to pre-mining conditions, the berm can be graded out, again by one person. These berms may be used on small areas below collection channels or below roadway slopes, but should not replace sediment traps for areas approaching 5.0 acres. Earthen berms can sometimes be used as an alternative to a collection or diversion channel to direct runoff to a sediment trap or sump.

2.9.7 *Vegetated Strips*

Vegetated strips downslope from the mine site, haul road, or erosion and sedimentation controls will help to reduce sediment loading to the receiving stream. Any bare spoil or unvegetated soil downslope of the mine site should be planted and mulched before mining begins. This will serve to reduce the sediment-producing area and take advantage of the sediment-trapping capability of a good grass cover.

DRAFT

3.0 SEDIMENT CONTROL IMPOUNDMENTS

A sedimentation basin removes sediment from runoff originating within the mine site. Sedimentation basins treat runoff from active and reclaimed areas on a mine site, so they generally treat a larger volume of water than the treatment ponds. Flow from sedimentation impoundments can have a direct effect on the receiving streams and on the aquatic life in those streams.

Runoff water from coal stockpiles, coal preparation areas, or acidic spoil must be treated to comply with NPDES limits. The discharge point must also be on the NPDES listing. Treatment of these materials can be completed in a combined sediment/treatment basin or in a separate treatment system.

A sedimentation impoundment is illustrated in Figure 3.1. The volume of the impoundment during the life of the mining operation and the subsequent reclamation is determined according to the size of the land area, including disturbed and undisturbed (acres) draining into it.

The amount of sediment removed from the runoff is dependent upon detention time, geometry of the impoundment, and the size and density of the sediment particles.

The overall size of any impoundment, including the outside dimension of the embankment or cut slope, must be shown to scale on the operations drawings and the land use and reclamation map where appropriate. The inlet and outlet locations must also be shown on the maps, including the collection channel outlets into the basin and the dewatering, principal spillway, and emergency spillway outlets.

Mining regulations at 25 Pa. Code Chapters 77, 86, 87 and 88, contain information on the required effluent quality and the rainfall events that apply to the different effluent standards. These regulations apply to all impoundments. The NRCS's "*Sediment Basin 350*" and "*Pond 378*" documents (ponds in place longer than five-years), (<https://www.nrcs.usda.gov/>) apply to most impoundments. They contain the specific design requirements that control principal and emergency spillway design, embankment construction, and pond configuration. Besides specific design criteria, "*Sediment Basin 350*" and "*Pond 378*" contain most of the requirements found in 25 Pa. Code Chapters 77, 86, 87, 88, 102 and 105. In addition, for "*Sediment Basin 350*," a static factor of safety of not less than 1.3 must be demonstrated.

The Dam Safety and Encroachments Act, 32 P.S. §§ 693.1-693.27 and its 25 Pa. Code Chapter 105 regulations protect the safety of the public, prevent unreasonable interference with water flow and navigation and protect water quality and carrying capacity of watercourses. Chapter 105 regulations apply to all impoundments over a certain size drainage area, impoundment capacity, or embankment height. These regulations usually do not apply to the impoundments on most mine sites because of their small size.

While "*Sediment Basin 350*" and "*Pond 378*" apply to smaller low-hazard impoundments, NRCS Earth Dams and Reservoirs (Technical Release – 60 revised July 2005), applies to high-hazard or larger impoundments. When Earth Dams and Reservoirs apply to a mining impoundment, it is usually because the structure is located in an area where a failure would affect downstream properties.

Figure 3.1.
Sediment Impoundment Configuration

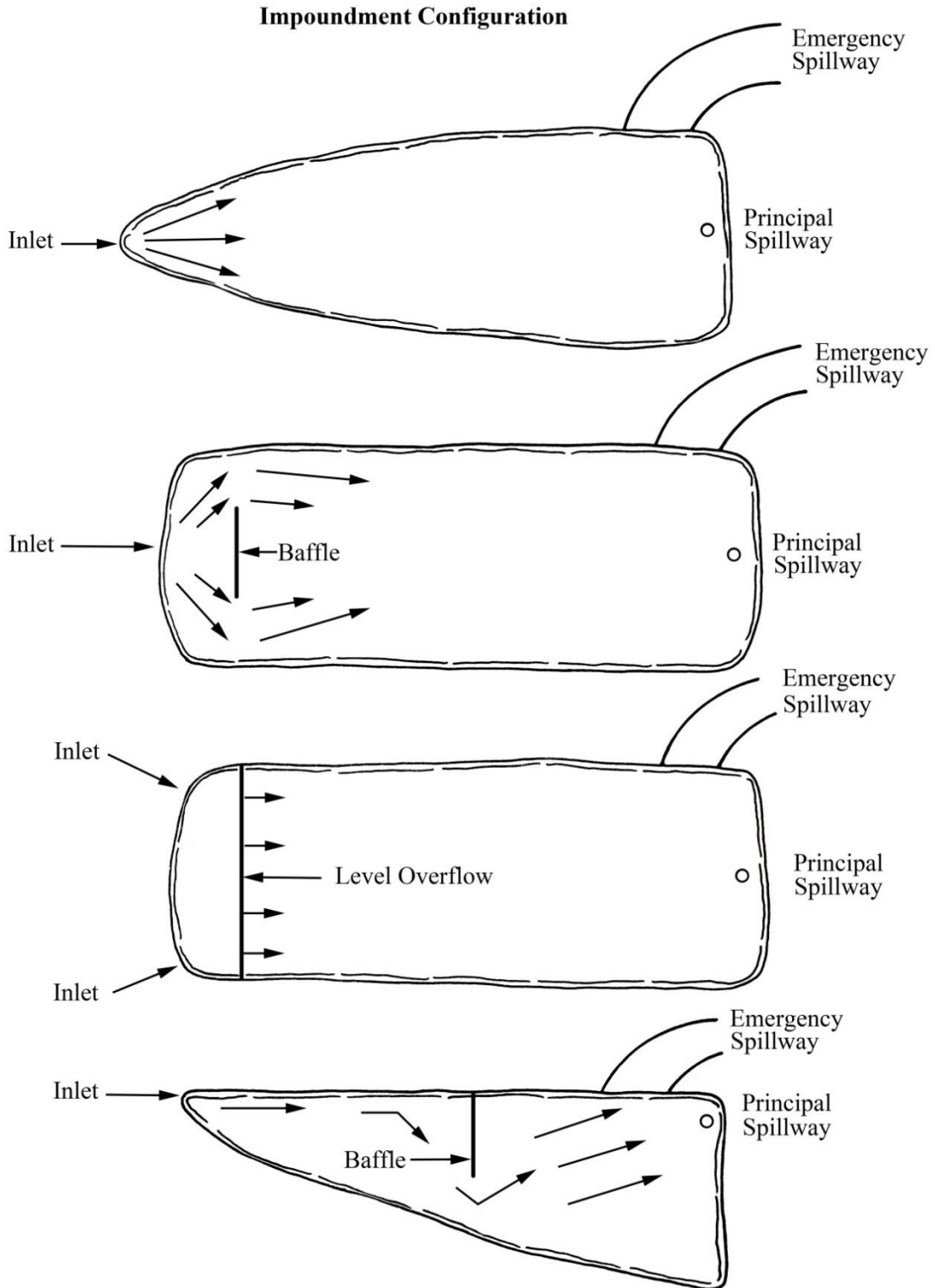

FOR DISCUSSION PURPOSES ONLY (AGGREGATE ADVISORY BOARD)

The Federal Mine Safety and Health Administration (MSHA) are responsible for the safety of miners and the public. The MSHA approval is required for impoundments over a certain size. Table 3.1 shows when different regulations or standards apply.

Table 3.1: Applicable Impoundment Regulations

Requirements	Situations Where Requirements Are Applicable
PADEP Chapters 87	All impoundments.
PADEP Chapter 102	All erosion and sedimentation control impoundments.
PADEP Chapter 105	Impoundments which meet any of the following: <ul style="list-style-type: none"> • Maximum inside embankment height > 15 feet. • Maximum storage > 50 ac feet (2,178,000 cu. feet). • Maximum drainage area > 100 acres.
Review by Bureau of Waterways Engineering, Required	All impoundments, Size Category (SC) A, B and C except for temporary SC C. All impoundments, Hazard Potential Category (HPC) 1, 2 and 3 except for temporary HPC 4.
NRCS Sediment Basin 350	All temporary (< 5 years) erosion and sedimentation impoundments.
NRCS Ponds 378	All impoundments, including permanent erosion and sedimentation impoundments.
NRCS TR-60, Earth Dams and Reservoirs	Impoundments which meet any of the following: <ul style="list-style-type: none"> • Maximum height > 35 feet. • Storage (ac feet) x height (feet) > 3000 ac feet. • All dams located in predominantly rural or agricultural areas where failure may damage isolated homes, main highways, or minor railroads or cause interruption of service for relatively important utilities.
MSHA	Impoundments which meet either of the following: <ul style="list-style-type: none"> • Maximum height > 20 feet. • Maximum storage > 20 ac feet (871,200 cu feet).

3.1 Chapter 105 Impoundments (Title 25 Pa. Code §§ 87.112, 88.102 and 105.3)

A Dam Safety Permit is required for an impoundment if:

- The contributory drainage area exceeds 100 acres, or
- The greatest depth of water measured by the upstream toe of the dam at maximum storage elevation (top of embankment) exceeds 15 feet, or
- The impounding capacity at maximum storage exceeds 50 acre-feet (2,178,000 cu. feet).

The District Mining Operations office will review the application, including processing of the additional permit fee when the dam is classified as Size Category C and Hazard Potential Category 4 according to criteria at Section 105.91. For this category of impoundments, failure of the impoundment would not be expected to cause loss of life (no permanent structure for human habitation located downstream). In addition, a failure would have minimal economic loss (damage to private or public property with no significant effect on public convenience downstream). Finally, this category of impoundments will not remain as permanent post-mining structures.

When the mining permit includes a dam permit, the Dam Safety and Encroachments Act will be checked on the issued mining permit's face sheet and include any special conditions that apply to the additional activities.

If the required impoundment storage is larger than a Size Category C and a Hazard Potential Category 4, the permit application for the impoundment along with an environmental assessment will be forwarded to the Division of Dam Safety, Bureau of Waterways Engineering and Wetlands, along with comments from the District Mining Operations Office, for review and processing. In these cases, the design and construction of the impoundment must comply with the NRCS Earth Dams and Reservoirs (Technical Release No. 60, July 2005). Impoundments that are to remain as permanent post-mining impoundments will also be reviewed by the Division of Dam Safety, Bureau of Waterways Engineering and Wetlands. If modifications to the impoundment can be achieved to reduce the size or drainage area to below the above standards, the Bureau of District Mining Operations will be the permitting agency.

3.2 Permanent Impoundments (25 Pa. Code §§ 77.530, 87.111, 88.101, 88.196 and 88.301)

Impoundments constructed as part of the mining operation may be allowed to remain as post-mining impoundments, provided the following conditions are met:

- The quality of the impounded water is suitable for the intended use and will meet the applicable Sections 77.522, 87.102, 88.92, effluent standards. Examples of post-mining uses include livestock management, fire protection, wildlife habitat, storm water management, and recreation.
- The constructed impoundment meets all Department design standards. Any proposed changes to the impoundment shall be included in the request for the structure to remain. Proposed changes could include deletion of some of the drainage area to the impoundment, capping of the dewatering pipe, and changing the principal or emergency spillway elevation or configuration.
- The operator must provide the Department with a notarized letter from the landowner, consenting to and agreeing to maintain the impoundment after release of all bonds from the permit area. Until final Stage III bond release, the operator is responsible for any maintenance required.

Common uses for post-mining impoundments include livestock watering, fish and wildlife habitat, recreation and/or fire protection. In most cases, the dewatering pipe or valve will be capped or closed, and the water elevation will be allowed to rise. The emergency spillway must be free of obstruction and properly lined. As most post-mining impoundments will have a permanent pool and consequently less storage volume to route a large storm, the drainage area to the impoundment should be reduced. Effects of post-mining drainage on the existing drainage system should be considered. The local NRCS office can provide assistance in determining drainage areas and pond sizes necessary to fulfill a given function.

The Cooperative Extension Service of the Pennsylvania State University has published "Fish Ponds, Construction and Management in Pennsylvania" which provides useful information on fish management. Information on obtaining this document can be found in the reference section of this manual.

The Pennsylvania Fish and Boat Commission (PFBC) can answer questions concerning fish management and provide a current list of commercial hatcheries.

The Department will conduct a field review of all impoundments proposed to remain after mining and reclamation. Post-mining impoundments that meet Chapter 105 criteria will be referred to the Division of Dam Safety, Bureau of Waterways Engineering for their approval, unless the impoundment or drainage area is modified such that the impoundment no longer meets Chapter 105 criteria.

3.3 Mine Safety and Health Administration Impoundments (30 CFR 77.216-1 and 77.216-2, and 25 Pa. Code § 87.112)

The MSHA requires stringent design and construction standards for impoundments if the embankment, as measured from the upstream toe to top of embankment is, 20 feet or more, or the total storage volume is 20 acre-feet (871,200 cu feet) or more, or the impoundment, as determined by the MSHA District Manager, presents a hazard to coal miners.

All impoundments subject to these criteria as established in 30 CFR 77.216-1 and 77.216-2 should have a duplicate set of the plans, with one set submitted to the District Manager of the MSHA and one set submitted to the Department. The Department will review plans for impoundments under the mining regulations and, as part of its review, will consider comments by the MSHA.

3.4 Combined Sediment and Treatment Impoundments

Under certain conditions, an impoundment that was designed as a sediment pond may need to function as a combined treatment/sediment impoundment. When the runoff water contacts a coal stockpile, coal preparation area, or acid producing spoil, the water (contact water) must be treated to the Mine Drainage Treatment Facilities limits (effluent limits) in the NPDES permit.

This contact water can contain high levels of metals and acidity. The treatment should be applied at the inlet to the pond and a second pond may be required to polish the treated water. While the pond may be designed as a sedimentation basin, the final configuration and sizing criteria must be such that the treatment facility effluent limits are met consistently.

3.5 Pond Design (25 Pa. Code §§ 77.531, 87.73, 87.112)

When a Chapter 105 permit is required, the detailed design plan for a structure shall be prepared by, or under the direction of, and certified by, a qualified registered professional engineer. When a Chapter 105 permit is not required, the detailed design plan shall be prepared by, or under the direction of, and certified by, a qualified registered professional engineer or qualified registered land surveyor.

3.6 Pond Certification – Post-Construction (25 Pa. Code § 87.112)

Sedimentation basins and other impoundments, including treatment ponds, must be constructed in accordance with the approved permit before any disturbance of the area that will drain into the impoundment. The impoundment must be inspected during construction and certified upon completion of construction by a registered professional engineer if:

- It requires a Chapter 105 permit.
- The embankment, as measured from the upstream toe, is 20 feet or more.
- The total storage volume is 20 acre-feet (871,200 cu feet) or more.
- The MSHA District Manager determines that it presents a hazard to coal miners.

Impoundments that do not require a permit under Chapter 105 and do not meet or exceed the MSHA requirements still must be certified by a registered professional engineer or a registered professional land surveyor. The impoundment certification form is contained in the permit application, and is available in the Department's eLibrary or from the District Mining Operations office. The Department will accept computer-generated reproductions of the form provided the reproduction accurately follow the original certification. The Pond Certification Form (5600-BMP-MR0311) is designed to be a front and back one-page form. When submitted as two separate sheets of paper, each page should identify the pond and be signed, sealed and dated. Each impoundment shall be certified that it is being maintained or will be maintained as designed in the approved plan and in accordance with all applicable standards.

3.7 Pond Examinations and Inspections (25 Pa. Code § 87.112)

Bituminous coal mine impoundments shall be inspected by a qualified person designated by the operator at intervals not exceeding 7 days for structural weakness, erosion and other hazardous conditions. Impoundments with an embankment less than 20 feet in height or which have a storage volume of less than 20 acre-feet shall be inspected once

every 3 months unless otherwise required by the Department. The examination should include checking for surface cracks, sloughing, or movement of the toe, noticeable seepage, the obstruction of outlet structures and/or riprap failures. The permittee shall make and retain records of such inspection, including records of actions taken to correct deficiencies found in such inspection. Copies of such records shall be provided to the Department on request.

For bituminous coal mines, each impoundment must be inspected and recertified every year by a registered professional engineer or registered land surveyor for the annual pond certification required by the regulations.

If an inspection discloses that a potential hazard exists, the person who inspected the impoundment shall promptly inform the Department of the finding and provide a remedial action plan to protect the public. A potential hazard could be a pond deficiency, such as slumping of the embankment, or a tension crack in the embankment. A potential hazard could also be the construction of a new house or road directly downslope of the pond. If adequate procedures cannot be formulated or implemented, the Department shall be notified immediately. The Department shall then notify the appropriate agencies that other emergency measures are needed to protect the public.

3.8 Impoundment Capacity (25 Pa. Code §§ 87.108 and 102.13)

Sedimentation impoundments have historically been required to have a capacity of 7,000 ft³/ac for each acre of disturbed area draining to it. This volume was originally established by the regulations in Chapter 87 (Surface Mining of Coal) and Chapter 77 (Noncoal Mining) by reference to the Natural Resources Conservation Service's (NRCS) Standards "350, Sediment Basin," and "378, Pond" which were in effect when the regulations were promulgated. The current versions of those NRCS publications no longer provide specific sizing requirements.

The Department's "Chapter 102 Erosion and Sediment Pollution Control Program Manual" (363-2134-008) for non-mining projects recommends a sediment settling zone of 5,000 cubic feet for each disturbed and undisturbed acre contributory to the basin and a sediment storage zone of 1,000 cubic feet per disturbed acre. Due to the size and duration of earth disturbance on most coal and large consolidated noncoal mines, a dedicated sediment storage zone of 2,000 ft³/ac is still recommended. This capacity of 7,000 ft³/ac is also used by most other Appalachian mining states. Lower impoundment capacities may be considered only where the applicant demonstrates that the nature and expected duration of the proposed mining make such reductions technically sound and would not pose a threat to health, safety or water quality protection. In all cases, the sediment in the impoundment should be removed when the settling capacity is less than 5,000 ft³/ac, or when the sediment accumulation rises to the sediment storage elevation. A settling volume of 5,000 ft³/ac corresponds to approximately 1.4 inches of runoff from the drainage area. With this volume, a 10-year storm would produce discharges from both the principal and emergency spillways.

The drainage area to an impoundment may include small areas of undisturbed ground. As these undisturbed areas can be expected to contribute only small amounts of sediment,

it is not necessary to construct the impoundment for the total runoff and sediment storage volume of 7,000 ft³/ac. In these cases, the impoundment design can be based on 5,000 ft³/ac of runoff storage volume for the undisturbed acreage. The impoundment design does not need to include the additional 2,000 ft³/ac of sediment storage for the undisturbed drainage areas.

Similarly, impoundments for areas that include other facilities (wash plants, asphalt plants, buildings, etc.) that do not present a significant source of sedimentation may also be designed with a sediment settling capacity of 5,000 ft³/acre with no provision for relevant sediment storage. However, for new facilities, the applicant may need to perform an analysis of stormwater runoff pre- and post-development in order to assure compliance with stormwater management requirements (25 Pa. Code § 102.8) post construction.

For the purpose of routing storms through an impoundment (NRCS's "Sediment Basin 350" and "Pond 378"), the normal pool shall be considered to be the sediment storage cleanout level (Figure 3.2 Stormwater Settling Pond).

The Department may require increased pond capacities where needed to meet the antidegradation regulations at 25 Pa. Code § 93.4 and the Fish and Wildlife Protection regulations at 25 Pa. Code §§ 87.138 and 88.62.

Sediment traps used as forebays at the points of inflow to a sediment basin can be utilized as pretreatment to remove heavier sediment particles and may reduce the total volume of the impoundment.

**Figure 3.2.
Stormwater Settling Pond**

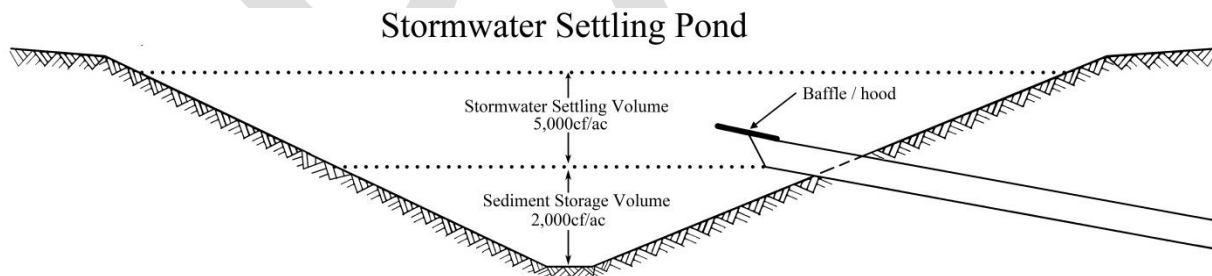

3.9 Principal Spillway (25 Pa. Code § 87.112, and NRCS Sediment Basin 350 and Pond 378)

The requirements for sizing of principal spillways are contained in the NRCS "Sediment Basin 350" and "Pond 378" publications. The Department recommends that all erosion and sedimentation impoundments be designed and constructed with both a principal spillway and an emergency spillway even though neither publication specifically requires a principal spillway for ponds with a drainage area less than 20 acres. The use of a principal spillway reduces the frequency and duration of flow through the emergency spillway, yet allows for a controlled release of the runoff. The criteria contained in the

FOR DISCUSSION PURPOSES ONLY (AGGREGATE ADVISORY BOARD)

two NRCS publications require an increase in the design storm as the drainage area to the impoundment increases.

The bases for sizing principal spillways are as follows:

- Ponds with a drainage area between 20 and 50 acres should have sufficient capacity between the sediment storage level and the emergency spillway to:
 - ❖ Store 2.00 inches of runoff from the watershed, or
 - ❖ Provide the required combination of storage and pipe discharge to accommodate the runoff from the five (5)-year, 24-hour storm event.
- Ponds with a drainage area between 51 and 100 acres should have sufficient capacity between the sediment storage elevation and the crest of the emergency spillway to:
 - ❖ Store 2.50 inches of runoff from the watershed, or
 - ❖ Provide the required combination of storage and pipe discharge to accommodate the runoff from the 10-year, 24-hour storm event.
- Impoundments with a drainage area of more than 100 acres should have sufficient capacity between the sediment and the crest of the emergency spillway to:
 - ❖ Store 3.00 in of runoff from the watershed, or
 - ❖ Provide the required combination of storage and pipe discharge to accommodate the runoff from the 25-year, 24-hour storm event.

The elevation and orientation of the principal spillway inlet is very important in determining the discharge capacity of the principal spillway and the available storage capacity and retention time for the sediment laden storm water. Ideally, the principal spillway inlet should be placed such that full pipe flow is achieved prior to having the water elevation reach the crest of the emergency spillway, but it must not be placed too low in the structure or it will not provide sufficient storage and trapping efficiency for the runoff flowing into the impoundment.

The principal spillway design shall include the inlet elevation, pipe slope, and length of the pipe and routing procedures, such as those in NRCS "*Technical Reference-55*".

Straight barrel spillways are frequently used for small impoundments. If the end of the straight barrel spillway is cut off square, full flow will not develop in the pipe until a significant head is achieved. The head to develop full flow is typically greater than what is available in the ponds. To remedy this situation, the end of the pipe should be cut off diagonally and a baffle or hood placed over the end of the pipe. Figure 3.3 Principal Spillway illustrates a straight barrel spillway design.

Barrel and Riser spillways are more appropriate for ponds that will remain in place for a long time, such as in limestone operations or in larger quarries. Properly installed barrel and riser pipes have some advantages, but the joint between the riser portion and the barrel portion must be strong enough to withstand the forces of wind, and water and freeze/thaw conditions.

On drainage areas of 35-50 acres drainage areas, barrel and riser principal spillways should be used so that adequate storage is available in the impoundment. Barrel and riser principal spillways are subject to a reduction in capacity if an anti-vortex device is not used. This reduction occurs due to the swirling action that greatly reduces the capacity of the structure. A metal plate placed in the center of the riser pipe structure allows the full capacity of the pipe to develop.

Filter fence fabric should never be placed over the inlet or outlet works of a principal spillway. Doing so can cause clogging of the holes and reduces the effectiveness of the impoundment.

Figure 3.3.
Principal Spillway

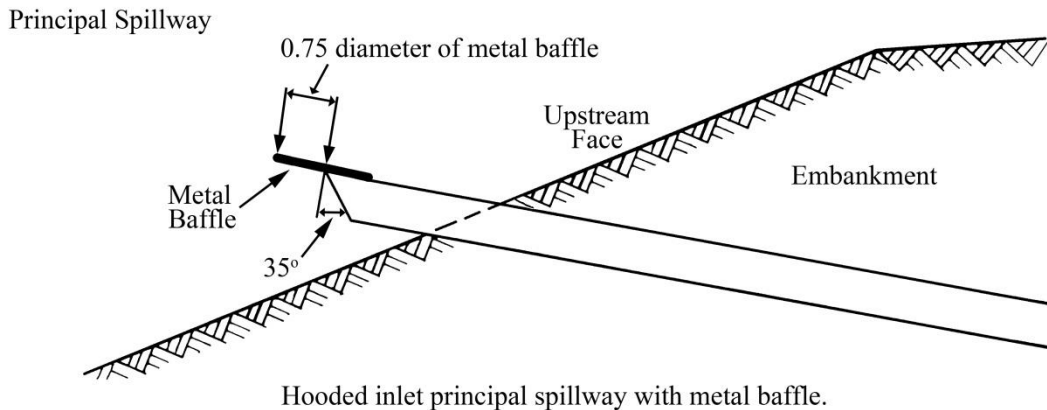

3.10 Emergency Spillway (25 Pa. Code §§ 102.13, 105.98, and NRCS Sediment Basin 350 and Pond 378)

Every sediment basin should be provided with an emergency spillway. The emergency spillway is the fail-safe mechanism for the pond. Proper sizing, construction and lining are essential to emergency spillway efficiency. If runoff inflow is much greater than the pond's ability to discharge and store it, the emergency spillway must discharge without the pond embankment failing. Almost all pond failures result from the emergency spillway being cut by high velocity water and then the water washes out the pond's embankment. For this reason, it is important for the emergency spillway to be constructed on original ground, not on fill on the embankment.

The Department requires that all sedimentation impoundments be capable of safely conveying the routed 25-year frequency peak discharge. NRCS's "*Sediment Basin 350*" and "*Pond 378*" require impoundments from 20 to 100 acres in drainage area be capable of passing the 50-year frequency peak discharge. Impoundments over 100 acres in

drainage area require an applicant to obtain a Chapter 105 Water Obstruction and Encroachment permit and submit an Environmental Assessment with the permit application. The design events upon which drainage areas are based are listed in Table 3.2. Design Area Based on Storm Events. The principal spillway capacity can be utilized in passing the design event. The ability of a given sedimentation impoundment to safely route a given design event is determined by developing a runoff hydrograph that takes into account the discharge capacities of both the principal and emergency spillways.

The emergency spillway should be excavated into original ground and protected with an appropriate channel lining. If it is physically impossible to excavate the emergency spillway into original ground, the area must be adequately compacted and lined with suitable riprap with geotextile lining installed beneath. The emergency spillway outlet should convey the flow to a stable watercourse with adequate capacity to receive.

Table 3.2: Design Area Based on Storm Events

Drainage Area	Design Event
less than 20 acres	25-year, 24-hour rainfall
20 acres to 100 acres	50-year, 24-hour rainfall
over 100 acres	100-year, 24-hour rainfall

The slope of the exit channel of the emergency spillway should be shown on the impoundment design sheet. A plan view of an emergency spillway is shown in Figure 3.4 Plan View of Emergency Spillway.

Figure 3.4.
Plan View of Emergency Spillway

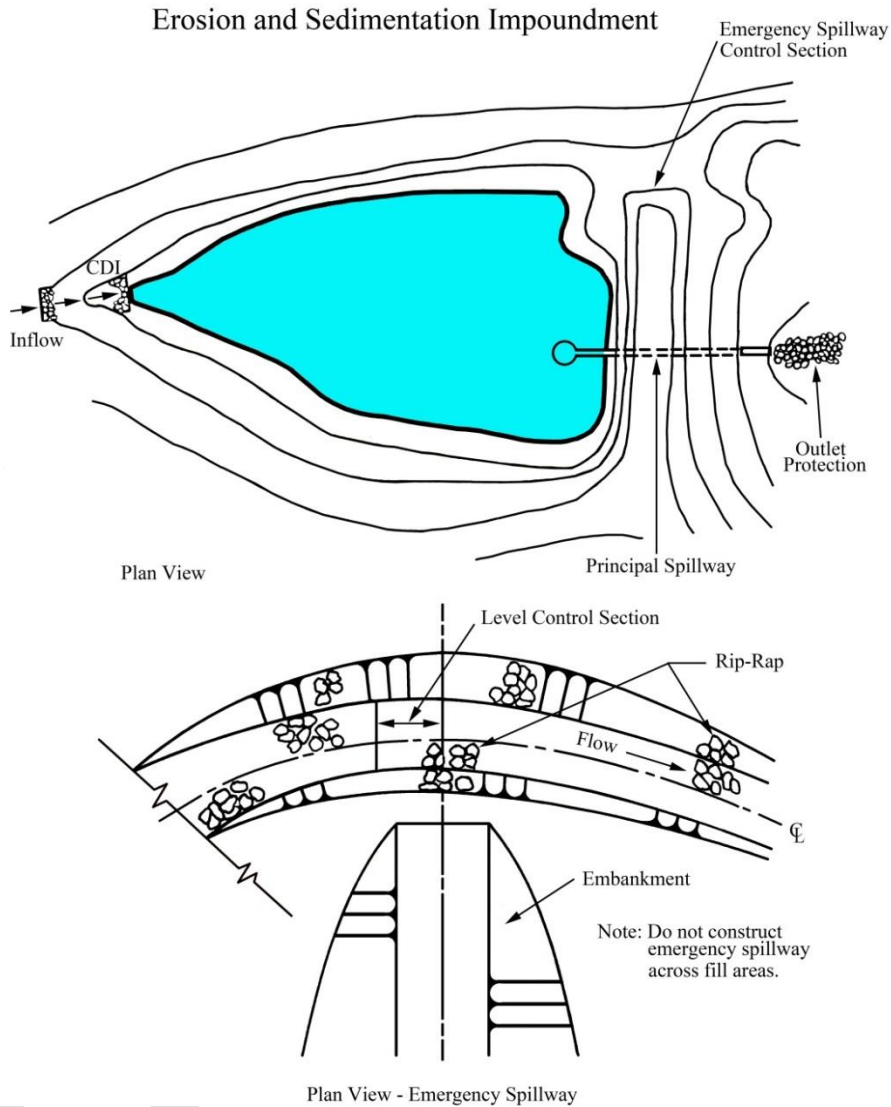

3.11 Freeboard (25 Pa. Code § 102.13, NRCS Sediment Basin 350 and Pond 378)

The freeboard between the design discharge elevation through the emergency spillway and the top of the embankment must be a minimum of 2.0 feet for a 25-year, 24 hour event or 1.0 foot for a 100-year, 24 hour event.

3.12 Impoundment Dewatering (NRCS Sediment Basin 350)

All impoundments are to be designed to dewater to the sediment storage volume in no less than two (2) days and no more than seven (7) days. This allows time for settling and

for the impoundment to empty should a second significant rainfall event occur. Manual dewatering with a valve on the dewatering pipe is required on sensitive watersheds and recommended on other watersheds. Manual dewatering allows the mine supervisor to determine when the collected runoff has cleared and then release it at a controlled rate. All permit applications with manual dewatering devices must contain a narrative describing the operation of the dewatering device including operation after personnel are no longer on site.

The dewatering device is an important element of the pond's design. Practice has shown that smaller pipes are prone to plugging and several small dewatering pipes in one impoundment should be avoided. A four (4) inch pipe has been found to be the minimum size that does not plug with small debris. When a barrel and riser principal spillway is used as a dewatering device, the riser pipe perforations should consist of two (2), three (3,) or four (4) columns of one inch holes spaced one foot vertically. To prevent plugging of the holes, the minimum diameter should be one (1) inch. When additional capacity is needed, an additional column of holes can be added or the top one or two rows of holes can be of a larger size.

The "Orifice equation" can be used for pond dewatering calculations with barrel and riser pipes where:

$$Q = c (A) (2gh) (.5)$$

$$(c) = 0.6$$

$$(A) = \text{the area (ft}^2\text{),}$$

$$(g) = 32.2 \text{ feet/sec}^2 \text{ and}$$

$$(h) = \text{head in feet.}$$

This calculates "Q" in ft³/sec. The impoundment dewatering calculations should be included with the permit application. Hand calculations to determine dewatering time can be done with the following information.

- Elevation
- Storage Volume
- Change in storage volume
- Discharge
- Average Discharge
- Time per unit change in storage volume
- Accumulated time

3.13 Improving Impoundment Efficiency

There are many ways of improving the sediment trapping efficiency of an impoundment. The efficiency of the impoundment can be increased by increasing the flow path that the sediment-laden water must travel within the impoundment and increasing the surface area of the impoundment.

Runoff enters the impoundment in a slug flow process that can result in “dead spots” in a pond that are not effective in trapping sediment. The slug flow can be reduced by placing baffles or a level overflow near the inflow to the impoundment. This allows flow to better utilize the entire cross-sectional area of the impoundment.

The settling of suspended particles is a function of surface area and surface loading rates of the impoundment. Increasing the surface area of an impoundment will decrease the flow velocity through the impoundment and increase the efficiency. Increasing the volume of the impoundment will increase the detention time and the efficiency.

The shape of the basin is another important factor in determining the efficiency of an impoundment. The impoundment should have a minimum length-to-width ratio of 2:1 where possible, with 4:1 preferred if site conditions permit. The longer the distance between the inlet and the outlet, the more efficient the pond will be. Flow should be uniformly routed through the impoundment, with “dead spots” eliminated by baffles or pond geometry. When the pond geometry (e.g. irregular shape) is limited by site conditions, baffles can be used to increase the flow path that inflow must travel before leaving the impoundment. Baffles are required whenever inflow is coming into an impoundment from two different directions where a 2:1 flow path to pond width cannot be achieved. Baffles can be constructed of geotextile cloth, mine ventilation cloth, plywood, stone, or a dike constructed of suitable material. When installed correctly, baffles work very effectively by restricting flow and longer retention times.

The outlet of the collection channel should discharge to an area covered with riprap or other suitable protection for energy dissipation, at the invert elevation of the impoundment so that additional sediment is not deposited into the impoundment by the runoff flowing over and eroding a steep slope.

Reducing the drainage area to any one impoundment will reduce the amount of channel erosion and decrease the sediment load to the impoundment. Generally, anything that places controls closer to the source will improve the overall efficiency of the plan.

3.14 Chemical Flocculation

Chemical flocculation can be utilized to improve impoundment efficiency. Normal settling is gravitational and dependent on the settling velocity for the different size particles. The physical settling of individual particles under quiescent conditions is described by Stokes' Law. Because the fall of a particle in water is due to gravity, the heavier the particle, the greater chance of settling out. If the runoff has a high percentage of fine-grained silt and clay, the required effluent standards will be difficult to achieve. A chemical flocculant can be added to cause the fine-grained particles to agglomerate. This agglomeration will have the settling characteristics of larger-sized particles.

Flocculants can be utilized to increase the settling efficiency of sedimentation impoundments. Impoundments utilizing flocculants work best with manual dewatering capability to allow for batch treatment. A means to distribute the flocculant throughout the water to be treated is necessary. One way is to add flocculants through pumping and, therefore, a power source must be available. Satisfactory results have been achieved by

using a hydroseeder to achieve the desired mixing effect. Flocculants are also available as “floc logs” which slowly dissolve when contacted by incoming surface water. Floc logs should be located at a sufficient distance above the basin to allow for mixing of the water and the flocculant before entering the basin.

When applied at the proper dosage, flocculants are extremely effective in reducing the suspended solids concentration of the effluent. They allow the settling of fine clay particles that can remain in suspension for days. Flocculants are frequently used for process water, but are not always suitable for use in treating water for discharge to a stream as the chemicals used may adversely impact aquatic life. The use of flocculants used to meet effluent standards must be consistent with the manufacturer’s recommendations and may not pose a threat to water quality. The use of flocculants can be approved on a case-by-case basis.

Specific questions as to the toxicity of a given flocculant can be directed to the PFBC Division of Environmental Services.

3.15 Moat Impoundments

Impoundments must have a minimum length to width ratio of 2:1, but the impoundment can be very long relative to the width. Sediment ponds with a high length-to-width ratio are referred to as contour or moat impoundments, because they follow the contours on a site and resemble a wide trench or moat. Moat impoundments, illustrated in Figure 3.5, have many advantages that favor their use in certain areas. They are well suited for use in areas of steep terrain. They take up less space due to lower embankment heights. The lower embankment height also allows for easier reclamation when the time comes to remove the impoundment. Typically, a small bulldozer can be used for construction and reclamation. Moat impoundments have a lower average depth and longer flow path in comparison to typical erosion and sedimentation impoundments.

In general, moat impoundments are treated the same as typical sediment basins with particular emphasis on the following guidelines:

- Since runoff can enter the upslope face of the impoundment, runoff entering close to the basin outlet can flow directly out of the impoundment without sufficient retention time in the basin to allow for sediment removal. A collection channel on the upslope face should therefore be used to route runoff closer to the basin inlet. Another solution is the use of a pond baffle, extending along the length of the impoundment, to prevent short-circuiting.
- Moat impoundments should be constructed on very flat ground as close to zero (0) percent slope to allow settling to occur and prevent the erosion of already settled particles.
- Rock Filters should be placed every 400 feet to reduce erosion in the bottom of the impoundment and to take into account variations in the bottom elevation.

Whenever possible, the emergency spillway should be constructed in original ground or in an area where the embankment is not at its highest point. Moat ponds should follow the normal criteria for the construction of principal spillways. When the principal and emergency spillways are constructed in the same area of the embankment, it is important that these areas be compacted properly. If the emergency spillway must be constructed in the embankment, it is important that the spillway be lined with a riprap of adequate size. A geotextile should be placed underneath the riprap.

In remaining situations, consideration may be given to reusing existing impoundments from previous mining operations to control sediment from the new mining activities provided that the impoundments will not degrade water quality. Impoundments in acid producing spoil should be avoided. Using an existing impoundment results in the eventual reclamation of the old impoundment and avoids disturbing new areas for the sole purpose of building a sediment basin.

Figure 3.5.
Moat Impoundment

Moat Impoundment

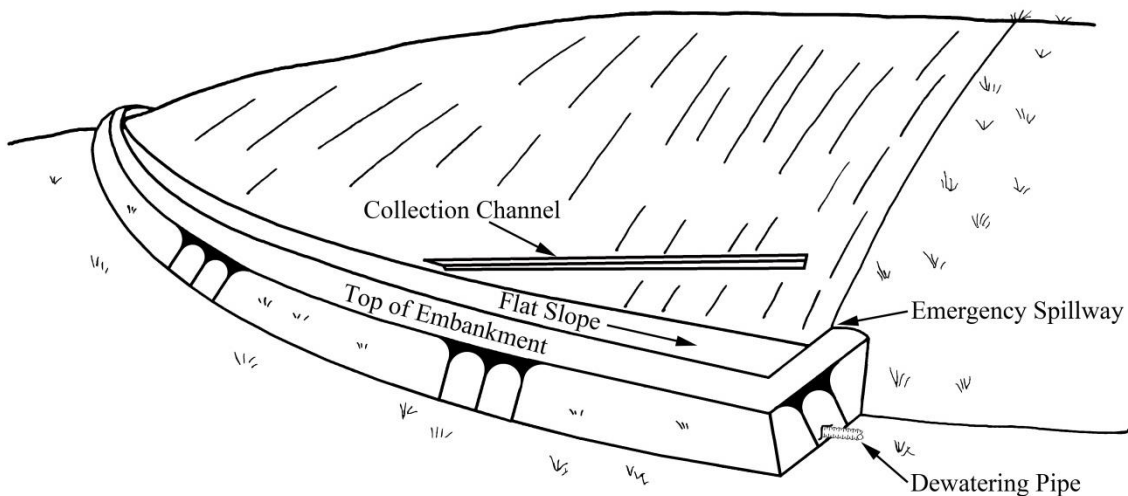

3.16 Impoundment Removal

Erosion and sedimentation impoundments shall remain until the vegetation on the site is successfully established. Permittees must obtain Department approval before removing sedimentation controls. The pond needs to be drained completely, leveled off, have topsoil placed, and planted. Removal of the impoundment should be done during the planting season so that the area can be seeded and mulched as soon as possible.

3.17 Liners (Impoundment and Storage Area) (25 Pa. Code §§ 91.34 and 91.35)

Impoundments and storage areas at underground mines, surface mines, coal preparation plants and coal refuse disposal sites must be constructed in a manner that prevents

groundwater contamination. As a general rule, impoundments for the storage or treatment of mine drainage, contaminated runoff from coal or refuse sources, leachate from a coal refuse area, or water from a mineral processing operation must be equipped with a liner. In addition, coal stockpiles, pollution-forming underground development waste, spoil, and coal processing wastes must be placed on liners that are graded to drain to a collection point and are sufficiently impermeable to ensure lateral flow along the surface of the liner.

3.17.1 Requirements for Liners

25 Pa. Code § 91.34 requires that any activity, which involves the impoundment, production, processing, transportation, storage, use, application or disposal of pollution substances must include measures to prevent such substances from entering the waters of the Commonwealth; and, as such, has been applied to require lining of coal stockpiles. Section 91.35 requires that all impoundments used for the production, processing, storage, treatment, or disposal of pollution substances must be impermeable.

3.17.2 Types of Liners (Liner Materials)

The following materials are commonly used as liners:

- natural clay soils in place (in-situ)
- hydraulic asphalt concrete
- concrete
- soil cement
- soil asphalt
- remolded clay
- sodium bentonite and bentonite-like materials/soil mixtures, and/or
- geo-membranes (synthetic)

Most liners associated with mining activities may be categorized by one of four types. These are:

- natural (in-situ) clays or in-place confining layers
- borrowed clays
- sodium bentonite and bentonite-like materials/soil mixtures
- geo-membranes

Since these types of liners appear to be most utilized by the mining industry in Pennsylvania, further discussion will involve these four types of liners. The other listed liner types will be evaluated on a case-by-case basis by the Department should any operators wish to utilize them.

3.17.3 Minimum Liner Requirements

Impoundments - Specific Discharge Rates: All impoundments described in this section must be equipped with liners capable of achieving specific discharge rates

FOR DISCUSSION PURPOSES ONLY (AGGREGATE ADVISORY BOARD)

no greater than 1.0×10^{-7} cm/sec under operating conditions. Specific discharge is defined by the following equation:

$$D_s = KI, \text{ or } D_s = K(H + L)/L$$

Where:

- (Ds) = specific discharge (cm/sec)
- (K) = hydraulic conductivity of liner (cm/sec)
- (I) = hydraulic gradient (dimensionless)
- (H) = height of water above liner (length in units consistent with the units for L)
- (L) = thickness of liner (length in units consistent with the units for H)

Storage Areas - Hydraulic Conductivities: All storage areas, as outlined in this section must demonstrate a hydraulic conductivity of no greater than 5.0×10^{-5} cm/sec.

Liner Thickness: For natural clays or in-place confining layers and liners constructed of remolded clays or sodium bentonite and bentonite-like materials/soil mixtures, the minimum liner thickness is 2.0 feet.

For liners constructed of geo-membranes (synthetic) the minimum thickness required is 30 mils (0.030 in).

Liner Material Evaluation: In order to evaluate non-synthetic liner materials and liner integrity following construction, the following items must be provided in any proposal:

- Laboratory testing and data listing the percentage amount by volume of bentonite necessary to be mixed with the soil component to achieve the listed hydraulic conductivity value.
- Hydraulic conductivity.
- Liner material density/moisture content relationship.
- Atterberg Limits - A minimum plasticity index of ten is required for any clay soil.
- Sieve Analysis
 - ❖ No coarse fragments greater than one inch (2.54 cm) in diameter.
 - ❖ 50 percent of the soils must pass a No. 200 mesh sieve.

The liner materials to be tested must be compacted to attain a minimum of 90 percent of the maximum dry density as determined by the Standard Proctor

FOR DISCUSSION PURPOSES ONLY (AGGREGATE ADVISORY BOARD)

Test. It is imperative that field densities of constructed liners attain the manufactures suggested laboratory test conditions.

For in-situ clay soil liners, the following information is required in addition to the laboratory testing data:

- A site plan map must be provided to show the soil sample/test locations. These locations must be keyed to the laboratory test results.
- Testing must be conducted at a minimum frequency of one (1) per acre evenly spaced over the areal extent of the site.
- Soil depths must be verified at all test locations by Shelby tube sampling, soil probe or other suitable method and sealed immediately with bentonite.

For synthetic liners, the following information must be provided with all proposals:

- composition and thickness
- hydraulic conductivity
- seam construction
- manufacturer's recommendations on uses, limitations, and installation procedures

All plans for sites where liners will be constructed should contain information regarding groundwater elevations. If necessary, spring collector underdrains should be constructed to convey all groundwater flows away from the liner. These drains should be constructed such that the type of liner, or subbase requirements for the specific liner, does not negatively impact the drain by causing fine-grained material to migrate and block off the underdrain. In most circumstances, it is necessary to provide a geotextile covering of the underdrain itself.

All sites using liner types other than in-situ liners must include a plan for subbase or underlying ground material to be compacted to attain a minimum density of 90 percent of the maximum dry density as determined by the Standard Proctor Test. This action will prevent damage to liner systems from consolidation due to loading during liner construction or loading upon full utilization of the facility.

3.17.4 Quality Assurance and Testing for Liners

a) Non-Synthetic:

Compaction testing must be performed for all non-synthetic liners to document that liner material has been properly compacted to correspond to the density achieved in laboratory permeability testing.

The liner thickness must also be verified.

b) Synthetic:

Testing shall be conducted at a minimum frequency of one (1) per acre evenly spaced over the areal extent of the site. Synthetic liners need only be tested if installed as part of an impoundment. The testing must be done by one of the following methods:

- Procedures recommended by manufacturer, or
- Filling the structure with water and determining the leakage rate over a period of at least five (5) days with corrections for precipitation and evaporation.

3.17.5 Operation and Maintenance for Lined Impoundments

Lined ponds require careful operation and maintenance procedures. These procedures must include the following:

- Inspections - A visual inspection must be conducted each month for any problems with the pond embankment, pond inlet, dewatering system, sludge accumulation level, water level, and pond liner. For ponds with a Chapter 105 Dam Permit, or an approval from the MSHA, more frequent inspections may be required under those permits.
- Dewatering - After each storm event, the pond must be dewatered either automatically through a passive dewatering device or manually.
- Sediment Removal - Accumulated sludge or sediment must be removed when it reaches the sediment storage level. This must be done with appropriate equipment, so that the integrity of the liner is protected.
- Storm Events - After each major storm events, lined ponds must be inspected to ensure that outlet structures are functioning properly. Dewatering devices and spillways must be inspected to make sure they are not obstructed.

4.0 HAUL ROADS (25 PA. CODE §§ 77.631, 77.632, 87.80, 87.160, 88.60)

Haul roads are intended to allow access to the mining operations, but they can also intercept, concentrate, and direct potentially large drainage areas to receiving streams due to the compaction of the construction material. Haul roads are also a source of dust during dry periods. The traveling of heavy equipment on the haul roads during these dry periods can increase the amount of airborne dust, which can be a hazard as well as a public nuisance.

Sediment losses from haul roads are some of the highest from any source. Reed and Hainley (1989) reported that sediment yields on unimproved haul roads that were poorly constructed and had inadequate drainage facilities were over six times as high as sediment yields from properly constructed haul roads. The sediment yield of 148 T/ac for an unimproved haul road was the highest sediment yield of the mine sites monitored by the United States Geological Survey (USGS). The same USGS report indicated that sediment yields from haul roads and newly reclaimed areas were 100 to 300 times greater than the sediment load from agricultural areas planted in hay, pasture, and corn.

4.1 Haul Road Construction

The construction of haul roads should begin with removal of the soil along the proposed haul road. The soil from the road construction should be stockpiled for later reclamation. Removal of organic material aids in establishing and maintaining proper drainage. Whenever possible, haul roads should be constructed on south-facing slopes, as this reduces surface moisture and results in a safer roadway. Cut slopes (side slopes) for haul roads should not be constructed with slopes steeper than 1:1 (45°), unless the slope is excavated from rock. Geotextiles can be used to improve the stability of roads where the sub-grade is poor quality. A road-base of compacted rock will provide stability and allow drainage. A durable, dust-free rock surface maintains the level of the road and moves some water laterally to the roadside channels.

4.2 Location and Cross - Section

The cross-section of the road is important to allow proper drainage and prevent accumulation of water on the road surface. To promote drainage of the road surface, the road should be sloped or crowned at about one-half inch per foot of width. Where the road is cut into the side of a hill, it is better for safety reasons to slope the road towards the cut section and run a channel along the cut slope. Figure 4.1 illustrates typical haul road cross-sections. Regular maintenance is required for all haul roads. Many passes with loaded off-road trucks will create a “W” cross - section, which will concentrate flow in the ruts and direct water to streams and hollows at the low points. Getting the water off the road to the roadside channels where it can be controlled by sediment traps is the objective. To maintain the haul road, regrading and resurfacing of haul roads need to be done when necessary.

Figure 4.1.
Typical Haul Road Cross-Sections

Typical Haul Road Cross Sections

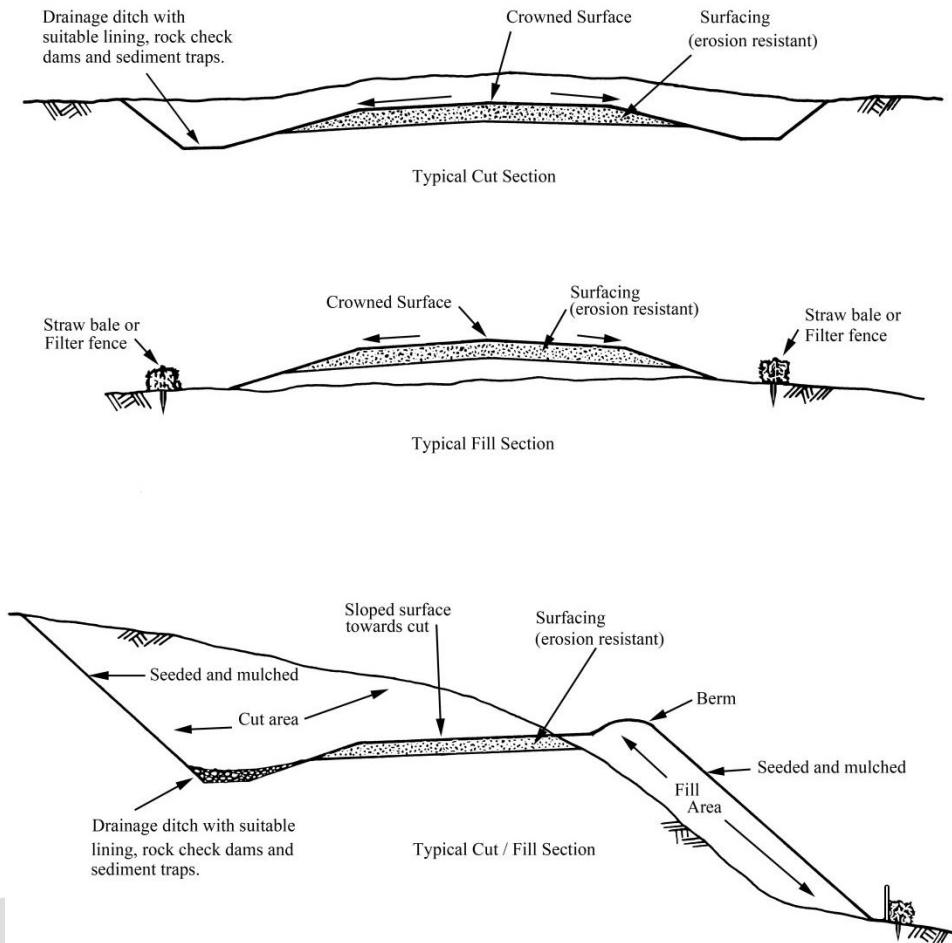

4.3 Culverts

Haul roads can intercept significant runoff, with the impervious surface of the haul road adding to the runoff volume. The uphill roadside channel may need culverts to carry this runoff under the haul road. The culverts should be located so that they only discharge clean water and must have adequate outlet protection. Table 4.1: Haul Road Culvert Spacing may be used as a guide for determining spacing of haul road culverts.

Table 4.1: Haul Road Culvert Spacing

Road Grade	Spacing	
	feet	meters
2.0 percent to 5.0 percent	300 to 500	91.44 to 152.40
6.0 percent to 10 percent	200 to 300	60.96 to 91.44
11 percent to 15 percent*	100 to 200	30.48 to 60.96

(*) Greater than recommended road grade.

When culverts are required to carry flow from a collection or diversion channel under a haul road, the culvert should be sized to convey the maximum design discharge flowing in the channel.

See Chapter 8, *Streams and Wetlands*, Sections 8.1-8.4 for a review of haul road crossings of streams.

4.4 Permit Application

The location of the haul road, including rock filters, sediment traps, collection channels, and culverts must be shown on the application’s Operations Map/Exhibit 9. All new or upgraded crossings of all intermittent and perennial streams require a variance for distance limitations and should be included as part of the public notice.

4.5 Certification (25 Pa. Code § 87.160)

The design and construction or reconstruction of roads utilized for coal surface mining activities must be certified by a qualified registered professional engineer or land surveyor as constructed or reconstructed in accordance with the approved plan.

4.6 Public Highway Access (25 Pa. Code § 86.102)

There are several issues to be considered when an access or haul road must intersect a state or township road. The intersection should be at a location where adequate sight and stopping distances can be achieved. Haul roads should not contribute sediment from channels or the road surface to the public road.

If the public road is a state highway, a Highway Occupancy Permit must be obtained from PennDOT. Applications for Highway Occupancy Permits can be obtained at any PennDOT District Office and may be completed online. This permit is separate from the mining permit. It is the responsibility of the mine operator to obtain the required approval. A copy of the approved Highway Occupancy Permit must be provided to the Department prior to activation of the mining permit. Even “existing” access roads may require a new occupancy permit if conditions under which the “existing” road will be used are changing.

The Highway Occupancy Permit regulates the location, design, safety, construction, maintenance, and drainage of the access or haul road to the state road. The main concerns that must be addressed include:

- Placement of the access or haul road in a safe location with adequate sight and stopping distance for oncoming traffic.
- Preventing water flow from the access road, haul road or mining operation onto the highway, which may cause problems for traffic.
- Preventing the accumulation of mud, soil, and coal onto the highway, that can cause hazardous driving conditions.

4.7 Rock Construction Entrance

Where the access or haul road meets the public access road it is recommended that the first 100 feet of the access or haul road be lined with clean, durable, non-acidic rock (AASHTO #1) to prevent the transfer of mud, dirt and coal onto the public road. Alternatively, the operator could pave the first 100 feet of haul road and achieve equal or better results. See Figure 4.2 illustrates a typical rock construction entrance.

Figure 4.2.
Rock Construction Entrance

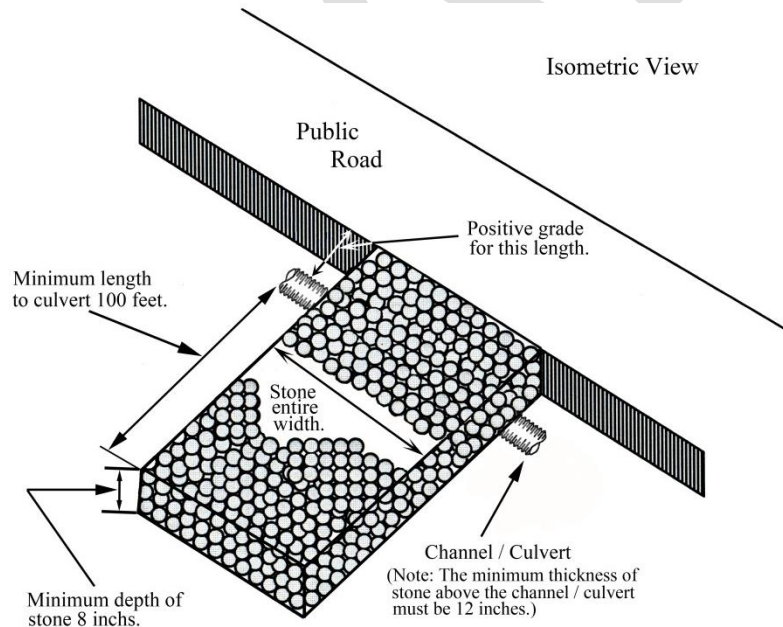

5.0 DISCHARGE EFFLUENT REQUIREMENTS

The Department is authorized to regulate discharges to waters of the Commonwealth by the Pennsylvania Clean Streams Law and its implementing regulations. Pennsylvania has established State water quality standards in 25 Pa. Code Chapter 93, and a National Pollutant Discharge Elimination System (NPDES) permitting process to regulate the discharge of pollutants to surface waters of the Commonwealth 25 Pa. Code Chapter 92a. The U.S. Environmental Protection Agency has reviewed Pennsylvania's water quality standards and its State law NPDES permitting program relating to the federal requirements established by the Federal Water Pollution Control Act, more commonly known as the Clean Water Act (CWA). EPA has delegated authority to administer the NPDES program to Pennsylvania. In addition, Pennsylvania's water quality standards have been reviewed and approved by EPA. Therefore, NPDES permits issued by the Department for discharges from noncoal and coal mining activities meet both State and federal law requirements.

The NPDES permit and the mining activity permit are interdependent, but are reviewed and processed together. The discharge effluent limits for the various types of discharges are contained in the NPDES permit.

The Department's technical guidance "*Developing National Pollutant Discharge Elimination System (NPDES) Permits for Mining Activities/(563-2112-115)*," describes the procedures for establishing effluent limitations and permit conditions for NPDES permits for mine sites. In general, NPDES permits are issued to comply with both technology-based limits, and numeric and general (narrative) water quality criteria designed to protect receiving stream uses and quality. Effluent limits established to comply with water quality criteria are referred to as Water Quality Based Effluent Limits (WQBELs).

Pennsylvania's water quality standards include protected surface water uses, general and numeric water quality criteria for protection of water uses, and antidegradation requirements. Under the antidegradation requirements, existing instream water uses and the level of water quality necessary to protect the existing uses must be maintained and protected. In addition, for High Quality and Exceptional Value Waters, the quality of the water must be maintained and protected. In the case of High Quality Waters, a reduction in water quality may be allowed if the Department finds, after required public participation, that the reduction is necessary to accommodate important economic or social development in the area where the waters are located, and the discharger demonstrates that other existing and designated uses be supported. If the Department has confirmed the presence, critical habitat or critical dependence of federal or State endangered or threatened species in or on a surface water, the Department will ensure protection of the species and the critical habitat. See Section 5.2 - Special Protection Watersheds and Antidegradation Analysis below for additional information if an applicant is proposing a new, increased or additional discharge to a High Quality or Exceptional Value Water.

A fact sheet completed by the Department is required for all draft NPDES permits (25 Pa. Code § 92a.53). The effluent limits and the methodology used to determine the limits and any specific permit conditions should be documented on the fact sheet.

5.1 Discharge Effluent Standards (25 Pa. Code § 92a.12)

The regulation of discharges to surface waters from coal and noncoal mining activities is mandated by the Federal CWA, and the Pennsylvania Clean Streams Law. The CWA establishes a program that is implemented with a NPDES permit. The discharge effluent standards for different types of discharges that are contained in the mining permit are part of the NPDES permitting system

There are two different types of discharge limitations that apply under the CWA:

- The minimum federal technology-based effluent limitations and,
- Pennsylvania's Water Quality-Based Effluent Limitations (WQBELs).

In general, technology-based effluent limitations are uniform standards that apply to classes of discharges. These limits are based on the technological and economic capacity of an industry to control pollution and are referred to as Best Available Technology (BAT). Coal mining discharges and noncoal discharges each have their own separate Effluent Limit Guidelines (ELGs). Water quality-based effluent limitations are based on water quality standards that are necessary to protect surface water.

5.1.1 Coal Mining Discharges

For coal mining, there are two different types of discharge limitations that apply under the CWA, BATs based effluent limitations and WQBELs. Both are technology-based effluent limitations, and are uniform standards that apply to specific industry categories of discharges.

The technology-based limitations may not be adequate to address the effects the mining discharges will have on the receiving stream, nor do they guarantee that the goals of the CWA will be met. Therefore, the water quality based effluent limitations (25 Pa. Code, Chapter 96) focus on the environmental effects that the discharge will have on a stream. They are designed to protect and maintain the existing uses of the stream and may result in stricter limits on additional parameters. The BAT standards assigned to a permit cannot cause in-stream standards for the regulated use of the stream to be exceeded. In many instances, the receiving stream can accept additional loads without exceeding its water quality standards. In cases where the water quality criteria would be exceeded, the Department, through the NPDES permitting process, is required to apply the more stringent water quality-based effluent limitation.

The BAT effluent limitations for active coal mining discharges are set forth in federal regulation 40 CFR Part 434. The effluent limitation standards are found in 25 Pa. Code, Chapters 87-88, and shown in Table 5.1.

**Table 5.1: Summary of BAT Limitations for Coal Mining Activities:
Discharge Limitations Grouping from §§ 87.102 and 88.92**

Summary of BAT Limitations for Coal Mining Activities: Discharge Limitations Grouping			
Group A	30-Day Average	Daily Maximum	Instantaneous Maximum
Iron (total)	3.0 mg/L	6.0 mg/L	7.0 mg/L
Manganese (total)	2.0 mg/L	4.0 mg/L	5.0 mg/L
Suspended Solids	35.0 mg/L	70.0 mg/L	90.0 mg/L
pH	Between 6.0 and 9.0 at all times		
Alkalinity	Greater than acidity at all times		
Group B	30-Day Average	Daily Maximum	Instantaneous Maximum
Iron (total)			7.0 mg/L
Settable Solids			0.5 mL/L
pH	Between 6.0 and 9.0 at all times		
Alkalinity	Greater than acidity at all times		
Group C	30-Day Average	Daily Maximum	Instantaneous Maximum
pH	Between 6.0 and 9.0 at all times		
Alkalinity	Greater than acidity at all times		

5.1.2 Noncoal Mining Discharges

The effluent limitation guidelines for noncoal mining are found at federal 40 CFR Part 436 (Table 5.2 - Summary of BAT Limitations for Noncoal Mining Activities by Types), as well in the Department’s technical guidance “Developing National Pollutant Discharge Elimination System (NPDES) Permits for Mining Activities” (563-2112-115).

Table 5.2: Summary of BAT Limitations for Noncoal Mining Activities by Types: Discharge Limitations from 40 CFR Part 436

Summary of BAT Limitations for Noncoal Mining Activities by Types					
Type of Noncoal Mining Activity	40 CFR 436 Subpart	Technology-Based Requirements			Additional PA Requirements (See Note 1)
			30 Day Avg	1-Day Max	
Crushed Stone (Limestone quarries and crushing/sizing operations)	B	pH*	6-9 at all times	6-9 at all times	TSS 35/70 mg/l Use of std. E&S practices and BMP controls
Construction Sand and Gravel (aggregate for general construction purposes, or materials to be used as fill)	C	pH*	6-9 at all times	6-9 at all times	TSS 35/70 mg/l Use of std. E&S practices and BMP controls.
Industrial Sand (Non-construction uses such as refractories, abrasives, glass making)	D	TSS/ pH*	25 mg/l	45 mg/l 6-9 at all times	Use of std. E&S practices and BMP controls

Note 1: Additional effluent limits, E&SC practices, and BMP controls to be evaluated on a case-by-case basis, considering the type(s) of discharges present and additional WQ protection needs.

(*) within the range of 6.0 – 9.0

All of the other NPDES requirements also apply to setting effluent limits at non-coal mine sites. These include WQBELs found in Section 5.1.4 Water Quality Based Effluent Limits (WQBELs), Reasonable Potential Analysis (RPA) in Section 5.1.6, and Total Maximum Daily Load (TMDL) in Section 5.1.7. 25 Pa. Code § 77.522 includes a requirement for pH (6.0 to 9.0) and “other parameters the Department may require”. For precipitation-induced discharges, limits are expressed as instantaneous maximum values only. For continuous discharges, (i.e., discharges that occur throughout the operating hours of the facility) limits must be expressed as a monthly average and daily maximum. Effluent characterization should identify pollutants of concern for the specific mining operation. Separate characterizations are needed for stormwater and pumped discharges. Effluent limits for noncoal operations typically include iron, manganese, and aluminum if in the coal measures. Osmotic pressure, total dissolved solids, sulfate, chloride, and temperature limits may be applicable to certain discharges.

Due to earth disturbance related to noncoal mining, sediment is a major pollutant of concern. Historically, the 35/70/90 mg/l Total Suspended Solids (TSS) limit has been applied to sediment discharges from noncoal mines. This has proved to be effective at preventing in-stream impacts in most cases. While there is no numeric criterion for any sediment-related parameter, the narrative water quality criteria require the control of substances that produce turbidity or that settles to

FOR DISCUSSION PURPOSES ONLY (AGGREGATE ADVISORY BOARD)

form deposits. In the absence of any other indicators, TSS is generally used to represent turbidity and settleable solids. Reference values of 0.5 mL/L settleable solids and 90 mg/l TSS (instantaneous maximum) from Chapter 87 are generally used as limits for noncoal mine outfalls from sedimentation ponds. See 25 Pa. Code §§ 87.102(a) and 77.522(a)(2).

Stormwater controls typically receive both TSS limits addressing turbidity and settleable solids limits addressing settling. TSS limits apply to discharges during dry weather and more than 24 hours after a precipitation event. Settleable solids limits apply within 24 hours of any precipitation events. Pumped discharges are assigned the TSS limit, however, the settleable solids limit does not apply because the volume of pumped water to be treated is not necessarily related to storm events. For stormwater and pumped discharges resulting from events larger than the 10-year, 24-hour storm, the TSS and settleable solids limits do not apply. Typical stormwater discharge limitations are shown in Table 5.3. Stormwater Discharge Limitations below.

Table 5.3: Stormwater Discharge Limitations

Parameter	30-Day Average	Daily Maximum	Instantaneous Maximum
Total Suspended Solids	35 mg/l	70 mg/l	90 mg/l
Total Settleable Solids	0.5 mL/L Instantaneous Maximum (Sampled within 24-hours of a precipitation event, in lieu of total suspended solids.)		
Any discharges resulting from a precipitation event exceeding a 10-year, 24-hour precipitation event are not subject to total suspended or settleable solid requirements.			
pH	Between 6.0 and 9.0 at all times.		

5.1.3 Types of Discharges

Pit water discharge is discharge of water that accumulates in surface pits and excavations due to precipitation events or the inflow of groundwater. They may be intermittent in nature or continuous in areas of abundant groundwater. Gravity drainage of pit water is not allowed; the water must be pumped to a treatment facility and meet required effluent limits.

Contact water is surface water that has come into contact with coal stockpile areas, or other acid forming materials. It also must be collected, conveyed to a treatment facility, and treated to Table 5.1 Group A (dry weather) effluent limits. Sedimentation basins that receive contact water require treatment to the Group A effluent limits. See Table 5.1. BAT Limitations for Coal Mining Activities: Discharge Limitations Grouping from §§ 87.102 and 88.92.

Process water is water used in the washing and processing of coal or industrial minerals. Process water may be very high in suspended or dissolved solids. Treatment consists primarily of collection, settling, and reuse in a closed loop or

FOR DISCUSSION PURPOSES ONLY (AGGREGATE ADVISORY BOARD)

recirculating system. Flocculants may be needed to provide water suitable for reuse in the system. A completely closed loop system does not generate any discharge. If there is a discharge, it would have to meet Table 5.1 Group A limits or be subject to a more stringent limit.

Stormwater discharges are completely in response to precipitation, and from vegetated areas, soil, and rock/overburden without acid-forming materials. Precipitation-induced stormwater discharges are subject to Table 5.1 Group B and C effluent limits (See Table 5.4 for discharge limitations for specific situations). The Department also has a specific NPDES, General Permit (GP-104) (for stormwater from mine sites). The GP-104 applies to mining-related earth disturbances of one acre or greater which only discharge stormwater and are not in special protection waters.

Table 5.4: Discharge Situations and Applicable Discharge Limitations for Coal Mining

Type of Discharge	Precipitation Events	Effluent Limitations
Pit Water from surface mines	All	Group A
Surface runoff from active mining areas and from areas where Stage 2 reclamation standards have been achieved	Dry weather	Group A
	Less than or equal to 10-year, 24-hour storm	Group B
	Greater than 10-year, 24-hour storm	Group C
All other discharges	Dry weather	Group A
	Less than or equal to 10-year, 24-hour storm	Group B
	Greater than 10-year, 24-hour storm	Group C

5.1.4 Water Quality Based Effluent Limits (WQBELs)

WQBELs focus on the environmental effects that the discharge will have on a stream if the technology limitations are not protective. They are designed to protect and maintain the uses of the stream and may result in stricter effluent limits and apply to additional parameters. The BAT effluent limitations assigned to a permit cannot cause exceedances of instream water quality standards. In many instances, the receiving stream can accept additional loads without exceeding water quality criteria. In cases where the BAT effluent limitations are not protective and water quality criteria would be exceeded, the Department, through the NPDES permitting process, is required to assign the more stringent WQBEL.

The need for WQBELs will be evaluated by the Department in its review of the NPDES application by modeling the proposed discharge and the receiving stream. Modeling may be done using PennTOX software that evaluates the effect of the discharge at Q₇₋₁₀ (7 day mean flow rate - 10-year return period) low flow conditions. For predominately precipitation-induced discharges, modeling may

also be based on a water quality spreadsheet (made available to the applicant through the Department) which compares the contribution of the mine site relative to the watershed area of the receiving stream using a mass balance approach.

The components of the mass balance equation are background stream flow, background stream concentration of the pollutant of interest (usually Al, Mn, or Fe), design average flow of the discharge, concentration of pollutant in the discharge, and the applicable pollutant criterion.

The background stream concentration is computed by averaging the applicants or other published data. The average design flow of the discharge is based on the information provided in the permit application. The total flow is the sum of the upstream flow and that of the discharge. In most cases, when the effluent limitations are being computed, the relative flow of both the stream and the proposed discharge are known. The unknown is the concentration of waste in the proposed discharge. Effluent limits can be modified by adjusting the size of the operational area. For example, reducing the maximum operational area will decrease the size of the discharge relative to the receiving stream, allowing for more dilution and potentially a less restrictive effluent limit.

$$\text{Mass Balance Equation: } Q_T C_T = Q_S C_S + Q_D C_D$$

Where:

- Q_S = Flow rate of the receiving stream
- C_S = Upstream background concentration
- Q_D = Wastewater discharge rate
- C_D = Concentration of pollutant in the wastewater discharge
- Q_T = Resulting downstream flow rates ($Q_S + Q_D$)
- C_T = Resulting downstream pollutant concentration

Solving for C_D gives the required effluent limit:

$$C_D = [Q_T C_T - Q_S C_S] / Q_D$$

This mass balance procedure is conservative in that it does not consider chemical reactions or removal from solution in the form of a gas or a solid. If several instantaneous samples are taken on one or more days, they are averaged for each day, and the maximum of these averages is the daily maximum. Effluent limits can be modified by adjusting the size of the operational area. For example, reducing the maximum operational area will decrease the size of the discharge relative to the receiving stream, allowing for more dilution and potentially a less restrictive effluent limit.

Additional information on determining WQBELs using this method can be found in the Department's technical guidance "Developing National Pollutant Discharge Elimination System (NPDES) Permits for Mining Activities" (563-2112-115).

5.1.5 Effluent Characterization

NPDES regulations require that the applicant characterize the wastewater to be discharged. Any parameters that may reasonably cause an exceedance of in-stream water quality criteria must also be given a WQBEL. This procedure is called effluent characterization.

The regulations at 25 Pa. Code § 92a.21 which incorporates 40 CFR 122.21 (wastewater) and § 92a.32 which incorporates 40 CFR 122.26 (stormwater) require that an applicant submit an effluent characterization (i.e. identifying what pollutants are expected to be discharged) as part of the permit application. The Application for Individual NPDES Permit Associated with Mining Activities (5600-PM-BMP0032) includes effluent characterization requirements in Section D. The goal of effluent characterization is to assure that the nature and quantity of pollutants in the effluent, as well as their effect on the receiving waters, is fully evaluated during the application review and permit development process.

Resources are available to assist both the applicant to determine if a pollutant should be expected to be present in the effluent and the Department in reviewing this information. These resources include:

- The “Development Document for Effluent Limitations Guidelines and Standards for the Coal Mining Point Source Category” (US EPA, 1982),
- Data from adjacent or similar sites,
- Datasets collected by the U.S. Geological Survey (USGS) as part of a survey of coal mine discharge characteristics in Pennsylvania, and
- Data collected by the Pennsylvania Coal Alliance and the Pennsylvania Aggregates and Concrete Association.

The pollutants for which sampling may be required are listed in various categories in Appendix D of 40 CFR Part 122. For new discharges, the applicant can predict the expected effluent using nearby existing discharges that are comparable to the anticipated new discharge. For example, discharges from other nearby and similar mining operations on the same coal seams can be used to characterize the expected water quality from the new discharge. The wastewater characterization must address all of the pollutants reasonably expected to be present in the discharge. These pollutants are identified in 40 CFR 122.21(k), and the tables in Appendix D to 40 CFR Part 122. The application must also identify the expected discharge (flow) volume.

Upon issuance of the permit, the permittee must sample the treated effluent from each discharge for the above pollutants within two years of when the discharge starts. This sampling will be used to determine the accuracy of the initial

discharge characterization. For renewal of existing permits, this sampling should be used for a review of effluent characterization.

Under Section 402(k) of the Clean Water Act, 42 U.S.C § 1342(k), an NPDES permit provides authorization and a shield for the discharge of the following pollutants resulting from facility processes, waste streams and/or operations at specified outfalls that have been clearly identified in the permit.:

- Pollutants specifically limited in the permit or pollutants which the permit, fact sheet or administrative record explicitly identify as controlled through indicator parameters,
- Pollutants for which the permit authority has not established limits or other permit conditions, but which are specifically identified in writing as present in facility discharges during the permit application process and contained in the administrative record which is available to the public, and
- Pollutants not identified as present but for which constituents or waste streams, operations or processes were clearly identified in writing during the permit application process and contained in the administrative record which is available to the public.

5.1.6 Reasonable Potential Analysis

For new discharges and upon NPDES renewal, the Department must conduct a reasonable potential analysis (RPA) for each discharge. This analysis must consider all factors or parameters that may cause or contribute to an excursion of in-stream criteria. There are various ways to determine if there is a reasonable potential for a discharge to cause or contribute to a violation of the in-stream limits. If any of these approaches conclude that there is a reasonable potential, the permit will include appropriate WQBELs. Any parameters that have potential to cause an exceedance must have an effluent limit. Common parameters that could potentially result in additional effluent limitations may include osmotic pressure, total dissolved solids (TDS), sulfate (SO₄), chloride (Cl), and selenium (Se), depending on overburden characteristics, alkaline addition, depth of mining, flow, and water quality of the receiving stream. The Department will develop a draft NPDES permit, including proposed effluent limits, which is then published in the *Pennsylvania Bulletin* for comment by the applicant and the public. More information on setting effluent limits can be found in the Department's technical guidance "Developing National Pollutant Discharge Elimination System (NPDES) Permits for Mining Activities" (563-2112-115).

5.1.7 Total Maximum Daily Load (TMDL)

Streams that are impaired for one or more water quality standard are placed on the Department's 303(d) list of impaired waters. For these streams or stream segments, the Department must determine the TMDL necessary to implement the applicable water quality standards. A TMDL assigns waste load allocations

(WLAs) to all permitted discharges and the WLA is the loading allocated to existing and future point sources. A point source discharge is a pollutant source regulated under the NPDES permit system. The TMDL development process results in a TMDL document which defines the maximum allowable daily load for discharges. When a new discharge is proposed in a watershed with an approved TMDL, the discharge must comply with the maximum load mandated by the TMDL, in addition to BAT. WLAs serve as the basis for developing WQBELs. Waste load allocations can be obtained in several ways:

- Using an assigned WLA built into the TMDL.
- Reassignment of WLAs from reclaimed operations that are no longer needed by that operation.
- Showing an offset from other pollution sources that will be abated by the permittee (demonstrating an offset can be time consuming and complex).

If no WLA is available, then the permit applicant may employ a non-discharge alternative or discharge at in-stream criteria, depending upon the pollutant in question. If a non-discharge alternative is used, a pre-treatment standard of BAT and any WQBEL will be applied to any water to be handled.

In many existing TMDLs, a typical WLA for precipitation-induced discharges of iron (Fe), manganese (Mn), and aluminum (Al) at BAT effluent limits is based on a 40-acre operational area. Smaller or larger operational areas would require proportionally smaller or larger WLAs in order to discharge at the same effluent limits. For example, a surface mine with an 80 acre operational area might require reassignment of two WLAs from reclaimed surface mines that had 40-acre operational area. TMDLs are watershed specific, so therefore it is important to review the TMDL for the specific watershed of concern.

For remining operations, Title 25, Chapter 87, Subchapter F (Subchapter G in anthracite regulations) discharge points are not subject to WLAs because the pollution is counted as part of the nonpoint source Load Allocation (LA) rather than the point source WLA. Therefore, Subchapter F/G discharges do not generally require a WLA. In addition, there is a presumption that the remining operation will ultimately reduce the pre-remining pollution load. If for some reason the Subchapter F/G discharge exceeds the pre-remining baseline, then any additional pollution load may be subject to TMDL limits. See the Department's remining regulations at 25 Pa. Code §§ 87.207 and § 88.507.

5.1.8 *Manganese*

Certain provisions of the regulations allow for the exemption of manganese limits. Specifically, 25 Pa. Code §§ 87.102(c)(2) and 88.92(c)(2) exempt manganese if the raw water without treatment has a pH greater than 6.0 and iron less than 10 mg/l. Similarly, 25 Pa. Code § 87.102(e) does not require a manganese limit. A manganese limit is still required if the discharge may cause in-stream

manganese to exceed the Chapter 93 water quality criterion of 1.0 mg/l or if the receiving stream has a TMDL-based manganese limit.

5.2 Antidegradation Analysis

Chapter 93 of Title 25 of the Pennsylvania Code provides for the protection of water uses. Water uses, described in sections 93.3 and 93.4, include quality life, water supplies, recreation and fish consumption, and special protection water uses.

Pennsylvania's antidegradation regulations at 25 Pa. Code § 93.4a(b) require that existing instream water uses and the level of water quality necessary to protect the existing uses shall be maintained and protected. For streams that are High Quality Waters (HQ) or Exceptional Value Waters (EV), referred to as "special protection waters," the Department is required to protect the existing water quality of those waters. In addition, the Department will ensure protection of federal or state threatened and endangered species and their critical habitat in or on any surface water. The current classification of streams can be viewed on the Department's eMapPA tool.

In most instances, streams designated by the PFBC as Class A Wild Trout Streams also qualify as HQ waters. In addition to the antidegradation regulations, the bituminous and anthracite surface coal mining regulations (25 Pa. Code §§ 87.138 and 88.62) further require that the applicant identify fish and wildlife resources within the proposed permit area and adjacent areas as well as habitats of unusually high value and reproduction areas. These chapters require a Fish and Wildlife Protection and Enhancement Plan that describes the protective measures that the operator will use during the active mining phase and the enhancement measures that will be used during the reclamation and post-mining phase.

The Department, with input from the Pennsylvania Fish and Boat Commission, considers streams that support naturally reproducing trout as one example of a resource that requires the added protection and enhancement of the regulations noted above. The Department recommends that the protection and enhancement plans incorporate additional erosion and sedimentation control measures, which include but are not limited to sediment impoundment capacities of 8,600 ft³/ac and the appropriate Antidegradation Best Available Combination of Technologies (ABACT) measures identified for mining in Appendix D of the Department's guidance document "Water Quality Antidegradation Implementation Guidance" (391-0300-002).

Chapter 93 requires that a permit applicant proposing a new, increased or additional discharge to Special Protection waters shall first evaluate non-discharge alternatives as part of an antidegradation analysis. Non-discharge alternatives must be implemented if they are environmentally sound and cost-effective. Non-discharge alternatives that could be used on surface mine sites include, alternative project siting, discharging to a non-special protection watershed, infiltration galleries or land application, injection, recycling/reuse of water onsite.

If all discharges of surface water, treatment water, and groundwater can be addressed without creating a discharge to a surface water (e.g. non-discharge alternatives), then the

permit review can continue. If not all the discharges can be addressed by non-discharge alternatives, then the applicant must demonstrate that the discharge will maintain and protect the existing quality of the receiving streams by using Antidegradation Best Available Combination of Technologies (ABACT). These technologies must be identified in the permit application.

If, after completing the demonstration for ABACT/BMPs, the ABACT/BMPs are not sufficient to protect the existing surface water quality and the receiving water is a HQ Water, the application may complete the portion of the permit application relating to Social or Economic Justification (SEJ). If the receiving water is EV, then the permit review will not proceed. In HQ Waters only, the Department may allow a reduction in water quality if it finds, after satisfaction of intergovernmental coordination and public participation requirements, that allowing lower water quality is necessary to accommodate important economic or social development in the area in which the waters are located. The mining program implements the review of proposals in special protection watersheds by using the Antidegradation Supplement for Mining Permits (5600-PM-BMP0007).

5.2.1 Antidegradation Analysis

An antidegradation analysis must be conducted for all proposed mining operations located within HQ or EV watersheds. “Antidegradation Supplement for Mining Permits” (5600-PM-BMP0007) must be used in all cases where a mining operation is proposed in a special protection watershed.

Pre-application discussions are required. It is recommended that a meeting be held with the Technical Services Chief of the appropriate district mining office to discuss the proposed non-discharge alternatives evaluation. Section 1 of the Antidegradation Supplement must be completed and reviewed by the Department prior to completing Section 2. If non-discharge alternatives will be used to address all potential discharges from the proposed mining operation, Section 2 of the Antidegradation Supplement does not need to be completed. The implementation of the non-discharge alternatives must be described in the E&SCP of the mining permit application and in the NPDES permit application. However, any discharges not addressed by non-discharge alternatives must be addressed in Section 2.

The SEJ or Water Use Demonstration Form (5600-PM-MR0028) should only be completed after the Department has concluded its review of the Antidegradation Supplement for Mining Permits and confirmed that an SEJ was necessary. The SEJ request should be detailed and inclusive and not refer to other parts of the application. The SEJ request will be evaluated by the Department and the applicant will be informed of the Department’s decision.

5.2.2 Non-Discharge Alternatives Evaluation

Environmentally sound and cost-effective alternatives must be used to eliminate or reduce new, increased, or additional point source discharges to HQ or EV

FOR DISCUSSION PURPOSES ONLY (AGGREGATE ADVISORY BOARD)

waters. Non-discharge alternatives may also be employed in impaired streams where no waste load allocation is available. Potential non-discharge alternatives for mining operations are as follows:

- a) Alternative project siting (in whole or in part): This alternative is generally not feasible for mining projects since the coal or mineral to be mined cannot be relocated outside the special protection watershed.
- b) Alternative discharge locations/discharging to another (non-special protection) watershed: This alternative could be used for mining operations where the proposed mine site is located near or on the boundary of a non-special protection watershed. The proposed discharge(s) could be conveyed outside of the HQ or EV watershed.
- c) Infiltration - galleries or land application: Although infiltration or land application of treated water from mine sites can be feasible at some mine sites, its use should be limited to sites with minimal discharge quantities and suitable soil and geologic conditions. The Department's guidance document "Manual for Land Application of Treated Sewage and Industrial Wastewater" (362-2000-009) should be consulted for further guidance when evaluating an infiltration system alternative.
- d) Limiting disturbed area (vertically or horizontally), extent and/or duration of mining: Limiting of disturbed area is feasible and encouraged on most mine sites and is strongly recommended on sites within special protection watersheds. Prompt backfilling and reclamation of mine pits is also recommended to prevent the generation of acidic mine drainage.
- e) Recycling/reuse of water onsite: Water collected in sediment basins and traps can be used for dust control on haul roads and stockpile areas to reduce the volume of water that is discharged from the mine site.
- f) Constructed treatment wetlands: Although they are more commonly used on reclaimed or abandoned sites, passive treatment wetland systems could be used to provide additional treatment of discharges from active mining operations.
- g) Holding facilities and/or wastewater hauling: Due to the potential for large quantities of surface water runoff at most mine sites, this alternative is usually not a feasible option. It may be feasible for certain small noncoal operations where all of the runoff is contained within the mine pit.
- i) Injection: Deep well injection is an alternative that can be used for mining operations. It has been shown to be feasible for certain long-term industrial mineral operations located in areas with the appropriate geologic conditions. Two permits are required before a disposal well may be constructed and operated. A well permit under the Pennsylvania 2012 Oil

and Gas Act and an Underground Injection Control (UIC) permit from the United States Environmental Protection Agency (EPA).

- j) Vegetated riparian buffers: Coal and industrial mineral surface mining activities are required to maintain a minimum 100-foot buffer along perennial and intermittent streams. In HQ or EV watersheds, stream variances to the 100-foot buffer are only permitted if the proposed mining activity will result in an environmental enhancement or for minor activities such as channels or stream crossings. Stream channels in HQ or EV watersheds may not be relocated to accommodate mining activities unless the relocation results in environmental improvement.
- k) Specific pollution prevention processes: Examples of pollution prevention alternatives for mining operations include alkaline addition plans and overburden special handling plans that prevent the generation of acidic mine drainage. For further guidance on alkaline addition, refer to the Department's guidance document "Alkaline Addition for Surface Coal Mines" (563-2112-217).
- l) Other(s): The Department will review and consider additional alternatives that are proposed by the applicant.

If none of the above alternatives either by themselves or in combination, eliminate all discharges from the proposed mine site, the applicant must provide documentation of the feasibility analysis and cost data as justification. Refer to Chapter 7 of the Department's guidance document "Water Quality Antidegradation Implementation Guidance" (391-0300-002) for a description of how to evaluate the cost-effectiveness of non-discharge alternatives.

5.2.3 *Discharges from Emergency Spillways*

During storm events larger than the design storm capacity of the basin, there may be a stormwater discharge from a sediment basin emergency spillway in spite of the fact that the permit was written as a non-discharge permit. In these cases, the applicant may do an analysis that compares the water quality of the emergency spillway discharge with the water quality of the receiving stream. If it can be clearly demonstrated that the emergency spillway discharge would be of better water quality than the receiving stream, then the discharge could be considered as non-degrading. Otherwise, sediment basins must have a sufficiently large capacity to prevent any potentially degrading discharge from the emergency spillway.

5.3 **Point Source Discharges ABACT and SEJ Analysis in Special Protection Watersheds**

If a point source discharge is anticipated, then the applicant must complete Section 2 of the Antidegradation Supplement. In Section 2 of the supplement, the applicant must demonstrate that the resulting discharges will maintain and protect the existing quality of

the HQ or EV waters. Using existing monitoring data, the applicant must calculate the required effluent limits, through a mass balance, for the discharge to be non-degrading. Refer to Chapter 8 of the Department's guidance document "Water Quality Antidegradation Implementation" (391-0300-002) (WQAIG) for a description of the Department's Test for Non-Degradation of Water Quality. The applicant must also identify the combination of Best Management Practices (BMPs) that will be used during the proposed mining operation to achieve a non-degrading discharge. Part B of the Antidegradation Supplement lists 20 BMPs that may be used. The critical question is whether the ABACT BMPs are sufficient to protect the existing surface water quality. If the answer is yes, then the project review may proceed; if the answer is no, and the project is located in a HQ watershed, then an SEJ may be submitted. If the answer is no, and the project is located in an EV watershed, the project cannot proceed.

If, after evaluating ABACT, the applicant cannot demonstrate it will have a non-degrading discharge, then the applicant may submit a SEJ and demonstrate that the resulting discharges to HQ Waters are necessary to accommodate important economic or social development in the area in which the waters are located and that a reduction in water quality will support applicable existing and designated uses in 25 Pa. Code § 93.3, Table 1. The "*Social or Economic Justification and Water Use Demonstration Application /5600-PM-BMP0028*" should only be completed after the Department has completed its review of the Antidegradation Supplement for Mining Permits and confirmed that an SEJ is necessary. The SEJ request should be detailed and inclusive and not refer to other parts of the application. The SEJ request will be evaluated by the Department and the applicant will be informed of the Department's decision by letter. Figures 5.1 and 5.2 are flow charts detailing the permit review process for discharges for special protection watersheds.

Figure 5.1.
Generalized Permit Review Process for Proposed Discharges to HQ Waters

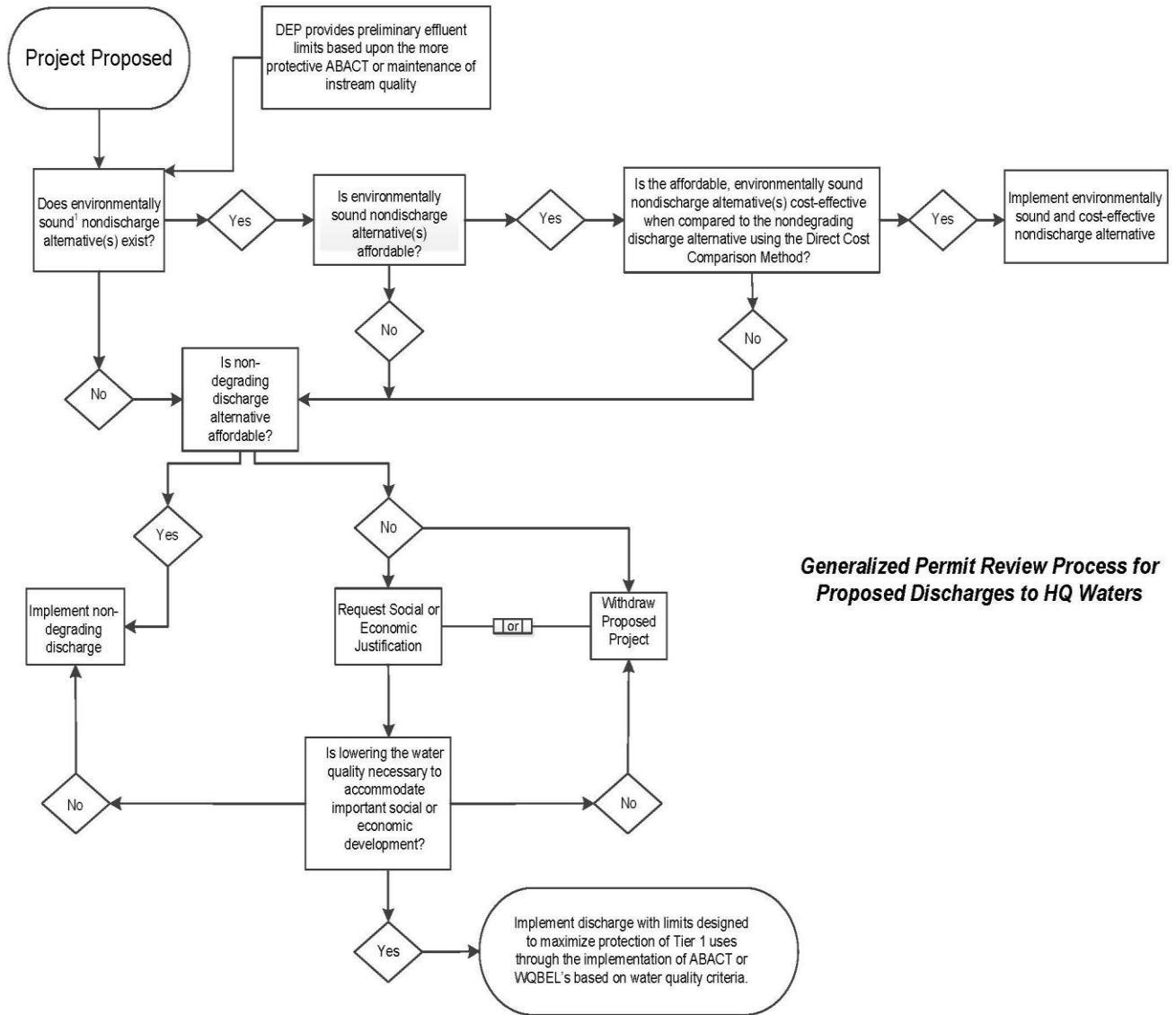

1 - Alternative produces more environmental benefits than harm.

Figure 5.2.
Generalized Permit Review Process for Proposed Discharges to EV Waters

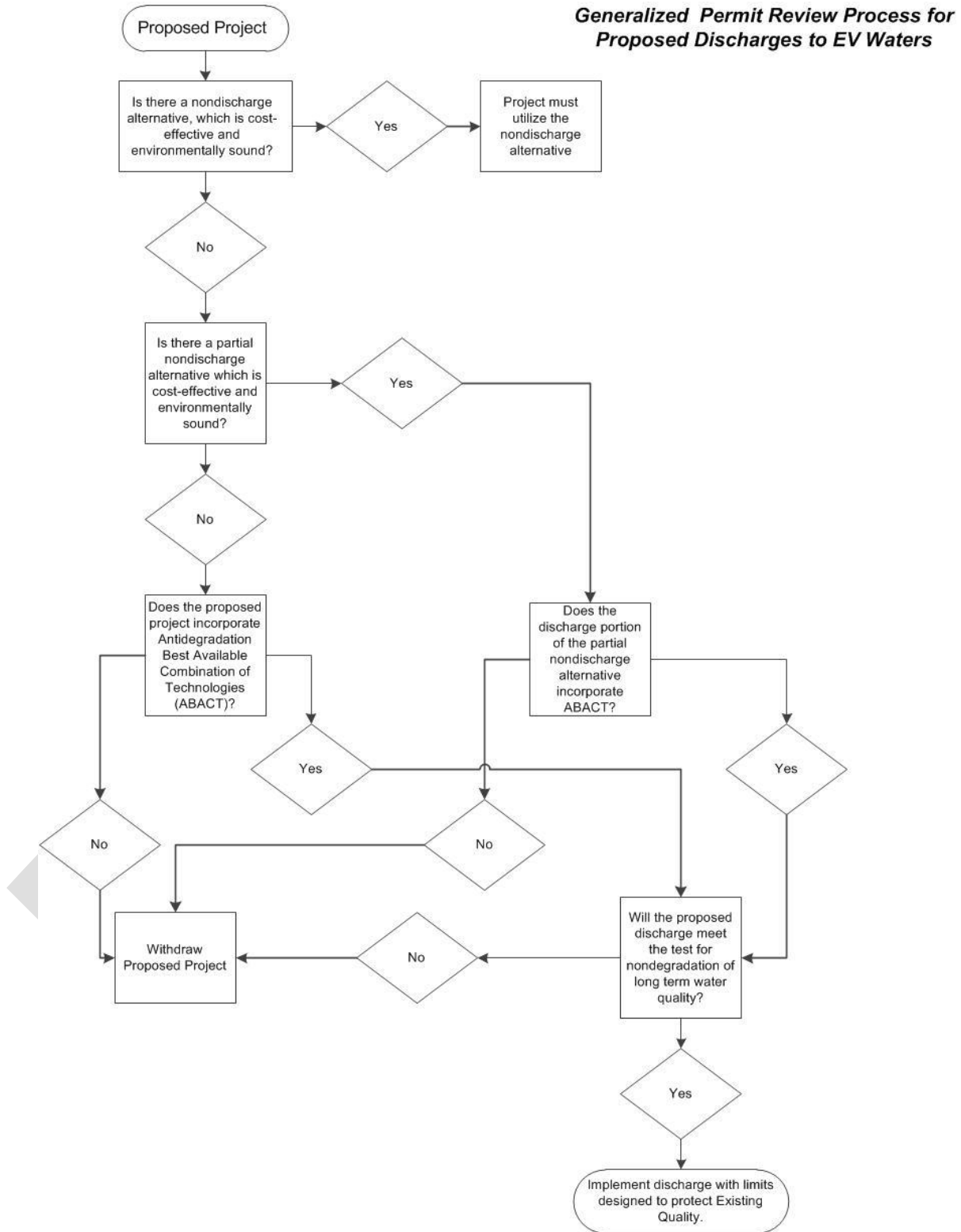

5.4 Infiltration: Galleries or Land Application

Under appropriate circumstances, infiltration systems may qualify as non-discharge alternatives for mine sites in special protection watersheds or on impaired streams that do not have an available Waste Load Allocation. These systems must be designed to prevent a discharge to surface water, especially to Special Protection waters or impaired streams. Sample ports are required on the outlets of sedimentation ponds to verify compliance. In addition, treatment ponds are sampled when infiltrating to verify compliance.

Choosing the appropriate infiltration system for a proposed mine site depends on many factors. These factors include:

- Quality and classification of the receiving stream,
- Distance from infiltration area to the stream,
- Expected life of mining operation,
- Size of drainage area to the sediment pond or pumping rate to treatment pond,
- Distance to private wells or on-lot sewage systems,
- Seasonal operational schedule of mining operation, and
- Soil type and condition in infiltration area.

5.4.1 Site Evaluation and Soil Infiltration Testing

A thorough investigation of the proposed infiltration area is the first step in the design of the infiltration system. The soil type and condition need to be determined at the outset. Published data from the NRCS county soil surveys, or soil maps obtained from The Pennsylvania State University may be used to provide the necessary soil types and infiltration rates. In this case, the lower end of the range of infiltration rates given by the NRCS manual should be used. Site specific soil type and infiltration rate data may be required by the Department or provided by the applicant depending on site factors such as watershed designation, location, local geology, topography, expected life of mining, etc. This may require a qualified soil professional to determine soil types and infiltration rates and provide the required data needed to design the system. This requirement is at the discretion of reviewing mining office.

The investigation should start with a review of published literature and online information concerning soil types and infiltration rates. Next, a site investigation of the proposed infiltration area is conducted to look for any limiting factors, such as previous disturbance, sinkholes, rock outcrops, or conditions in conflict with the published data. The next step is to determine the infiltration rate, either

through on-site infiltration testing or through a literature review, depending on the factors listed above.

There are two types of infiltration systems: surface and subsurface. Examples of surface infiltration systems include perforated pipe level spreaders, level pipes with perpendicular perforated pipes, infiltration basins, and spray irrigation systems. Examples of subsurface systems include infiltration beds, similar to a sewage leach field, and infiltration trenches. Regardless of the system chosen, there must be a valve at the pond outlet to regulate flow and a sampling port to assure that only water in compliance is released to the infiltration system

After the infiltration rate has been determined, a certain percentage of that rate should be used for design purposes. Fifty percent is usually the starting point, to account for variable antecedent conditions, but if site conditions or usage conditions warrant, then a lesser value, should be used.

5.4.2 *Surface Infiltration Systems*

Most surface infiltration systems on mine sites are either the perforated pipe level spreaders (Figure 5.3) or a level manifold with perpendicular perforated pipes (Figure 5.4). Both systems rely on many small holes discharging water at a rate that will infiltrate into the soil, rather than create surface flow. Detailed drawings and cross-sections of the proposed infiltration systems must be submitted along with supporting design calculations.

The calculations involve the infiltration rate and the amount of water to be removed from the pond over the dewatering time. The infiltration rate is usually expressed as inches/hour, and the dewatering rate can be determined from the settling volume of the pond divided by four days for special protection watersheds or six days for non-special protection watersheds.

- $\text{In/hr.} \times (\text{Conv. Factor}) = \text{gal/min/ft}^2$
- $\text{Dewatering volume}/4 \text{ days} \times (\text{Conv. Factor}) = \text{gal/min}$
- $\text{Dewatering volume}/\text{infiltration rate} = \text{ft}^2 \text{ of infiltration area required}$

The following items should be addressed when designing the proposed system:

- The system must be adequately sized to infiltrate the expected flows. For sedimentation ponds, the system must be able to dewater the basin within 4-7 days of the storm event; for treatment ponds, the system must be able to handle the flow from the pit pump.
- A valve and sampling port or tap must be placed between the pond-dewatering pipe and the inlet to the infiltration system. The valve may not be opened until the pond water meets the applicable limits.

FOR DISCUSSION PURPOSES ONLY (AGGREGATE ADVISORY BOARD)

- The level spreader pipe or manifold pipe must be installed level and securely fastened in place.
- The natural soils may not be disturbed. No excavation, disturbance, or compaction of soils should be allowed in the proposed infiltration area.
- The infiltration area should have a 10 percent or flatter slope.
- Disturbance of the existing vegetation within the infiltration area should be restricted to the amount necessary to install the system.
- The pipe network may be covered with clean stone to protect it.
- The infiltration system must not be used when the ground within the infiltration area is frozen or saturated.

Figure 5.3.
Perforated Pipe Level Spreader

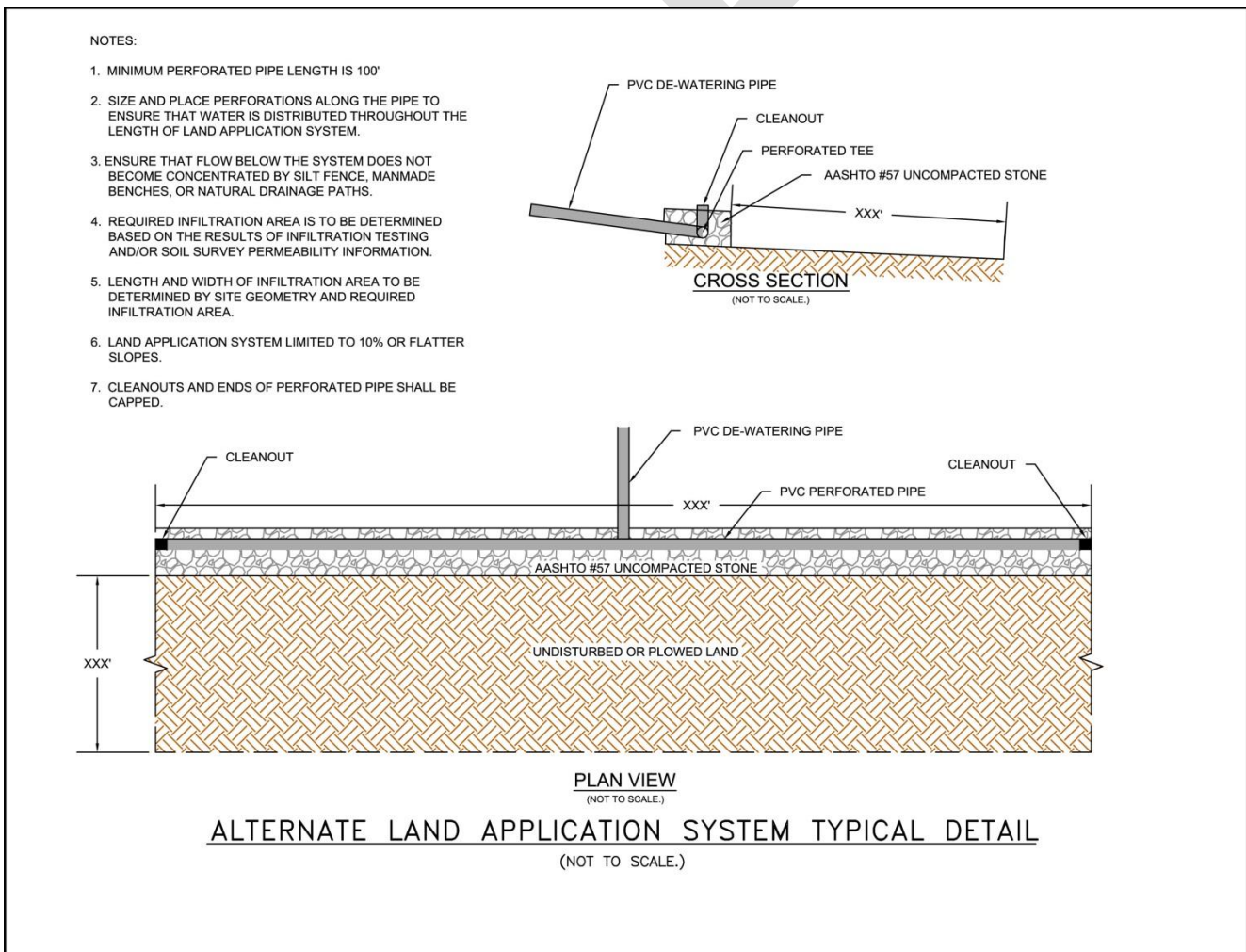
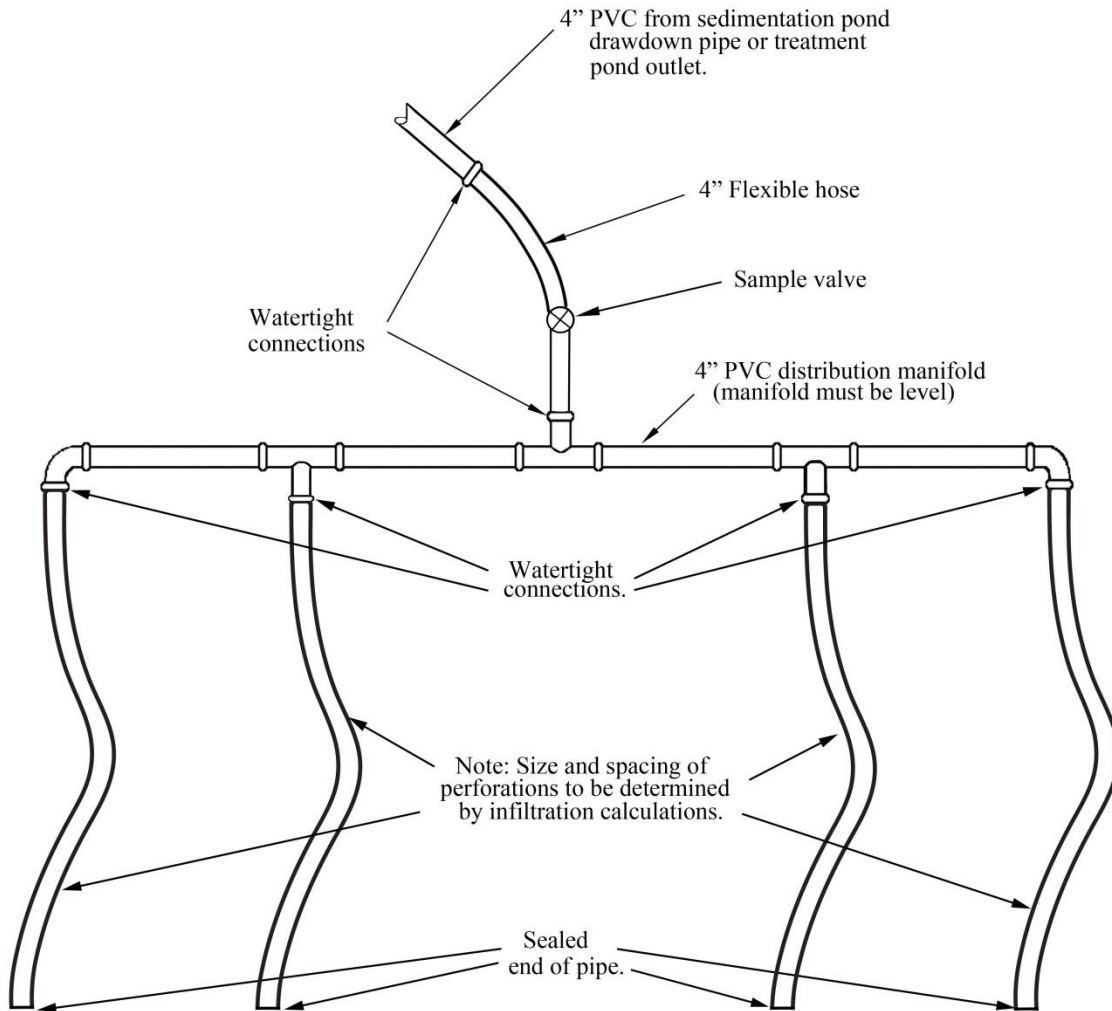

Figure 5.4.
Level Manifold with Perpendicular Perforated Pipes

Sedimentation Pond / Treatment Basin
Discharge Manifold

NOT TO SCALE



5.4.3 Subsurface Infiltration Systems

Infiltration trenches and infiltration fields (parallel trenches) require an area where trenches with level bottoms can be excavated. These trenches are usually from 4.0 to 10.0 feet wide, within the soil profile tested. The perforated pipe is set in crushed stone (#3 or larger) in the middle of the top of the excavated trench. Crushed stone may be placed over the perforated pipe for protection. Detailed drawings and cross-sections of the proposed infiltration systems must be submitted along with supporting design calculations (Figure 5.5).

Figure 5.5.
Infiltration Trench (PADEP Stormwater Best Management Practices Manual)

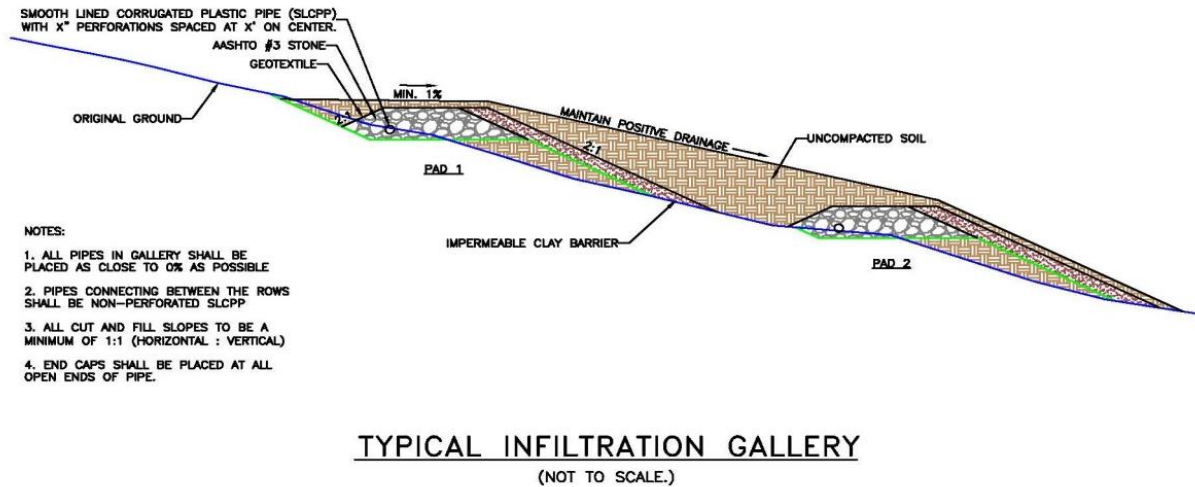

The calculations involve the infiltration rate and the amount of water to be removed from the pond over the dewatering time. The infiltration area is the area of the bottom of the trench. The infiltration rate can be determined by using one of the methods in the Department's guidance document "Stormwater Best Management Practices Manual," Appendix C (363-0300-002), and is usually expressed as in/hr. The dewatering rate can be determined from the settling volume of the pond divided by 4 days (from the 4-7 day dewatering guideline) or the pumping rate.

- $\text{in/hr} \times (\text{Conv. Factor}) = \text{gal/min/ft}^2$
- $\text{Dewatering volume}/4 \text{ days} \times (\text{Conv. Factor}) = \text{gal/min}$
- $\text{Dewatering volume}/\text{infiltration rate} = \text{sq feet of trench bottom required}$

The following items must be addressed when designing a subsurface infiltration system:

- The system must be adequately sized to infiltrate the expected flows. For sedimentation ponds, the system must be able to dewater the basin within four to seven days of the storm event;
- For treatment ponds, the system must be able to infiltrate the flow from the pit pump.
- A valve and sampling port or tap must be placed between the pond-dewatering pipe and the inlet to the infiltration system. The valve may not be opened until the pond water meets the applicable limits.

FOR DISCUSSION PURPOSES ONLY (AGGREGATE ADVISORY BOARD)

- For systems with multiple trenches, a manifold system must be installed to distribute the flow evenly to all the trenches.
- The area surrounding the infiltration trenches must be protected from compaction both during and after installation of the system.
- The trenches must be wrapped in suitable nonwoven geotextile to prevent fines from entering and plugging the stone fill.
- Pipe cleanouts should be placed on each end of the lateral trenches.
- The trench installation (Figure 5.6. Infiltration Trench) should be documented by the registered engineer and discussed in the notes on the back of the pond certification form.
- The system should be tested as soon as possible after installation to assure satisfactory performance.

Figure 5.7 is an aerial view of a noncoal operation with a sedimentation pond and subsurface infiltration gallery.

Figure 5.6.
Infiltration Trench (PADEP Stormwater Best Management Practices Manual)



Figure 5.7.
Limestone Quarry Subsurface Infiltration Gallery and Pond (Aerial View)



5.4.4 Typical Sample Calculation: Absorption Area Sizing for Sediment Ponds and Treatment Facilities

GIVEN: A typical Pennsylvania sediment pond has a maximum dewatering rate of $0.41 \text{ ft}^3/\text{sec}$. It is proposed to infiltrate this flow into an undisturbed area of Atkins Silt Loam (At) soil immediately below the construction zone of the pond with a soil infiltration rate of 0.5 in/hr .

FIND: Calculate the AREA of absorption necessary to safely disperse the maximum dewatering flow rate from the sediment pond.

SOLUTION: Infiltration Rate Atkins Silt Loam = $0.5 \text{ in/hr} \times 1.0 \text{ feet}/12 \text{ in} = 0.04167 \text{ feet/hr}$

(1 acre = $43,560 \text{ ft}^2$)

Absorption Rate Soil Field = $0.04167 \text{ feet/hr} \times 43,560 \text{ ft}^2/\text{acre} = 1,815.1452 \text{ ft}^3/\text{acre-hr}$

Maximum Dewatering Rate Pond = $0.41 \text{ ft}^3/\text{sec} \times 60 \text{ sec/min} \times 60 \text{ min/hr} = 1,476 \text{ ft}^3/\text{hr}$

Area Absorption required = $\frac{\text{Maximum Dewatering Rate Pond (ft}^3/\text{hr)}}{\text{Absorption Rate Soil Field (ft}^3/\text{Acre-hr)}}$

AREA ABSORPTION required:

$$\frac{1,476 \text{ ft}^3/\text{hr}}{1,815.1452 \text{ ft}^3/\text{acre-hr}} = 0.81 \text{ acre} = \underline{35,421 \text{ ft}^2}$$

Typical length to width ratio: Length = (4) x (Width)
Length of the absorption area runs parallel to the pond embankment toe
If the Width = 95 feet, then the Length = 95 feet x (4) = 380 feet

Area Absorption-Design = Length x Width = 380 feet x 95 feet = 36,100 ft²

If the Design Area (36,100 ft²) is greater than the Absorption Area required (35,421 ft²), then the Absorption Area Design Dimensions are acceptable.

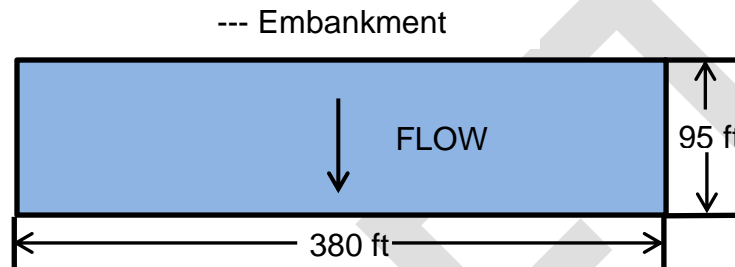

Absorption Area Dimensions: 380 feet x

6.0 MINE DRAINAGE TREATMENT – ACTIVE MINING

6.1 General Requirements (25 Pa. Code §§ 77.526, 87.101, 87.102, 87.107, 88.91, 88.92, 88.97)

The purpose of treatment ponds used during active mining is to treat water removed from the pit or coal-handling areas to the standards specified in the permit and then discharge it either to the receiving stream or into the groundwater. Surface mining activities should be planned and conducted to prevent, to the maximum extent practical, the accumulation of water in the pit. Limiting surface water is done through upslope diversions and temporary diversions on the sides of the pit. All groundwater or surface runoff encountered must be collected and pumped to an appropriate treatment system. The type and size of the treatment system depends on the anticipated water quality and quantity. Pre-mining water sampling should provide a good estimate of treatment requirements. Department regulations prohibit the discharge of pit water by gravity drains. Under no circumstance shall an operator drill, disrupt or blast the pit floor to avoid treating pit or surface water.

Most of the potentially toxic-forming materials are found in and adjacent to the coal seam. A timely removal of the coal and backfilling of the site can reduce the potential for Acid Mine Drainage (AMD) production.

For runoff water that has had contact with coal stockpiles, coal preparation areas, or acid producing spoil (contact water), please see Chapter 3 - Sediment Control Impoundments in this guidance.

6.2 Treatment Processes and Reagent Selection

The first step in designing a treatment system is to characterize the water to be treated in terms of chemistry (acidity, alkalinity, metals, sulfates, etc.) and suspended solids. This information will assist the Department in determining the length of detention time, level or aeration and types of chemical reagents that are required to treat the affected water. The Department recommends two ponds in series, each with a six-hour detention time. In some instances, the volume of the pond should be increased for slower chemical reactions, longer settling times, or higher pumping rates.

6.2.1 Alkaline Mine Drainage

Alkaline mine drainage is characterized by high metals and a pH above 7.0. The treatment of alkaline mine drainage requires vigorous aeration, which oxidizes the ferrous iron to ferric iron, and a settling time that will allow the iron to settle out. If there is enough natural elevation change on site, then aeration can usually be accomplished in a channel with adequately sized riprap or splash blocks or by spraying the water through a nozzle. Oxidation can also be accomplished by other mechanical means or through the addition of oxidizing chemicals.

Settling of the ferric iron is usually accomplished in flat-bottomed ponds, with depths of three to four feet. These ponds should be designed to provide several

days of settling time and have adequate volume for sludge storage. A cleaning schedule should be estimated along with a non-polluting disposal site. Plug flow through the ponds should be established at the inlet. The outlet should be a level weir with a low velocity.

6.2.2 Acid Mine Drainage

Acid Mine Drainage is an acidic water (pH <5.0), loaded with iron, sulfate and other metals, that forms under natural conditions when geologic strata containing sulfide minerals are exposed to the atmosphere or oxidizing environments. The technology employed for the treatment for this form of mine drainage includes pH adjustment, chemical precipitation, aeration and settling. The first step in the process consists of the addition of an alkaline reagent to raise the pH. The increase in pH causes the solubility of the metal ions to decrease and precipitate out of solution. These metal ions are replaced in solution by more acceptable calcium, magnesium, and sodium ions (EPA, 1982). In general, three types of reactions occur as a result of pH adjustments:

- Neutralization: an ion exchange reaction that, for AMD, combines basic hydroxyl ions with acidic hydronium ions,
- Oxidation: which, for example, converts ferrous iron (Fe^{2+}) to ferric iron (Fe^{3+}), and
- Precipitation: which results from solubility decreases of metal ions.

The precipitates are in most cases metal hydroxides such as ferric hydroxide ($\text{Fe}(\text{OH})_3$) which can be removed to a great extent by settling (EPA 1982).

Several alkaline reagents are used to neutralize acidic pit water and acid mine drainage. The different reagents can be divided into two main groups, the sodium compounds and the calcium compounds. The calcium compounds include hydrated lime (calcium hydroxide, $\text{Ca}(\text{OH})_2$); limestone (calcium carbonate, CaCO_3) and quicklime (calcium oxide, CaO). The sodium compounds include caustic soda (sodium hydroxide, NaOH), and soda ash (sodium carbonate, Na_2CO_3). Reagents are chosen depending on the quality and volume of water to be treated and the amount of maintenance required for each neutralizing agent and treatment system.

6.2.3 Calcium versus Sodium

The calcium compounds are less expensive than sodium compounds, but they have lower solubility in water. Therefore, calcium compounds are generally used in large treatment systems where electricity is available to improve the reactivity of the calcium material through mixing. If sulfate concentrations are above 2,000 mg/L, then the calcium products will react with the sulfate to form anhydrite or insoluble gypsum. This calcium sulfate (CaSO_4) precipitate may

clog pipes or other structures used to convey the water to the receiving stream after treatment and discharge. (Skousen, 1990).

6.2.4 Carbonate versus Hydroxide

The pH of the water during treatment affects the types and amounts of metals that can be removed or precipitated from the water. Carbonate compounds do not raise pH of the water above 8.5, while hydroxide compounds can raise pH above 10.0. Ferric iron (Fe³⁺) converts to the solid yellowish-orange precipitate ferric hydroxide, also referred to as “yellow boy,” at a pH of 3.5 or greater. Ferrous iron (Fe²⁺) converts to the solid bluish-green ferrous hydroxide at a pH of 8.5 or greater. Soluble manganese (Mn²⁺) changes to insoluble manganese dioxide (MnO₂) at a pH of 10.0. Therefore, the various metal concentrations in the AMD dictate the appropriate chemical reagent to be used to achieve sufficiently high pH levels. If ferric iron (Fe³⁺) is the major problem, it is possible to remove it with sodium carbonate, while manganese generally requires the elevated pH attained by adding a hydroxide material. If ferrous iron is present, a sodium hydroxide material may be used, but it may be cost-effective to use hydrated lime in conjunction with an aerator to oxidize the ferrous to ferric iron for precipitation at a lower pH (Skousen, 1989). See Table 6.1.

Table 6.1: Factors that may Influence the Selection of a Calcium or Sodium Compound for an AMD Treatment System

Factor	Calcium Compounds	Sodium Compounds
Solubility	Slow, less soluble	Fast, more soluble
Application	Requires mixing	Diffuses well
Hardness	High	Low
Gypsum Formation	Yes	No
High Total Suspended Solids	Helps settle clay	Disperses and keeps clay particles in suspension
Chemical Cost	Lower	Higher
Installation & Maintenance Costs	High	Low

6.2.5 Hydrated Lime

Hydrated lime (calcium hydroxide) is the most commonly used reagent and reacts with AMD as shown by the following equation:

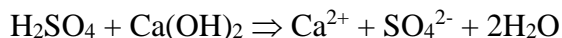

Hydrated lime can be introduced dry or as an aqueous solution. One pound of sulfuric acid needs 0.76 lbs of calcium hydroxide for neutralization. Skousen

(1989) reports that when neutralizing large amounts of AMD with high acidity levels for long periods of time (greater than 3 years), a more capital intensive, but cheaper hydrated lime reagent is generally used. Hydrated lime treatment systems require a power source for mechanical mixing of the lime with the water and pH meters to control the application rate.

6.2.6 *Crushed Limestone*

Crushed limestone (calcium carbonate) reacts with AMD as shown by the following equation:

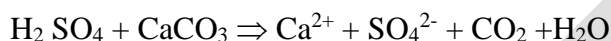

One pound of sulfuric acid requires 1.02 lbs of calcium carbonate for neutralization. Limestone is the cheapest reagent, but also has a limited solubility, a low reactivity at higher a pH and its use results in the formation of gypsum. Treatment of AMD with limestone can also be limited by iron coating of the larger limestone particles, which render the particles non-reactive. The efficiency of using pulverized limestone to treat AMD varies from 50 percent to 90 percent depending on the mixing method, particle size, aeration and settling characteristics (Lovell, 1973). Successful treatment with limestone usually involves the use of mixing equipment. The achievable pH ceiling for limestone treatment is approximately 7.5, which is insufficient to precipitate many metals, particularly manganese (EPA 1982). If only small concentrations of iron, manganese, and aluminum are found in the water, limestone can be utilized to precipitate these ions.

6.2.7 *Quicklime*

Quicklime (calcium oxide), also called burnt or pebble lime, reacts with AMD as shown by the following equation:



One pound of sulfuric acid requires 0.57 lbs of calcium oxide for neutralization. When sulfate concentrations are high (above 2,000 mg/L), the calcium products will react with the sulfate to form anhydrite or insoluble gypsum. This calcium sulfate precipitate may clog pipes or other structures used to convey the water to the receiving stream after treatment. Quicklime is not frequently used as equivalent results can be achieved with the similarly priced but easier to handle hydrated lime. Quicklime is extremely caustic and can cause severe damage to the skin, eyes, and respiratory tract.

6.2.8 *Caustic Soda*

Caustic soda (sodium hydroxide) is frequently used to treat AMD in situations where electrical power is not available. Because caustic soda is a hydroxide compound, it can be used to raise the pH of the water above 10.0 to facilitate

manganese precipitation. Caustic soda is a strong base, which mixes readily with and reacts with AMD as shown by the following equation:

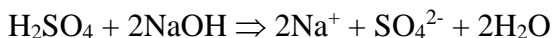

One pound of sulfuric acid requires 0.82 lbs of solid sodium hydroxide for neutralization. A 50 percent solution of caustic soda solidifies at 54 degrees Fahrenheit (EPA 1982). To reduce the freezing problem, a 20 percent solution is available. When using sodium hydroxide, protective eyeglasses, gloves, and clothing must be worn. A solution of 20 percent sodium hydroxide is particularly dangerous as it looks like water but can cause severe chemical burns and blindness. Because sodium hydroxide is such a strong base, close monitoring and control of the inflow and reagent is required to prevent over-treatment (EPA 1982). Treatment with sodium hydroxide produces a ferric hydroxide or “yellow-boy” sludge that is gel-like. Caustic soda solution is applied at the surface because the chemical moves downward into the water (Skousen, 1990).

6.2.9 Soda Ash

Soda ash (sodium carbonate) is frequently used to treat AMD discharges that are low in flow rate and acidity level. Soda ash reacts with sulfuric acid as shown by the following equation:



One pound of sulfuric acid needs 1.08 lbs of sodium carbonate or 0.40 gallons of 20 percent solution for neutralization. Soda ash can be added in the form of a slurry, but it is usually added by dissolving solid soda ash briquettes. A box or barrel is used to hold the briquettes with an inlet and outlet for the water to be treated. The water flows through the inlet of the container and dissolves the soda ash. Gravity keeps the briquettes in contact with the water for continual treatment (Skousen, 1990).

6.2.10 Reagent Selection

The level of pH elevation necessary for metal precipitation is an important criterion for the selection of an AMD treatment chemical. Carbonate compounds do not raise the pH of the water above 8.5, while hydroxide compounds can raise the pH above 10.0. Soluble manganese changes to insoluble manganese hydroxide at a pH of 10.0. Thus, calcium hydroxide and sodium hydroxide are suitable reagents when manganese is to be removed.

The selection of a treatment system and application method is based on the quantity of water to be treated, the use of a chemical that can adequately and economically treat the water, the detention time needed, and the mixing method. Unless power is available, the use of hydrated lime is not generally feasible. Soda ash and sodium hydroxide are soluble and can be utilized without mixing.

The volume of sludge from an AMD treatment system varies according to the chemical used and the quality of the untreated water. A precipitate consisting of mixtures of iron, manganese, and aluminum hydroxides is formed with any of the treatment chemicals used. When any of the calcium chemicals are used, a calcium sulfate or gypsum precipitate is also formed. The various lime treatment methods produce a greater quantity of sludge than the other treatment methods.

Another important consideration to consider is the safety of the treatment operator when using the chemicals. Limestone and sodium carbonate are relatively safe chemicals to use although they are not extremely effective neutralizers. The use of calcium hydroxide or calcium oxide can cause skin and eye irritation. Prolonged exposure will cause burns. When using sodium hydroxide or any reagent, protective eyeglasses, gloves, and clothing should be worn.

Prompt dewatering of pit water accumulations will decrease the amount of reagent required to treat the water

6.2.11 Aeration and Oxidation

Aeration increases the oxygen transfer rate and therefore the oxidation reaction rate. Aeration can be accomplished by allowing the water to simply flow or cascade down a staircase trough or sluiceway. Aeration is accomplished when water flows from one impoundment to the next. On larger discharges, the air or oxygen may be supplied by one of the following types of aerators: diffused air systems, submerged turbine aerators, and surface aerators (EPA 1982).

The oxidation system consists of a tank or basin equipped with one or more of the above aeration systems. The presence of dissolved oxygen supplied by the aerating technique oxidizes ferrous ions, thus enhancing the formation of essentially insoluble ferric hydroxide. The resulting sludge is more easily settled (EPA 1982). In special cases, oxidizing chemicals may be used when aeration through mechanical disturbance is not adequate or rapid enough. Chemicals, which are active oxidants, include hydrogen peroxide, potassium permanganate, sodium hypochlorite, calcium hypochlorite, and chlorine.

6.2.12 Settling

The settling, or sedimentation, process removes the suspended solids, which includes the insoluble precipitates. Sedimentation can be accomplished in a settling basin or a clarifier. The extent of solids removal depends on the surface area of the impoundment, flow patterns in the structure, detention time, and settling characteristics of the suspended solids. Clarifiers allow more control over detention time and sludge removal. In addition, problems from precipitation and short-circuiting can be avoided.

6.2.13 Flocculation

Chemical flocculation can be used to increase the efficiency of treatment basins, similar to their use in sedimentation impoundments (See Section 3.14, of this guidance). The colloidal particles in AMD sludge or turbid pit water usually carry a negative electrical charge. Consequently, a cationic flocculant must be used. Synthetic polyelectrolytes are most frequently employed since they function best in the high ionic strength solutions encountered in AMD.

6.2.14 Sludge

The quantity of sludge formed from AMD treatment varies according to the reagent used. All treatment methods produce a precipitate consisting of a mixture of iron, manganese, and aluminum hydroxide. The calcium chemicals (e.g., limestone, hydrated lime, and burnt lime) also generate calcium sulfate or gypsum, which constitutes part of the precipitate. Sodium hydroxide produces a gel-like sludge which is composed predominately of ferric hydroxide and which precipitates out in the settling ponds.

Sludge formed in the treatment process ranges from 1 percent to 10 percent of the total flow through the facility (Department of Interior/Office of Surface Mining, 1988). Once the amount of precipitate accumulates to the design cleanout level, the treatment pond must be drained and the sludge removed for final disposal. Normally the sludge is simply mixed with surface mine spoil material at a location relatively high and dry in the backfill area during the reclamation process. This sludge is an alkaline material with the metals at their highest oxidation states, and it is not harmful to the environment when disposal has been accomplished in this manner. The application must contain a narrative describing how the treatment facility will operate. The narrative should indicate how the accumulated sludge will be handled.

6.2.15 Suspended Solids

Many mine sites have only suspended solids to treat. In this case, the standard design is two settling ponds in series, each with a six-hour detention time. After the ponds are put into use, the pond volume may need to be adjusted to meet effluent standards. Usually a third pond, similar in volume to the first two ponds, will be sufficient to meet suspended solids limits. Occasionally, with clay particles, additional ponds or processes are needed.

6.3 Effluent Standards

The effluent standards for each permit are contained in National Pollutant Discharge Elimination System (NPDES) Limits of the issued permit. These limits vary from permit to permit depending on the background permit conditions. It is important to know the effluent limits before selecting the necessary reagents or designing the sizing of the treatment basins.

6.4 Treatment Basin Design

Typically, more than one treatment basin is utilized. Basins are used in a series, with the second basin acting as a polishing basin and allowing additional detention time. A third basin can be used to allow diversion of flow when the sludge volume has reached capacity and needs to be cleaned. A typical treatment basin design is shown in Figure 6.1, and a typical neutralizing unit is given in Figure 6.2.

Figure 6.1.
Typical Treatment Pond Design

TYPICAL TREATMENT POND DESIGN

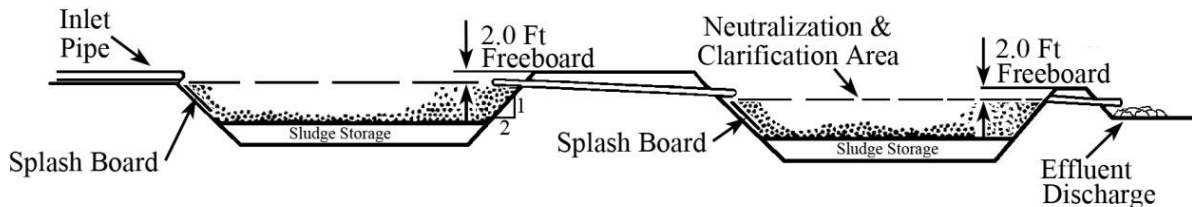
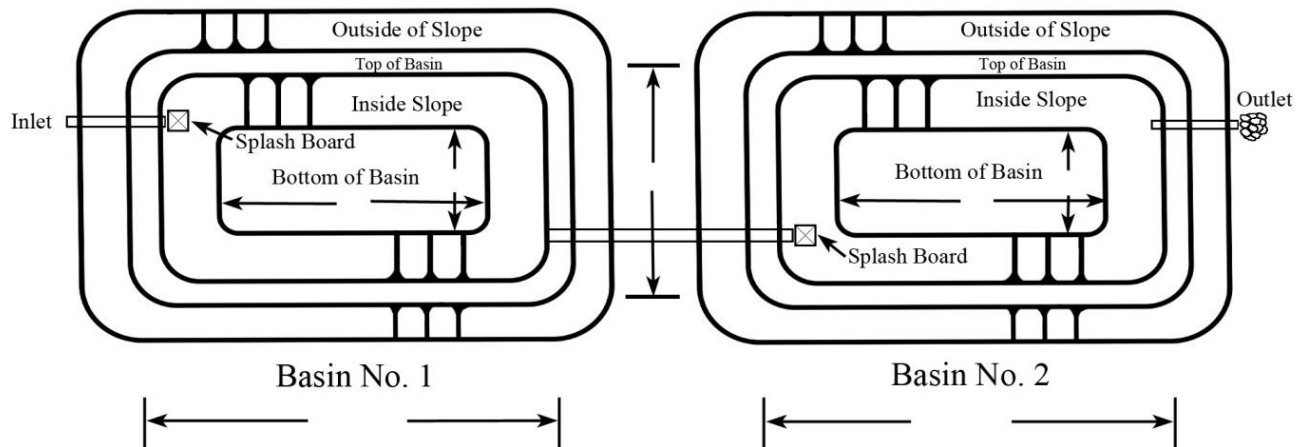

Cross Section

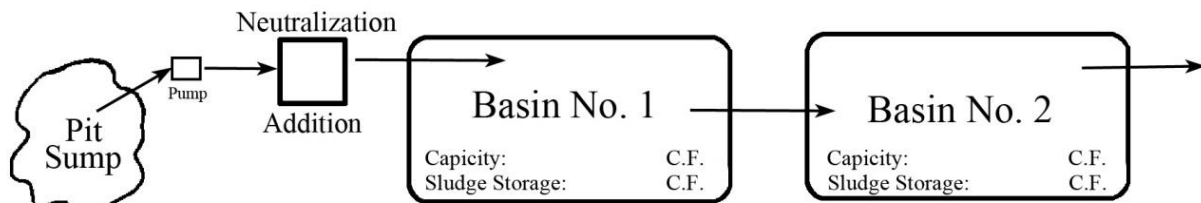

Schematic Diagram

Where necessary to meet permit effluent standards a third basin will be constructed.

Figure 6.2.
Typical Neutralizing Unit

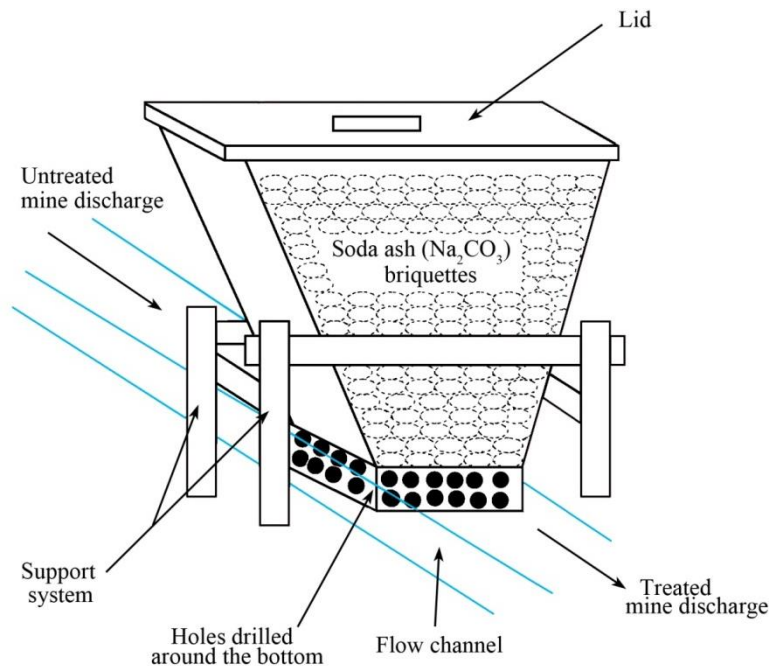

The design practice recommended by the Department calls for at least two treatment basins in series, each with a minimum detention time of six hours. The practice follows the theoretical basis established by Hustwit et al. (1992), who provide also primary references to Sung and Morgan (1980), Harvard University (1970), and Stumm and Lee (1961).

Increasing the pH with one of the alkaline reagents listed above causes the iron and aluminum to precipitate. Settleable solids should precipitate in 12 hours. Occasionally the detention time must be increased for solids, such as clay particles that are difficult to precipitate.

Treatment basins are sized according to the size of the open pit area, the quality, and quantity of runoff to be treated, the detention time that is needed to allow neutralization and settling to occur, and the pumping rate that will be used to dewater the pit. Sometimes, a small pit size and a high pumping rate will result in a short detention time, causing a discharge that exceeds the settleable solids limit. While conditions encountered in the field may vary from the expected conditions, a method of sizing the treatment basin is needed prior to opening the pit. The location of the treatment ponds should be chosen to augment the mining plan and must be built in their approved locations so that they discharge to the specific discharge points listed on the NPDES permit. The applicant must submit information that includes the total area draining to the pit, the computed runoff volume from a 10-year, 24-hour storm event, the expected water quality and treatment method, detention time normally required and the pump size and rate for the head to be encountered. The following section is an example of determining treatment basin volumes for primary and secondary treatment basins.

6.5 Example of a Treatment Basin Volume Calculation

$$V = 1.33 (A R C)$$

V = Volume of basin in ft³

A = Area draining to pit in ft²

R = Total 24 hour rainfall (feet) x detention time

C = Runoff coefficient, (C = 0.5 for Open Pit)

- 1.33 = Factor to allow for sludge storage
- Maximum pit length and width of mining operation 1,000 feet x 250 feet = 250,000 ft², including spoil piles that drain to pit and area below highwall diversion.
- 10-year, 24-hour rainfall is 4.0 inches = 0.333 feet
- 6-hour detention time = 0.25 days
- Volume calculations

$$V = 1.33 (A R C)$$

$$V = 1.33 (250,000 \text{ ft}^2) (4.0 \text{ inches}) (.25 \text{ days}) (0.5)$$

$$V = 1.33 (250,000 \text{ ft}^2) (0.333 \text{ feet}) (.25 \text{ days}) (0.5)$$

$$V = 1.33 (10,417 \text{ ft}^3)$$

$$V = 13,845 \text{ ft}^3$$

Basin size - Assuming a 6.00 feet water depth, the average surface area needed is about 2,300 ft². If a 25 feet bottom width is used, and a 50 feet length is used. For 2:1 side slopes the top width is 49 feet, top length is 74 feet, and the average area of the basin is about 2,300 ft². Using the prismoidal formula, the basin volume would be 14,052 ft³.

A secondary basin of the same size will also be constructed to allow an additional 6 hours of detention time in the second basin. If the area draining to the pit increases, additional detention time is needed for treatment. If effluent quality is not being met, a third basin should be constructed.

The treatment pond volume should be checked against the pumping rate to make sure that the detention time is greater than 12 hours. Computed treatment volume is 14,052 ft³ for each basin or 28,104 ft³ for both. Multiplying by 7.48 gal/ft³, this converts to 210,218 gallons. Checking the residence time with a typical 200 gal/min pump gives a residence time of 1,051 minutes or 17 hours, which is greater than the required 12 hours.

An increase in the pumping rate or a change to the mining method, such as using a larger dragline pit, may result in ponds that do not have enough residence time. Pumps can be throttled back, but only to about half the rated capacity. New calculations should be performed for a change in pit size, a change in pumping rate or substitution of a larger pump.

7.0 PASSIVE TREATMENT

7.1 Passive Treatment Systems

Passive treatment systems typically use hydraulic head to direct mine drainage through impoundments filled with alkaline reagent. Within the treatment impoundment, pH adjustment, precipitation reactions, and sludge accumulation occurs with minimal operational control.

Passive treatment systems can be classified based on the type of water they treat; net-alkaline treatment systems or net-acidic treatment systems.

7.1.1 *Net-Alkaline Passive Treatment Systems*

The primary treatment targets in net-alkaline water are ferrous iron and manganese. Passive treatment of iron-laden net-alkaline water typically involves constructing open-water or wetland impoundments to create an oxidizing environment, for the conversion of ferrous to ferric iron, and to promote settling of suspended particles (Figures 7.1 and 7.2). The primary functions of these systems are to dissolve atmospheric oxygen into the water, remove aqueous carbon dioxide, provide retention time for complete oxidization and settling of iron, and provide sludge storage capacity within the impoundment. These functions are completed without the use of electricity or chemical reagents. Oxygen and carbon dioxide are transferred by creating turbulent flow within the channeling or by manipulating the surface area to volume ratio of the impoundment. Settling is promoted by using baffles and slow flow velocities throughout the system. Important design factors include determining oxidation and settling times. When sized and constructed correctly, these systems provide many years of low-maintenance and effective treatment. The major maintenance is periodic sludge removal.

Figure 7.1.
Oxidation and Settling Pond: Note effective use of baffles for clarification

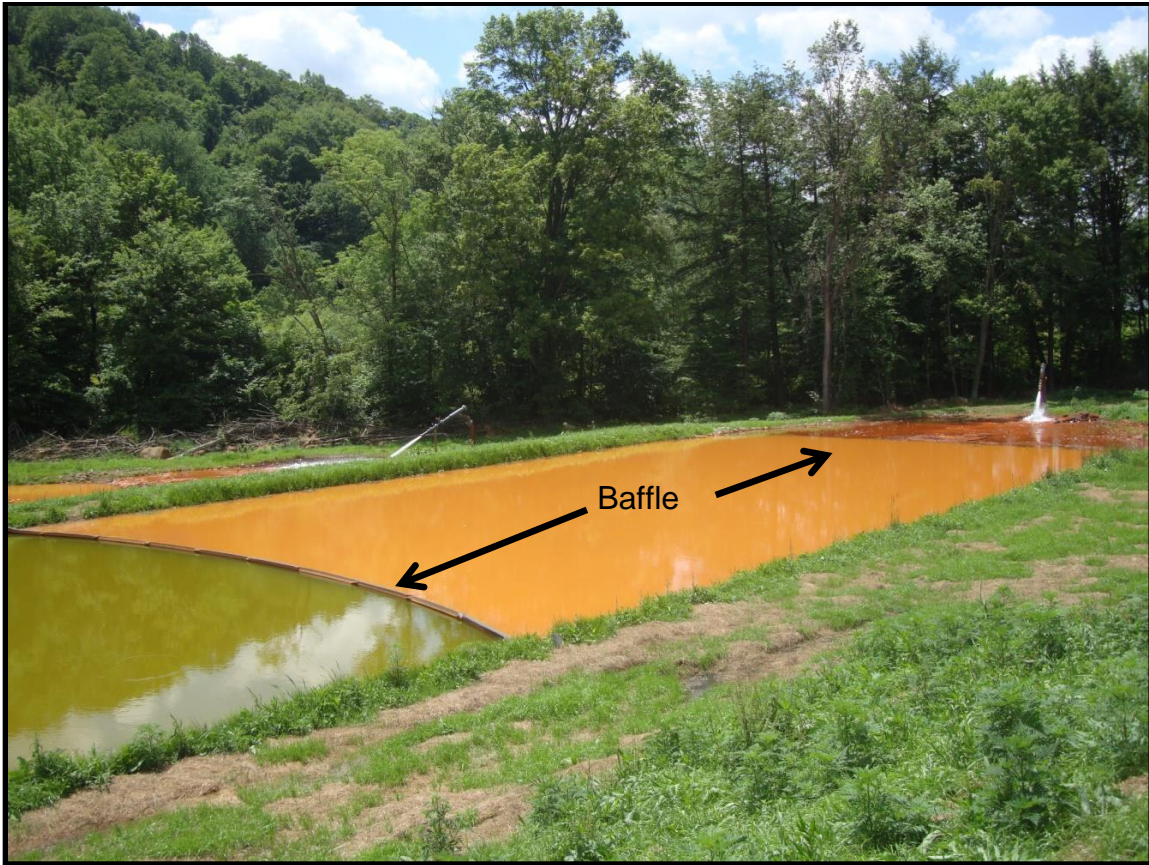

Figure 7.2.
Synthetically-lined wetland used in removing
low concentrations of suspended iron



Passive removal of manganese from net alkaline water involves directing water through a limestone-filled impoundment to promote biotically-induced oxidization and precipitation of manganese on limestone surfaces (Figure 7.3). The purpose of the limestone is not to dissolve and increase pH, but rather to provide a durable substrate with surface area for microbial growth. Manganese removal beds have proven to be both low-maintenance and effective given the appropriate water quality (low sediment, Fe and Al < 1.0 mg/L). Unlike the low-density sludge often associated with hydrous aluminum and iron precipitates, the manganese precipitates and forms on the surface of the limestone in crystalline forms, such as birnessite and todorokite. The major maintenance is periodic removal or cleaning of manganese-coated stone. Cleaning may entail using mechanical equipment to abrade the manganese minerals from the limestone surface.

Figure 7.3.
Typical Manganese Removal Bed



7.1.2 *Net-Acidic Passive Treatment Systems*

Unlike net-alkaline water, net-acidic water must be dosed with alkali reagent to achieve compliance with the pH 6.0-9.0 discharge requirement. Limestone is the most common alkali reagent used in passive treatment. Passive treatment of net-acidic water generally entails directing water through impoundments filled with limestone. The reaction between the acidic water and the limestone increases the pH and causes metals to become insoluble and precipitate. In many cases, the precipitation of metal hydroxide occurs within the void space of the limestone. Overtime, the precipitate accumulates, decreases the porosity, and hydraulically plugs the system eventually causing system failure. Predicting the timing and monitoring the progression of plugging is difficult. Systems treating higher metal-loading discharges are more prone to rapid plugging and unpredictable treatment than systems treating low metal-loading water. As a result, Section 7.3 of this manual presents a Risk Matrix that uses water quality and sizing criteria to evaluate the suitability of passive treatment.

There are three general classifications of net-acidic passive treatment systems: anoxic limestone drains, vertical flow ponds/limestone beds, and planned maintenance systems.

7.1.3 *Anoxic Limestone Drain (ALD)*

Anoxic Limestone Drains are generally designed to treat net-acidic mine drainage containing pH > 5.8 and ferrous iron. Using this pH restriction avoids placing ALDs on drainage containing ferric iron and aluminum, as these metals are relatively insoluble at pH > 5.8. ALDs contain a very small cross-sectional surface area perpendicular to flow and are easily clogged if metal precipitation occurs within the system. ALDs are designed to keep ferrous iron soluble while the pH and alkalinity increases within the system. Preventing ferrous iron oxidation within the system is accomplished by preserving an anaerobic

environment. Techniques to exclude oxygen include burrito wrapping the limestone in a synthetic liner, using “p-traps” on pipes, and collecting raw water subsurface (Figure 7.4). ALDs are often capped with a clay liner and covered with a soil layer that is crowned and vegetated.

As water flows through an ALD, carbonic acid dissolves limestone resulting in an increase in pH and alkalinity until net-alkaline conditions are achieved. Upon discharge, the water is oxygenated through turbulent-splashing to promote iron oxidization in a settling pond (Figure 7.5). The excess alkalinity neutralizes the iron acidity and results in net-alkaline water with a pH between 6.0 and 9.0. ALDs have proven to be the most reliable maintenance-free type of net acidic passive treatment system since minimal metal precipitation occurs within the limestone. A major design consideration is to evaluate the water to ensure sufficient carbonic acid to dissolve the limestone and generate net-alkaline water. Without sufficient carbonic acid, ferrous iron acidity may be greater than alkalinity and result in net-acidic conditions that require further treatment.

Section 7.3 provides the water quality criteria for evaluating whether a discharge is suitable for an ALD. Since minimal precipitate occurs within the limestone, ALDs are not subject to the Risk Matrix.

Figure 7.4.

Construction of an ALD: Limestone is placed within a synthetic liner



Figure 7.5.
Effluent pipes emanating from an ALD followed by an oxidization pond



7.1.4 Vertical Flow Ponds (VFP)/Limestone Beds (LB)

VFPs are impoundments containing a layer of limestone overlain by a layer of composted organic matter (Figure 7.6). Water flows downward through the compost layer (Figure 7.7) and limestone layer and exits the system through a piping network under the limestone (Figures 7.8 and 7.9). Limestone beds are impoundments filled with limestone (no compost layer).

Unlike ALDs, these two systems are applied to mine drainage containing ferric iron and aluminum and are considered to treat the broadest-range of mine drainage for two reasons. First, VFPs contain a large cross-sectional surface area perpendicular to flow. This large area provides sufficient volume to accumulate sludge within the void space of the limestone layer without hydraulic failure for extended periods of time. Secondly, the compost layer is designed to consume oxygen and chemically reduce ferric iron to ferrous iron. In theory, the ferrous iron will remain soluble as the pH and alkalinity are increased within the limestone since the water is void of dissolved oxygen. This combination of benefits allows these systems to treat waters containing ferric iron, ferrous iron, and aluminum for prolonged periods without major maintenance.

There are limits to using VFPs and LBs on metal-laden mine drainage. Many systems have been plagued with poor performance well before the declared design life. In most cases, maintenance involving excavation equipment is required to rehabilitate a poor-performing system. Most premature failures have resulted from hydraulic plugging from metal precipitate (Figures 7.10 and 7.11). Most designs incorporate elaborate flushing mechanisms (including solar-powered gate valves and automatic siphons) that are used routinely to drain the system(s) in an attempt to remove the metal precipitate. These systems are designed assuming the flushing system will remove the majority of the precipitates and minimize maintenance during the design life (Figure 7.12). Troubleshooting and maintenance of VFPs and LBs can be difficult and time consuming since the gradual plugging of these systems cannot be visually

monitored and located. Poor performing systems are investigated by dewatering the system and looking for problem areas before developing a rehabilitation plan. In any case, placing VFPs and LBs on high metal-loading discharges increases the maintenance, decreases design life, and leads to less benefits. Since VFPs and LBs are prone to plugging by precipitate, they are limited to “low” and “medium” metal-loading designations presented in the Risk Matrix in Section 7.3.

**Figure 7.6.
Two Vertical Flow Ponds**



**Figure 7.7.
The compost layer being placed on top of the limestone layer in a VFP**



Figure 7.8.
Underdrain piping system on top of a synthetic liner for a VFP



Figure 7.9.
Limestone being placed on top of the underdrain piping system



Figure 7.10.
Limestone bed clogged with iron hydroxide precipitate



Figure 7.11.
Limestone layer clogged with aluminum hydroxide precipitate underneath a relatively clean compost layer in a VFP



Figure 7.12.
Flushing a vertical flow pond
(Note the flushed sediment suspended in the settling pond)

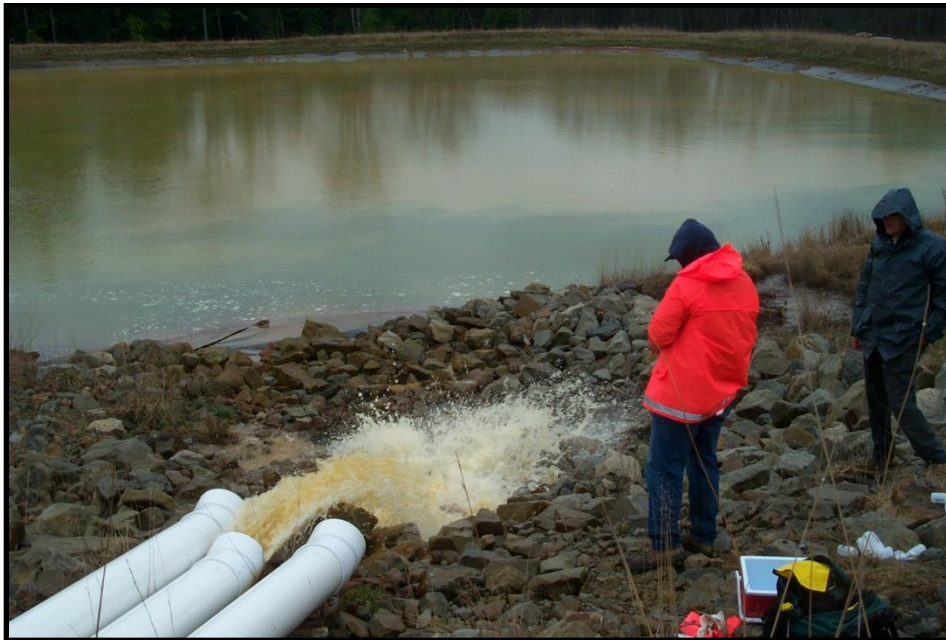

7.1.5 *Planned Maintenance Systems (PMS)*

PMS are impoundments or containers filled with limestone in which water travels vertically or horizontally through the system. The design and maintenance approach differs from traditional VFPs or LBs since PMS do not rely on compost to prevent precipitation or flushing mechanisms to remove precipitate from the system. During the PMS design process, recognizing and planning for precipitate plugging can make routine excavator maintenance easy and cost effective. Routine excavator maintenance includes agitating clogged sections of limestone to reestablish flow or routinely replacing or washing the limestone. Some PMS are designed to be flushed during excavation agitation, which can maximize precipitate removal.

7.1.6 *Ramped Limestone Beds (RLB)*

A ramped limestone bed (RLB) is an emerging type of PMS in which an impoundment is filled with limestone. The depth of the limestone increases from the influent side to the effluent side, resulting in an inclined limestone surface. The water elevation is held just below the surface of the limestone on the influent side to force contact between the mine drainage and the limestone. The mine drainage that enters the system is designed to flow horizontally to the effluent side with a long flow path that prevents short-circuiting. Over time, precipitate accumulates and the section of the limestone bed closest to the influent side becomes clogged. Since the surface of the limestone is inclined, the water simply flows past the clogged section until clean limestone is intercepted. Since the outlet elevation is below the surface of the limestone, plugging can be determined

based on where the water is “pooled” above the limestone (Figure 7.13). This feature allows operators to monitor the progression of plugging and easily locate areas in need of rehabilitation. A treatment operator can lower the outlet elevation (e.g. Agridrain) in an attempt to force water through the clogged area and reestablish the water level below the limestone. Eventually, an excavator is needed to agitate the clogged limestone or the limestone may need to be replaced to eliminate plugging and reestablish flow (Figure 7.14). RLBs do not require draining for maintenance as an excavator can operate on top of the dry limestone surface. If an RLB is constructed on what would be designated as “high” risk according to the Risk Matrix presented in Section 7.3, the frequency of maintenance becomes cumbersome and these systems lose their cost and operational advantage over active treatment systems.

Figure 7.13.
Water pooling indicates plugged sections of a RLB



Figure 7.14.
**Agitation using an excavator to break up precipitate and
reestablish flow in a clogged section of a RLB**



7.2 Best Management Practices for Passive Treatment Design

Since the inception of passive treatment technology and its subsequent increasing prevalence in mine drainage applications, advancements in the technology have occurred and continue to be developed. At the same time, a number of the original passive treatment technologies have been refined and are now considered typical or standard applications.

A passive treatment system includes many considerations and design features, which are universally common and prudent whether the technology involved is typical or innovative. Any approved passive treatment system must be designed in accordance with the BMPs and sizing criteria described herein.

The applicant must provide a narrative of the proposed passive treatment system design. The narrative should be done by the design engineer and should include justification of the sizing criteria used for all units in the system and all other selected design features the justification should cite literature, previous successful systems, and any other sources to justify design criteria selections.

The following BMPs are relevant to any passive treatment system design:

- a) Perform background flow measurements and sampling for chemical analysis on the water to be treated for a monitoring period encompassing one representative

hydrologic season that adequately captures both wet and dry weather conditions. At a minimum, conduct such monitoring for a period of twelve months with flows measurements and chemical analysis performed monthly. To the maximum extent practicable, monitor the correlation between the local precipitation and the flow data for the waters that will be treated. Evaluate whether precipitation for the background-monitoring period has been uncharacteristically wet or dry and consider this assessment in determining the design flow.

- b) Include the following parameters for chemical analysis of all background water samples collected at any water source being monitored for treatment:
1. Lab Analysis
 - i) pH, alkalinity, hot acidity, total iron, total aluminum, total manganese, sulfate, specific conductance, and total suspended solids. If the pH < 4, then speciate for iron to determine distribution of ferric and ferrous.
 2. Field Analysis
 - i) pH is required.
 - ii) Field alkalinity is highly recommended.
 - iii) Field-measured dissolved oxygen is required for ALD analysis.
 - iv) Any particular or additional chemical parameters suitable to aid in effective design and application of the selective passive technology selected.
- c) All analyses should be performed by a laboratory registered with or accredited by the Pennsylvania Laboratory Accreditation Program (PLAP).
- d) The design flow should be the 90th percentile flow based upon pre-design monitoring and the designer's knowledge and understanding of site conditions and restoration goals.
- e) When determining the design flow, consider the correlation of precipitation to flow volume and assess whether the pre-design monitoring period has been uncharacteristically wet or dry. Provide justification for the final design flow selected, including all supporting data and calculations.
- f) Conduct soils and other geotechnical analyses on proposed construction areas to establish the physical properties of the site with regards to the system design. Any system components intended to retain water, prevent leakage that would interfere with system performance or ability to monitor. Perform analyses and characterization of on-site soils to determine the adequacy of their use as liners versus the need for synthetic liner material. If soil liners are to be used, perform

volume estimates for verification of sufficient on-site soil quantities of the type required. Determine if the presence of bedrock will interfere with system construction. Determine if excavations as designed will intercept groundwater and if so, address the consequences and actions required. Such analyses should also include examination for the presence and extent of underground mining. The passive treatment system design must include a written summary and justification, prepared by the designer, explaining the soils and geotechnical design selections made as well as all supporting data and calculations.

- g) Design systems for a recommended life of 20 years. Systems may be considered with an alternate design life provided appropriate justification is given, including supporting data and calculations.
- h) During periods of high flow, allow for treatment of flow in excess of the design flow through the system, provide the excess flow is limited and not detrimental to the system integrity. To prevent the dislodging of accumulated precipitates and sludge from within the system as well as any other damage to the system due to high flow, be conservative with such excess flow through the system. Combine any untreated bypassed flow with treated effluent, preferably in a scenario where some settling or removal of precipitates may be accomplished prior to discharge within the receiving stream.
- i) At a minimum, the design should provide the capability for flow measurements and sampling of the untreated influent and treated effluent for each system. To the maximum extent practicable, provide the capability for water sampling internally within the system at locations where flow is transferred between system components. Where the opportunity is afforded and to the extent practicable, provide for additional flow measurement internally within the system.
- j) Provide access to all monitoring points intended for the purpose of flow measurements and water samples. At a minimum, monitoring points should include both the raw untreated influent and the treated effluent for each system. Access to the monitoring points does not need to be reached directly by a vehicle, but should be provided in a way that the tasks required can be performed accurately, efficiently and safely. The access should also be reasonable and unimpeded and not require special gear, equipment, clothing, footwear, undue effort, or risk. Provide sufficient space beneath the flow for insertion of an appropriately sized container at monitoring points where flow is to be determined by timed collection within a container. At monitoring points where depth of flow is to be measured or read from a scale or gauge, provide access directly to the point where such measurement or reading can be accurately accomplished.
- k) To the maximum extent attainable, provide for vehicle access to all areas or components of the system where operation, monitoring, and maintenance are to be involved. For areas where such activities would be expected to involve material transport, heavy equipment, and machinery, access should be designed accordingly. Provide for vehicular and equipment access that is safe, stable, solid and functional, with particular attention to access located along the tops of

FOR DISCUSSION PURPOSES ONLY (AGGREGATE ADVISORY BOARD)

embankments and across slopes. To the maximum extent practicable, provide for a safe, solid, and stable roadway with liberal width and turning radiuses. Avoid whenever possible, areas where vehicles or equipment are required to drive in reverse for long distances, along the tops of embankments, and/or across slopes. Provide site drainage that will prevent the vehicular and equipment access from eroding, becoming saturated or otherwise unstable and impassable due to water issues.

- l) Provide emergency overflow capability for each unit in the system including the use of appropriate lining material for erosion protection using design criteria from the Department's technical guidance "Chapter 102 Erosion and Sediment Pollution Control Program Manual" (363-2134-008).
- m) Provide each unit in the system with dewatering capabilities for the purposes of, but not limited to, maintenance and repair.
- n) Prevent peripheral surface water of any source unrelated to treatment from entering the treatment system.
- o) Prevent the loss of water from within the system and prevent the subsurface introduction of any external water into the system, which would compromise treatment.
- p) Provide a plan that indicates and discusses the sequence of events that would occur during an episode of major system maintenance. During maintenance events, consider the impact of non-treatment and how the stated design objectives and restoration goals would continue to be met. Whenever practicable, conduct such system maintenance during periods of low flow unless such action is considered critical. Include a description of the temporary treatment measures used while maintenance and/or rehabilitated is occurring on the system.
- q) Incorporate measures to prevent damage to the system due to wildlife and vandalism, to the maximum extent practicable.
- r) Within the Operations and Maintenance (O&M) Plan, provide a discussion of whether or not flushing will be used to maintain the system as well as the reasoning if flushing will not be used. If flushing will be used as part of the normal system O&M, provide an explanation of the flushing plan. The plan should explain, at a minimum, what volume is to be flushed, what the duration of flushing will be, how flushing is to be initiated and stopped, and how often flushing is to occur. If feasible, consider a separate pond to receive and retain the flush water and provide information on flush pond sizing, settling time and method of dewatering. If the pond will require attention prior to flushing, such as lowering the water level, highlight and explain such pre-flush activity in the O&M flushing plan. All flushing activities, including pre-flush, should be planned and carefully preformed so that existing settled sludge is not disturbed and that little or no suspended material is transferred out of the ponds utilized for flushing.

- s) For systems incorporating mixed media within a single treatment bed, particularly organic media, consider not flushing the system. Provide justification if such treatment beds are utilized and designated for flushing.
- t) If required by design or anticipated within the life of a system, provide a plan for sludge removal within the O&M Plan and incorporate required facilities, including access, when designing the system.
- u) Conduct an evaluation to determine whether additional permits, such as USACE or a Department's Chapter 105 permit, are required for system construction.
- v) Survey the site to obtain an accurate discharge elevation before designing the treatment system.

7.3 Design and Water Quality Criteria for Passive Treatment

- Oxidation/Settling Ponds

Sizing Criteria:

Minimum Retention Time = 24 hours at design flow

Water Quality Criteria:

Limited to net-alkaline mine drainage (either natural or after an alkaline-generating passive treatment cell).

Design Recommendations:

Distribute the influent across the width of the treatment unit using manifolds, level spreaders, open water forebays, or similar mechanisms. It is recommended that a wetland follows the oxidation/settling pond for polishing small concentrations of suspended solids since extremely small-suspended particles that cannot be settled using gravity can be adsorbed to organic matter in a wetland.

- Aerobic Wetlands

Sizing Criteria:

Aerial Iron Loading = 7-10 g/m²/day

Water Quality Criteria:

Limited to net-alkaline mine drainage.
Maximum Influent Iron Concentration = 15 mg/L

Design Recommendations:

Wetlands should be constructed for discharges containing low concentrations of iron or immediately follow oxidization and settling ponds to act as a polishing unit.

Distribute the influent across the width of the treatment unit using manifolds, level spreaders, open water forebays, or similar mechanisms. In order to promote and maintain vegetative growth, the maximum water depth is 18 inches.

- Anoxic Limestone Drains (ALD)

Recommended Sizing Criteria:

Limestone requirement = tons of limestone for 16 hour retention at design flow time + tons limestone required to neutralize acidity loading over design life

Water Quality Criteria:

pH > 5.8
Dissolved oxygen, ferric iron, and aluminum concentrations < 1.0 mg/L
Total suspended solids concentration < 5.0 mg/L

Design Recommendations:

ALD must maintain anoxic conditions (completely flooded)
Limestone: > 85 percent CaCO₃
Stone Size: AASHTO #1 or #3

- Vertical Flow Ponds (VFP), Limestone Beds (LB), & Ramped Limestone Beds (RLB)

Recommended Sizing Criteria:

Aerial Acidity Loading = 30 g/m²/day

Water Quality Criteria:

The risk matrix, presented at the end of this section, is used to determine the eligibility of a discharge for passive treatment. Passive treatment is permitted for a “Low” risk designation. For a “Medium” risk designation, passive treatment may be permitted upon further review by the Department, but not for a “High” risk designation.

FOR DISCUSSION PURPOSES ONLY (AGGREGATE ADVISORY BOARD)

Design Recommendations:

Distribute the influent across the width of the treatment unit using manifolds, level spreaders, open water forebays, or similar mechanisms. Amend the VFP compost layer with 15 to 25 percent fine limestone by volume.

Limestone: > 85 percent CaCO₃

Stone Size: AASHTO #1 or #3

- Manganese Removal Beds (MRB)

Recommended Sizing Criteria:

Minimum Retention Time = 24 to 36 hours at design flow

Water Quality Criteria:

Net alkaline mine drainage

Total suspended solids concentration < 5 mg/L

Design Recommendations:

Limestone: > 85 percent CaCO₃

Stone Size: AASHTO #1 or #3

Limestone Depth: ≤ 3 feet.

Risk Analysis Matrix				
Summation of Fe and Al Concentration	Design Flow Rate			
	≤ 25 gpm	> 25 ≤ 50 gpm	> 50 ≤ 100 gpm	> 100 ≤ 200 gpm
≤ 5 mg/L	Low	Low	Low	Low
> 5 ≤ 15 mg/L	Low	Medium	Medium	Medium
> 15 ≤ 25 mg/L	Low	Medium	Medium	Medium
> 25 ≤ 50 mg/L	Medium	Medium	High	High
> 50 mg/L	High	High	High	High
Summation of Fe and Al Concentration	Design Flow Rate			
	> 200 ≤ 400 gpm	> 400 ≤ 800 gpm	> 800 < 1600 gpm	≥ 1600 gpm
≤ 5 mg/L	Medium	Medium	Medium	High
> 5 ≤ 15 mg/L	Medium	High	High	High
> 15 ≤ 25 mg/L	High	High	High	High
> 25 ≤ 50 mg/L	High	High	High	High
> 50 mg/L	High	High	High	High
Low = Passive treatment is acceptable Medium = Passive treatment may be acceptable High = Chemical treatment required				

Note: gallons per minute – “gpm”

8.0 STREAMS AND WETLANDS

8.1 Mining Activities within 100 Feet of a Stream (25 Pa. Code §§ 77.504, 86.102)

Streams and wetlands are important resources in Pennsylvania protected by the Clean Streams Law, the Surface Mining Conservation and Reclamation Act, the Noncoal Surface Mining Conservation and Reclamation Act, and the Dam Safety and Encroachments Act among others. Streams and wetlands are protected from mining impacts, direct and/or indirect, by barrier areas, erosion and sedimentation control devices, and conservative effluent limits. During the permitting process, all potential stream and wetland impacts should be identified and evaluated. A pre-application is essential when possible impacts to streams or wetlands are proposed as part of a mining application.

A thorough site evaluation of all water related features is necessary before a mining plan and an E&SCP can be developed. All streams must be identified and categorized as one of three stream classifications: ephemeral, intermittent, or perennial. The stream classifications are defined in 25 Pa. Code Chapters 77, 86, 87, 88, and 93. Surface mining activities are prohibited within 100 feet of the bank of an intermittent or perennial stream unless a variance is obtained. A request for variance to the stream barrier must be included in the public notice.

Surface mining activities within 50 feet of the top of bank of a watercourse, within 100 feet of the bank of an intermittent or perennial stream, or within the 100-year floodway are prohibited unless the applicant obtains coverage under the Chapter 105 section of the mining permit application, or a separate Water Obstruction and Encroachment Permit, or the activity qualifies for a waiver as set forth in the Dam Safety and Encroachments Act and the Chapter 105 regulations. Surface mining activities include but are not limited to mineral extraction, haul roads, erosion and sediment control and stormwater management BMPs, treatment facilities, bridges, culverts, stream enclosures, and stream crossings. These activities are processed as part of the variance request and the Dam Safety and Encroachments Act will be checked on the issued permit's fact sheet.

The United States Army Corps of Engineers (USACE) can issue a general permit under Pennsylvania State Programmatic General Permit (PASPGP), an Individual Permit or a Nationwide Permit. Single and complete projects, including all attendant features, both temporary and permanent, which individually or cumulatively impacts 1.0 acres or less of waters of the United States, including jurisdictional wetlands, or 1,000 linear feet or less of permanent loss to stream channels can be authorized by the USACE in Pennsylvania under PASPGP-5 provided the project meets all other eligibility requirements. Surface mining activities impacting streams or wetlands within the jurisdiction of Section 404 of the CWA (33 U.S.C. § 1344) or section 10 of the Rivers and Harbors Act of 1899 (33 U.S.C. § 403) requires permit coordination with the USACE

However, larger individual or cumulative impacts or impacts to streams and/or wetlands may also require a separate federal Clean Water Act Section 404 permit along with a

state water quality certification as required by Section 401 of the Clean Water Act and an EA under 25 Pa. Code § 105.15.

8.1.1 Stream Barrier Areas (25 Pa. Code §§ 77.504, 86.102)

Barrier areas around streams are specified in the coal and noncoal regulations. The barrier area is 100 feet measured horizontally from the bank of a perennial or intermittent stream. Haul roads, the mining plan, and the erosion and sediment (E&S) control plan should be designed to avoid the barrier areas. Variances to the barrier area are usually not allowed in HQ and EV watersheds. If a clear environmental enhancement can be achieved, a variance may be approved.

If a stream crossing is necessary, it should be designed to be conducted with the least amount of impacts to the resources. If the drainage area of the stream at the culvert or bridge is over 100 acres, the Water Obstruction and Encroachment application for the culvert must include the Water Obstruction and Encroachment Permit application fee. Variances are typically not approved for mining within the barrier areas, especially if the mining will be below the stream elevation. The Department will evaluate the comments and make a determination as to the relevancy of the comments related to the potential impacts and other relevant factors.

According to a Memoranda of Understanding between the Department, the Pennsylvania Game Commission (PGC) and the PFBC, these resource agencies serve as consultants to the Department on wetlands and stream issues. These agencies review application materials and participate in on-site field reviews. Their comments are summarized in a memo to the permit chief for each application.

8.2 Stream Crossings (25 Pa. Code §§ 77.459, 77.523, 87.71, and Chapter 105)

As mentioned in Section 8.1, the pre-application process is vital when considering the permitting of a water obstruction or encroachment activity. Coordination with state and federal agencies during field meetings normally provides guidance for the preparation of the stream encroachment section, determining if the project qualifies under PASPGP, or when applicable, the individual Section 404 federal permit and state water quality certification process as required by Section 401 of the Clean Water Act. Federal requirements for the PASPGP can be coordinated with the District Mining Office by completing the Hydrology section of the surface mining application; or may be pursued independently by the applicant.

8.2.1 Culverts and Bridges/Water Obstruction and Encroachment Permit (25 Pa. Code § 86.102(12))

If the drainage area of the stream or floodway at the proposed location of a culvert or bridge crossing is over 100 acres or when wetlands are located in or along the floodway, an applicant's Chapter 105 Water Obstruction and Encroachment Permit the application for the culvert or bridge must include the Water

Obstruction and Encroachment Permit application fee and an Environmental Assessment as part of the mining permit.

Chapter 105 design criteria for culverts and bridges in rural areas require the structure to pass the peak discharge rate for the 25-year frequency flood. The structure must be designed and constructed with minimal backwater and without loss of stability; may not create or constitute a hazard to life or property or both; may not materially alter the natural regimen of the stream; may not increase the velocity or direct flow in a manner which results in erosion of stream beds and banks; may not significantly increase water surface elevations; and must be consistent with local flood plain management programs. Structures in suburban and urban settings are required to pass 50-year and 100-year frequency flood flow, respectively. In determining flood flows and frequencies, hydrologic analysis shall be by methods generally accepted in the engineering profession.

Proposed bridges or culverts should blend into the topography and streambed that exists at the crossing location. The structure should be sized so that flows can enter and exit the structure without a major constriction. This is even more important on larger drainage areas where there is a continuous flow through the structure. Culverts that constrict the existing stream cross - section will cause accelerated channel erosion and flooding in the vicinity of the structure. The Department may allow culverts and bridges in rural areas that do not pass the 25-year frequency to be utilized when:

- The proposed culvert or structure fits the existing stream channel and has an equivalent cross-sectional area.
- A means of passing the 25-year frequency flow is provided. (The additional flow could be handled in a rock-lined overflow channel.)
- The size of the structure proposed and the amount of fill over the structure will not present a hazard if the structure were blocked or over-topped.

The District Mining Office should be contacted to discuss these situations as they occur.

Typically, corrugated steel pipe or arch pipes are used. Table 8.1 is a listing of common sizes. (Note: Actual dimensions may vary depending on the selected pipe material and the manufacturer's specifications.)

Table 8.1: Common Pipe Sizes

Circular Pipe		Pipe Arch			
Diameter		Span		Rise	
(in)	(mm)	(in)	(mm)	(in)	(mm)
12	305	(n/a)	(n/a)	(n/a)	(n/a)
15	381	17	432	13	330
18	457	21	533	15	381
21	533	24	610	18	457
24	610	28	711	20	508
30	752	35	889	24	610
36	914	42	1067	29	737
42	1067	49	1245	33	838
48	1219	57	1448	38	965
54	1372	64	1626	43	1092
60	1524	71	1803	47	1194
66	1676	77	1956	52	1321

8.2.3 Culvert/Bridges/Permit Application Requirements (25 Pa. Code § 105.152)

Where a culvert or bridge is proposed the following information must be provided:

- Plans and details showing the location, type, size, and height of the structure and detailing the topographic features, elevations and structures so as to enable an appraisal of the hazard potential of the structure.
- A hydraulic and hydrologic analysis of the structure, which shall include data on size, shape and characteristics of the watershed; the amount and frequency of the design flood; the hydraulic capacity of the structure; the hydraulic capacity of the channel upstream and downstream; and where flooding is a problem, flood damage and backwater analysis.
- A description of the character of the stream bed and banks and a profile of the streambed for a reasonable distance above and below the proposed location showing slopes of bed, normal water surface and flood water surface.

Other information as the Department may require:

- Cross-sections upstream, downstream and at the proposed location of the structure showing normal and flood water surface elevations and topographic features, elevations, etc., necessary for an appraisal of the hazard potential of the structure.
- A narrative description of the construction methods and sequence including water handling during construction, and erosion and

sedimentation controls, and plan for the control of channel erosion above and below the structure (i.e., riprap).

- Indicate if the structure will be temporary or permanent (include plans for removal of temporary structures). The Department may allow a stream crossing to remain provided that a notarized landowner letter is submitted allowing for it, includes language accepting responsibility for the structure, and any supporting information that the Department may require. In addition, the crossing must be able to safely convey the peak discharge rate for the 100-year flood with minimal backwater and without loss of stability for the post mining drainage area.

8.3 Existing Stream Crossings (25 Pa. Code §§ 87.63, 88.43)

Existing stream crossings may be considered for access to a mine site. Dependent on the setting, the structure and its overflow conveyance must be able to safely pass the peak discharge rate for rural, suburban, or urban flood flow frequencies with minimal backwater and without loss of stability. Information on the existing structures in the mining permit application must be provided when the applicant proposes to utilize an existing structure. If the existing crossing were part of a road that met the definition of public road in Chapter 86 or common use road in Chapter 88 the crossing would be outside of the permit area and not need to be addressed in the permit application. The following information is required when proposing to utilize an existing structure.

- The public notice should state that an existing stream crossing of a particular stream is to be utilized as part of the mining permit operation.
- The Operational Information Section of the Bituminous Surface Mining Permit Application should be completed for the existing structure. This information should include the size, type and the current condition of the structure. Other information that is necessary for a new structure would be the stream profile, cross-sections, watershed hydrology, and hydraulic analyses.

If an existing structure was proposed for replacement or was to be modified, the permit processing would closely follow that for a new structure. An example of a major modification would be increasing the length or width of a structure.

The permit application should indicate any needed work such as placement of guide rails, widening of the roadway surface, or the addition of a roadway surface.

If the drainage area is greater than 100 acres (40.47 ha) and the structure is extensively modified or replaced, then a permit application fee for an obstruction would be required. In addition, a PASPGP must be approved by the USACE.

8.4 Temporary Road Crossings (32 P.S. § 693.7 and 25 Pa. Code § 105.441)

The Department can authorize activities under PASPGP or as an individual permit. The District Mining Office has the authority to authorize general permits under Chapter 105.

General Permit-101 (5600-FM-MR0054) and General Permit-102 (5600-FM-MR0059) can be used for temporary road crossings and access road crossings, respectively. The BMR-GP-101 and BMR-GP-102 are not applicable for stream crossing locations proposed as main mining haulage routes that will be subject to continuous use by heavy equipment and haul vehicles.

The general permit procedure does not change or impact the way in which normal obstructions and encroachments are handled and processed. The use of the general permit as approved by the District Mining Office is limited to activities that take place within the permit area and is limited to a period of time not to exceed one year unless extended in writing by the Department. The general permit procedure would be useful for the movement of surface mining equipment or for the construction of boreholes or vents.

If the proposed location for the use of the water obstruction or encroachment is outside of the mining permit area, the permittee should contact the appropriate Regional DEP Office to schedule a pre-application meeting.

8.5 Stream Reconstruction and Channel Changes (25 Pa. Code §§ 87.104, 88.94, 88.189, 88.294, 105.221, 105.231)

Stream reconstruction or modification of a stream channel must be consistent with the requirements set forth in 25 Pa. Code 105.231(a).

Intermittent and perennial streams must be protected by barrier areas erosion and sedimentation controls and other protective measures. The Department may allow relocation or a change to the channel of an intermittent or perennial stream when it can be demonstrated that an environmental enhancement can be achieved. An example of this would be relocation and re-establishment of surface drainage for a stream that is currently lost to deep mine workings. Another example would be reconstruction of a stream that was mined through and abandoned before the current regulations became law. The reconstructed stream channel should duplicate the original historical stream in capacity and character. A similar nearby stream reach can be imitated with similar pools and riffles, meanders, streambed, and riparian vegetation. Trees and shrubs are required to be planted when the existing channel has such cover, to reduce thermal effects and provide shade.

An applicant proposing to affect a stream channel should provide the information required by the Wetlands section. Chapter 105 regulations require a permit application fee for intermittent and perennial stream relocations. The design of stream relocations of perennial and intermittent streams must be certified by a qualified registered professional engineer.

8.5.1 Pennsylvania Fish and Boat Commission Guidelines for Stream Relocations

The PFBC guidelines are acceptable to the extent that they do not contradict applicable Department regulations. The PFBC has the following guidelines for

perennial stream relocations for mining projects demonstrating environmental enhancement.

- Provide the same hydraulic capacity as the present stream.
- Approximate the original stream length by including meanders in the channel design. Meanders should not be included when the gradient exceeds five (5) percent.
- Limit the new average channel width to no more than 1.3 times the original channel width. Use of a low-flow channel may be necessary depending upon channel design to keep a main channel as narrow as possible. A low-flow channel provides greater water depth during periods of low flow. The greater water depth enhances fish and benthic organism survival during these critical periods.
- Vary the channel gradient in order to establish pools and riffles. Alternate pools and riffles at distances of every five (5) to seven (7) stream widths. Pools should be placed at the downstream end of all meanders if possible.
- Stream banks should have slopes of 2:1 to 3:1 (horizontal to vertical).
- Stream banks should be protected from erosion with turning vanes, downed trees, root wads, or riprap on the outside of curves and the inside of bends. Vegetative plantings restoring riparian vegetation should consist of such plant species as purple-osier (basket) willow, tag alder, red-osier dogwood, rhododendron, or ninebark.
- The stream channel should include a clay liner covered with filter cloth. Substrate material composed of the following particle sizes should be then placed upon the silt preferably in the low flow channel:
 - ❖ 25 percent coarse rubble (6 in to 12 in diameter).
 - ❖ 25 percent fine rubble (3 in to 6 in diameter).
 - ❖ 25 percent coarse gravel (1 in to 3 in diameter).
 - ❖ 25 percent fine gravel (0.12 in to 1 in diameter).
- In consultation with the PFBC, fish habitat improvement structures should be incorporated into the final channel design plan if water quality and quantity indicate the potential for fish survival.
- Elevated flood plains and vegetative plantings should be used when possible to control water velocities. This will keep the channel appearance as natural as possible and costs for riprap lower. The uses of riprap,

vegetation/planting or other velocity control measures are required from the edge of the flow channel to the 25-year flood plain (see Figure 8.1).

Figure 8.1.
Stream Relocation Cross-Sections

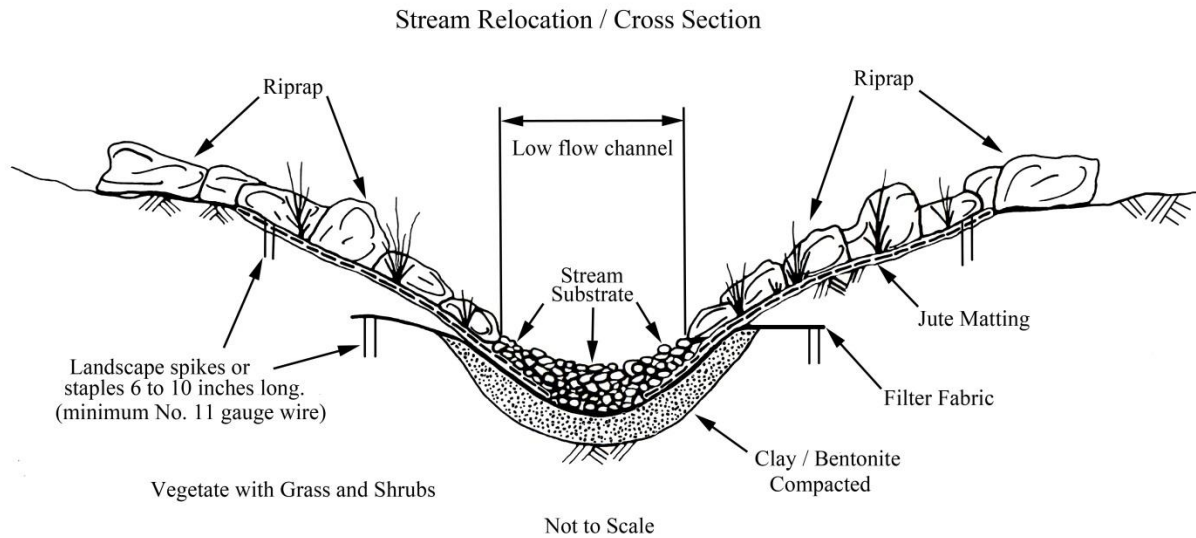

8.5.2 Importance of Pre-Application Process with Streams

Chapter 105 requires an evaluation of all streams within the proposed mining permit area. The Streams/Wetlands sections, of the Bituminous and Industrial Minerals Surface Mine Applications relate to streams on mine sites. Streams should be delineated by a qualified professional to identify the various functions and values associated with that stream. If streams exist that must be protected as required by Chapter 93, 105 or other applicable regulations, then that will affect the operations plan and the E&S control plan for the project site.

8.5.3 Stream Impacts: Avoid, Minimize, Mitigate

It is best to avoid impacts to streams. If that cannot be done, then the impacts should be minimized. Applicants must submit an alternatives analysis to environmentally justify their proposed mining/support activities. If possible, the applicant should arrive at the least environmentally damaging practical alternative that is acceptable to state and federal agencies. Depending on the functions and values of the stream impacted, upfront, current, or post-mining mitigation will normally be required. In all cases where any streams are affected and mitigation cannot be achieved as defined by 25 Pa. Code § 105.1, streams and the functions and values associated with such streams, shall be compensated for in accordance with Chapter 105 regulations. The Department further recommends that the compensatory mitigation be undertaken in accordance with any of the Department's supplemental technical guidance. Long term monitoring and maintenance is needed when compensatory mitigation has been performed.

8.6 Mining and Wetlands (25 Pa. Code Chapter 105)

Wetlands in Pennsylvania are considered an important aquatic resource. They provide many significant functions and values including storage of natural stormwater, habitat for aquatic and terrestrial species, and recharge for groundwater and surface water systems. In the surface mine permitting process, wetlands are treated similarly to streams, with both being addressed in streams and wetland sections of the application. The hydrology, vegetation, and soils of wetlands are protected from the effects of most encroachments in accordance with the Department's laws and regulations.

In Pennsylvania, wetlands are protected under both state and federal laws. Mining near wetlands is regulated at the state level under Chapter 105 and other applicable regulations. At the Federal level, wetlands are regulated under Section 404 of the Federal Clean Water Act (33 CFR Part 320-330). For non-mining programs, there is a Joint Permit Application. However, for coal and industrial minerals (noncoal) mining, the federal and state permitting processes are separate and distinct. Regionally, the state is normally the lead agency for water obstructions or encroachments in wetlands. It is important to coordinate all field/office wetland encroachment permitting meetings jointly with both the state and federal agencies at the pre-application stage and throughout the permitting procedure. All mining related activities are reporting activities under current PASPGP, and are reviewed and approved by the USACE. Obtaining approval under one agency's permitting process does not guarantee approval under the Department's permitting process. On all wetland issues, both the PFBC and the PGC have input into the permitting process. The following sections will discuss the laws of Pennsylvania as they pertain to mining and not the Federal laws.

Before an applicant submits a permit application, wetlands must be identified and delineated in the field. Wetlands should be delineated in the field by qualified wetland personnel and must be categorized as either Exceptional Value (EV) or other wetlands under Chapter 105. Personnel should refer to the 1987 Corps of Engineers "Wetland Delineation Manual (Technical Report Y-87-1)", the applicable Regional Supplements and the guidance provided by the United States Army Corps of Engineers, Major General Arthur E. Williams' memorandum dated 6 March 1992, Clarification and Interpretation of the 1987 Manual and any subsequent changes as the methodology for identifying and delineating wetlands in the Commonwealth. Wetlands on the permit area and those adjacent to that may be impacted, must be delineated. However, all wetlands within 1,000 feet must be shown on the exhibits.

Wetland impacts should be avoided. If avoidance is not feasible, impacts are to be minimized to the maximum extent practicable. If the wetland is determined to be exceptional value under 25 Pa. Code § 105.17, the applicant must affirmatively demonstrate in writing that they meet the requirements in 25 Pa. Code § 105.18a. In all cases where any wetlands are affected and mitigation cannot be achieved as defined by 25 Pa. Code § 105.1, wetlands shall be compensated for in accordance with Chapter 105 regulations. The Department further recommends that an applicant undertake the compensatory mitigation in accordance with any of the Department's supplemental technical guidance. Surface mining activities impacting streams or wetlands within the jurisdiction of Section 404 of the CWA (33 U.S.C. § 1344) or section 10 of the Rivers

and Harbors Act of 1899 (33 U.S.C. § 403) requires permit coordination with the United States Army Corps of Engineers (USACE).

8.6.1 Importance of Pre-Application Process with Wetlands

Chapter 105 requires an evaluation of all wetlands within the proposed mining permit area. The regulations distinguish between “exceptional value” wetlands and “other” wetlands and stream section of the Bituminous and Industrial Minerals Surface Mine Applications relate to wetlands on mine sites. Wetlands within the permit boundary should be delineated using the 1987 Corps of Engineers Wetlands Delineation Manual (Technical Report Y-87-1) along with the Interim Regional Supplement to the Corps of Engineers Wetland Delineation Manual: Eastern Mountains and Piedmont Region as references in completing the streams and wetlands sections of the application.

Identification and delineation of the wetlands on and along the proposed permit area should be completed before or during the pre-application stage. If wetlands exist that must be protected as required by Chapter 105, then that will affect the operations plan and the E&S control plan for the project site. The applicant should use qualified personnel for the identification and delineation of wetlands. The wetlands personnel should field delineate all of the wetlands within the proposed permit area. The applicant, the wetlands personnel, and the state and federal agencies should meet to discuss the functions and values of the delineated wetlands. If the wetlands are classified as “Exceptional Value” under Chapter 105, in general it will be difficult to obtain permission to affect them. An example of exceptional value wetlands would be wetlands associated with streams having a wild trout population. In general, wetlands having high functions and values, such as wooded wetlands, or scrub-shrub wetlands will be protected, while other wetlands resulting from old mining pits or old sedimentation basins will be reviewed by the District Mining Office for approval.

8.6.2 Avoid, Minimize, Mitigate

It is simply best to avoid impacting wetlands. If that cannot be done, then the impacts should be minimized. Applicants must submit an environmental alternatives analysis to justify their proposed mining/support activities within wetland areas. If possible, the applicant should arrive at the least environmentally damaging practical alternative that is acceptable to state and federal agencies. Depending on the functions and values of the wetland impacted, upfront, current, or post-mining mitigation will normally be required. In all cases where any wetlands are affected and mitigation cannot be achieved as defined by 25 Pa. Code § 105.1, wetlands shall be compensated for in accordance with Chapter 105 regulations. The Department further recommends that the compensatory mitigation be undertaken in accordance with any of the Department’s supplemental technical guidance. Usually, the replacement wetland at a minimum will have an area ratio of more than one-to-one to the affected wetland with the same functions and values. Long term monitoring and maintenance is needed and

wetland replacement bonds are specified and held by the Department until the replacement wetland has been determined to be functioning.

8.6.3 *Protected Wetlands*

If a wetland must be protected and it is near the mining activity, it is necessary to protect both the wetland and its hydrology, or water source, to ensure that mining does not drain or interfere with the wetland as an indirect impact.

A hydrogeologist will need to determine the water source and the aquitard that holds the water in the wetlands. The water source and the aquitard must be protected to keep the existing functionality of the wetland. Since there are many types of wetlands, riverine, palustrine, emergent, etc., each wetland must be evaluated by qualified wetlands personnel to determine the soil structure, plants, and hydrology.

8.6.4 *Streams and Wetlands (Application Section)*

The application requests information relating to wetlands that may be affected by the proposed mining activities. Information should be provided for each area/type of wetland. If there are several water-filled mine pits, the information may be provided for the pits as a unit. If two or more wetlands are along a stream, then the information required in Streams and Wetlands Section of the application may be provided for that group of wetlands along the stream. The information must be provided by qualified wetlands personnel who must list their credentials in wetland section of the surface mining application. It is also suggested that the applicant include a delineation map at an enlarged scale to show the discernible boundaries of the wetlands, including key data/photo point locations.

8.6.5 *Replacement Wetlands*

Depending upon the functions and values of the wetlands that will be or have been impacted by mining, the replacement wetland may be achieved by simply modifying a sedimentation pond or reestablishing a forested wetland or a scrub-shrub wetland. The area of the replacement wetlands' will at a minimum, be a 1:1 replacement ratio, or greater as the Department may require based on the acreage affected and the functions and values adversely affected by the project. Qualified wetlands personnel must be used to design the replacement wetlands to assure that the functions and values closely mimic those of the wetlands that were affected by mining. The Wetland Mitigation/Replacement Plan should follow the guidelines set forth in the Department's guidance document "Design Criteria - Wetlands Replacement/Monitoring" (363-0300-001).

9.0 MINING NEAR PUBLIC ROADS (25 PA. CODE §§ 77.504, 86.102, 87.78, 88.57)

Mining is prohibited within 100 feet of the outside right-of-way line of any public road, except where the Department, with concurrence of the agency with jurisdiction over the road, allows the public road to be relocated or the area affected to be within 100 feet of the right-of-way.

9.1 Permitting Requirements

When an application for a mining permit is submitted to the Department, a map showing the permit area is forwarded to the local municipality and the PennDOT Engineering District Office. Public notice is required where mining activities are proposed within 100 feet of the right-of-way of a public road. The public notice should indicate if the mining activities include the temporary relocation of a public road.

9.2 PennDOT Roads

A Plan of Intent is required by PennDOT whenever surface mining activities will be within 100 feet of the right-of-way. This plan includes an Exhibit 9 and cross-sections of the proposed mining. The Plan of Intent must be approved by the PennDOT District Engineer or District Geotechnical Engineer.

Mine operators should contact PennDOT prior to submitting an application for a permit to conduct surface mining activities within 100 feet of the right-of-way of the road. State route, segment, and offset information can be obtained from the PennDOT Engineering District or the appropriate County Maintenance Department. The nearest intersection should be provided as a reference point.

Whenever surface mining activities are within 100 feet of a state highway, PennDOT policy is to require an earthen barrier with safety barricade and warning signs. Figure 9.1 shows an example of such a barrier. In some cases, a natural earthen barrier with a constructed safety barricade and warning signs will be adequate for traffic and safety protection. Figure 9.2 shows an example of such a barrier. The PennDOT District Engineering Office or the agency with jurisdiction over the road should be contacted for site-specific requirements.

Figure 9.1.
PennDOT Requirements, Typical Cross-Section for Proposed Activities
within 100 feet of the Right-of-Way along State Routes

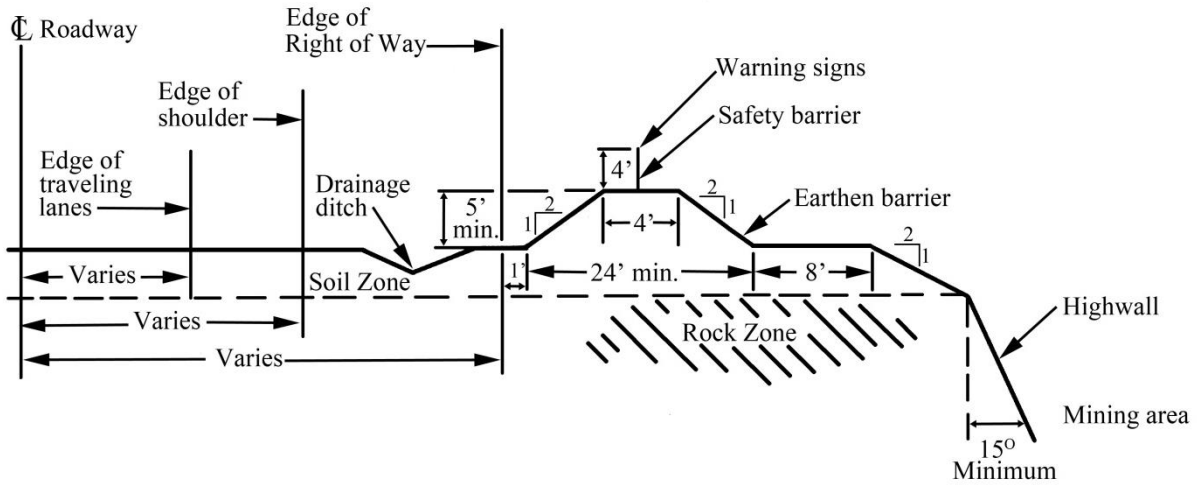
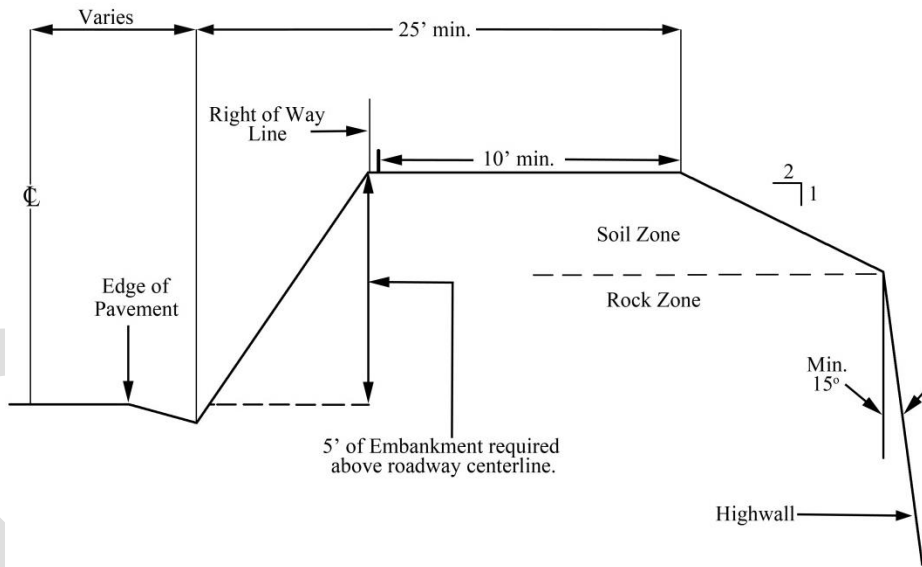

Figure 9.2.
Traffic Control Using Natural Earthen Barrier



9.3 Township Roads

Mining within a 100 foot Township road barrier requires a signed, dated, and notarized Township Road Agreement from the township supervisors. Many rural townships do not have a township engineer, so the Department must be sure that all barriers and distances are clearly specified. A “PennDOT type” earthen barrier with orange safety fence on top is required within the variance area between the road and the open pit. The consultant should submit several dimensioned cross - sections within the variance area showing the highwall, the earthen barrier, the right of way line, and the township road. The earthen

berm and safety fence must be in place before any surface mining activities take place within the variance area.

9.4 Common Use Roads (25 Pa. Code §§ 77.1, 77.633, 88.1, 88.150, 88.243, 88.347)

Common use roads, as defined in Chapters 77 and 88, are existing roadways that normally are utilized by two or more operators, agencies, or persons for access, safety, fire protection and other common purposes.

Operators using common use roads to service permitted areas shall be responsible for maintaining the roads in a stable and safe condition throughout the life of the permit. Common use roads are not permitted under bituminous surface mining regulations, and must be within the permit boundary and must be bonded to the public road access point. Common use roads regulated under Chapter 77 are not required to be bonded nor entirely within the permit boundary. Common use roads regulated under Chapter 88 may require bonding and must be included within the permit boundary.

Common use roads are subject to Department regulations and the permitting requirements as defined in the Department guidance document “Roads Associated with Coal Mining Activities” (563-2000-609).

DRAFT

10.0 SLOPE STABILITY

The stability of certain structures proposed in connection with mining activities, as well as steep slope mining and reclamation activities, is a major concern regarding environmental pollution prevention and public health and safety. Rules and regulations have been promulgated to ensure certain structures associated with mining activities and certain mining and reclamation proposals are designed and constructed properly. Therefore, a “stability analysis” must be provided to the Department for evaluation and approval of these activities.

10.1 Regulations

The regulatory requirements pertaining to stability analysis are Sections 77.571, 77.573, 77.594, 87.1, 87.73, 87.79, 87.81, 87.131, 87.174, 87.175, and 88.313. Definitions for various terms are given in Section 87.1.

10.2 Stability Analysis

A stability analysis must be conducted for all proposals to:

- Dispose of excess spoil from mining operations if the excess spoil will increase the reclamation slopes (§ 87.131).
- Conduct coal surface mining and reclamation operations on steep slopes (§ 87.174). A steep slope is a slope of more than 20 degrees (36 percent) or such lesser slope as may be designated by the Department after consideration of soil, climate, and other characteristics of the region.
- Request a variance from regrading to approximate original contour (§ 87.175).
- Construct impoundments or dams with a volume greater than 20 acre-feet (2.47 ha m) (§ 87.73).
- Other structures as required by the Department to protect public health and safety. These criteria may be based on such items as the size of the facility and its proximity to public roadways, streams, and populated areas.
- Develop a working bench in consolidated rock greater than 50 feet height.
- Develop the upper most face in consolidated rock to greater than 65 feet height on a noncoal operation (§ 77.571). Remove lower benches on a final working face on a noncoal operation.
- Reclaim to a slope greater than 35 degrees on a noncoal operation.

FOR DISCUSSION PURPOSES ONLY (AGGREGATE ADVISORY BOARD)

The slope stability analysis provided for the above-mentioned activities should include the following:

- Minimum required computed static and seismic factors of safety.
 - ❖ For excess spoil disposal fills, a minimum long-term static factor of safety of 1.5 and a seismic factor of safety of 1.1 is required (§ 87.131).
 - ❖ For steep-slope operations, a minimum static factor of safety for all portions of the reclaimed land of 1.3 is required. There is no minimum requirement for a seismic factor of safety on these operations (§ 87.174).
 - ❖ The lowest factors of safety for the most critical zones within and beneath the proposed structures must be listed.
- Methodology utilized in determining factors of safety and assumptions that are the basis for calculations.
 - ❖ Utilize an acceptable computer model.
 - ❖ Provide adequate field and laboratory testing such that actual conditions and properties of materials are ascertained and utilized in the computer modeling.
 - ❖ Cohesion values and internal angle of friction for each soil type and waste material associated with modeling must be verified by laboratory tri-axial testing of materials in a consolidated, undrained state at the required field density.
- Additional stability requirements and considerations:
 - ❖ If there are any geologic discontinuities (e.g. faults, joints, dikes, paleo-channels), explain what measures were used to analyze and account for them in the slope stability analysis and resulting factor of safety.
 - ❖ If there are any clay horizons or known unstable units in the strata beneath the proposed structure, explain what measures will be taken to remove or stabilize these units.
 - ❖ If there are any saturated zones or layers subject to artesian pressures beneath the proposed structure, explain what measures will be taken to remove or drain these areas.
 - ❖ The effect of subsidence from deep or auger mining on the stability of the proposed structure. Describe what measures will be taken to minimize subsidence beneath the proposed area to ensure stability of the area.
 - ❖ The effect of blasting within the proposed area or adjacent areas on the stability of the proposed structure (seismic stability analysis).

- ❖ The presence of organic or other soft material that would jeopardize the stability of the embankment.
- ❖ If the minimum factor of safety requirements cannot be met, keyway cuts or excavation into stable bedrock or bedrock toe buttresses may be proposed and included in modeling to stabilize a fill.
- The following are requirements to follow when surface mining occurs in steep-slope areas:
 - ❖ No material except material used to construct road embankments shall be placed downslope below the bench or mining cut.
 - ❖ The disturbed area shall be returned to approximate the original contour with compacted spoil, except for approved terrace backfill on pre-act pits.
 - ❖ Material in excess of that required for backfilling and grading shall be disposed of as excess spoil.
 - ❖ Woody materials shall not be buried in the backfill unless the applicant demonstrates that the proposed method for disposal will not deteriorate the stability of the backfilled area.
 - ❖ Unlined or unprotected drainage channels shall not be constructed on the backfilled areas.

11.0 AIR POLLUTION CONTROL PLAN

11.1 Processing Facilities

Any proposed processing facilities must be identified and described in the Air Quality section of the coal surface mine permit or large noncoal mine permit application. The proposed location of these facilities must be shown on the Exhibit 9 Operations Map.

For Coal Processing Facilities, if any of the following apply then an Air Quality Permit will be necessary:

- Coal handling facilities processing 200 tons/day
- Facilities that include thermal dryers
- Facilities that include pneumatic coal cleaning devices
- Facilities with diesel fired Internal Combustion (IC) engines > 100 hp, or
- Facilities with stationary diesel fired IC engines regardless of size, with combined NOx emissions greater than 100 lbs/hr, 1,000 lbs/day, 2.75 tons per ozone season and 6.6 tons/year on a 12-month rolling basis

For most operations, a General Plan Approval and/or General Operating Permit BAQ-GPA/GP-12 will need to be obtained. An application for authorization to use General Permit BAQ-GPA/GP-12 (2700-PM-AQ0212) must be completed and submitted to the appropriate District Mining Office.

For Industrial Mineral Processing Facilities, the DEP Regional Air Quality Office must be contacted to obtain a separate Air Quality Permit, unless that Program grants an exemption. In the Air Quality section of the application, you must provide the date that you contacted the Regional Air Quality Office and copies of any exemptions or authorizations granted by that office.

11.2 Fugitive Dust Control

The Air Quality section of the coal surface mine permit application or the large noncoal mine permit application, requires a fugitive dust control plan for the proposed mining operation. If an Air Quality permit is required for processing activities on the site, all activities not covered by that permit must be addressed in this section. The release of fugitive emissions is generally prohibited. *See* 25 Pa. Code §§ 123.1 - 2.

Fugitive dust can affect human health, safety, plant and animal life and public opinion of the mining activity. Special consideration should be given to truck traffic and roads. The movement of vehicles on the mine site can be a major source of air pollution. Water trucks should be utilized along with road graders to maintain haul roads and reduce fugitive dust emissions. Maintaining a durable rock surface on heavily used roads will also minimize dust generation. Calcium chloride and other approved chemicals can be used as a surface application to increase moisture retention of the road surface.

Used motor oil may not be sprayed for dust control due to potential pollution from toxic substances contained in the used oil. Approved grades of virgin or processed recycled oil may be utilized for dust control. Consult the appropriate District Mining Operations office when proposing use of oil for dust control.

REFERENCES

- Barfield, B. J., R. C. Warner, and C. T. Haan, 1983. Applied Hydrology and Sedimentology for Disturbed Areas. Oklahoma Technical Press, Stillwater, Oklahoma. 603 p.
- Beasley, R. P., J. M. Gregory, and T. R. McCarty, 1984. Erosion and Sediment Pollution Control. Iowa State University Press, Des Moines, Iowa. 354 p.
- DER, 1990. Erosion and Sediment Pollution Control Program Manual. Bureau of Soil and Water Conservation.
- DER, 1992. Special Protection Waters Implementation Handbook. Bureau of Water Quality Protection.
- Dietz, J. M., and D. M. Stidinger, 1993. Evaluation of wetlands constructed for the treatment of acidic mine drainage, report to the Department of Environmental Resources (now Department of Environmental Protection), Harrisburg, Pennsylvania.
- EPA, 1982. Development Document for Effluent Limitations Guidelines and Standards for the Coal Mining Point Source Category. Office of Water, Effluent Guidelines Division, Washington, D.C. 408 p.
- EPA, 1976. Erosion and Sediment Control, Surface Mining in the Eastern U.S. - Planning. 102 p.
- Geyer, A. R. and J. P. Wilshusen, 1982. Engineering Characteristics of the Rocks of Pennsylvania. DER, Bureau of Topographic and Geologic Survey. 300 p.
- Goldman, S. J., K. Jackson, and T. A. Bursztynsky, 1986. Erosion & Sediment Control Handbook. McGraw-Hill, New York.
- Gray, P. H. and A. T. Leiser, 1982. Biotechnical Slope Protection and Erosion Control. Van Nostrand, Reinhold, New York.
- Harvard University, 1970. Oxygenation of Ferrous Iron (U.S. Department of the Interior, Federal Water Quality Administration, Contract PH 36-66-107), U.S. Government Printing Office, Washington D.C.
- Hedin, R. S., 1989. Treatment of coal mine drainage with constructed wetlands. U.S. Bureau of Mines, Pittsburgh Research Center. In: Wetlands Ecology and Conservation: Emphasis in Pennsylvania, edited by S. K. Majumdar, R. P. Brooks, F. J. Brenner, and R.W. Tiner, Jr., Pennsylvania Academy of Science, Easton, Pennsylvania.
- Hedin, R. S., Nairn, R.W, and Kleinmann, R. L. P., 1994. U.S. Bureau of Mines, Information Circular IC 9389, "Passive treatment of coal mine drainage," U.S. Bureau of Mines, Washington, D.C.
- Hedin, R.S., and G.R. Watzlaf, 1994. The Effects of Anoxic Limestone Drains on Mine Water Chemistry. Vol. 1, pp. 185-194 in Proceedings: International Land Reclamation and Mine Drainage Conference and International Conference on the Abatement of Acidic Drainage, U.S. Department of the Interior, Bureau of Mines SP 06A-94, Washington, D.C.

FOR DISCUSSION PURPOSES ONLY (AGGREGATE ADVISORY BOARD)

- Hellier, W. W., 1989. Constructed wetlands in Pennsylvania - an overview. Department of Environmental Resources, Bureau of Mining and Reclamation, Paper presented at International Conference on Biohydrometallurgy, Jackson Hole, Wyoming.
- Hellier, W.W., 1994. "Best Professional Judgment Analysis for the Treatment of Post-mining Discharges from Surface Mining Activities." Commonwealth of Pennsylvania, Department of Environmental Protection, Harrisburg, Pennsylvania.
- Hellier, W.W., 1996. The Bark Camp Run demonstration constructed wetlands: findings and recommendations for future design criteria. Report to U.S. EPA. PA Department of Environmental Protection, Harrisburg, Pennsylvania.
- Hellier, W.W., 1996. The Bark Camp Run demonstration constructed wetlands: findings and recommendations for future design criteria. p 550-559 in Proceedings: Thirteenth Annual Meeting, American Society for Surface Mining and Reclamation, May 18-23, 1996, Knoxville, Tennessee.
- Hersfield, D. M., 1961. Rainfall Frequency Atlas of the United States. U.S. Weather Bureau Technical Paper 40.
- Hustwit, C.C., T.E. Ackman, and P.M. Erickson, 1992. Role of Oxygen Transfer in Acid Mine Drainage Treatment. U.S. Department of the Interior RI 9405, U.S. Government Printing Office, Washington D.C.
- Loper, C. A. and K. L. Wetzel, 1988. Sediment Loads, Discharges, and Yields in the East Branch Mahoning Creek Basin, Clearfield and Jefferson Counties, Pennsylvania, June 1979 Through September 1981. U.S. Geological Survey, Water-Resources Investigations Report 85-4213, Harrisburg, Pennsylvania. 26 p.
- Lovell, H, 1973. An Appraisal of Neutralization Processes to Treat Coal Mine Drainage. EPA-670/2-73-093.
- National Crushed Stone Association, 1982. Quarried Stone For Erosion and Sediment Control. National Crushed Stone Association, 1415 Elliot Place N.W., Washington, D.C. 20007. 32 p.
- OSM, 1988. Surface and Groundwater Training Course Manual.
- PennDOT, Construction Specifications Publication 408.
- Pennsylvania State University, Cooperative Extension Service, 1987. Fish Ponds, Construction and Management in Pennsylvania, Special Circular 263, Natural Resources Series 437 Agricultural Administration Bldg., University Park, Pennsylvania.
- Reed, L. A. and R. A. Hainly, 1989. Suspended-Sediment Yields from an Unmined Area and from Mined Areas before and After Reclamation in Pennsylvania, June 1978-September 1983. U.S. Geological Survey, Water-Resources Investigation Report 88-4005. Harrisburg, Pennsylvania. 50 p.

FOR DISCUSSION PURPOSES ONLY (AGGREGATE ADVISORY BOARD)

Sievers, D. M., G. L. Lentz, and R. P. Beasley, 1970. Movement of Agricultural Fertilizers and Organic Insecticides in Surface Runoff. *Trans. American Society of Agricultural Engineers* 13(3). p. 323-325.

Skousen, J., 1990. An Evaluation of Acid Mine Drainage Treatment Systems and Costs, in *Proceedings: Society for Mining Engineers*.

Skousen, J., 1989. Chemicals for treating acid mine drainage, *Green Lands Quarterly*, Vol. 18, No. 3, Fall, pp. 36-40, published by the West Virginia Mining and Reclamation Association.

Stares, D. J., 1989. Coal mining effluent limitations, in *Proceedings: A Conference on State Surface Mining Regulation*, May 1989, Richmond, Virginia. 8 p.

Stumm, W. and F.G. Lee, 1961. Oxygenation of Ferrous Iron. *Industrial and Engineering Chemistry* v. 53 No. 2, pp. 143-146.

Sung, W., and J.J. Morgan, 1980. Kinetics and Product of Ferrous Iron Oxygenation in Aqueous Systems. *Environmental Science and Technology* v. 14, No. 5, pp. 561-568.

USDA, Natural Resources Conservation Service, 1985. Earth Dams and Reservoirs. Technical Release No. 60.

USDA, Natural Resources Conservation Service, 1972. Estimating Rainfall-Erosion Soil Losses on Construction Sites and Similarly Disturbed and Unvegetated Areas in Pennsylvania, 30 p.

USDA, Natural Resources Conservation Service, 1969. Engineering Field Manual F for Conservation Practices.

USDI, Bureau of Reclamation, 1977. Design of Small Dams. U.S. Government Printing Office, Washington, D.C. 816 p.

Wischmeier, W. H. and D. D. Smith, 1965. Predicting Rainfall Losses from Cropland East of the Rocky Mountains. U.S.D.A., Agricultural Handbook 282, 47 p.

The following publications are available from the National Technical Information Service.

Engineering Field Manual, USDA, NRCS PB-85-175164/As

Technical Release No. 55, PB-87-101580/As

Technical Release No. 55, PB-87-101598/As

Design of Roadside Channels with Flexible Linings, PB-89-122584/As

Hydraulic Design of Highway Culverts, PB-86-196961/As

Hydraulic Design of Energy Dissipaters, PB-86-180205/As (Hydraulic Engineering Circular No. 14)

DRAFT

APPENDIX A

DRAFT

Table A.1: Unit Weights of Different Materials (Geyer and Wilshusen, 1982)

Material	English Units	SI Units
Water	62.4 lb/ft ³	1.00 g/cm ³
Water	8.34 lb/gal	1.00 kg/L
Anthracite coal (processed)	50 to 55 lb/ft ³	0.80 to 0.88 g/cm ³
Anthracite coal (in ground)	90 to 100 lb/ft ³	1.44 to 1.60 g/cm ³
Anthracite silt	40 to 44 lb/ft ³	0.64 to 0.71 g/cm ³
Bituminous coal (loose)	68 lb/ft ³	1.09 g/cm ³
Bituminous coal (in ground)	80 lb/ft ³	1.28 g/cm ³
Fly ash (maximum dry density)	75 to 107 lb/ft ³	1.20 to 1.72 g/cm ³
Shale	134 to 165 lb/ft ³	2.15 to 2.65 g/cm ³
Silty shale	145 to 169 lb/ft ³	2.33 to 2.71 g/cm ³
Sandy shale	154 to 167 lb/ft ³	2.47 to 2.67 g/cm ³
Indurated clay	131 to 170 lb/ft ³	2.10 to 2.73 g/cm ³
Claystone	148 to 164 lb/ft ³	2.37 to 2.63 g/cm ³
Siltstone	149 to 166 lb/ft ³	2.39 to 2.66 g/cm ³
Limestone	162 to 178 lb/ft ³	2.60 to 2.85 g/cm ³
Sandstone	165 to 169 lb/ft ³	2.65 to 2.71 g/cm ³

Table A.2: Estimated Quantities

Material	Basis	English	SI
Coal	80 lb/ft ³	1,742 T ac ⁻¹ ft ⁻¹	12,826 t ha ⁻¹ m ⁻¹
Shale	167 lb/ft ³	3,637 T ac ⁻¹ ft ⁻¹	26,775 t ha ⁻¹ m ⁻¹
Sandstone	168.5 lb/ft ³	3,670 T ac ⁻¹ ft ⁻¹	27,015 t ha ⁻¹ m ⁻¹
Siltstone	172 lb/ft ³	3,746 T ac ⁻¹ ft ⁻¹	27,577 t ha ⁻¹ m ⁻¹
Limestone	113.52 lb/ft ³	2,472 T ac ⁻¹ ft ⁻¹	18,201 t ha ⁻¹ m ⁻¹
Crushed limestone	110.19 lb/ft ³	200 T ac ⁻¹ ft ⁻¹	17,667 t ha ⁻¹ m ⁻¹

Table A.3: Estimated Quantity of Bituminous Coal in Place

T/ac; basis 80 lb/ft ³									
feet	0	1	2	3	4	5	6	7	feet
in									in
0	0	1,742	3,485	5,227	6,970	8,712	10,545	12,197	0
1	145	1,880	3,630	5,372	7,115	8,857	10,600	12,342	1
2	290	2,033	3,775	5,518	7,260	9,002	10,745	12,487	2
3	436	2,178	3,920	5,663	7,405	9,148	10,890	12,632	3
4	581	2,323	4,066	5,808	7,550	9,293	11,035	12,778	4
5	726	2,468	4,211	5,953	7,696	9,438	11,180	12,923	5
6	871	2,614	4,356	6,098	7,841	9,583	11,326	13,068	6
7	1,061	2,759	4,501	6,244	7,986	9,728	11,471	13,213	7
8	1,162	2,904	4,646	6,389	8,131	9,874	11,616	13,538	8
9	1,307	3,049	4,792	6,534	8,276	10,103	11,761	13,504	9
10	1,452	3,194	4,937	6,679	8,422	10,164	11,906	13,649	10
11	1,597	3,340	5,082	6,824	8,567	10,309	12,052	13,794	11

T/ac, basis 1.29 g/cm ³									
m	0.0	0.3	0.6	0.9	1.2	1.5	1.8	2.1	m
cm									cm
0.0	0	3,909	7,819	11,728	15,639	19,547	23,456	27,367	0.0
2.5	325	4,218	8,145	12,053	15,964	19,873	23,783	29,692	2.5
5.1	651	4,561	8,470	12,381	16,289	20,198	24,109	28,017	5.1
7.6	978	4,887	8,795	12,706	16,615	20,526	24,434	28,343	7.6
10.2	1,304	5,212	9,123	13,032	16,940	20,851	24,759	28,670	10.2
12.7	1,629	5,537	9,448	13,357	17,268	21,176	25,085	28,996	12.7
15.2	1,954	5,865	9,774	13,682	17,593	21,502	25,412	29,321	15.2
17.8	2,381	6,190	10,099	14,010	17,918	21,827	25,738	29,646	17.8
20.3	2,607	6,516	10,424	14,335	18,244	22,154	26,063	30,375	20.3
22.9	2,933	6,841	10,752	14,660	18,569	22,682	26,388	30,299	22.9
25.4	3,258	7,166	11,077	14,986	18,897	22,805	26,714	30,624	25.4
27.9	3,583	7,494	11,403	15,311	19,222	23,130	27,041	30,950	27.9

Temperature:

- $F = 32 + 9C/5$
- $C = 5(F-32)/9$
- $K = 273.16 + C$
- $R = 459.69 + F$

Energy:

- 1 BTU = 0.252 kcal
- 1 kcal = 3.968 BTU

DRAFT

APPENDIX B

DRAFT

Units and Conversions

The International System of Units (SI, *Système International*) is a coherent system understood readily by all, because there is only one base unit for each physical quantity. Units for all other quantities are derived from these base units by simple equations.

SI is constructed from seven base units for independent quantities plus two supplementary units for plane and solid angles. Most physicochemical quantities can be expressed in terms of these units. The units are given in Table B.1.

Table B.1: Base Units in *Système International*

Physical Quantity	Unit	Symbol
electric current	ampere	A
luminous intensity	candela	cd
thermodynamic temperature	kelvin	K
mass	kilogram	kg
length	meter	m
amount of substance	mole	mol
time	second	s
plane angle	radian	rad
solid angle	steradian	sr

The units are given multiplying prefixes to simplify reporting and conversation. These standard prefixes are given in Table B.2:

Table B.2: Multiplying Prefixes in *Système International*

Factor	Prefix	Symbol	Factor	Prefix	Symbol
10^{-18}	atto	a	10^1	deca	da
10^{-15}	femto	f	10^2	hecto	h
10^{-12}	pico	p	10^3	kilo	k
10^{-9}	nano	n	10^6	mega	M
10^{-6}	micro	μ	10^9	giga	G
10^{-3}	milli	m	10^{12}	tera	T
10^{-2}	centi	c	10^{15}	peta	P
10^{-1}	deci	d	10^{18}	exa	e

FOR DISCUSSION PURPOSES ONLY (AGGREGATE ADVISORY BOARD)

The Department recognizes that most people dealing with mining operations are more familiar with the English system, and that most maps, measuring devices, price quotations, and pieces of equipment use English units. Accordingly, this Appendix provides a set of conversion tables.

Table B.3: Length Conversions

English unit	Symbol		Factor		SI unit	Symbol
mile	mi	=	1.6093	x	kilometer	km
yard	yd	=	0.9144	x	meter	m
foot	ft	=	0.3048	x	meter	m
inch	in	=	2.5400	x	centimeter	cm
inch	in	=	25.4000	x	millimeter	mm
SI unit	Symbol		Factor		English unit	Symbol
kilometer	km	=	0.6214	x	mile	mi
meter	m	=	1.0936	x	yard	yd
meter	m	=	3.2808	x	foot	ft
meter	m	=	39.3701	x	inch	in
centimeter	cm	=	0.3937	x	inch	in
millimeter	mm	=	0.0394	x	inch	in

Table B.4: Area Conversions

Derived unit	Symbol		Factor		English unit	Symbol
acre	ac	=	43560	x	square foot	ft ²
square mile	mi ²	=	640	x	acre	ac
square foot	ft ²	=	144	x	square inch	in ²
English unit	Symbol		Factor		SI unit	Symbol
acre	ac	=	0.4047	x	hectare	ha
acre	ac	=	4047	x	square meter	m ²
acre	ac	=	4.047 x 10⁻³	x	square kilometer	km ²
square mile	mi ²	=	2.5900	x	square kilometer	km ²
square yard	yd ²	=	0.8361	x	square meter	m ²
square foot	ft ²	=	0.0929	x	square meter	m ²
square inch	in ²	=	6.4516	x	square centimeter	cm ²
SI unit	Symbol		Factor		English unit	Symbol
hectare	ha	=	2.4711	x	acre	ac
square kilometer	km ²	=	0.3861	x	square mile	mi ²
square meter	m ²	=	1.1960	x	square yard	yd ²
square meter	m ²	=	10.7639	x	square foot	ft ²
square centimeter	cm ²	=	0.1550	x	square inch	in ²
Derived unit	Symbol		Factor		SI unit	Symbol
hectare	ha	=	104	x	square meter	m ²

DRAFT

Table B.5: Volume Conversions

Derived unit	Symbol		Factor		English unit	Symbol
gallon	gal	=	231	x	cubic inch	in ³
gallon	gal	=	0.1337	x	cubic foot	ft ³
acre foot	ac ft	=	3.2585 x 10 ⁵	x	gallon	gal
acre inch	ac in	=	2.7154 x 10 ⁴	x	gallon	gal
English unit	Symbol		Factor		SI unit	Symbol
gallon	gal	=	3.7854 x 10 ⁻³	x	cubic meter	m ³
gallon	gal	=	3.7854	x	liter	L
quart	qt	=	0.9464	x	liter	L
cubic yard	yd ³	=	0.7646	x	cubic meter	m ³
cubic foot	ft ³	=	0.02832	x	cubic meter	m ³
cubic inch	in ³	=	16.3871	x	cubic centimeter	cm ³
acre inch	ac in	=	102.7948	x	cubic meter	m ³
acre foot	ac ft	=	0.1233	x	hectare meter	ha m
acre foot	ac ft	=	12.3348	x	hectare centimeter	ha cm
SI unit	Symbol		Factor		English unit	Symbol
cubic meter	m ³	=	264.1728	x	gallon	gal
liter	L	=	0.2642	x	gallon	gal
liter	L	=	1.0567	x	quart	qt
cubic meter	m ³	=	1.3080	x	cubic yard	yd ³
cubic meter	m ³	=	35.3147	x	cubic foot	ft ³
cubic centimeter	cm ³	=	0.0610	x	cubic inch	in ³
cubic meter	m ³	=	9.7286 x 10 ⁻³	x	acre inch	ac in
hectare meter	ha m	=	8.1073	x	acre foot	ac ft
hectare centimeter	ha cm	=	0.0811	x	acre foot	ac ft
Derived unit	Symbol		Factor		SI unit	Symbol
liter	L	=	1000	x	cubic centimeter	cm ³
liter	L	=	.001	x	cubic meter	m ³

Table B.6: Mass Conversions

English unit	Symbol		Factor		SI unit	Symbol
US Tons	T	=	0.90718	x	Tonnes (metric tons)	t
pound mass	lbm	=	0.45359	x	kilogram	kg
pound mass	lbm	=	4.5359×10^5	x	milligram	mg
ounce mass	ozm	=	28.3495	x	gram	g
ounce mass	ozm	=	28350	x	milligram	mg
SI unit	Symbol		Factor		English unit	Symbol
Tonnes (metric tons)	t	=	1.1023	x	US Tons	T
kilogram	kg	=	2.2046	x	pound mass	lbm
milligram	mg	=	2.2046×10^{-6}	x	pound mass	lbm
gram	g	=	0.03527	x	ounce mass	ozm
milligram	mg	=	3.5274×10^{-5}	x	ounce mass	ozm

Table B.7: Soil amendments application rates are given as a mass per unit area, not to be confused with a pressure, which is a force per unit area.

Table B.7: Yield or Application Rate Conversions

English unit	Symbol		Factor		SI unit	Symbol
US Tons per acre	T/ac	=	2.2417	x	Tonnes per hectare	t/ha
US Tons per acre	T/ac	=	0.22417		kilograms per square meter	kg/m ²
pounds mass per acre	lbm/ac	=	1.1219		kilograms per hectare	kg/ha
SI unit	Symbol		Factor		English unit	Symbol
Tonnes per hectare	t/ha	=	0.4461	x	US Tons per acre	T/ac
kilograms per square meter	kg/m ²	=	4.4609	x	US Tons per acre	T/ac
kilograms per hectare	kg/ha	=	0.8922	x	pounds mass per acre	lbm/ac

Weight is a force, and force is defined as the time rate of change of momentum. If mass is constant, force equals mass times acceleration. There is often confusion between mass and weight. In SI, there is less confusion, because weight is expressed in newtons (N); and represents a mass of 1 kg accelerated at 9.8068 m/sec^2 when measured at average conditions at the earth's surface. The term "pound" is used interchangeably in the English system to represent both weight and mass. Technically, a pound (weight) is a mass of one slug accelerated at $32.174 \text{ feet/sec}^2$. Then $(32.174 \text{ slug feet sec}^{-2}) = 1 \text{ lbf}$ and $32.174 \text{ slug feet sec}^{-2} \text{ lbf}^{-1}$ is the pure number 1. Because virtually nobody uses the technical term slug in everyday conversation, the term slug has been replaced by the term "pound mass," or lbm. It is this lbm which is equal to 0.454 kg. It is extremely important to keep mass and weight (force) straight when

FOR DISCUSSION PURPOSES ONLY (AGGREGATE ADVISORY BOARD)

calculating pressure, which is defined as a force per unit area, not a mass per unit area. Use the conversion $1 = 32.174 \text{ lbf} \cdot \text{ft} / \text{lbm} \cdot \text{sec}^2$, often designated as gc. Atmospheric pressure is 14.70 lbf/ft^2 .

Table B.3: Pressure (Head) Conversions

English unit	Symbol		Factor		SI unit	Symbol
pounds per square inch	lbf/in ² or psi	=	6894.8	x	Pascal	Pa
pounds per square foot	lbf/ft ²	=	47.88	x	Pascal	Pa
inches of mercury	in Hg	=	25.4		millimeters of mercury	mm Hg
feet of water	ft H ₂ O	=	0.3048	x	meters of water	m H ₂ O
SI unit	Symbol		Factor		English unit	Symbol
Pascal	Pa	=	1.450×10^{-4}	x	pounds per square inch	lbf/in ² or psi
Pascal	Pa	=	0.02089	x	pounds per square foot	lbf/ft ²
millimeters of mercury	mm Hg	=	0.03937	x	inches of mercury	in Hg
meters of water	m H ₂ O	=	3.2808	x	feet of water	ft H ₂ O

Table B.9: Flow Rate Conversions

English unit	Symbol		Factor		SI unit	Symbol
cubic feet per second	ft ³ /sec or cfs	x	26344.72	=	cubic meters per day	m ³ /day
cubic feet per minute	ft ³ /min or cfm	x	439.08	=	cubic meters per day	m ³ /day
gallons per minute	gal/min or gpm	x	5.45099	=	cubic meters per day	m ³ /day
gallons per minute	ft ³ /sec or cfs	x	5450.99	=	liters per day	L/day
million gallons per day	10 ⁶ gal/day or MGD	x	3785.41	=	cubic meters per day	m ³ /day
SI unit	Symbol		Factor		English unit	Symbol
cubic meters per day	m ³ /day	x	3.7958 x 10 ⁻⁵	=	cubic feet per second	ft ³ /sec or cfs
cubic meters per day	m ³ /day	x	2.2775 x 10 ⁻³	=	cubic feet per minute	ft ³ /min or cfm
cubic meters per day	m ³ /day	x	0.1835	=	gallons per minute	gal/min or gpm
liters per day	L/day	x	1.8345 x 10 ⁻⁴	=	gallons per minute	ft ³ /sec or cfs
cubic meters per day	m ³ /day	x	2.5804 x 10 ⁻⁴	=	million gallons per day	10 ⁶ gal/day or MGD

Note:

One (1) mg/L is the same as 1 lb per million pounds of water; i.e., 1 part of pollutant per million parts of water by weight. When the concentrations of pollutants are relatively low, parts per million and mg/l are essentially equivalent.”

A concentration of 1,000 pounds of pollutant per million pounds of solution would be (1,000/1.001) parts per million, or 999 parts per million (999 mg/L) Thus saying “parts per million” interchangeably with “mg/L” results in a 0.1 percent error, which is usually less than the error involved in measurement.

Table B.10: Density Conversions

English unit	Symbol		Factor		SI unit	Symbol
pounds per gallon	lbm/gal	x	119934	=	grams per cubic meter equivalently, milligrams per liter	g/m ³ or mg/L
pounds per cubic inch	lbm/in ³	x	27680	=	kilograms per cubic meter	kg/m ³
pounds per cubic foot	lbm/ft ³	x	16.01837	=	kilograms per cubic meter	kg/m ³
pounds per cubic yard	lbm/yd ³	x	0.5933	=	kilograms per cubic meter	kg/m ³
US tons per cubic yard	T/yd ³	x	1.1865	=	tonnes per cubic meter	t/m ³
SI unit	Symbol		Factor		English unit	Symbol
milligrams per liter	mg/L		10 ⁻⁶		pounds per million pounds of H ₂ O	
grams per cubic meter equivalently, milligrams per liter	g/m ³ or mg/L	x	8.3379 x 10 ⁻⁶	=	pounds per gallon	lbm/gal
kilograms per cubic meter	kg/m ³	x	3.6127 x 10 ⁻⁵	=	pounds per cubic inch	lbm/in ³
kilograms per cubic meter	kg/m ³	x	0.06243	=	pounds per cubic foot	lbm/ft ³
kilograms per cubic meter	kg/m ³	x	1.6856	=	pounds per cubic yard	lbm/yd ³
tonnes per cubic meter	t/m ³	x	0.8428	=	US tons per cubic yard	T/yd ³

Table B.11: Velocity Conversions

English unit	Symbol		Factor		SI unit	Symbol
miles per hour	mi/hr	x	0.44704	=	meters per second	m/sec
feet per second	ft/sec	x	0.3048	=	meters per second	m/sec
SI unit	Symbol		Factor		English unit	Symbol
meters per second	m/sec	x	2.2369	=	miles per hour	mi/hr
meters per second	m/sec	x	3.2808	=	feet per second	ft/sec

FOR DISCUSSION PURPOSES ONLY (AGGREGATE ADVISORY BOARD)

Slope Measurements

Slope is the change in vertical distance divided by the change in horizontal distance. For instance, a two percent slope on a ditch means that the elevation drops two feet for 100 feet traveled. The percent grade can be calculated by multiplying the slope by 100 and expressing it as a percentage.

However, the term “slope” as it is used in discussions dealing with embankments and other civil engineering features within this manual, is actually the change in horizontal distance divided by the change in vertical distance, or the cotangent of the angle θ . For instance, a 3:1 slope on an embankment means that the embankments decrease one foot vertically for every three feet of horizontal distance and is expressed as a ratio.

Table B.12: Slope Equivalents

Horizontal distance = X	Vertical distance = Z	Tangent = z/x	Percent Grade	Cotangent (slope) = x/y	Angle from Horizontal (degrees)
0.50	1.00	2.000	200.00	0.50	63.43
1.00	1.00	1.000	100.00	1.00	45.00
1.50	1.00	0.6667	66.67	1.50	33.69
2.00	1.00	0.5000	50.00	2.00	26.57
2.50	1.00	0.4000	40.00	2.50	21.80
3.00	1.00	0.3333	33.33	3.00	18.43
3.50	1.00	0.2857	28.57	3.50	15.95
4.00	1.00	0.2500	25.00	4.00	14.04
4.50	1.00	0.2222	22.22	4.50	12.53
5.00	1.00	0.2000	20.00	5.00	11.31
5.50	1.00	0.1818	18.18	5.50	10.30
6.00	1.00	0.1667	16.67	6.00	9.46
6.50	1.00	0.1538	15.38	6.50	8.75
7.00	1.00	0.1429	14.29	7.00	8.13
7.50	1.00	0.1333	13.33	7.50	7.59
8.00	1.00	0.1250	12.50	8.00	7.13
8.50	1.00	0.1176	11.76	8.50	6.71
9.00	1.00	0.1111	11.11	9.00	6.34
9.50	1.00	0.1053	10.53	9.50	6.01
10.00	1.00	0.1000	10.00	10.00	5.71