

Stream ID	Stream Name	Coordinates	Flow Regime	Bank to Bank Width (feet)	Crossing Method	PARC Stream Description	Situation Impaired	E&S Plan Sheet Number
S-884	UNT to James Creek	-78.1275, 40.4010	Perennial	3	Temporary Bridge	na	Yes	ES-308
S-884	UNT to Trout Creek	-78.0432, 40.3024	Intermittent	25	Dry Crossing	na	Yes	ES-327
S-885	UNT to Trout Creek	-78.0432, 40.3024	Intermittent	25	Open Cut Floodway	na	Yes	ES-328
S-886	UNT to Trout Creek	-78.0432, 40.3024	Intermittent	25	Open Cut Floodway	na	Yes	ES-329
S-887	UNT to Trout Creek	-78.0432, 40.3024	Intermittent	25	Open Cut Floodway	na	Yes	ES-330
S-888	UNT to Trout Creek	-78.0432, 40.3024	Intermittent	25	Open Cut Floodway	na	Yes	ES-331
S-889	UNT to Trout Creek	-78.0432, 40.3024	Intermittent	25	Open Cut Floodway	na	Yes	ES-332
S-890	UNT to Trout Creek	-78.0432, 40.3024	Intermittent	25	Open Cut Floodway	na	Yes	ES-333
S-891	UNT to Trout Creek	-78.0432, 40.3024	Intermittent	25	Open Cut Floodway	na	Yes	ES-334
S-892	UNT to Trout Creek	-78.0432, 40.3024	Intermittent	25	Open Cut Floodway	na	Yes	ES-335
S-893	UNT to Trout Creek	-78.0432, 40.3024	Intermittent	25	Open Cut Floodway	na	Yes	ES-336
S-894	UNT to Trout Creek	-78.0432, 40.3024	Intermittent	25	Open Cut Floodway	na	Yes	ES-337
S-895	UNT to Trout Creek	-78.0432, 40.3024	Intermittent	25	Open Cut Floodway	na	Yes	ES-338
S-896	UNT to Trout Creek	-78.0432, 40.3024	Intermittent	25	Open Cut Floodway	na	Yes	ES-339
S-897	UNT to Trout Creek	-78.0432, 40.3024	Intermittent	25	Open Cut Floodway	na	Yes	ES-340
S-898	UNT to Trout Creek	-78.0432, 40.3024	Intermittent	25	Open Cut Floodway	na	Yes	ES-341
S-899	UNT to Trout Creek	-78.0432, 40.3024	Intermittent	25	Open Cut Floodway	na	Yes	ES-342
S-900	UNT to Trout Creek	-78.0432, 40.3024	Intermittent	25	Open Cut Floodway	na	Yes	ES-343
S-901	UNT to Trout Creek	-78.0432, 40.3024	Intermittent	25	Open Cut Floodway	na	Yes	ES-344
S-902	UNT to Trout Creek	-78.0432, 40.3024	Intermittent	25	Open Cut Floodway	na	Yes	ES-345
S-903	UNT to Trout Creek	-78.0432, 40.3024	Intermittent	25	Open Cut Floodway	na	Yes	ES-346
S-904	UNT to Trout Creek	-78.0432, 40.3024	Intermittent	25	Open Cut Floodway	na	Yes	ES-347
S-905	UNT to Trout Creek	-78.0432, 40.3024	Intermittent	25	Open Cut Floodway	na	Yes	ES-348
S-906	UNT to Trout Creek	-78.0432, 40.3024	Intermittent	25	Open Cut Floodway	na	Yes	ES-349
S-907	UNT to Trout Creek	-78.0432, 40.3024	Intermittent	25	Open Cut Floodway	na	Yes	ES-350
S-908	UNT to Trout Creek	-78.0432, 40.3024	Intermittent	25	Open Cut Floodway	na	Yes	ES-351
S-909	UNT to Trout Creek	-78.0432, 40.3024	Intermittent	25	Open Cut Floodway	na	Yes	ES-352
S-910	UNT to Trout Creek	-78.0432, 40.3024	Intermittent	25	Open Cut Floodway	na	Yes	ES-353
S-911	UNT to Trout Creek	-78.0432, 40.3024	Intermittent	25	Open Cut Floodway	na	Yes	ES-354
S-912	UNT to Trout Creek	-78.0432, 40.3024	Intermittent	25	Open Cut Floodway	na	Yes	ES-355
S-913	UNT to Trout Creek	-78.0432, 40.3024	Intermittent	25	Open Cut Floodway	na	Yes	ES-356
S-914	UNT to Trout Creek	-78.0432, 40.3024	Intermittent	25	Open Cut Floodway	na	Yes	ES-357
S-915	UNT to Trout Creek	-78.0432, 40.3024	Intermittent	25	Open Cut Floodway	na	Yes	ES-358
S-916	UNT to Trout Creek	-78.0432, 40.3024	Intermittent	25	Open Cut Floodway	na	Yes	ES-359
S-917	UNT to Trout Creek	-78.0432, 40.3024	Intermittent	25	Open Cut Floodway	na	Yes	ES-360
S-918	UNT to Trout Creek	-78.0432, 40.3024	Intermittent	25	Open Cut Floodway	na	Yes	ES-361
S-919	UNT to Trout Creek	-78.0432, 40.3024	Intermittent	25	Open Cut Floodway	na	Yes	ES-362
S-920	UNT to Trout Creek	-78.0432, 40.3024	Intermittent	25	Open Cut Floodway	na	Yes	ES-363
S-921	UNT to Trout Creek	-78.0432, 40.3024	Intermittent	25	Open Cut Floodway	na	Yes	ES-364
S-922	UNT to Trout Creek	-78.0432, 40.3024	Intermittent	25	Open Cut Floodway	na	Yes	ES-365

Stream ID	Stream Name	Coordinates	Flow Regime	Bank to Bank Width (feet)	Crossing Method	PARC Stream Description	Situation Impaired	E&S Plan Sheet Number
S-Y10	UNT to James Creek	-78.1048, 40.3902	Epithermal	2	Dry Crossing	na	No	ES-314
S-Y11	UNT to James Creek	-78.1044, 40.3903	Perennial	6	Dry Crossing	na	No	ES-314
S-Y12	UNT to James Creek	-78.1021, 40.3909	Epithermal	4	Dry Crossing	na	No	ES-315
S-Y13	UNT to James Creek	-78.1011, 40.3950	Epithermal	6	Open Cut Floodway	na	No	ES-318
S-Y14	UNT to Raystown Lake	-78.0926, 40.3676	Epithermal	6	Dry Crossing	na	No	ES-310
S-Y15	UNT to Raystown Lake	-78.0864, 40.3557	Epithermal	4	Dry Crossing	na	No	ES-317, 318
S-Y16	UNT to Raystown Lake	-78.0841, 40.3557	Perennial	12	Dry Crossing	na	No	ES-318
S-Y17	UNT to Raystown Lake	-78.0841, 40.3557	Epithermal	6	Open Cut Floodway	na	No	ES-318
S-Y18	UNT to Raystown Lake	-78.0864, 40.3557	Epithermal	6	Open Cut Floodway	na	No	ES-318, 319
S-Y19	UNT to Raystown Lake	-78.0794, 40.3807	Perennial	6	Dry Crossing	na	No	ES-319
S-Y20	UNT to Raystown Lake	-78.0792, 40.3803	Epithermal	3	Dry Crossing	na	No	ES-319, 320
S-M99	UNT to Raystown Lake	-78.0801, 40.3769	Intermittent	3	Open Cut Floodway	na	No	ES-320
S-Y21	UNT to Raystown Branch Junata River	-78.1644, 40.4041	Epithermal	3	Open Cut Floodway	na	No	ES-303
S-Y22	UNT to Raystown Branch Junata River	-78.1560, 40.3964	Perennial	21	Dry Crossing	na	No	ES-305

Wetland ID	USFWS Cowardin Classification	Coordinates	Crossing Method	Exceptional Value	E&S Plan Sheet Number
W332	PEM	-77.7548, 40.3143	Open Cut	Wild Trout Trib	ES-3.79
W333	PEM	-77.7545, 40.3143	Open Cut	Wild Trout Trib	ES-3.79
W46B	PSS	-77.8527, 40.3429	HDD	n/a	ES-3.61
BB127	PSS	-77.9903, 40.3536	Open Cut	n/a	ES-3.37
	PEM	-77.9901, 40.3537	Open Cut	n/a	ES-3.37
	PFO	-77.9899, 40.3537	Open Cut	n/a	ES-3.37
CC27	PEM	-77.8668, 40.3451	Open Cut	n/a	ES-3.58
CC28	PFO	-78.1166, 40.3932	Open Cut/Temporary Matting	n/a	ES-3.12
K63	PEM	-77.7260, 40.3074	Open Cut	Wild Trout Trib	ES-3.84
K65	PEM	-77.7373, 40.3104	Open Cut	Wild Trout Trib	ES-3.82
K66	PEM	-77.7391, 40.3108	Open Cut	Wild Trout Trib	ES-3.81, 3.82
K67	PEM	-77.7458, 40.3125	Open Cut	Wild Trout Trib	ES-3.80
K68	PEM	-77.7487, 40.3131	Travel Only	Wild Trout Trib	ES-3.80
	PSS	-77.7487, 40.3131	HDD	Wild Trout Trib	ES-3.80
	PSS	-77.7493, 40.3134	HDD	Wild Trout Trib	ES-3.80
K69	PEM	-77.7887, 40.3214	HDD	n/a	ES-3.73
	PSS	-77.7885, 40.3216	HDD	n/a	ES-3.73
K70	PFO	-77.7874, 40.3210	HDD	n/a	ES-3.73
K72	PEM	-77.7818, 40.3198	Open Cut	n/a	ES-3.74
L5	PEM	-77.7558, 40.3145	Open Cut	n/a	ES-3.79
L6	PEM	-77.7572, 40.3148	Open Cut	n/a	ES-3.78
L7	PEM	-77.7591, 40.3151	Open Cut	Wild Trout Trib	ES-3.78
L8	PEM	-77.7603, 40.3154	Open Cut	Wild Trout Trib	ES-3.78
L9	PEM	-77.7633, 40.3159	Open Cut	Wild Trout Trib	ES-3.77
L10	PEM	-77.7802, 40.3196	Open Cut	n/a	ES-3.74
L11	PEM	-77.8311, 40.3346	Open Cut	n/a	ES-3.65
L12	PEM	-77.8306, 40.3345	Open Cut	n/a	ES-3.65
L13	PEM	-77.8304, 40.3344	Open Cut	n/a	ES-3.66
L14	PEM	-77.8276, 40.3331	Open Cut	n/a	ES-3.66
L15	PEM	-77.8624, 40.3452	Open Cut	n/a	ES-3.59
L16	PEM	-77.9405, 40.3431	Open Cut	n/a	ES-3.45, 3.46
L17	PEM	-77.9411, 40.3432	Open Cut	n/a	ES-3.44
L18	PEM	-77.9471, 40.3454	Open Cut	n/a	ES-3.44
L20	PEM	-77.9475, 40.3457	Open Cut	n/a	ES-3.44
L21	PEM	-77.9587, 40.3489	Open Cut	n/a	ES-3.41
L24	PEM	-78.0066, 40.3580	Open Cut	n/a	ES-3.34
L27	PEM	-78.0123, 40.3578	HDD	n/a	ES-3.32, 3.33
	PSS	-78.0121, 40.3580	HDD	n/a	ES-3.32, 3.33
L28	PEM	-78.0186, 40.3588	Open Cut	n/a	ES-3.31
L29	PEM	-78.0231, 40.3595	Open Cut	n/a	ES-3.31
L31	PEM	-78.1664, 40.4055	Open Cut	n/a	ES-3.03
L32	PEM	-78.1662, 40.4051	Open Cut	n/a	ES-3.03
L33	PEM	-77.9472, 40.3452	Open Cut	n/a	ES-3.44
L36	PSS	-78.1446, 40.3965	Open Cut	n/a	ES-3.07
M1	PEM	-77.7911, 40.3218	Open Cut	n/a	ES-3.72
M2	PEM	-77.7944, 40.3223	Open Cut	n/a	ES-3.72
M3	PEM	-77.8011, 40.3236	Open Cut	n/a	ES-3.71
	PSS	-77.8011, 40.3236	Open Cut	n/a	ES-3.71
M6	PEM	-77.8167, 40.3284	Open Cut	n/a	ES-3.68
M7	PEM	-77.8908, 40.3412	Open Cut	n/a	ES-3.54
M8	PEM	-77.8880, 40.3414	Open Cut	n/a	ES-3.55
M9	PEM	-77.8846, 40.3421	Open Cut	n/a	ES-3.55
M10	PEM	-77.8782, 40.3432	Open Cut	n/a	ES-3.56
M12	PEM	-77.8700, 40.3444	Open Cut	n/a	ES-3.58
M13	PEM	-77.9719, 40.3510	Open Cut	n/a	ES-3.40
M15	PEM	-77.9728, 40.3515	Open Cut	n/a	ES-3.40
M17	PEM	-77.9764, 40.3517	Open Cut	n/a	ES-3.39
Y1	PFO	-78.1342, 40.3973	HDD	n/a	ES-3.09
Y2	PSS	-78.1332, 40.3969	HDD	n/a	ES-3.09
Y3	PSS	-78.1325, 40.3966	HDD	n/a	ES-3.09
Y4	PFO	-78.1298, 40.3960	HDD	n/a	ES-3.10
Y6	PFO	-78.1213, 40.3942	HDD	n/a	ES-3.11
Y7	PEM	-78.1200, 40.3937	Travel Only	n/a	ES-3.11, 3.12
	PFO	-78.1198, 40.3936	HDD	n/a	ES-3.11, 3.12
Y12	PEM	-78.0789, 40.3814	Open Cut	n/a	ES-3.19
Y13	PEM	-78.1634, 40.4017	Open Cut	n/a	ES-3.04
Y14	PEM	-78.1569, 40.3966	Open Cut	n/a	ES-3.05
LK-2	Pub	-78.0717, 40.3719	HDD	n/a	ES-3.22
Pond-4	Pub	-78.0104, 40.3578	HDD	n/a	ES-3.33

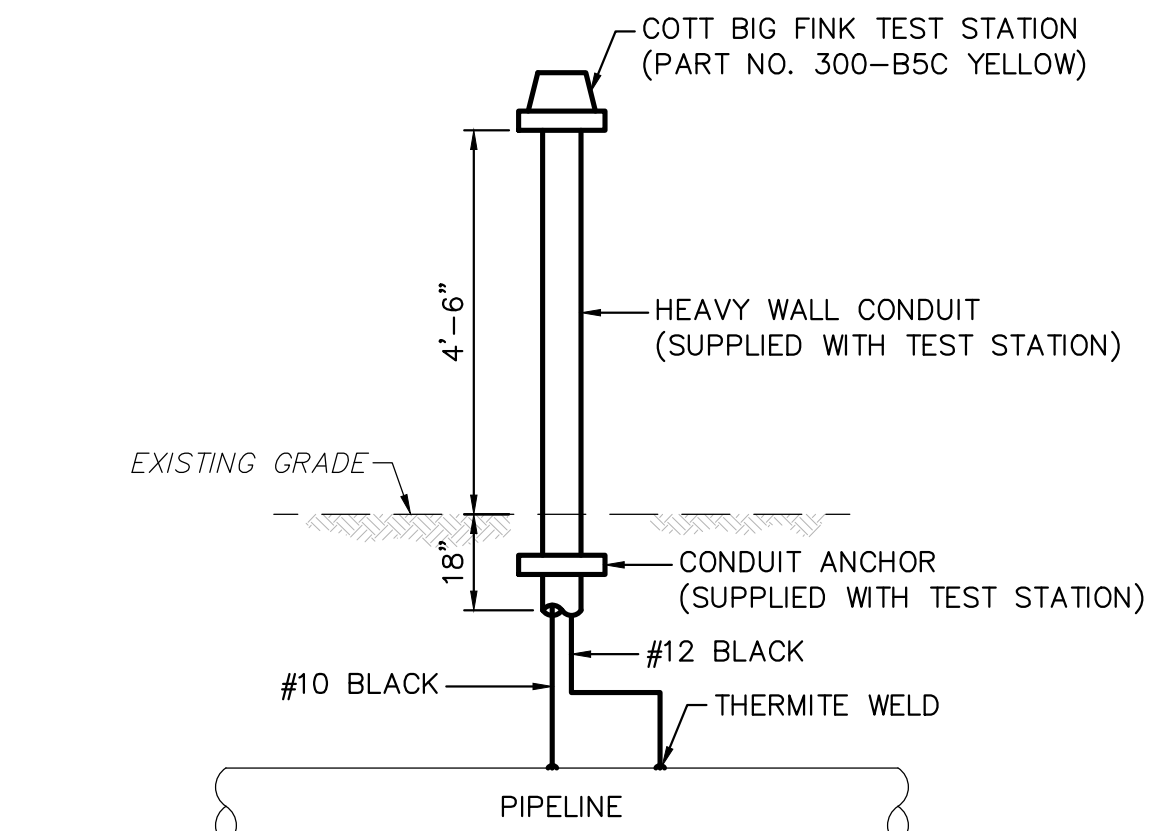

- NOTES:**
- TEST WIRES SHALL BE STRANDED COPPER WITH THW OR MTW INSULATION.
 - TEST WIRES SHALL BE OF THE GAUGE INDICATED AND PROVIDED WITH WIRE LABELS (WITHIN TEST STATION) TO IDENTIFY THE PIPELINE ATTACHMENT LOCATION. THE NO. 1 TEST WIRE SHALL BE ATTACHED TO THE PIPELINE AT THE LOWER STATION NO. WITH THE ADDITIONAL TEST WIRE ATTACHED AT THE SPACING INDICATED AND IN ORDER OF ADVANCING STATION NOS.
 - TEST WIRES ARE TO BE CONNECTED USING THE THERMITE WELD PROCESS.
 - COAT THERMITE WELD CONNECTION & ALL BELOW GRADE EXPOSED COPPER AS SPECIFIED FOR EXISTING PIPELINE COATING OR AS SPECIFIED FOR BARE PIPE.
 - INSTALL TEST WIRES WITHIN PIPE TRENCH AT THE FIVE OR SEVEN O'CLOCK POSITION OF THE PIPE. TEST WIRES SHALL NOT BE IN IMMEDIATE CONTACT WITH THE PIPE.
 - BACK-FILL AROUND WIRES MUST BE FREE OF SHARP MATERIALS WHICH COULD DAMAGE THE TEST WIRE INSULATION.

TYPICAL CATHODIC PROTECTION TEST STATION
NOT TO SCALE

Site Specific Restrictions			
County	E&S Sheet No.	Beginning Station	Ending Station
Indiana Bat ⁽¹⁾	ES-3.01	7006+00	7022+00
	ES-3.02	7024+00	7038+00
	ES-3.03	7038+00	7056+00
	ES-3.04	7058+00	7074+00
	ES-3.05	7074+00	7092+00
	ES-3.06	7092+00	7108+00
	ES-3.07	7110+00	7130+00
	ES-3.08	7132+00	7150+00
	ES-3.09	7150+00	7166+00
	ES-3.10	7166+00	7182+00
	ES-3.11	7184+00	7198+00
	ES-3.12	7200+00	7214+00
	ES-3.13	7218+00	7240+00
	ES-3.14	7244+00	7248+00
	ES-3.15	7250+00	7264+00
	ES-3.16	7266+00	7282+00
	ES-3.17	7282+00	7298+00
	ES-3.18	7300+00	7316+00
	ES-3.19	7314+00	7336+00
	ES-3.20	7338+00	7356+00</

STANDARD EROSION AND SEDIMENT CONTROL PLAN NOTES (CONTINUED):

14. UNTIL THE SITE IS STABILIZED, ALL EROSION AND SEDIMENT BMPs SHALL BE MAINTAINED PROPERLY. MAINTENANCE SHALL INCLUDE INSPECTIONS OF ALL EROSION AND SEDIMENT BMPs AFTER EACH RUNOFF EVENT AND ON A WEEKLY BASIS. ALL PREVENTATIVE AND REMEDIAL MAINTENANCE WORK, INCLUDING CLEAN OUT, REPAIR, REPLACEMENT, REGRADING, RESEEDING, RE-MULCH AND RE-NETTING MUST BE PERFORMED IMMEDIATELY. IF THE E&S BMPs FAIL TO PERFORM AS EXPECTED, REPLACEMENT BMPs, OR MODIFICATIONS OF THOSE INSTALLED WILL BE REQUIRED.
15. NO SOIL AMENDMENTS SUCH AS AGRICULTURAL LIME, FERTILIZER, ETC. WILL BE USED WITHIN WETLAND AREAS.
16. A LOG SHOWING DATES THAT E&S BMPs WERE INSPECTED AS WELL AS ANY DEFICIENCIES FOUND AND THE DATE THEY WERE CORRECTED SHALL BE MAINTAINED ON THE SITE AND BE MADE AVAILABLE TO REGULATORY AGENCY OFFICIALS AT THE TIME OF INSPECTION.
17. SEDIMENT TRACKED ONTO ANY PUBLIC ROADWAY OR SIDEWALK SHALL BE RETURNED TO THE CONSTRUCTION SITE AT THE END OF EACH DAY, OR AS NEEDED, OR AS DIRECTED BY THE CONSERVATION DISTRICT OR LOCAL MUNICIPALITY, AND DISPOSED IN THE MANNER DESCRIBED IN THIS PLAN. IN NO CASE SHALL THE SEDIMENT BE WASHED, SHOVELED, OR SWEEPED INTO ANY ROADSIDE DITCH, STORM SEWER, OR SURFACE WATER.
18. ALL SEDIMENT REMOVED FROM BMPs SHALL BE DISPOSED OF IN THE MANNER DESCRIBED ON THE PLAN DRAWINGS.
19. IN AREAS OF TOPSOIL SEGREGATION THE TOPSOIL SHALL BE SCARIFIED TO A MINIMUM DEPTH OF 3 TO 5 INCHES -- 6 TO 12 INCHES ON COMPACTED SOILS -- PRIOR TO THE RESTORATION OF THE TOPSOIL AREAS TO BE REVEGETATED SHALL HAVE A MINIMUM 4 INCHES OF TOPSOIL IN PLACE PRIOR TO SEEDING AND MULCHING. FILL/OUT SLOPES SHALL HAVE A MINIMUM OF 2 INCHES OF TOPSOIL.
20. ALL FILLS SHALL BE COMPACTED AS REQUIRED TO REDUCE EROSION, SLIPPAGE, SETTLEMENT, SUBSIDENCE OR OTHER RELATED PROBLEMS. FILL INTENDED TO SUPPORT BUILDINGS, STRUCTURES AND CONDUITS, ETC. SHALL BE COMPACTED IN ACCORDANCE WITH LOCAL REQUIREMENTS OR CODES.
21. ALL EARTHEN FILLS SHALL BE PLACED IN COMPACTED LAYERS NOT TO EXCEED 8 INCHES IN THICKNESS.
22. FILL MATERIALS SHALL BE FREE OF FROZEN PARTICLES, BRUSH, ROOTS, SOD, OR OTHER FOREIGN OR OBJECTIONABLE MATERIALS THAT WOULD INTERFERE WITH OR PREVENT CONSTRUCTION OF SATISFACTORY FILLS.
23. FROZEN MATERIALS OR SOFT, MUCKY, OR HIGHLY COMPRESSIBLE MATERIALS SHALL NOT BE INCORPORATED INTO FILLS.
24. FILL SHALL NOT BE PLACED ON SATURATED OR FROZEN SURFACES.
25. SEEPS OR SPRINGS ENCOUNTERED DURING CONSTRUCTION SHALL BE HANDLED IN ACCORDANCE WITH THE STANDARD AND SPECIFICATION FOR SUBSURFACE DRAIN OR OTHER APPROVED METHOD.
26. ALL GRADED AREAS SHALL BE PERMANENTLY STABILIZED IMMEDIATELY UPON REACHING FINISHED GRADE. CUT SLOPES IN COMPETENT BEDROCK AND ROCK FILLS NEED NOT BE VEGETATED. SEEDING AREAS WITHIN 100 FEET OF A SPECIAL PROTECTION SURFACE WATER, OR AS OTHERWISE SHOWN ON THE PLAN DRAWINGS, SHALL BE BLANKETED ACCORDING TO THE STANDARDS OF THIS PLAN.
27. UPON TEMPORARY CESSATION OF AN EARTH DISTURBANCE ACTIVITY OR ANY STAGE OR PHASE OF AN ACTIVITY WHERE CESSATION OF EARTH DISTURBANCE ACTIVITIES IN NON-SPECIAL PROTECTION WATERSHEDS WILL EXCEED 4 DAYS, THE SITE SHALL BE IMMEDIATELY SEEDED, MULCHED OR OTHERWISE PROTECTED FROM ACCELERATED EROSION AND SEDIMENTATION PENDING FUTURE EARTH DISTURBANCE ACTIVITIES IN A SPECIAL PROTECTION WATERSHEDS TEMPORARY STABILIZATION SHALL BE IMMEDIATE.
28. PERMANENT STABILIZATION IS DEFINED AS A MINIMUM UNIFORM, PERENNIAL 70% VEGETATIVE COVER OR OTHER PERMANENT NON-VEGETATIVE COVER WITH A DENSITY SUFFICIENT TO RESIST ACCELERATED EROSION. CUT AND FILL SLOPES SHALL BE CAPABLE OF RESISTING FAILURE DUE TO SLUMPING, SLIDING, OR OTHER MOVEMENTS.
29. E&S BMPs SHALL REMAIN FUNCTIONAL AS SUCH UNTIL ALL AREAS TRIBUTARY TO THEM ARE PERMANENTLY STABILIZED OR UNTIL THEY ARE REPLACED BY ANOTHER BMP APPROVED BY THE LOCAL CONSERVATION DISTRICT OR THE DEPARTMENT.
30. UPON COMPLETION OF ALL EARTH DISTURBANCE ACTIVITIES AND PERMANENT STABILIZATION OF ALL DISTURBED AREAS, THE OWNER AND/OR OPERATOR SHALL CONTACT THE LOCAL CONSERVATION DISTRICT FOR AN INSPECTION PRIOR TO REMOVAL/CONVERSION OF THE E&S BMPs.
31. AFTER FINAL SITE STABILIZATION HAS BEEN ACHIEVED, TEMPORARY EROSION AND SEDIMENT BMPs MUST BE REMOVED OR CONVERTED TO PERMANENT POST CONSTRUCTION STORM WATER MANAGEMENT BMPs. AREAS DISTURBED DURING REMOVAL OR CONVERSION OF THE BMPs SHALL BE STABILIZED IMMEDIATELY. IN ORDER TO ENSURE RAPID REVEGETATION OF DISTURBED AREAS, SUCH REMOVAL/CONVERSIONS ARE TO BE DONE ONLY DURING THE GERMINATING SEASON.
32. UPON COMPLETION OF ALL EARTH DISTURBANCE ACTIVITIES AND PERMANENT STABILIZATION OF ALL DISTURBED AREAS, THE OWNER AND/OR OPERATOR SHALL CONTACT THE LOCAL CONSERVATION DISTRICT TO SCHEDULE A FINAL INSPECTION.
33. FAILURE TO CORRECTLY INSTALL E&S BMPs, FAILURE TO PREVENT SEDIMENT-LADEN RUNOFF FROM LEAVING THE CONSTRUCTION SITE, OR FAILURE TO TAKE IMMEDIATE CORRECTIVE ACTION TO RESOLVE FAILURE OF E&S BMPs MAY RESULT IN ADMINISTRATIVE, CIVIL AND/OR CRIMINAL PENALTIES BEING INSTITUTED BY THE DEPARTMENT AS DEFINED IN SECTION 602 OF THE PENNSYLVANIA CLEAN STREAMS LAW. THE CLEAN STREAMS LAW PROVIDES FOR UP TO \$10,000 PER DAY IN CIVIL PENALTIES, UP TO \$10,000 IN SUMMARY CRIMINAL PENALTIES, AND UP TO \$25,000 IN MISDEMEANOR CRIMINAL PENALTIES FOR EACH VIOLATION.
34. ALL CHANNELS SHALL BE KEPT FREE OF OBSTRUCTIONS INCLUDING BUT NOT LIMITED TO FILL, ROCKS, LEAVES, WOODY DEBRIS, ACCUMULATED SEDIMENT, EXCESS VEGETATION, AND CONSTRUCTION MATERIAL/WASTES.
35. UNDERGROUND UTILITIES CUTTING THROUGH ANY ACTIVE CHANNEL SHALL BE IMMEDIATELY BACKFILLED AND THE CHANNEL RESTORED TO ITS ORIGINAL CROSS-SECTION AND PROTECTIVE LINING. ANY BASE FLOW WITHIN THE CHANNEL SHALL BE CONVEYED PAST THE WORK AREA IN THE MANNER DESCRIBED IN THIS PLAN UNTIL SUCH RESTORATION IS COMPLETE.
36. EROSION CONTROL BLANKETING SHALL BE INSTALLED ON ALL SLOPES 3H:1V OR GREATER AND ALL AREAS, REGARDLESS OF SLOPE WITHIN 50 FEET OF NON-SPECIAL PROTECTION AND 100 FEET OF A SPECIAL PROTECTION SURFACE WATER AND ON ALL OTHER DISTURBED AREAS SPECIFIED ON THE PLAN MAPS AND/OR DETAIL SHEETS.
37. UPON COMPLETION OR TEMPORARY CESSATION OF THE EARTH DISTURBANCE ACTIVITY IN A SPECIAL PROTECTION WATERSHED, THAT PORTION OF THE PROJECT SITE TRIBUTARY TO THE SPECIAL PROTECTION WATERSHEDS MUST BE IMMEDIATELY STABILIZED.
38. IF COAL OR OTHER ACID-PRODUCING ROCK IS ENCOUNTERED AT THE PROJECT SITE, THE ACID PRODUCING ROCK WILL EITHER BE REMOVED FROM THE SITE OR HANDLED ON-SITE. IF COAL OR OTHER ACID-PRODUCING ROCK MUST BE HANDLED ON SITE IS SHOULD BE SAMPLED AND ANALYZED FOR TOTAL PERCENT SULFUR IN ACCORDANCE WITH PADEPS GUIDANCE. ON-SITE HANDLING METHODS SHOULD BE BASED ON TESTING AND PADEP GUIDANCE.
39. IF A SINKHOLE IS ENCOUNTERED, REPAIR SHOULD BE DONE UNDER THE DIRECT OBSERVATION AND SUPERVISION OF A PROFESSIONAL GEOLOGIST OR LICENSED GEOTECHNICAL ENGINEER. SITE SPECIFIC SINKHOLE REPAIRS SHOULD BE DEVELOPED ON A CASE BY CASE BASIS.
40. IN-STREAM WORK TO OCCUR IN MINOR WATER BODIES (>10 FEET WIDE) WITHIN 24 HOURS, AND IN MAJOR WATER BODIES (10 TO 100 FEET WIDE) WITHIN 48 HOURS UNLESS APPROVED IN WRITING BY THE DEPARTMENT.

CONSTRUCTION SEQUENCE:

REFER TO THE E&S PLAN DRAWINGS FOR THE LOCATION OF THE PROPOSED WORK AND THE ASSOCIATED BMPs. A GENERALIZED CONSTRUCTION SEQUENCE IS PROVIDED BELOW. THE CONSTRUCTION SEQUENCE IS INTENDED TO PROVIDE A GENERAL COURSE OF ACTION IN ORDER TO CONFORM TO THE APPLICABLE REGULATORY AGENCY REQUIREMENTS FOR TEMPORARY AND PERMANENT SOIL EROSION AND SEDIMENTATION CONTROLS. NECESSARY PARTS FOR PROPER AND COMPLETE EXECUTION OF WORK PERTAINING TO THIS PLAN, WHETHER SPECIFICALLY MENTIONED OR NOT, ARE TO BE PERFORMED BY THE CONTRACTOR. IT IS NOT INTENDED THAT THE DRAWINGS AND THIS REPORT SHOW DETAILED INFORMATION ON METHODS AND MATERIALS. THE CONTRACTOR SHALL COMPLY WITH ALL REQUIREMENTS LISTED IN THIS SECTION. THE CONTRACTOR MAY BE REQUIRED TO ALTER CONTROLS BASED ON EFFECTIVENESS OF CONTROLS OR DIFFERING CONDITIONS ENCOUNTERED IN THE FIELD.

1. MAKE ALL APPROPRIATE NOTIFICATIONS AS INDICATED IN GENERAL NOTES ON PLAN SHEET ES-0.01.
2. FLAG OR FENCE PROJECT LIMITS OF DISTURBANCE AND APPROVED ACCESS. SIGN AND FLAG WETLAND BOUNDARIES AND STREAMS.

3. ORANGE CONSTRUCTION FENCE WILL BE PROVIDED AND INSTALLED AT WETLAND AREAS ADJACENT TO THE LOD AND NOT PLANNED TO BE IMPACTED TO IDENTIFY AND DETER CONSTRUCTION EQUIPMENT, VEHICLES AND PERSONNEL FROM ENTERING WETLAND.
4. LOCATE STAGING AREAS AND ACCESS POINTS INCLUDING CONSTRUCTION ENTRANCES. INSTALL COMPOST FILTER SOCKS DOWN SLOPE OF THESE AREAS.
5. INSTALL ROCK CONSTRUCTION ENTRANCES AS NEEDED. REFER TO THE ROCK CONSTRUCTION ENTRANCE DETAIL ON PLAN SHEET ES-0.06.
6. CONSTRUCT THE PROPOSED ACCESS ROADS AND IMPLEMENT TEMPORARY IMPROVEMENTS AS IDENTIFIED IN ACCESS ROAD SUMMARY TABLE AND DETAILED ON THE PLAN SHEETS.
7. INSTALL COMPOST FILTER SOCKS AS SHOWN ON THE CONSTRUCTION DRAWINGS. INSTALLATIONS SIZING, AND SPACING MUST CONFORM TO THE CHART AND DETAILS PROVIDED ON PLAN SHEET ES-0.06. APPROPRIATELY SIZED SILT FENCE IS AN APPROVED ALTERNATIVE IN AREAS THAT ARE NOT SPECIAL PROTECTION WATERSHEDS AND MUST CONFORM TO THE CHART AND DETAILS PROVIDED ON PLAN SHEET ES-0.07.
8. CLEARING, GRUBBING, AND TOPSOIL STRIPPING SHALL COMMENCE ALONG THE PIPELINE ROUTE AND BE LIMITED TO THOSE AREAS DESCRIBED IN EACH STAGE OF THE CONSTRUCTION SEQUENCE. GENERAL SITE CLEARING, GRUBBING AND TOPSOIL STRIPPING MAY NOT COMMENCE IN ANY STAGE OR PHASE OF THE PROJECT UNTIL THE E&S BMPs SPECIFIED BY THE BMP SEQUENCE FOR THAT STAGE OR PHASE HAVE BEEN INSTALLED AND ARE FUNCTIONING AS DESCRIBED IN THIS E&S PLAN. FOR CLEARING, GRUBBING, AND TOPSOIL REMOVAL IN ALL STREAM, RIVER, WETLAND OR OTHER WATER BODY CROSSINGS, REFER TO CONSTRUCTION SEQUENCE NOTES BELOW. TOPSOIL WILL BE SEGREGATED AT LOCATIONS THROUGHOUT THE PROJECT WHERE TOPSOIL EXISTS.
9. TEMPORARY WATERBARS OR APPROVED INTERCEPTOR DYKES WILL BE INSTALLED ALONG THE ALIGNMENT PRIOR TO PIPE INSTALLATION AT THE END OF EACH WORK DAY. DURING THE PERIODS OF TIME WHERE PIPE TRENCH IS OPEN CONTRACTORS WILL PROVIDE POSITIVE CONTROL OF ALL STORM WATER ON SITE, TEMPORARY WATERBARS WILL BE CONSTRUCTED BY THE END OF THE WORK DAY, OR DURING EACH WORK DAY IF REQUIRED CONTRACTOR WILL INSTALL SILT FENCE TO CONTROL EROSION UNTIL 70% VEGETATION GROWTH HAS BEEN ACHIEVED.
10. MINIMIZE TOTAL AREA OF DISTURBANCE. MAINTAIN TEMPORARY SOIL STOCKPILES WITHIN EXISTING SOIL EROSION AND SEDIMENT CONTROLS. SHOULD EXCAVATION ENTER STREAMS, FOLLOW SPECIFIC DETAILS FOR THESE AREAS SHOWN ON THE DRAWINGS AND INCLUDE THE STEPS DETAILED IN THE SPECIFIC SECTIONS BELOW. PULLBACK AREAS FOR HDDs WILL BE CLEARED AND PREPARED AS NEEDED TO SUPPORT STAGING, WELDING AND TESTING OF THE HDD PIPE SECTIONS. AREAS NOT UTILIZED FOR CONSTRUCTION ACTIVITIES SHOULD BE AVOIDED TO MINIMIZE IMPACTS.
11. INSTALL PIPE AND TRENCH PLUGS IN ACCORDANCE WITH DETAILS ON PLAN SHEET ES-0.08. WHEN OPEN CUTTING DRIVEWAYS AND ACCESS ROADS, CONTRACTOR SHALL HAVE ROAD PLATES AVAILABLE TO MAINTAIN ACCESS FOR LANDOWNERS. THE 20-INCH PIPELINE WILL BE INSTALLED FIRST, FOLLOWED BY THE 16-INCH LINE. ANY TEMPORARY STABILIZATION REQUIRED BETWEEN THE TWO INSTALLATIONS WILL BE IMPLEMENTED IN ACCORDANCE WITH THIS E&S PLAN. BOTH PIPELINES WILL BE INSTALLED WITHIN THE SAME LIMIT OF DISTURBANCE AND IN THE SAME CONSTRUCTION PERIOD.
12. FOR OPEN-CUT AREAS, THE LENGTH OF TIME REQUIRED TO CLEAR AND GRADE THE AREA, EXCAVATE THE TRENCH, INSTALL THE PIPELINES, BACKFILL THE TRENCH AND BEGIN STABILIZATION OF DISTURBED AREAS WILL NOT EXCEED 30 CALENDAR DAYS FOR MOST INSTALLATIONS. LONGER TIME PERIODS MAY BE APPROVED ON A CASE-BY-CASE BASIS.
13. BACKFILL EXCAVATED AREA AND COVER WITH TOPSOIL (WHERE TOPSOIL WAS SEGREGATED).
14. BEFORE RESTORATION OF GRADE, THE SECOND 16-INCH PIPELINE WILL BE INSTALLED. ALL TEMPORARY BMPs WILL BE IMPLEMENTED BETWEEN THE TWO INSTALLATIONS IN ACCORDANCE WITH THE NOTES AND DETAILS FOR TEMPORARY SEEDING AND COVER.
15. RESTORE GRADE TO ORIGINAL SURFACE ELEVATIONS AS SOON AS PRACTICABLE FOLLOWING COMPLETION OF INSTALLATION OF PIPES. INSTALL PERMANENT WATERBARS IN ACCORDANCE WITH PLAN SHEET ES-0.08. IMMEDIATELY SEED AND MULCH DISTURBED AREAS OR PREPARE FOR PAVING IN ROADWAY AREAS.
16. INSTALL EROSION CONTROL BLANKET ON ALL SLOPES 3:1 OR GREATER AND ALL AREAS, REGARDLESS OF SLOPE AND WITHIN 100 FEET OF SPECIAL PROTECTION WATERSHEDS OR 50 FEET OF NON-SPECIAL PROTECTION SURFACE WATERSHEDS. LOCATIONS ARE SHOWN ON PLAN SHEETS.
17. IN AREAS THAT USED STONE OR TIMBER MATS FOR TEMPORARY STABILIZATION AND/OR ACCESS, THE STONE OR MATS WILL BE REMOVED AND, IF NEEDED, THE SOIL WILL BE SCARIFIED OR RIPPED TO A DEPTH OF 8-12 INCHES TO DE-COMPACT THE SOIL. AFTER RE-ESTABLISHING PRE-CONSTRUCTION CONDITIONS, TOPSOIL WILL BE REPLACED TO A MINIMUM DEPTH OF 4-8 INCHES AND SEEDED AND MULCHED. VEHICULAR TRAFFIC AFTER RESTORATION SHOULD BE RESTRICTED FROM AREAS TO PREVENT SOIL COMPACTION.
18. MAINTAIN EROSION AND SEDIMENTATION CONTROL DEVICES UNTIL SITE WORK IS COMPLETE AND A UNIFORM 70% PERENNIAL VEGETATIVE COVER IS ESTABLISHED. REMOVE SOIL AND EROSION SEDIMENT CONTROL MEASURES UPON ESTABLISHMENT OF A UNIFORM 70% PERENNIAL VEGETATIVE COVER OVER THE DISTURBED AREA. RE-GRADE AND REVEGETATE AREAS DISTURBED DURING THE REMOVAL OF THE SOIL EROSION AND SEDIMENT CONTROLS.
19. AS PART OF THE ONGOING STORM WATER BMP INSPECTION AND MAINTENANCE PROGRAM ANY STRUCTURAL BMP RECORDED ON THIS PROJECT WILL BE INSPECTED MAINTAINED, AND REPAIRED IN ACCORDANCE WITH THE PLAN FILED WITH THE DEED.
20. IN ACCORDANCE WITH 25 PA CODE 102.7, UPON COMPLETION OF ALL CONSTRUCTION ACTIVITIES, A NOTICE OF TERMINATION FORM WILL BE SUBMITTED TO TERMINATE THE AUTHORIZATION OF COVERAGE INDICATING ALL ACTIVITIES UNDER THIS PERMIT HAVE BEEN COMPLETED.
21. FOR ALL EV WETLAND AND STREAM CROSSINGS, SPLP WILL INSTALL THE SECOND PIPELINE IMMEDIATELY FOLLOWING THE INSTALLATION OF THE FIRST PIPELINE, AS LONG AS NO UNANTICIPATED, EXTRANEOUS CIRCUMSTANCES OR SAFETY ISSUES ARE ENCOUNTERED. THE TWO PIPES WILL BE INSTALLED IN A SINGLE DISTURBANCE THAT WILL NOT REQUIRE INTERIM TEMPORARY STABILIZATION/RESTORATION.

FOR STREAM, RIVER, WETLANDS OR OTHER WATER BODY UTILITY CROSSINGS THAT WILL BE OPEN CUT:

1. NO WORK SHALL COMMENCE THROUGH A STREAM, RIVER, WETLANDS OR OTHER WATER BODY DURING INCLEMENT WEATHER.
2. A UTILITY LINE CROSSING OF A STREAM CHANNEL 10 FEET IN BOTTOM WIDTH OR LESS SHALL BE COMPLETED WITHIN 24 HOURS FROM START TO FINISH INCLUDING TRENCH BACKFILL, STABILIZATION OF STREAM BANKS AND STABILIZATION OF THE AREA 50 FEET BACK FROM THE TOP OF EACH STREAM BANK.
3. A UTILITY LINE CROSSING OF A STREAM CHANNEL BETWEEN 10 FEET AND 100 FEET IN BOTTOM WIDTH SHALL BE COMPLETED WITHIN 48 HOURS FROM START TO FINISH INCLUDING TRENCH BACKFILL, STABILIZATION OF STREAM BANKS AND STABILIZATION OF THE AREA 50 FEET BACK FROM THE TOP OF EACH STREAM BANK.
4. WETLAND CROSSINGS ARE TO BE COMPLETED ALONG WITH THE MAINLINE INSTALLATION AND WILL BE DEPENDENT UPON THE LENGTH OF THE CROSSING.
5. FACILITIES FOR REMOVING SEDIMENT FROM PUMPED WATER SHOULD BE AVAILABLE AT THE STREAM CROSSING SITE BEFORE TRENCHING COMMENCES AND MAINTAINED UNTIL TRENCH BACKFILLING IS COMPLETED. ASSEMBLY AREAS, TEMPORARY EQUIPMENT AND NON-HAZARDOUS MATERIAL STORAGE AREAS SHALL BE LOCATED AT LEAST 50 FEET BACK FROM THE TOP OF ANY BANK.
6. INSTALL TEMPORARY EQUIPMENT CROSSINGS AT STREAMS AND TEMPORARY TIMBER MATS AT WETLAND CROSSINGS IN ACCORDANCE WITH NOTES AND DETAILS.
7. FOR DRY STREAM CROSSINGS INSTALL PUMP BYPASS, DRY FLUME, OR COFFERDAM IN ACCORDANCE WITH NOTES AND DETAILS.
8. DEWATERING WORK AREA. WATER FROM THE EXCAVATION SHALL BE PUMPED TO A SEDIMENT FILTER BAG. WHERE POSSIBLE, EXCAVATION SHALL BE FROM THE TOP OF THE STREAM BANK, WHERE TECHNICALLY FEASIBLE.
9. STABILIZE CHANNEL EXCAVATION AND STREAM BANKS PRIOR TO REDIRECTING STREAM FLOW.

FOR CONVENTIONAL AND HDD BORE CROSSINGS:

CONVENTIONAL BORES

1. CONVENTIONAL BORES WILL BE CONDUCTED ALONG WITH MAIN LINE INSTALLATION TO LIMIT THE TIME OF DISTURBANCE IN THOSE AREAS.
2. INSTALL COMPOST FILTER SOCKS DOWNGRADIENT OF THE BORE AND RECEIVING PITS.
3. EXCAVATE PITS AS SHOWN IN THE TYPICAL STREAM CROSSING DETAIL ON PLAN SHEET ES-0.17
4. BORE BENEATH STREAMS WHERE INDICATED ON THE CONSTRUCTION DRAWINGS.
5. WATER FROM THE BORE PITS AND WORK AREAS SHALL BE PUMPED TO A PUMPED WATER FILTER BAG IN ACCORDANCE WITH DETAIL ON PLAN SHEET ES-0.08.
6. UPON COMPLETION, BACKFILL ALL PITS.

HDD BORES

1. INSTALL COMPOST FILTER SOCKS AT STAGING AND PULLBACK AREAS IN ACCORDANCE WITH E&S PLAN SHEETS. WHERE APPLICABLE TEMPORARY GRADING OF STAGING AREAS IS PROVIDED ON PLAN SHEETS.
2. BORE AND PULLBACK AREAS SHALL BE LOCATED A MINIMUM OF 50 FEET BACK FROM EACH TOP OF STREAM BANK UNLESS AUTHORIZED BY PADEP.
3. THE HDD BORE ALIGNMENT SHALL BE MONITORED FOR INADVERTENT RETURNS. AN INADVERTENT RETURN PLAN HAS BEEN DEVELOPED FOR THIS PROJECT. THIS PLAN IS TO BE REVIEWED, ONSITE, AND IMPLEMENTED FOR EACH DRILL CONDUCTED.
4. UPON COMPLETION OF HDD BORE, RESTORE BORE AND PULLBACK AREAS TO PRE-CONSTRUCTION CONDITIONS IN ACCORDANCE WITH E&S PLANS AND DETAILS.

FOR WORKING WITHIN A WETLAND AREA:

1. LOCATE STAGING AREAS AND ACCESS POINTS. STAGING AREAS SHOULD BE LOCATED AT LEAST 50 FEET FROM THE EDGE OF THE WETLAND. INSTALL SEDIMENT BARRIERS DOWN SLOPE OF THESE AREAS.
2. INSTALL ROCK CONSTRUCTION ENTRANCE AS NEEDED. REFER TO THE ROCK CONSTRUCTION ENTRANCE DETAIL ON DRAWINGS FOR SUGGESTED DIMENSIONS.
3. INSTALL ORANGE FLAGGING AROUND PERIMETER OF WETLAND AND SEDIMENT BARRIERS ALONG THE PERIMETERS OF THE SITE AS SHOWN ON THE CONSTRUCTION DRAWINGS.
4. MATS, PADS, OR SIMILAR DEVICES SHALL BE USED DURING THE CROSSINGS OF WETLANDS. ORIGINAL GRADES THROUGH WETLANDS MUST BE RESTORED AFTER TRENCHING AND BACKFILLING. ANY EXCESS FILL MATERIALS MUST BE REMOVED FROM THE WETLAND AND NOT SPREAD ON-SITE.
5. SOIL EXCAVATED FROM WETLAND AREAS SHALL BE CAREFULLY REMOVED WITH THE ROOTS INTACT. THIS SOIL SHOULD BE PLACED IN A SEPARATE STOCKPILE TO BE REUSED DURING THE WETLAND SURFACE RESTITUTION.
6. DEWATER WORK AREA; WATER FROM THE EXCAVATION SHALL BE PUMPED TO A SEDIMENT TRAP OR A FILTER BAG.
7. INSTALL PIPE.
8. INSTALL TRENCH PLUGS IN WETLAND AREAS TO PREVENT THE TRENCH FROM DRAINING THE WETLAND OR CHANGING ITS HYDROLOGY.
9. BACKFILL PIPE TRENCH. BACKFILL THE TOP 12-INCHES OF THE EXCAVATED TRENCH WITH THE STOCKPILED WETLAND SOIL TO MATCH ORIGINAL SURFACE GRADES.
10. NO SOIL AMENDMENTS SUCH AS AGRICULTURAL LIME, FERTILIZER, ETC. WILL BE USED WITHIN WETLAND AREAS.
11. COMPACT BACKFILL AND GRADE THE SURFACE OF THE TRENCH AREA TO ALLOW FOR POSITIVE DRAINAGE TO SOIL EROSION AND SEDIMENT CONTROLS AND TO PREPARE DISTURBED AREAS FOR PERMANENT TRENCH RESTORATION.
12. MAINTAIN ALL EROSION AND SEDIMENTATION CONTROL DEVICES UNTIL SITE WORK IS COMPLETE AND A UNIFORM 70% PERENNIAL VEGETATIVE COVER IS ESTABLISHED.
13. REMOVE ALL SOIL AND EROSION SEDIMENT CONTROL MEASURES UPON ESTABLISHMENT OF A UNIFORM 70% VEGETATIVE COVER OVER THE DISTURBED AREA. RE-GRADE AND REVEGETATE AREAS DISTURBED DURING THE REMOVAL OF THE SOIL EROSION AND SEDIMENT CONTROLS.

FOR TEMPORARY EQUIPMENT STREAM AND WETLAND CROSSINGS:

1. INSTALL TEMPORARY EQUIPMENT CROSSINGS AND TEMPORARY TIMBER MAT WETLAND CROSSINGS IN ACCORDANCE WITH PLAN SHEETS ES-0.18.
2. TEMPORARY STREAM CROSSINGS SHALL BE INSPECTED ON A DAILY BASIS. DAMAGED CROSSINGS SHALL BE REPAIRED WITHIN 24 HOURS OF THE INSPECTION AND BEFORE ANY SUBSEQUENT USE. SEDIMENT DEPOSITS ON THE CROSSING OR ITS APPROACHES SHALL BE REMOVED WITHIN 24 HOURS OF THE INSPECTION.
3. AS SOON AS THE TEMPORARY CROSSING IS NO LONGER NEEDED, REMOVE TEMPORARY CROSSING. ALL MATERIALS SHALL BE DISPOSED OF PROPERLY AND DISTURBED AREAS STABILIZED. REMOVE ALL SOIL AND EROSION SEDIMENT CONTROL MEASURES UPON ESTABLISHMENT OF A UNIFORM 70% VEGETATIVE COVER OVER THE DISTURBED AREA.

TEMPORARY EROSION AND SEDIMENT CONTROLS INSPECTION AND MAINTENANCE SCHEDULE		
BMP	INSPECTION FREQUENCY	MAINTENANCE TO BE PERFORMED
COMPOST FILTER SOCK	WEEKLY AND AFTER RUNOFF EVENTS	MAINTENANCE SHALL BE PERFORMED AS NEEDED. SEDIMENT SHALL BE REMOVED ONCE IT HAS ACCUMULATED TO ONE HALF THE ORIGINAL HEIGHT OF THE BARRIER. COMPOST FILTER SOCK SHALL BE REPLACED WHENEVER IT HAS DETERIORATED TO SUCH AN EXTENT THAT THE EFFECTIVENESS OF COMPOST FILTER SOCK IS REDUCED. COMPOST FILTER SOCKS SHALL REMAIN IN PLACE UNTIL DISTURBED AREAS HAVE BEEN PERMANENTLY STABILIZED. ALL SEDIMENT ACCUMULATION AT THE COMPOST FILTER SOCK SHALL BE REMOVED AND PROPERLY DISPOSED OF BEFORE THE COMPOST FILTER SOCK IS REMOVED.
ROCK CONSTRUCTION ENTRANCE	DAILY	CONTRACTOR SHALL MAINTAIN/REPLACE MATERIAL AS NEEDED THROUGHOUT CONSTRUCTION TO MAINTAIN EFFECTIVENESS AND SPECIFIED MINIMUM THICKNESS DURING USE OF ACCESS ROAD. A STOCKPILE OF ROCK WILL BE MAINTAINED ON SITE FOR THIS PURPOSE
MULCH STABILIZATION	WEEKLY AND AFTER RUNOFF EVENTS	REPLACE MULCH AS REQUIRED. RESTORE SEEDING IN AFFECTED AREA IF NECESSARY.
TIMBER MAT	WEEKLY AND AFTER RUNOFF EVENTS	INSPECT THE TIMBER MAT FOR EROSION AND MAKE ANY NECESSARY REPAIRS.
WATERBARS	WEEKLY AND AFTER RUNOFF EVENTS	WATERBARS SHALL BE INSPECTED WEEKLY (DAILY ON ACTIVE ROADS) AND AFTER EACH RUNOFF EVENT. DAMAGED OR ERODED WATERBARS SHALL BE RESTORED TO ORIGINAL DIMENSIONS WITHIN 24 HOURS OF INSPECTION.
PUMPED WATER FILTER BAGS	DAILY	FILTER BAGS SHALL BE REPLACED WHEN THEY BECOME 1/2 FULL OF SEDIMENT. IF ANY PROBLEM IS DETECTED, PUMPING SHALL CEASE IMMEDIATELY AND NOT RESUME UNTIL THE PROBLEM IS CORRECTED.

STANDARD EROSION AND SEDIMENT CONTROL PLAN NOTES:

1. ALL EARTH DISTURBANCES, INCLUDING CLEARING AND GRUBBING, CUTS, FILLS, TRENCHING, AND TEMPORARY ROAD CONSTRUCTION OR IMPROVEMENT, SHALL BE DONE IN ACCORDANCE WITH AN APPROVED E&S PLAN. A COPY OF THE APPROVED DRAWINGS (STAMPED, SIGNED AND DATED BY THE REVIEWING AGENCY) MUST BE AVAILABLE AT THE PROJECT SITE AT ALL TIMES. THE REVIEWING AGENCY SHALL BE NOTIFIED OF ANY CHANGES TO THE APPROVED PLAN PRIOR TO IMPLEMENTATION OF THOSE CHANGES. THE REVIEWING AGENCY MAY REQUIRE A WRITTEN SUBMITTAL OF THOSE CHANGES FOR REVIEW AND APPROVAL AT ITS DISCRETION.
2. AT LEAST 7 DAYS PRIOR TO STARTING ANY EARTH DISTURBANCE ACTIVITIES, INCLUDING CLEARING AND GRUBBING, THE OWNER AND/OR OPERATOR SHALL INVITE ALL CONTRACTORS, THE LANDOWNER, APPROPRIATE MUNICIPAL OFFICIALS, THE E&S PLAN PREPARER, THE PCSM PLAN PREPARER, THE LICENSED PROFESSIONAL RESPONSIBLE FOR OVERSIGHT OF CRITICAL STAGES OF IMPLEMENTATION OF THE PCSM PLAN, AND A REPRESENTATIVE FROM THE LOCAL CONSERVATION DISTRICT TO AN ON-SITE PRECONSTRUCTION MEETING.
3. AT LEAST 3 DAYS PRIOR TO STARTING ANY EARTH DISTURBANCE ACTIVITIES, OR EXPANDING INTO AN AREA PREVIOUSLY UNMARKED, THE PENNSYLVANIA ONE CALL SYSTEM INC. SHALL BE NOTIFIED AT 1-800-242-1776 FOR THE LOCATION OF EXISTING UNDERGROUND UTILITIES.
4. ALL EARTH DISTURBANCE ACTIVITIES SHALL PROCEED IN ACCORDANCE WITH THE SEQUENCE PROVIDED ON THE PLAN DRAWINGS. DEVIATION FROM THAT SEQUENCE MUST BE APPROVED IN WRITING FROM THE LOCAL CONSERVATION DISTRICT OR BY THE DEPARTMENT PRIOR TO IMPLEMENTATION.
5. AREAS TO BE FILLED ARE TO BE CLEARED, GRUBBED, AND STRIPPED OF TOPSOIL TO REMOVE TREES, VEGETATION, ROOTS AND OTHER OBJECTIONABLE MATERIAL.
6. CLEARING, GRUBBING, AND TOPSOIL STRIPPING SHALL BE LIMITED TO THOSE AREAS DESCRIBED IN EACH STAGE OF THE CONSTRUCTION SEQUENCE. GENERAL SITE CLEARING, GRUBBING AND TOPSOIL STRIPPING MAY NOT COMMENCE IN ANY STAGE OR PHASE OF THE PROJECT UNTIL THE E&S BMPs SPECIFIED BY THE BMP SEQUENCE FOR THAT STAGE OR PHASE HAVE BEEN INSTALLED AND ARE FUNCTIONING AS DESCRIBED IN THIS E&S PLAN.
7. AT NO TIME SHALL CONSTRUCTION VEHICLES BE ALLOWED TO ENTER AREAS OUTSIDE THE LIMIT OF DISTURBANCE BOUNDARIES SHOWN ON THE PLAN MAPS. THESE AREAS MUST BE CLEARLY MARKED AND/OR FENCED OFF BEFORE CLEARING AND GRUBBING OPERATIONS BEGIN.
8. TOPSOIL REQUIRED FOR THE ESTABLISHMENT OF VEGETATION SHALL BE STOCKPILED AT THE LOCATION(S) SHOWN ON THE PLAN MAPS(S) IN THE AMOUNT NECESSARY TO COMPLETE THE FINISH GRADING OF ALL EXPOSED AREAS THAT ARE TO BE STABILIZED BY VEGETATION. EACH STOCKPILE SHALL BE PROTECTED IN THE MANNER SHOWN ON THE PLAN DRAWINGS. STOCKPILE HEIGHTS SHALL NOT EXCEED 35 FEET. STOCKPILE SLOPES SHALL BE 2H:1V OR FLATTER. SEGREGATION OF TOPSOIL SHALL OCCUR WHERE TOPSOIL EXISTS WITHIN THE WORK AREA.
9. IMMEDIATELY UPON DISCOVERING UNFORESEEN CIRCUMSTANCES POSING THE POTENTIAL FOR ACCELERATED EROSION AND/OR SEDIMENT POLLUTION, THE OPERATOR SHALL IMPLEMENT APPROPRIATE BEST MANAGEMENT PRACTICES TO MINIMIZE THE POTENTIAL FOR EROSION AND SEDIMENT POLLUTION AND NOTIFY THE LOCAL CONSERVATION DISTRICT AND/OR THE REGIONAL OFFICE OF THE DEPARTMENT.
10. ALL BUILDING MATERIALS AND WASTES SHALL BE REMOVED FROM THE SITE AND RECYCLED OR DISPOSED OF IN ACCORDANCE WITH THE DEPARTMENT'S SOLID WASTE MANAGEMENT REGULATIONS AT 25 PA. CODE 260.1 ET SEQ., 271.1, AND 287.1 ET. SEQ. NO BUILDING MATERIALS OR WASTES OR UNUSED BUILDING MATERIALS SHALL BE BURNED, BURIED, DUMPED, OR DISCHARGED AT THE SITE.
11. ALL OFF-SITE WASTE AND BORROW AREAS MUST HAVE AN E&S PLAN APPROVED BY THE LOCAL CONSERVATION DISTRICT OR THE DEPARTMENT FULLY IMPLEMENTED PRIOR TO BEING ACTIVATED.
12. THE CONTRACTOR IS RESPONSIBLE FOR ENSURING THAT ANY MATERIAL BROUGHT ON SITE IS CLEAN FILL. FORM FP-001 MUST BE RETAINED BY THE PROPERTY OWNER FOR ANY FILL MATERIAL AFFECTED BY A SPILL OR RELEASE OF A REGULATED SUBSTANCE BUT QUALIFYING AS CLEAN FILL DUE TO ANALYTICAL TESTING.
13. ALL PUMPING OF WATER FROM ANY WORK AREA SHALL BE DONE ACCORDING TO THE PROCEDURE DESCRIBED IN THIS PLAN, OVER UNDISTURBED VEGETATED AREAS.



661 ANDERSEN DRIVE - FOSTER PLAZA 7
PITTSBURGH, PA 15220
T: (412) 921-7090 | F: (412) 921-4040

REVISIONS			
NO.	BY	DATE	REMARKS



SUNOCO PIPELINE L.P.
SINKING SPRING, PENNSYLVANIA
**PENNSYLVANIA PIPELINE PROJECT
CONSTRUCTION SPREAD 3**

1-16" & 1-20" PROPOSED WELDED STEEL NATURAL GAS LIQUIDS PIPELINES
HUNTINGDON COUNTY CONSERVATION DISTRICT
**EROSION & SEDIMENT CONTROL &
SITE RESTORATION PLAN
NOTES & DETAILS**

DATE:	NOVEMBER 2016
PROJECT NO.:	1121C05958
DESIGNED BY:	JB
DRAWN BY:	BH
CHECKED BY:	RS
COPYRIGHT TETRA TECH INC.	
ES-0.04	
SHEET 0.04 OF 111	

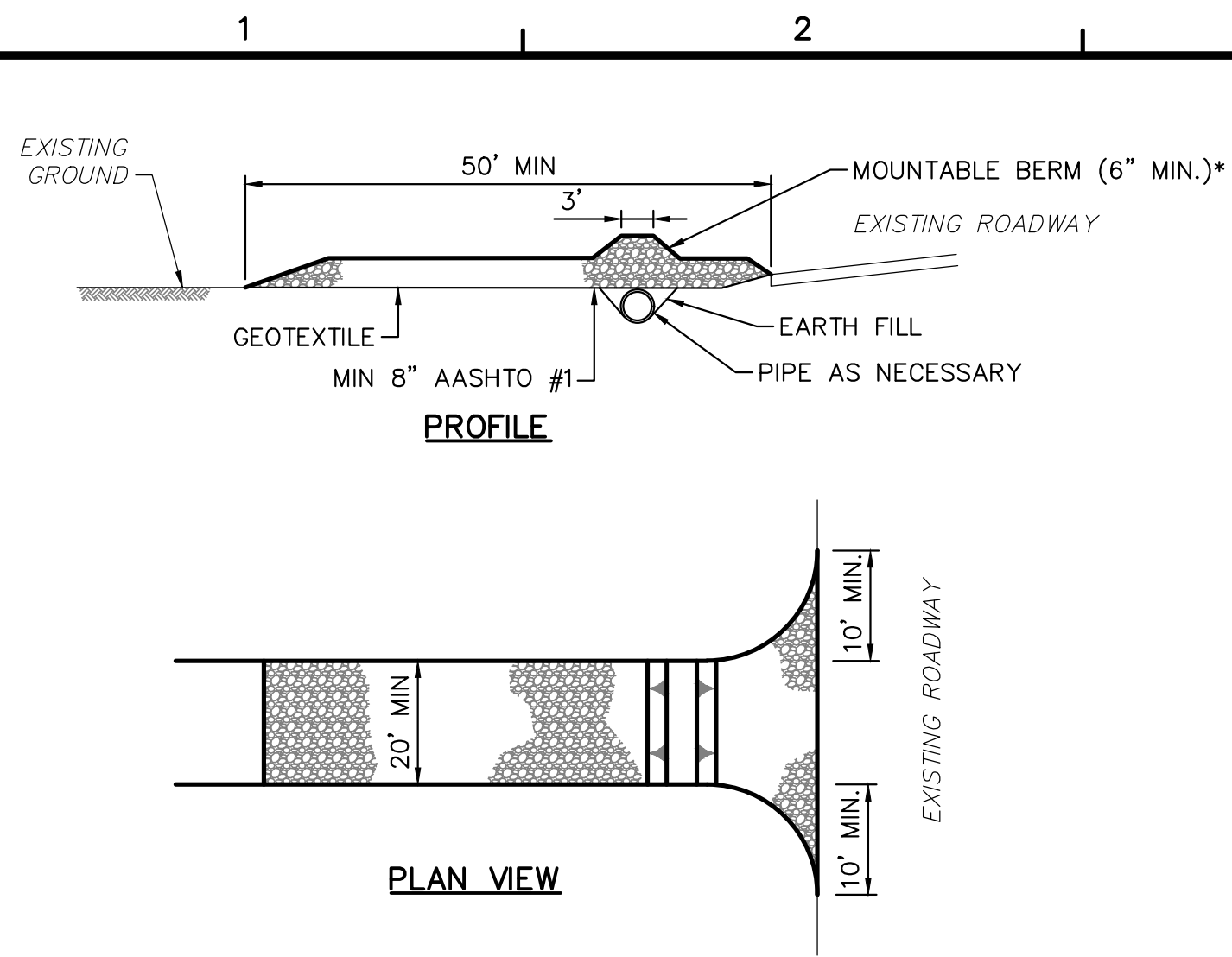

* MOUNTABLE BERM USED TO PROVIDE PROPER COVER FOR PIPE IF NEEDED.

NOTES:
 REMOVE TOPSOIL PRIOR TO INSTALLATION OF ROCK CONSTRUCTION ENTRANCE. EXTEND ROCK OVER FULL WIDTH OF ENTRANCE.
 RUNOFF SHALL BE DIVERTED FROM ROADWAY TO A SUITABLE SEDIMENT REMOVAL BMP PRIOR TO ENTERING ROCK CONSTRUCTION ENTRANCE.
 MOUNTABLE BERM SHALL BE INSTALLED WHEREVER OPTION CULVERT PIPE IS USED AND PROPER PIPE COVER AS SPECIFIED BY MANUFACTURER IS NOT OTHERWISE PROVIDED. PIPE SHALL BE SIZED APPROPRIATELY FOR SIZE OF DITCH BEING CROSSED.
 MAINTENANCE: ROCK CONSTRUCTION ENTRANCE THICKNESS SHALL BE CONSTANTLY MAINTAINED TO THE SPECIFIED DIMENSIONS BY ADDING ROCK. A STOCKPILE SHALL BE MAINTAINED ON SITE FOR THE PURPOSE. ALL SEDIMENT DEPOSITED ON PAVED ROADWAYS SHALL BE REMOVED AND RETURNED TO THE CONSTRUCTION SITE IMMEDIATELY. IF EXCESSIVE AMOUNTS OF SEDIMENT ARE BEING DEPOSITED ON ROADWAY, EXTEND LENGTH OF ROCK CONSTRUCTION ENTRANCE BY 50 FOOT INCREMENTS UNTIL CONDITION IS ALLEVIATED OR INSTALL WASH RACK. WASHING THE ROADWAY OR SWEEPING THE DEPOSITS INTO ROADWAY DITCHES, SEWERS, CULVERTS, OR OTHER DRAINAGE COURSES IS NOT ACCEPTABLE.

ROCK CONSTRUCTION ENTRANCE 1
NOT TO SCALE 0.06

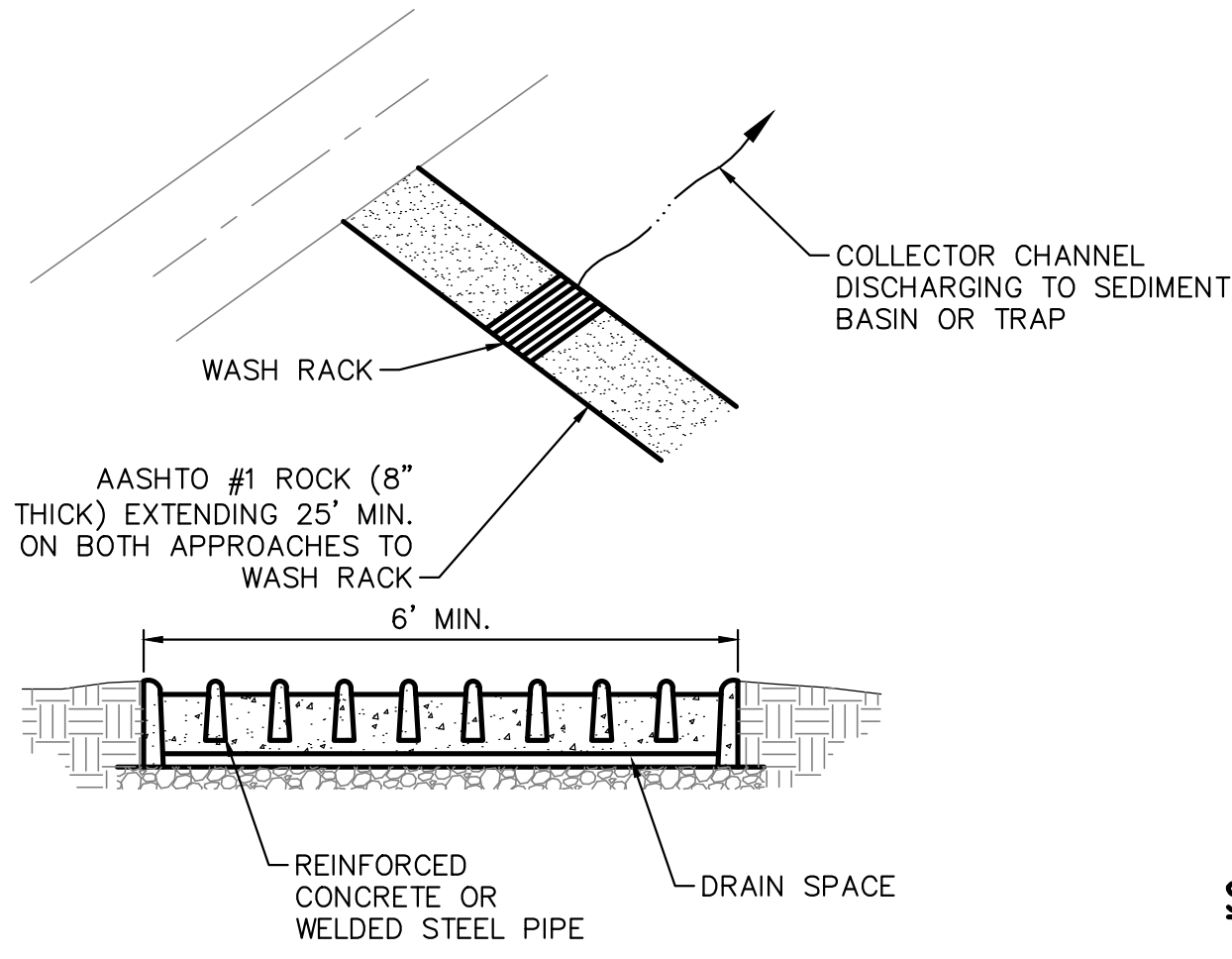

NOTES:
 WASH RACK SHALL BE 20 FEET (MIN.) WIDE OR TOTAL WIDTH OF ACCESS.
 WASH RACK SHALL BE DESIGNED AND CONSTRUCTED TO ACCOMMODATE ANTICIPATED CONSTRUCTION VEHICULAR TRAFFIC.
 A WATER SUPPLY SHALL BE MADE AVAILABLE TO WASH THE WHEELS OF ALL VEHICLES EXITING THE SITE.
 MAINTENANCE: ROCK CONSTRUCTION ENTRANCE THICKNESS SHALL BE CONSTANTLY MAINTAINED TO THE SPECIFIED DIMENSIONS BY ADDING ROCK. A STOCKPILE OF ROCK MATERIAL SHALL BE MAINTAINED ON SITE FOR THIS PURPOSE. DRAIN SPACE UNDER WASH RACK SHALL BE KEPT OPEN AT ALL TIMES. DAMAGE TO THE WASH RACK SHALL BE REPAIRED PRIOR TO FURTHER USE OF THE RACK. ALL SEDIMENT DEPOSITED ON ROADWAYS SHALL BE REMOVED AND RETURNED TO THE CONSTRUCTION SITE IMMEDIATELY. WASHING THE ROADWAY OR SWEEPING THE DEPOSITS INTO ROADWAY DITCHES, SEWERS, CULVERTS, OR OTHER DRAINAGE COURSES IS NOT ACCEPTABLE.

ROCK CONSTRUCTION ENTRANCE WITH WASH RACK 3
NOT TO SCALE 0.06

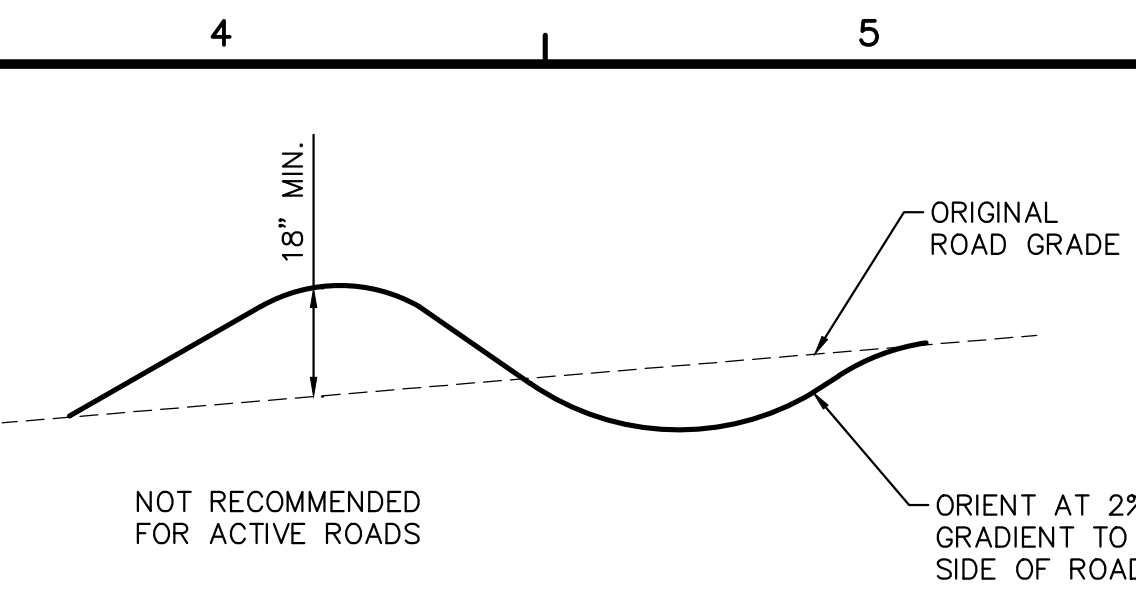
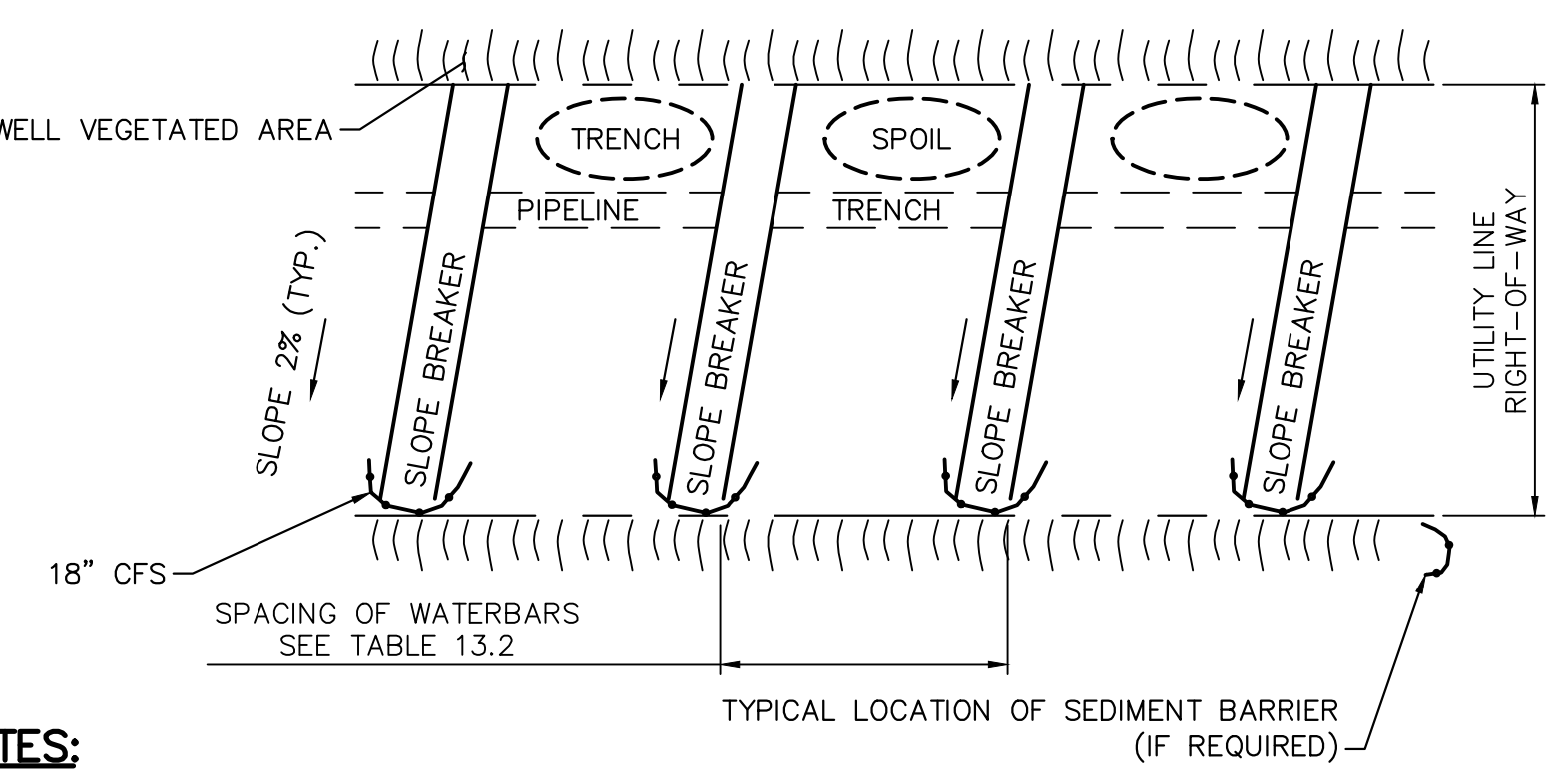

TABLE 13.2
MAXIMUM SPACING FOR PERMANENT WATERBARS ON A UTILITY LINE RIGHT-OF-WAY

PERCENT SLOPE	SPACING (FT)
<5	250
5-15	150
15-30	100
>30	50



NOTES:
 WATERBARS SHALL DISCHARGE TO A STABLE AREA.
 WATERBARS SHALL BE INSPECTED WEEKLY (DAILY ON ACTIVE ROADS) AND AFTER EACH RUNOFF EVENT. DAMAGED OR ERODED WATERBARS SHALL BE RESTORED TO ORIGINAL DIMENSIONS WITHIN 24 HOURS OF INSPECTION.
 MAINTENANCE OF WATERBARS SHALL BE PROVIDED UNTIL ROADWAY, SKIDTRAIL, OR RIGHT-OF-WAY HAS ACHIEVED PERMANENT STABILIZATION.
 WATERBARS ON RETIRED ROADWAYS, SKIDTRAILS, AND RIGHT-OF-WAYS SHALL BE LEFT IN PLACE AFTER PERMANENT STABILIZATION HAS BEEN ACHIEVED.
 SEE TABLE 13.2 ABOVE FOR WATERBAR SPACING.
 PERMANENT WATERBARS ARE REQUIRED AT ALL STREAM, RIVER, AND OTHER WATER-BODY CROSSINGS AS WELL AS UPSLOPE FROM ROADWAY AND RAILROAD CUT SLOPES.

WATERBAR 2
NOT TO SCALE 0.06

MAXIMUM SLOPE LENGTHS FOR COMPOST FILTER SOCK

% SLOPE	12" DIAMETER	18" DIAMETER	24" DIAMETER
2 (OR LESS)	520	700	1000
5	250	340	500
10	150	250	300
15	100	200	250
20	70	140	200
25	50	100	140
30	45	70	100
35	40	60	90
40	35	45	60
45	30	40	50
50	20	30	40

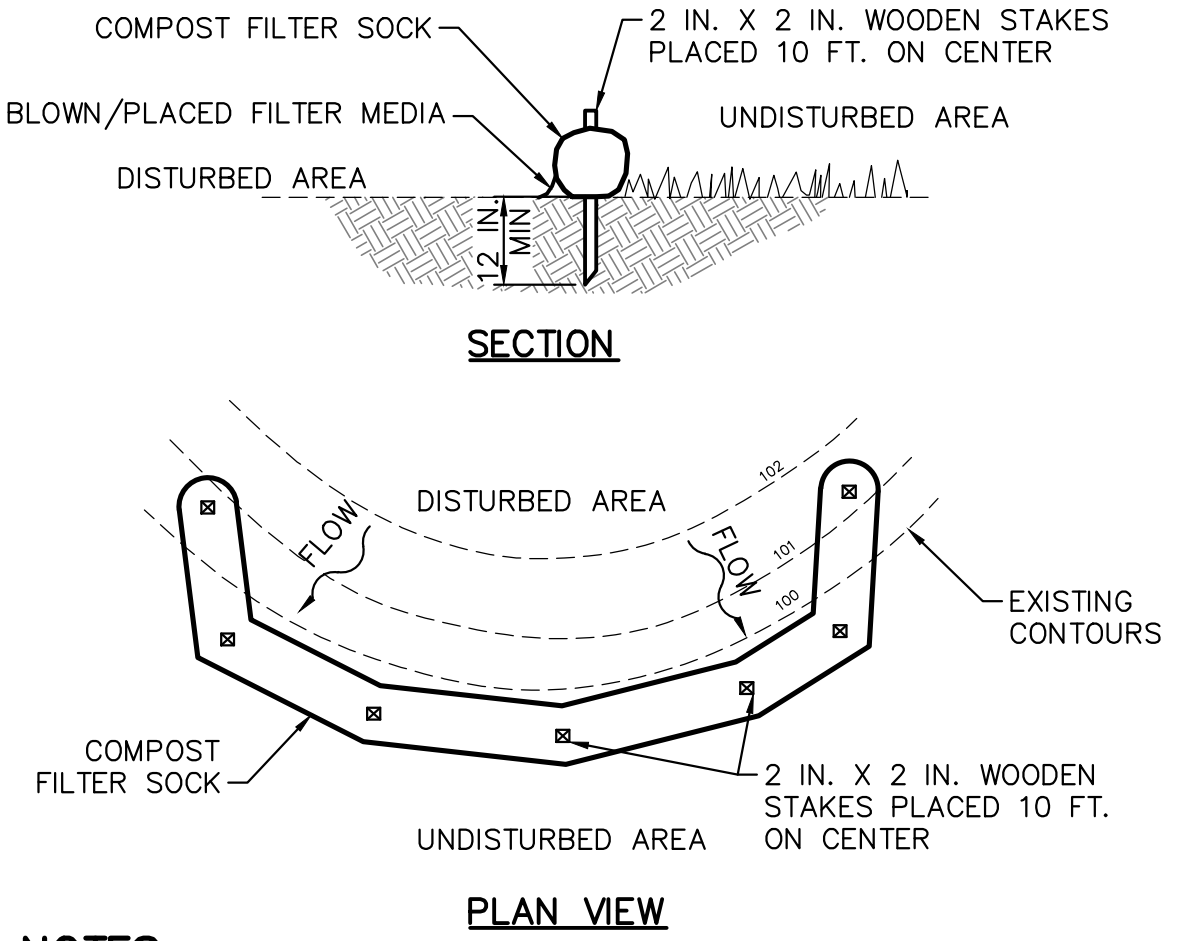

NOTES:
 SOCK FABRIC SHALL MEET STANDARDS OF TABLE 4.1 OF THE PA DEP EROSION CONTROL MANUAL. COMPOST SHALL MEET THE STANDARDS OF TABLE 4.2 OF THE EPA DEP EROSION CONTROL MANUAL.
 COMPOST FILTER SOCK SHALL BE PLACED AT EXISTING LEVEL GRADE. BOTH ENDS OF THE BARRIER SHALL BE EXTENDED AT LEAST 8 FEET UP SLOPE AT 45 DEGREES TO THE MAIN BARRIER ALIGNMENT. MAXIMUM SLOPE LENGTH ABOVE ANY BARRIER SHALL NOT EXCEED THAT SPECIFIED FOR THE SIZE OF THE SOCK AND THE SLOPE OF ITS TRIBUTARY AREA.
 TRAFFIC SHALL NOT BE PERMITTED TO CROSS COMPOST FILTER SOCKS.
 ACCUMULATED SEDIMENT SHALL BE REMOVED WHEN IT REACHES 1/2 THE ABOVE GROUND HEIGHT OF THE BARRIER AND DISPOSED IN THE MANNER DESCRIBED ELSEWHERE IN THE PLAN.
 COMPOST FILTER SOCK SHALL BE INSPECTED WEEKLY AND AFTER EACH RUNOFF EVENT. DAMAGED SOCKS SHALL BE REPAIRED ACCORDING TO MANUFACTURER'S SPECIFICATIONS OR REPLACED WITHIN 24 HOURS OF INSPECTION.
 BIODEGRADABLE COMPOST FILTER SOCKS SHALL BE REPLACED AFTER 6 MONTHS; PHOTODEGRADABLE SOCKS AFTER 1 YEAR. POLYPROPYLENE SOCKS SHALL BE REPLACED ACCORDING TO MANUFACTURER'S RECOMMENDATIONS.
 UPON STABILIZATION OF THE AREA TRIBUTARY TO THE SOCK, STAKES SHALL BE REMOVED. THE SOCK MAY BE LEFT IN PLACE AND VEGETATED OR REMOVED. IN THE LATTER CASE, THE MESH SHALL BE CUT OPEN AND THE MULCH SPREAD AS A SOIL SUPPLEMENT.

TABLE 4.1

COMPOST SOCK FABRIC MINIMUM SPECIFICATIONS

MATERIAL TYPE	3 MIL HDPE	5 MIL HDPE	5 MIL HDPE	MULTI-FILAMENT POLYPROPYLENE (MFPP)	HEAVY DUTY MULTI-FILAMENT POLYPROPYLENE (HDMFPP)
MATERIAL CHARACTERISTICS	PHOTO-DEGRADABLE	PHOTO-DEGRADABLE	BIO-DEGRADABLE	PHOTO-DEGRADABLE	PHOTO-DEGRADABLE
SOCK DIAMETERS	12" 18"	12" 18" 24" 32"	12" 18" 24" 32"	12" 18" 24" 32"	12" 18" 24" 32"
MESH OPENING	3/8"	3/8"	3/8"	3/8"	1/8"
TENSILE STRENGTH		26 PSI	26 PSI	44 PSI	202 PSI
ULTRAVIOLET STABILITY % ORIGINAL STRENGTH (ASTM G-155)	23% AT 1000 HR.	23% AT 1000 HR.		100% AT 1000 HR.	100% AT 1000 HR.
MINIMUM FUNCTIONAL LONGEVITY	6 MONTHS	9 MONTHS	6 MONTHS	1 YEAR	2 YEARS

TWO-PLY SYSTEMS

INNER CONTAINMENT NETTING	HDPE BIAXIAL NET CONTINUOUSLY WOUND
	FUSION-WELDED JUNCTURES
OUTER FILTRATION MESH	3/4" X 3/4" MAX. APERTURE SIZE COMPOSITE POLYPROPYLENE FABRIC (WOVEN LAYER AND NON-WOVEN FLEECE MECHANICALLY FUSED VIA NEEDLE PUNCH)
	3/16" MAX. APERTURE SIZE

SOCK FABRICS COMPOSED OF BURLAP MAY BE USED ON PROJECTS LASTING 6 MONTHS OR LESS.

TABLE 4.2

COMPOST STANDARDS

ORGANIC MATTER CONTENT	25%-100% (DRY WEIGHT BASIS)
ORGANIC PORTION	FIBROUS AND ELONGATED
PH	5.5-8.5
MOISTURE CONTENT	30%-60%
PARTICLE SIZE	30%-50% PASS THROUGH 3/8" SIEVE
SOLUBLE SALT CONCENTRATION	5.0 DS/M (MMHOS/XM) MAXIMUM

SLOPE INSTALLATION:

- PREPARE SOIL BEFORE INSTALLING RECPs, INCLUDING ANY NECESSARY APPLICATION OF LIME, FERTILIZER AND SEED.
- BEGIN AT THE TOP OF THE SLOPE BY ANCHORING THE RECPs IN A 6 IN. DEEP X 6 IN. WIDE TRENCH WITH APPROXIMATELY 12 IN. OF RECPs EXTENDED BEYOND THE UPSLOPE PORTION OF THE TRENCH. ANCHOR THE RECPs WITH A ROW OF STAPLES/STAKES APPROXIMATELY 12 IN. APART IN THE BOTTOM OF THE TRENCH. BACKFILL AND COMPACT THE TRENCH AFTER STAPLING. APPLY SEED TO THE COMPACTED SOIL AND FOLD THE REMAINING 12 IN. PORTION OF RECPs BACK OVER THE SEED AND COMPACTED SOIL. SECURE RECPs OVER COMPACTED SOIL WITH A ROW OF STAPLES/STAKES SPACED APPROXIMATELY 12 IN. APART ACROSS THE WIDTH OF THE RECPs.
- ROLL THE RECPs (3A) DOWN OR (3B) HORIZONTALLY ACROSS THE SLOPE. RECPs WILL UNROLL WITH APPROPRIATE SIDE AGAINST THE SOIL SURFACE. ALL RECPs MUST BE SECURELY FASTENED TO SOIL SURFACE BY REPLACING STAPLES/STAKES IN APPROPRIATE LOCATIONS AS SHOWN IN THE STAPLE PATTERN GUIDE.
- THE EDGES OF PARALLEL RECPs MUST BE STAPLED WITH AN APPROXIMATELY 2 IN. - 5 IN. OVERLAP DEPENDING ON THE RECP TYPE.
- CONSECUTIVE RECP SPliced DOWN THE SLOPE MUST BE END-OVER-END (SHINGLE STYLE) WITH AN APPROXIMATE 3 IN. OVERLAP. STAPLE THROUGH OVERLAPPED AREA, APPROXIMATELY 12 IN. APART ACROSS ENTIRE RECPs WIDTH.

STAPLE PATTERN GUIDE

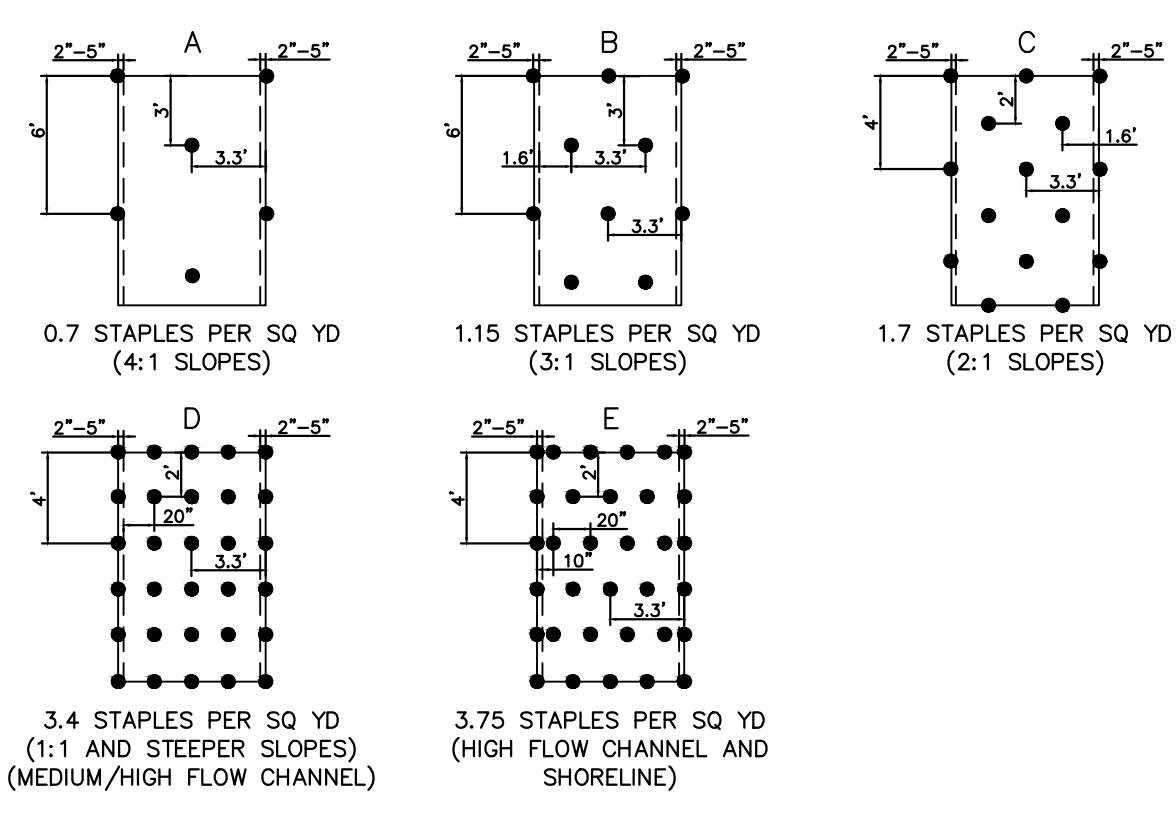

- NOTES:**
- FOR SLOPES BETWEEN 3:1 AND 1:1, USE NORTH AMERICAN GREEN ERONET SC 150 OR OWNER APPROVED EQUAL MATERIAL/METHOD.
 - IN AREAS WHERE LIVESTOCK ARE KEPT, USE NORTH AMERICAN GREEN BIONET SC 150 BN OR OWNER APPROVED EQUAL MATERIAL/METHOD.
 - SEED AND SOIL AMENDMENTS SHALL BE APPLIED ACCORDING TO THE RATES IN THE PLAN DRAWINGS PRIOR TO INSTALLING THE BLANKET.
 - PROVIDE ANCHOR TRENCH AT TOE OF SLOPE IN SIMILAR FASHION AS AT TOP OF SLOPE
 - SLOPE SURFACE SHALL BE FREE OF ROCKS, CLOUDS, STICKS, AND GRASS.
 - BLANKET SHALL HAVE GOOD CONTINUOUS CONTACT WITH UNDERLYING SOIL THROUGHOUT ENTIRE PROJECT LENGTH. LAY BLANKET LOOSELY AND STAKE OR STAPLE TO MAINTAIN DIRECT CONTACT WITH SOIL. DO NOT STRETCH BLANKET.
 - THE BLANKET SHALL BE STAPLED IN ACCORDANCE WITH THE MANUFACTURERS RECOMMENDATIONS.
 - BLANKETED AREAS SHALL BE INSPECTED WEEKLY AND AFTER EACH RUNOFF EVENT UNTIL PERENNIAL VEGETATION IS ESTABLISHED TO A MINIMUM UNIFORM 70% COVERAGE THROUGHOUT THE BLANKETED AREA. DAMAGED OR DISPLACED BLANKETS SHALL BE RESTORED OR REPLACED WITHIN 4 CALENDAR DAYS.

EROSION CONTROL BLANKET - SLOPE INSTALLATION 4
NOT TO SCALE 0.06

COMPOST FILTER SOCK 5
NOT TO SCALE 0.06

TETRA TECH
 www.tetrattech.com
 661 ANDERSEN DRIVE - FOSTER PLAZA 7
 PITTSBURGH, PA 15220
 T: (412) 921-7090 | F: (412) 921-4040

REVISIONS

NO.	BY	DATE	REMARKS

COMMONWEALTH OF PENNSYLVANIA
 REGISTERED PROFESSIONAL ENGINEER
 ROBERT F. SIMCIC
 ENGINEER IN CHARGE

SUNOCO PIPELINE L.P.
 SINKING SPRING, PENNSYLVANIA
PENNSYLVANIA PIPELINE PROJECT
CONSTRUCTION SPREAD 3

1-16" & 1-20" PROPOSED WELDED STEEL NATURAL GAS LIQUIDS PIPELINES
 HUNTINGDON COUNTY CONSERVATION DISTRICT
EROSION & SEDIMENT CONTROL & SITE RESTORATION PLAN
NOTES & DETAILS

DATE: NOVEMBER 2016
 PROJECT NO.: 1121C05958
 DESIGNED BY: JB
 DRAWN BY: BH
 CHECKED BY: RS
 COPYRIGHT TETRA TECH INC.
ES-0.06
 SHEET 0.06 OF 111

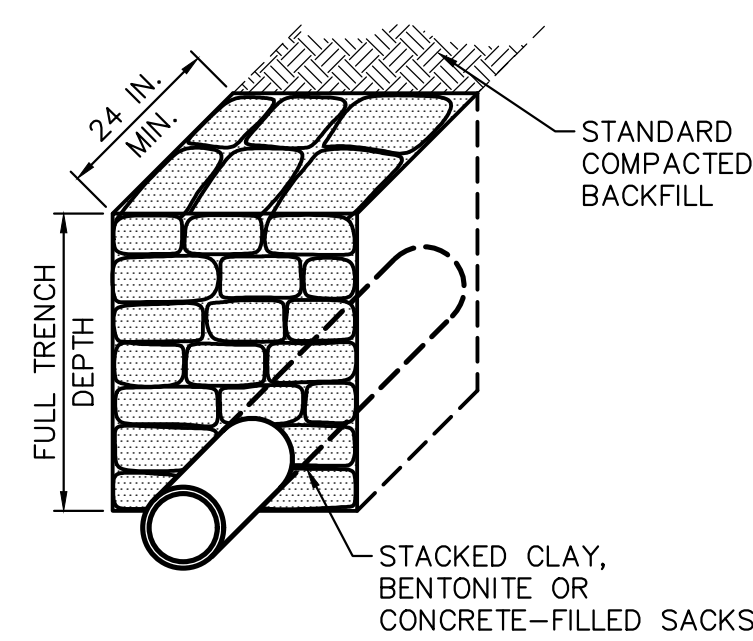

SECTION VIEW

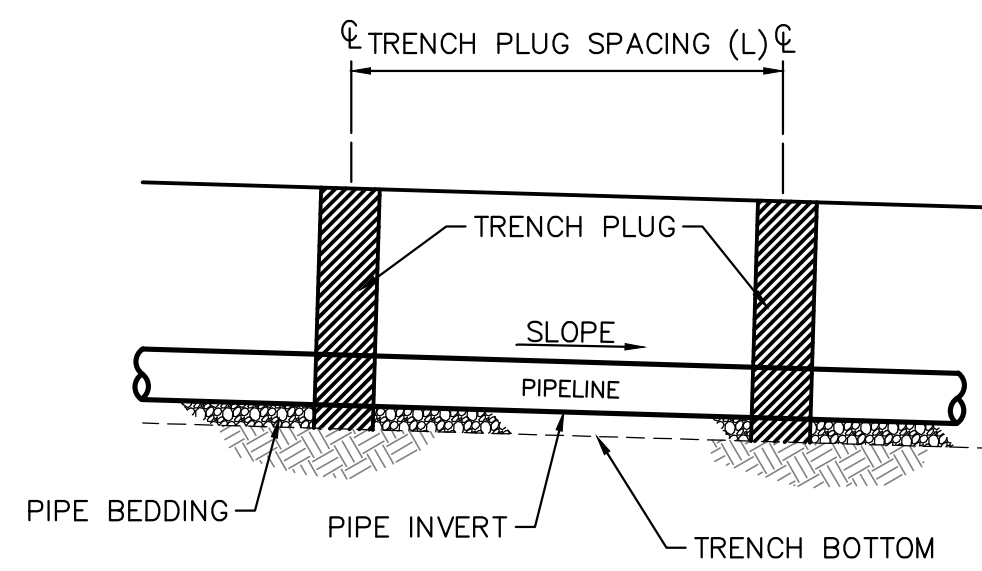

ELEVATION

TRENCH SLOPE (%)	SPACING L (FT)	PLUG MATERIAL
<5	1,000	* CLAY, BENTONITE OR CONCRETE-FILLED SACKS
5-15	500	* CLAY, BENTONITE OR CONCRETE-FILLED SACKS
15-25	300	* CLAY, BENTONITE OR CONCRETE-FILLED SACKS
25-35	200	* CLAY, BENTONITE OR CONCRETE-FILLED SACKS
35-100	100	* CLAY, BENTONITE OR CONCRETE-FILLED SACKS
>100	50	CEMENT BAGS (WETTED) OR MORTARED STONE

* TOP SOIL MAY NOT BE USED TO FILL SACKS

NOTES:

IMPERVIOUS TRENCH PLUGS ARE REQUIRED FOR ALL STREAM, RIVER, WETLAND, OR OTHER WATERBODY CROSSINGS.

TRENCH PLUG INSTALLATION 10
NOT TO SCALE 0.08

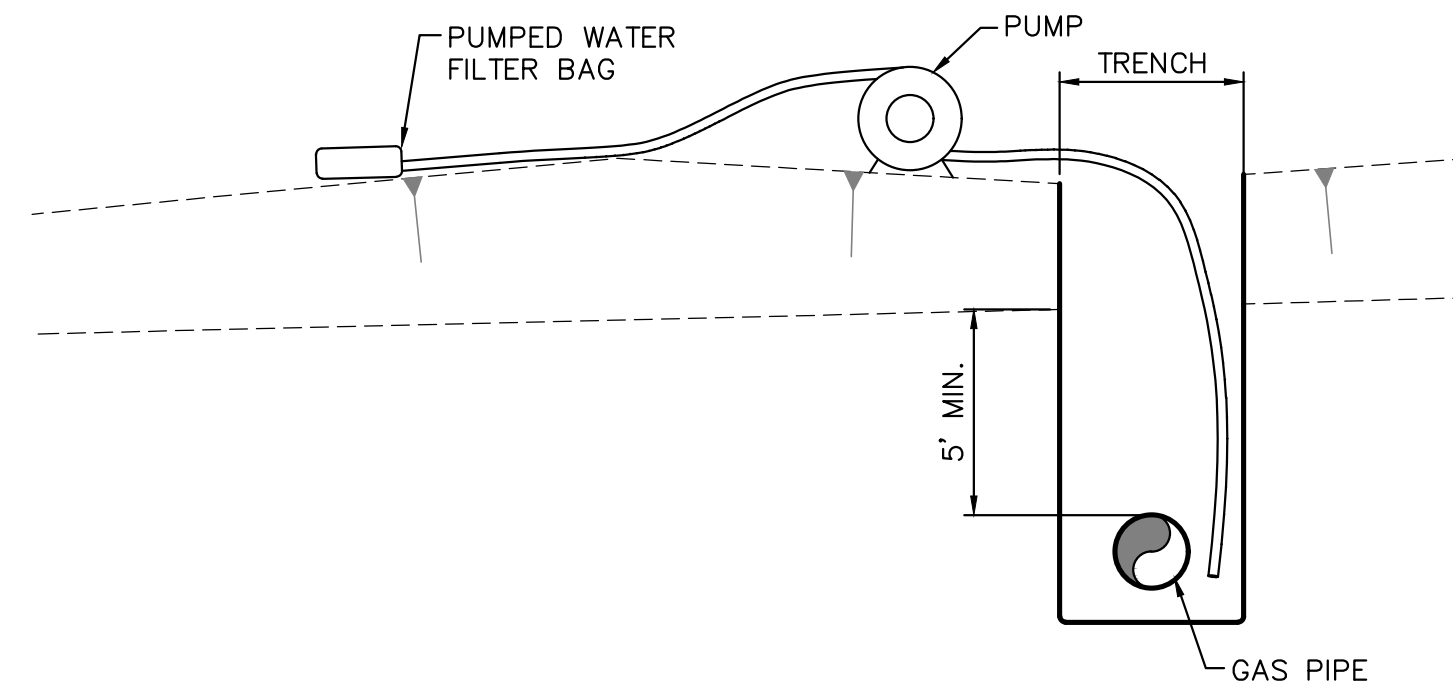

TRENCH DEWATERING DETAIL
NOT TO SCALE

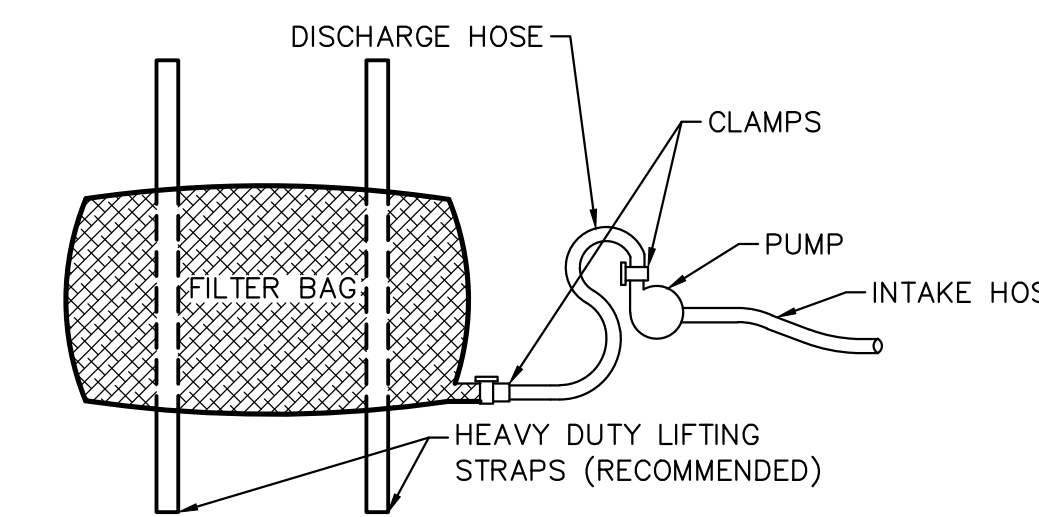

PLAN VIEW

NOTES:

LOW VOLUME FILTER BAGS SHALL BE MADE FROM NON-WOVEN GEOTEXTILE MATERIAL SEWN WITH HIGH STRENGTH, DOUBLE STITCHED "J" TYPE SEAMS. THEY SHALL BE CAPABLE OF TRAPPING PARTICLES LARGER THAN 150 MICRONS. HIGH VOLUME FILTER BAGS SHALL BE MADE FROM WOVEN GEOTEXTILES THAT MEET THE FOLLOWING STANDARDS:

PROPERTY	TEST METHOD	MINIMUM STANDARD
AVG. WIDE WIDTH STRENGTH	ASTM D-4884	60 LB/IN
GRAB TENSILE	ASTM D-4632	205 LB
PUNCTURE	ASTM D-4833	110 LB
MULLEN BURST	ASTM D-3786	350 PSI
UV RESISTANCE	ASTM D-4355	70%
AOS % RETAINED	ASTM D-3751	80 SIEVE

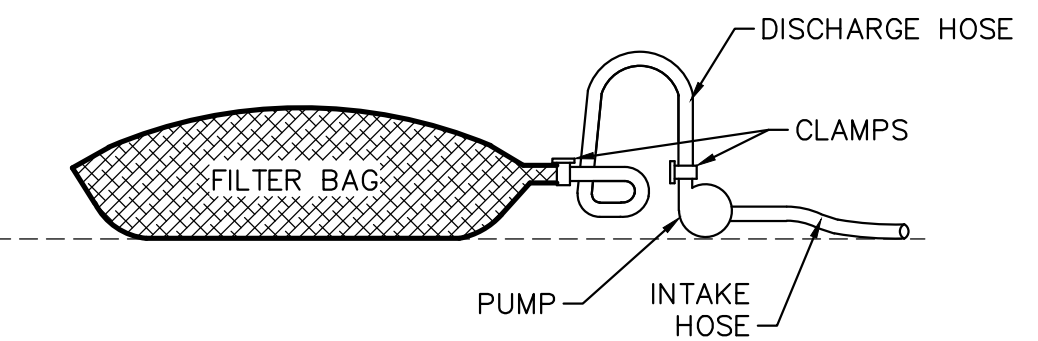

ELEVATION VIEW

A SUITABLE MEANS OF ACCESSING THE BAG WITH MACHINERY REQUIRED FOR DISPOSAL PURPOSES SHALL BE PROVIDED. FILTER BAGS SHALL BE REPLACED WHEN THEY BECOME 1/2 FULL OF SEDIMENT. SPARE BAGS SHALL BE KEPT AVAILABLE FOR REPLACEMENT OF THOSE THAT HAVE FAILED OR ARE FILLED. BAGS SHALL BE PLACED ON STRAPS TO FACILITATE REMOVAL UNLESS BAGS COME WITH LIFTING STRAPS ALREADY ATTACHED.

BAGS SHALL BE LOCATED IN WELL-VEGETATED (GRASSY) AREA, AND DISCHARGE ONTO STABLE, EROSION RESISTANT AREAS. WHERE THIS IS NO POSSIBLE, A GEOTEXTILE UNDERLAYMENT AND FLOW PATH SHALL BE PROVIDED. BAGS MAY BE PLACED ON FILTER STONE TO INCREASE DISCHARGE CAPACITY. BAGS SHALL NOT BE PLACED ON SLOPES GREATER THAN 5% FOR SLOPES EXCEEDING 5%. CLEAN ROCK OR OTHER NON-ERODIBLE AND NON-POLLUTING MATERIAL MAY BE PLACED UNDER THE BAG TO REDUCE SLOPE STEEPNESS.

NO DOWNSLOPE SEDIMENT BARRIER IS REQUIRED FOR MOST INSTALLATIONS. COMPOST BERM OR COMPOST FILTER SOCK SHALL BE INSTALLED BELOW BAGS LOCATED IN HQ OR EV WATERSHEDS, WITHIN 50 FEET OF ANY RECEIVING SURFACE WATER OR WHERE GRASSY AREA IS NOT AVAILABLE.

THE PUMP DISCHARGE HOSE SHALL BE INSERTED INTO THE BAGS IN THE MANNER SPECIFIED BY THE MANUFACTURER AND SECURELY CLAMPED. A PIECE OF PVC PIPE IS RECOMMENDED FOR THIS PURPOSE.

THE PUMPING RATE SHALL BE NO GREATER THAN 750 GPM OR 1/2 THE MAXIMUM SPECIFIED BY THE MANUFACTURER, WHICHEVER IS LESS. PUMP INTAKES SHALL BE FLOATING AND SCREENED.

FILTER BAGS SHALL BE INSPECTED DAILY. IF ANY PROBLEM IS DETECTED, PUMPING SHALL CEASE IMMEDIATELY AND NOT RESUME UNTIL THE PROBLEM IS CORRECTED.

PUMPED WATER FILTER BAG 11
NOT TO SCALE 0.08

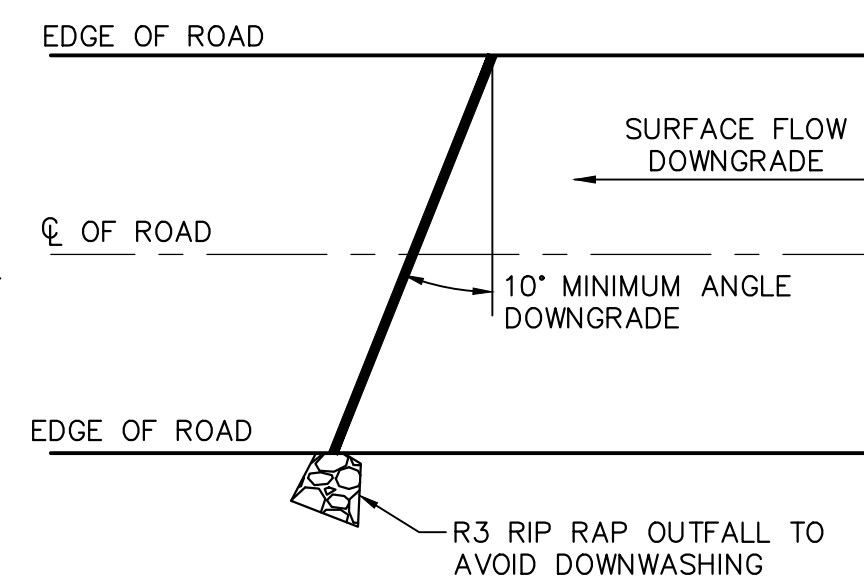
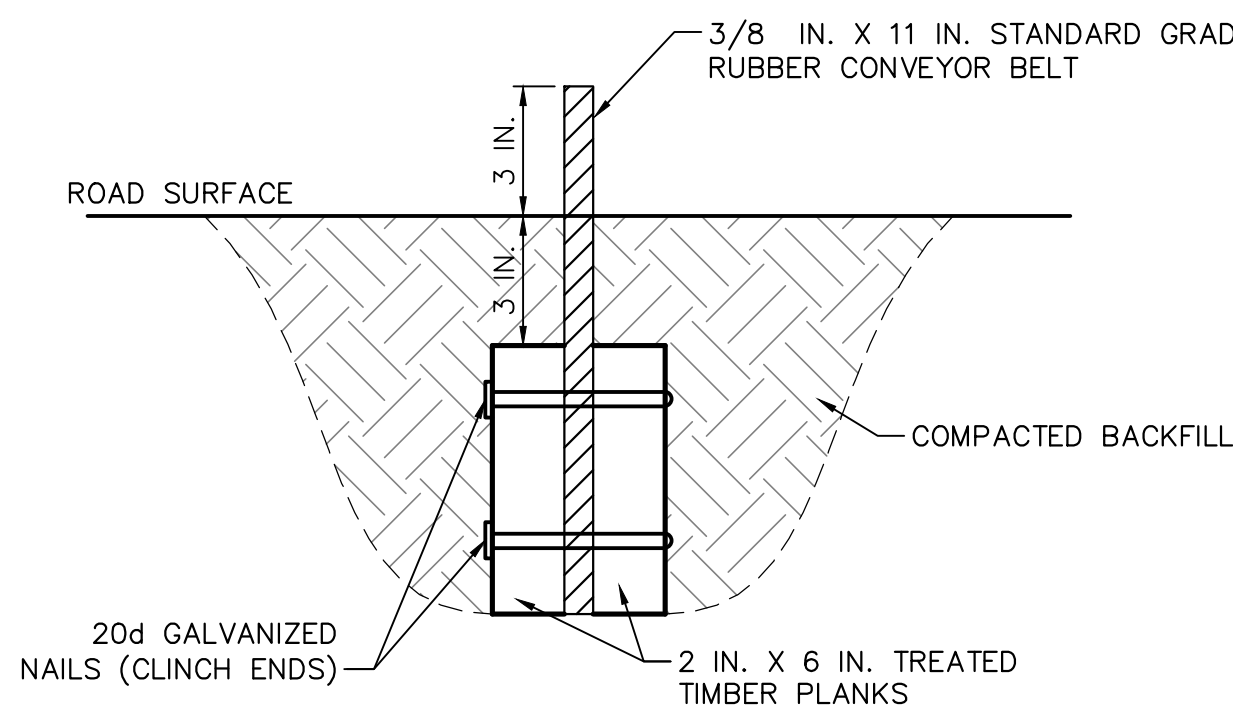

NOTE:

- DEFLECTOR SHALL BE INSPECTED WEEKLY AND AFTER EACH RUNOFF EVENT.
- ACCUMULATED SEDIMENT SHALL BE REMOVED FROM DEFLECTOR WITHIN 24 HOURS OF INSPECTION.
- BELT SHALL BE REPLACED WHEN WORN AND NO LONGER EFFECTIVE.
- MAXIMUM SPACING OF DEFLECTORS SHALL BE AS SHOWN IN TABLE.

ROAD GRADE (PERCENT)	SPACING BETWEEN DIPS, CULVERTS, OR DEFLECTORS (FEET)
<2	300
3	235
4	200
5	180
6	165
7	155
8	150
9	145
10	140

WATER DEFLECTOR 12
NOT TO SCALE 0.08

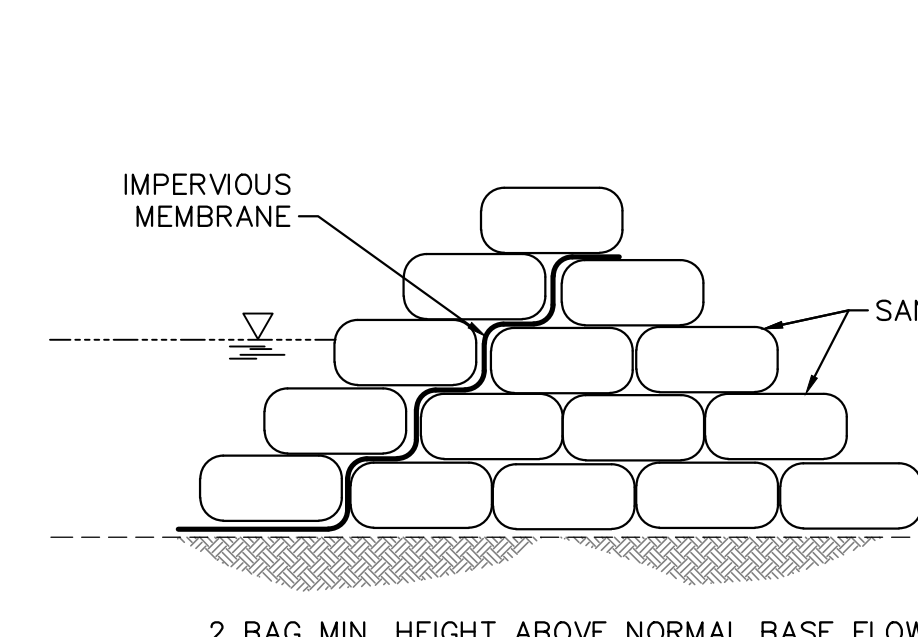

STACKED SANDBAGS OPTION

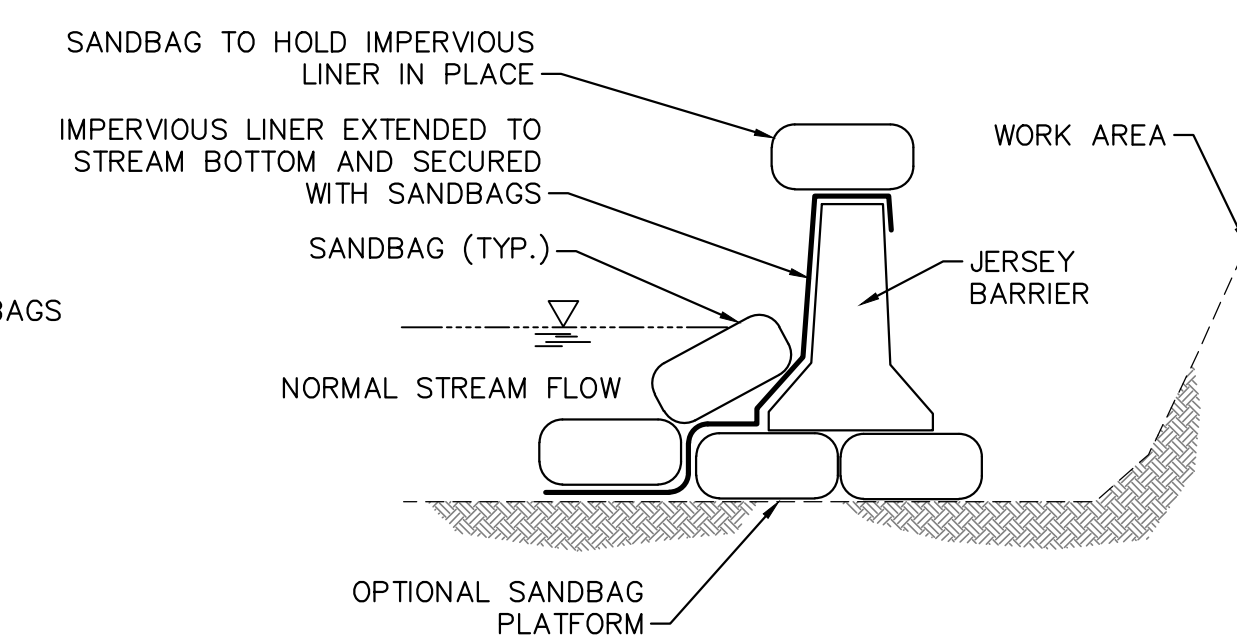

JERSEY BARRIER OPTION

NOTES:

CONSTRUCT DAMS WITH SAND BAGS, JERSEY BARRIERS OR SIMILAR MATERIAL WITH AN IMPERVIOUS LINER EXTENDED TO THE STREAM BOTTOM AND SECURED WITH SANDBAGS MAINTAINING AMBIENT DOWNSTREAM FLOW RATES.

SANDBAG OR DIVERSION DAM 13
NOT TO SCALE 0.08



www.tetrattech.com
661 ANDERSEN DRIVE - FOSTER PLAZA 7
PITTSBURGH, PA 15220
T: (412) 921-7090 | F: (412) 921-4040

REVISIONS			
NO.	BY	DATE	REMARKS

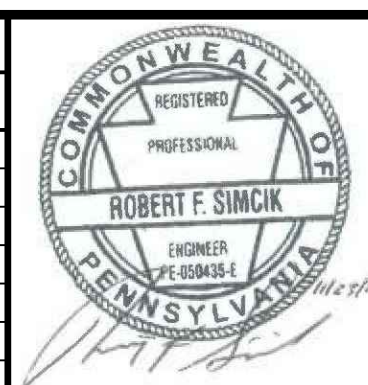

SUNOCO PIPELINE L.P.
SINKING SPRING, PENNSYLVANIA
PENNSYLVANIA PIPELINE PROJECT
CONSTRUCTION SPREAD 3

1-16" & 1-20" PROPOSED WELDED STEEL NATURAL GAS LIQUIDS PIPELINES
HUNTINGDON COUNTY CONSERVATION DISTRICT
EROSION & SEDIMENT CONTROL &
SITE RESTORATION PLAN
NOTES & DETAILS

DATE:	NOVEMBER 2016
PROJECT NO.:	112IC05958
DESIGNED BY:	JB
DRAWN BY:	BH
CHECKED BY:	RS
COPYRIGHT:	TETRA TECH INC.
ES-0.08	
SHEET 0.08 OF 111	

STREAMBANK STABILIZATION

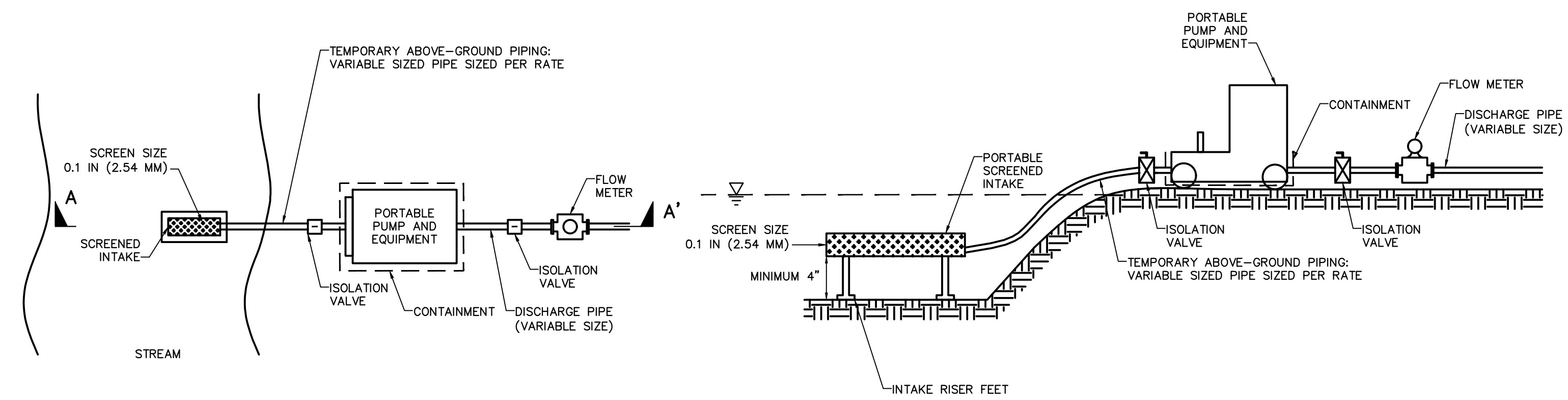

SCHEMATIC PLAN VIEW
NOT TO SCALE

INTAKE ARRANGEMENT SECTION A-A'
NOT TO SCALE

- NOTES:**
- PUMP PAD WILL MATCH EXISTING GRADE.
 - SURFACE WATER SOURCE TO BE USED FOR TEMPORARY WATER WITHDRAWALS. ALL TEMPORARY EQUIPMENT WILL BE REMOVED FROM THE FLOODWAY WHEN NOT IN USE. NO DREDGING OR FILLING ACTIVITIES CAN BE COMPLETED WITHIN THE 100-YEAR FLOODWAY WITHOUT ADDITIONAL PERMITS.

TYPICAL HYDROSTATIC TEST SUBMERGED INTAKE WITH MOBILE PUMP
NOT TO SCALE

SOUTHCENTRAL REGION												
COUNTY	STREAM	SPECIAL PROTECTION WATER	NORMAL DEPTH (ft)	SLOPE (ft/ft)	VELOCITY (ft/sec)	SHEAR STRESS (lb/sf)	SHEAR STRESS LESS THAN 0.25?	SHEAR STRESS OF NATIVE SOIL (lb/sf)	RIP RAP REQUIRED	IF "RIP RAP" REQ'D, SIZE (Table 6.6)	THICKNESS (IN) OF RIP RAP (Table 6.6)	FILTER STONE TYPE
Huntingdon	S-L52		0.68	0.068	5.3	2.89	no		yes	R-3 (1)	9	AASHTO #57
Huntingdon	S-L53		0.61	0.08	6.41	3.05	no		yes	R-4	18	AASHTO #3
Huntingdon	S-Y22		1.57	0.048	10.62	4.70	no		yes	R-5	27	AASHTO #3
Huntingdon	S-Y19-1		2.35	0.019	6.3	2.79	no		yes	R-3 (1)	9	AASHTO #57
Huntingdon	S-Y19-2		2.33	0.024	7.05	3.49	no		yes	R-4	18	AASHTO #3
Huntingdon	S-BB106	yes	1.21	0.049	8.34	3.70	no		yes	R-4	18	AASHTO #3
Huntingdon	S-L47	yes	2	0.026	7.75	3.24	no		yes	R-4	18	AASHTO #3
Huntingdon	S-L41		1.41	0.0386	7	3.40	no		yes	R-4	18	AASHTO #3
Huntingdon	S-L42	yes	0.61	0.053	4.92	2.02	no		yes	R-4	18	AASHTO #3
Huntingdon	S-M16	yes	0.29	0.023	1.78	0.42	no		yes	R-3 (1)	9	AASHTO #57
Huntingdon	S-M9	yes	0.38	0.22	6.45	5.22	no		yes	R-4	18	AASHTO #3
Huntingdon	S-M12	yes	0.98	0.101	8.1	6.18	no		yes	R-4	18	AASHTO #3
Huntingdon	S-M4	yes	0.46	0.146	7.36	4.19	no		yes	R-4	18	AASHTO #3
Huntingdon	S-M2	yes	0.5	0.28	8.74	8.74	no		yes	R-4	18	AASHTO #4
Huntingdon	S-K94	yes	3.27	0.009	7.77	1.84	no		yes	R-4	18	AASHTO #3
Huntingdon	S-L16		0.98	0.092	7.91	5.63	no		yes	R-4	18	AASHTO #3
Huntingdon	S-L13		0.22	0.03	0.18	0.41	no		yes	R-3 (1)	9	AASHTO #57
Huntingdon	S-L14		0.46	0.065	4.99	1.87	no		yes	R-3 (1)	9	AASHTO #57
Huntingdon	S-L15		0.21	0.0101	0.93	0.13	yes	0.05	yes	R-3 (1)	9	AASHTO #57
Huntingdon	S-K85		0.94	0.069	6.46	4.05	no		yes	R-4	18	AASHTO #3
Huntingdon	S-K82		2.56	0.085	10.73	13.58	no		yes	R-5	27	AASHTO #3
Huntingdon	S-K83		1.37	0.037	5.92	3.16	no		yes	R-3 (1)	9	AASHTO #57
Huntingdon	S-Y18		1.01	0.133	9.75	8.38	no		yes	R-5	27	AASHTO #3
Huntingdon	S-L24		1.09	0.082	7.58	5.58	no		yes	R-4	18	AASHTO #3

(1) R-4 IS MINIMUM RIPRAP SIZE TO BE USED. IF CALCULATIONS IDENTIFIED SMALLER STONE SIZE WILL BE INCREASED TO R-4

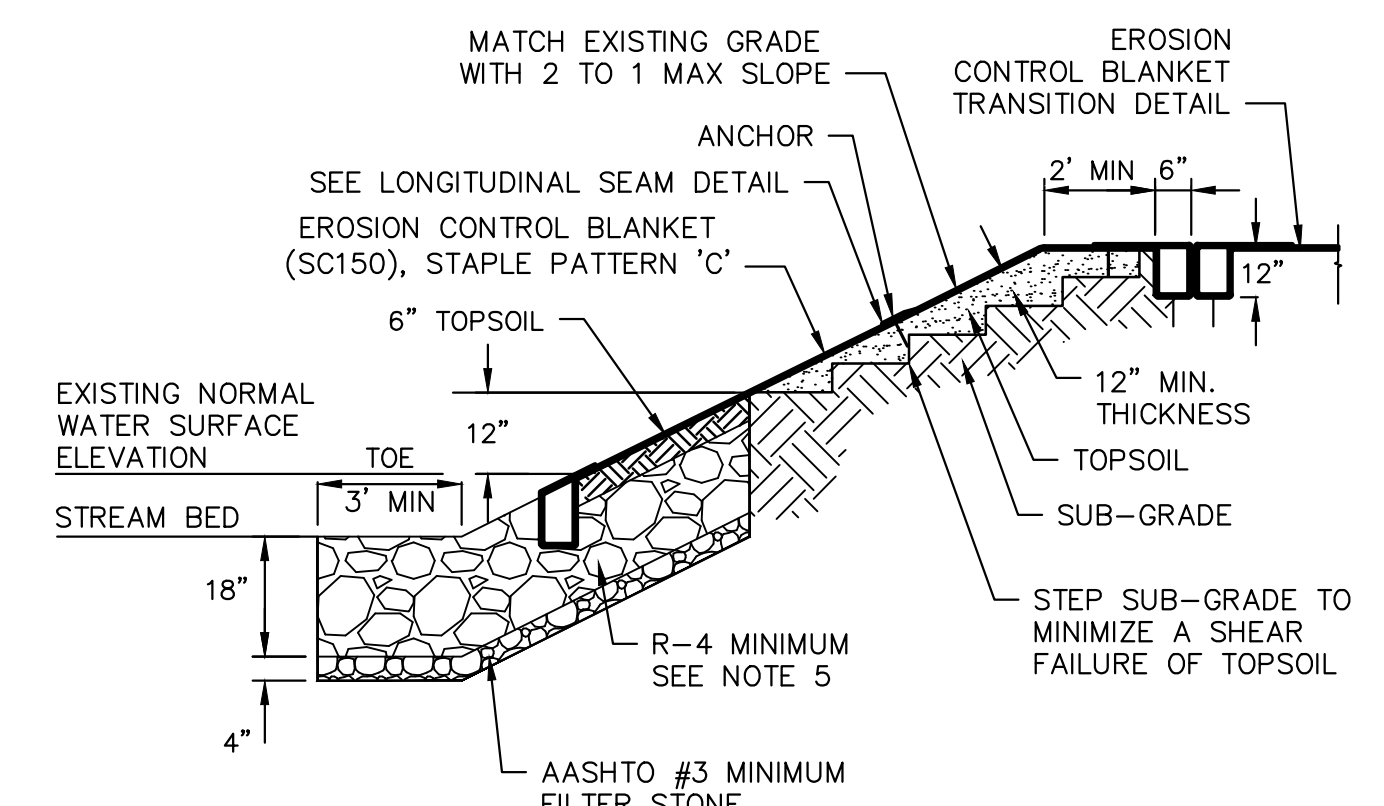

- NOTES:**
- A SUITABLE WOVEN OR NON-WOVEN GEOTEXTILE UNDERLAYMENT MUST BE USED IN ACCORDANCE TO MANUFACTURER'S RECOMMENDATIONS.
 - REFER TO NORTH AMERICAN GREEN DETAILS.
 - MATting WILL EXTEND FROM TOP OF BANK 50' PERPENDICULARLY AWAY FROM TOP OF BANK OR 100' IN HQ/EV WATERSHEDS.
 - NATURAL STREAM BED MATERIAL TO BE STRIPPED AND SEGREGATED FROM SUBSURFACE MATERIAL FOR FINAL STREAMBED RESTORATION.
 - WHERE NATURAL STONE IS REMOVED FROM THE STREAM CROSSING, NATURAL STONE SHALL BE INSTALLED AS TOP 6 INCHES OF RIPRAP.

RIP-RAP BANK STABILIZATION DETAIL
NOT TO SCALE

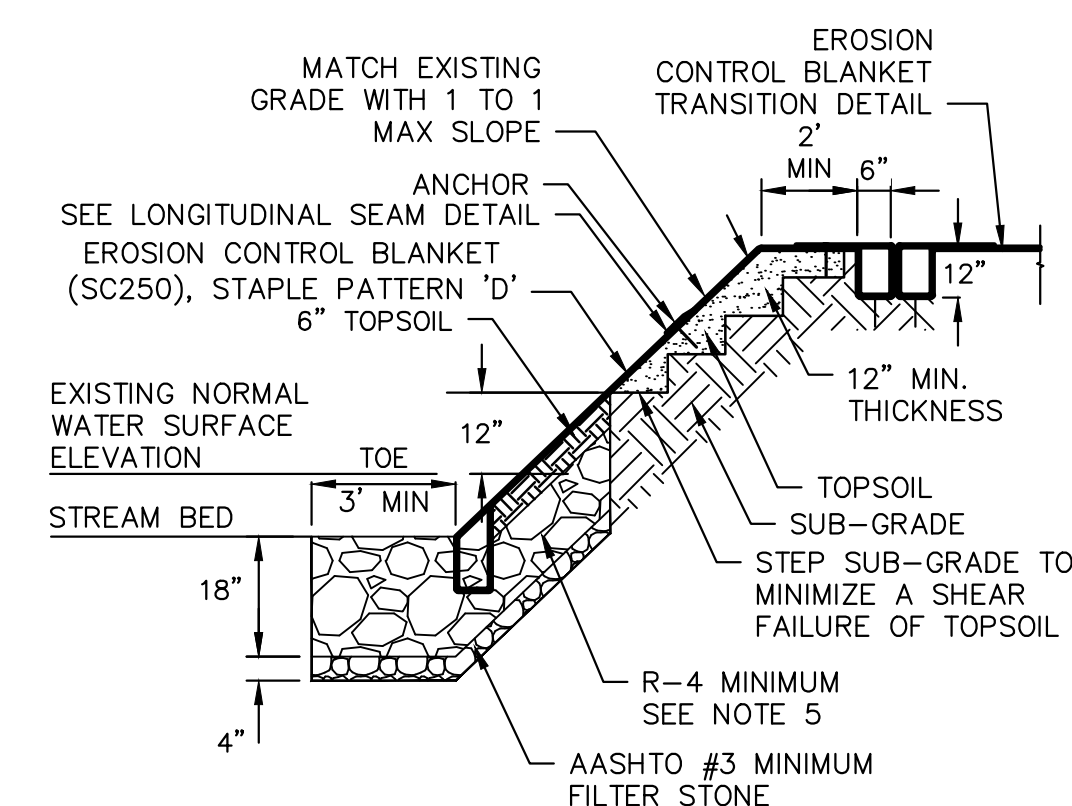

- NOTES:**
- A SUITABLE WOVEN OR NON-WOVEN GEOTEXTILE UNDERLAYMENT MUST BE USED IN ACCORDANCE TO MANUFACTURER'S RECOMMENDATIONS.
 - REFER TO NORTH AMERICAN GREEN DETAILS.
 - MATting WILL EXTEND FROM TOP OF BANK 50' PERPENDICULARLY AWAY FROM TOP OF BANK OR 100' IN HQ/EV WATERSHEDS.
 - NATURAL STREAM BED MATERIAL TO BE STRIPPED AND SEGREGATED FROM SUBSURFACE MATERIAL FOR FINAL STREAMBED RESTORATION.
 - WHERE NATURAL STONE IS REMOVED FROM THE STREAM CROSSING, NATURAL STONE SHALL BE INSTALLED AS TOP 6 INCHES OF RIPRAP.
 - FOR SLOPES GREATER THAN 1:1 REFER TO SITE SPECIFIC PLANS FOR APPROPRIATE CONTROLS.

STEEP BANK STABILIZATION DETAIL
NOT TO SCALE

TETRA TECH
www.tetrattech.com
661 ANDERSEN DRIVE - FOSTER PLAZA 7
PITTSBURGH, PA 15220
T: (412) 921-7090 | F: (412) 921-4040

REVISIONS			
NO.	BY	DATE	REMARKS

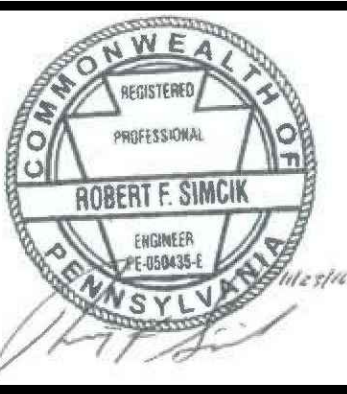

SUNOCO PIPELINE L.P.
SINKING SPRING, PENNSYLVANIA
PENNSYLVANIA PIPELINE PROJECT
CONSTRUCTION SPREAD 3

1-16" & 1-20" PROPOSED WELDED STEEL NATURAL GAS LIQUIDS PIPELINES
HUNTINGDON COUNTY CONSERVATION DISTRICT
EROSION & SEDIMENT CONTROL &
SITE RESTORATION PLAN
NOTES & DETAILS

DATE:	NOVEMBER 2016
PROJECT NO.:	112IC05958
DESIGNED BY:	JB
DRAWN BY:	BH
CHECKED BY:	RS
COPYRIGHT:	TETRA TECH INC.
ES-0.20	
SHEET:	0.20 OF 111

SITE RESTORATION GENERAL NOTES:

1. TOPOGRAPHIC MAPPING AND FEATURES COMPILED FROM WWW.PASDA.PSU.EDU.
2. THE PROJECT TAKES PLACE WITHIN HUNTINGDON COUNTY, PENNSYLVANIA.
3. TOWNSHIP BOUNDARIES TAKEN FROM WWW.PASDA.PSU.EDU.
4. 100-YEAR FEMA FLOODPLAINS TAKEN FROM WWW.PASDA.PSU.EDU.
5. SEE SHEET ES-0.02 FOR STREAM AND WETLAND CROSSING TABLE.
6. PIPELINE LOCATION AND RIGHT-OF-WAY FROM SUNOCO PIPELINE L.P.
7. USE COMPOST FILTER SOCK AS REQUIRED TO PREVENT RUNOFF FROM SPOIL AREA.
8. AT ALL STREAM CROSSINGS, RUNOFF MUST BE DIRECTED TO A SEDIMENT REMOVAL AREA (I.E. COMPOST FILTER SOCKS).
9. THE RIGHTS-OF-WAYS AND EASEMENTS SHOWN ON THIS PLAN ARE THE RESPONSIBILITY OF SUNOCO PIPELINE L.P. TO SECURE WITH THE INDIVIDUAL PROPERTY OWNER. THE RIGHTS-OF-WAY AND EASEMENTS SHOWN ON THIS PERMIT DRAWING REPRESENT THE BEST AVAILABLE PROPERTY INFORMATION AS PROVIDED TO TETRA TECH, INC. BY SUNOCO PIPELINE L.P. THE RIGHTS-OF-WAY AND EASEMENTS SHALL BE VERIFIED AND LOCATED IN THE FIELD BY SUNOCO PIPELINE L.P.
10. PAST AND PRESENT LAND USE CONSISTS OF AGRICULTURAL, FORESTED AND RESIDENTIAL AREAS. POST CONSTRUCTION LAND USE WILL BE A MAINTAINED, VEGETATED RIGHT-OF-WAY.
11. DRAWINGS REPRESENT THE FINAL PLAN FOR CONSTRUCTION.
12. THE EROSION & SEDIMENT CONTROL PLAN AND SITE RESTORATION PLAN, INSPECTION REPORTS, AND MONITORING REPORTS MUST BE AVAILABLE AT THE PROJECT SITE FOR REVIEW AND INSPECTION BY THE DEPARTMENT OR CONSERVATION DISTRICT.

SITE RESTORATION SCHEDULE:

1. AGRICULTURAL LIME APPLICATION RATES WILL BE DETERMINED BY FIELD PH TESTING. TESTING WILL BE PERFORMED AT A RATE OF 1 TEST/ACRE (MIN). IN ABSENCE OF FIELD TESTING, APPLY AT 6 TONS/ACRE.
2. APPLY 10-20-20 FERTILIZER AT THE RATE OF 1,000 LB/ACRE, OR AT A RATE DETERMINED BY FIELD TESTING.
3. WORK IN LIME AND FERTILIZER TO A DEPTH OF 4 IN. USING SUITABLE EQUIPMENT.
4. SEED PER PERMANENT SEED MIXTURE.
5. STRAW MULCH SHALL BE APPLIED AT THE RATE OF THREE TONS PER ACRE. CHEMICALLY TREATED OR SALTED STRAW IS NOT ACCEPTABLE AS MULCH.

SITE RESTORATION:

FOLLOWING COMPLETION OF PIPELINE INSTALLATION AND TRENCH BACKFILLING, THE AREA SHALL BE RETURNED TO GENERAL PRECONSTRUCTION GRADES PRESENT PRIOR TO PIPELINE INSTALLATION IN ORDER TO MAINTAIN PRECONSTRUCTION DRAINAGE PATTERNS. GROUNDS DISTURBED BY ANY OF THE OPERATIONS NECESSARY TO COMPLETE THE WORK FOR THIS PROJECT ARE TO BE PERMANENTLY SEEDED, OR IF SPECIFIED, SODDED, UNLESS OCCUPIED BY STRUCTURES, PAVED, OR DESIGNATED AS A PERMANENT ACCESS ROAD. THE ENTIRE RIGHT-OF-WAY WILL BE RESTORED BACK TO A MEADOW CONDITION OR LAWN IN ACCORDANCE WITH THE PERMANENT REVEGETATION PLAN ON ES-0.04. A TEMPORARY CESSATION OF EARTH DISTURBANCE ACTIVITIES THAT LASTS FOUR DAYS OR LONGER REQUIRES TEMPORARY STABILIZATION. DISTURBED AREAS, WHICH ARE AT FINAL GRADE, SHALL BE SEEDED AND MULCHED IMMEDIATELY, WITH THE EXCEPTION OF THE PERMANENT ACCESS ROADS. IF SEEDING CANNOT BE COMPLETED IMMEDIATELY AFTER THE AREA REACHES FINAL GRADE DUE TO WEATHER CONDITIONS, THE DISTURBED AREA SHALL BE STABILIZED AND MULCHED WITH STRAW AT THE RATE OF THREE TONS PER ACRE. THIS STRAW SHALL BE ANCHORED USING A METHOD DESCRIBED UNDER MULCHING OF THIS NARRATIVE. TEMPORARY ACCESS ROADS WILL BE RESTORED TO A VEGETATED CONDITION FOLLOWING CONSTRUCTION. THE PROPOSED PERMANENT ACCESS ROADS WILL REMAIN IN PLACE FOLLOWING CONSTRUCTION.



www.tetrattech.com
661 ANDERSEN DRIVE - FOSTER PLAZA 7
PITTSBURGH, PA 15220
T: (412) 921-7090 | F: (412) 921-4040

REVISIONS			
NO.	BY	DATE	REMARKS

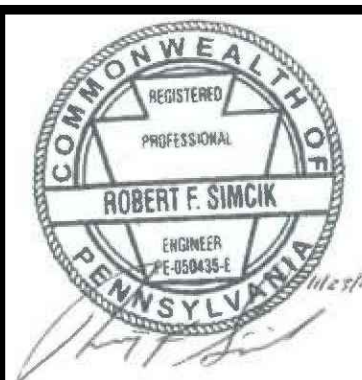

SUNOCO PIPELINE L.P.
SINKING SPRING, PENNSYLVANIA
**PENNSYLVANIA PIPELINE PROJECT
CONSTRUCTION SPREAD 3**

1-16" & 1-20" PROPOSED WELDED STEEL NATURAL GAS LIQUIDS PIPELINES
HUNTINGDON COUNTY CONSERVATION DISTRICT
EROSION & SEDIMENT CONTROL &
SITE RESTORATION PLAN
NOTES & DETAILS

DATE:	NOVEMBER 2016
PROJECT NO.:	112IC05958
DESIGNED BY:	JB
DRAWN BY:	BH
CHECKED BY:	RS
COPYRIGHT TETRA TECH INC.	
ES-0.21	
SHEET 0.21 OF 111	

NOTES:

1. TOPOGRAPHIC MAPPING AND FEATURES COMPILED FROM WWW.PASDA.PSU.EDU.
2. THE PROJECT TAKES PLACE WITHIN HUNTINGDON COUNTY, PENNSYLVANIA.
3. TOWNSHIP BOUNDARIES TAKEN FROM WWW.PASDA.PSU.EDU.
4. 100-YEAR FEMA FLOODPLAINS FROM WWW.PASDA.PSU.EDU.
5. PIPELINE LOCATION AND RIGHT-OF-WAY FROM SUNOCO PIPELINE L.P.
6. USE COMPOST FILTER SOCK AS REQUIRED TO PREVENT RUNOFF FROM SPOIL AREA.
7. AT ALL STREAM CROSSINGS, RUNOFF MUST BE DIRECTED TO A SEDIMENT REMOVAL AREA (i.e. COMPOST FILTER SOCKS).
8. THE RIGHTS-OF-WAYS AND EASEMENTS SHOWN ON THIS PLAN ARE THE RESPONSIBILITY OF SUNOCO PIPELINE L.P. TO SECURE WITH THE INDIVIDUAL PROPERTY OWNER. THE RIGHTS-OF-WAY AND EASEMENTS SHOWN ON THIS PERMIT DRAWING REPRESENT THE BEST AVAILABLE PROPERTY INFORMATION AS PROVIDED TO TETRA TECH, INC. BY SUNOCO PIPELINE L.P. THE RIGHTS-OF-WAY AND EASEMENTS SHALL BE VERIFIED AND LOCATED IN THE FIELD BY SUNOCO PIPELINE L.P.
9. PAST AND PRESENT LAND USE CONSISTS OF AGRICULTURAL, FORESTED AND RESIDENTIAL AREAS. POST CONSTRUCTION LAND USE WILL BE A MAINTAINED, VEGETATED RIGHT-OF-WAY.
10. DRAWINGS REPRESENT THE FINAL PLAN FOR CONSTRUCTION.
11. THE EROSION & SEDIMENT CONTROL PLAN AND SITE RESTORATION PLAN, INSPECTION REPORTS, AND MONITORING REPORTS MUST BE AVAILABLE FOR REVIEW AND INSPECTION BY THE DEPARTMENT OR CONSERVATION DISTRICT.
12. THE LICENSED PROFESSIONAL OR DESIGNEE SHALL BE PRESENT ON SITE FOR THE CONSTRUCTION OF THE INFILTRATION BERMS AND TRENCHES.
13. A RECORDED INSTRUMENT WILL BE RECORDED AT THE RECORDER OF DEEDS TO PROVIDE FOR NECESSARY ACCESS FOR LONG TERM OPERATION AND MAINTENANCE FOR PCSM BMP'S. THE DEED WILL PROVIDE NOTICE THAT THE RESPONSIBILITY FOR THE LONG TERM OPERATION AND MAINTENANCE OF THE PCSM BMP'S IS A COVENANT THAT RUNS WITH THE LAND AND IS BINDING AND ENFORCEABLE BY SUBSEQUENT GRANTEEES.

SITE RESTORATION

FOLLOWING COMPLETION OF PIPELINE INSTALLATION AND TRENCH BACKFILLING, THE PIPELINE RIGHT OF WAY, ASSOCIATED WORKSPACES, AND TEMPORARY ACCESS ROADS SHALL BE RETURNED TO THE GENERAL GRADE PRESENT PRIOR TO PIPELINE INSTALLATION IN ORDER TO MAINTAIN PRECONSTRUCTION DRAINAGE PATTERNS. AFTER COMPLETION OF MAJOR CONSTRUCTION WORK, TOPSOIL THAT WAS STOCKPILED DURING CONSTRUCTION WILL BE PLACED ALONG THE ROW. GROUNDS DISTURBED BY ANY OF THE OPERATIONS NECESSARY TO COMPLETE THE WORK FOR THIS PROJECT ARE TO BE PERMANENTLY SEEDED, OR IF SPECIFIED, SODDED, UNLESS OCCUPIED BY STRUCTURES, PAVED OR DESIGNATED AS A PERMANENT ACCESS ROAD. DISTURBED AREAS, WHICH ARE AT FINAL GRADE, SHALL BE SEEDED AND MULCHED ONCE FINAL GRADES ARE ACHIEVED. THE PERMANENT SEED MIXTURE WILL RESTORE DISTURBED AREAS TO A MEADOW IN GOOD CONDITION OR BETTER. IF SEEDING CANNOT BE COMPLETED WITHIN A FOUR (4) DAY PERIOD DUE TO WEATHER CONDITIONS, THE DISTURBED AREA WILL BE MULCHED WITH STRAW AT THE RATE OF THREE (3) TONS PER ACRE. THIS STRAW WILL BE ANCHORED USING A METHOD OUTLINED ON DRAWING PCS-0.03.

SITE RESTORATION CONSTRUCTION SEQUENCE

A GENERALIZED CONSTRUCTION SEQUENCE IS PROVIDED BELOW. THE CONSTRUCTION SEQUENCE IS INTENDED TO PROVIDE A GENERAL COURSE OF ACTION TO CONFORM TO THE APPLICABLE REGULATORY AGENCY REQUIREMENTS FOR SITE RESTORATION AND POST-CONSTRUCTION STORMWATER MANAGEMENT OF THE SITE. NECESSARY STEPS FOR PROPER AND COMPLETE EXECUTION OF WORK PERTAINING TO THIS PLAN, WHETHER SPECIFICALLY MENTIONED OR NOT, ARE TO BE PERFORMED BY THE CONTRACTOR. THE CONTRACTOR WILL COMPLY WITH ALL REQUIREMENTS LISTED IN THIS SECTION. THE CONTRACTOR MAY BE REQUIRED TO ALTER CONTROLS BASED ON THE EFFECTIVENESS OF CONTROLS OR DIFFERING CONDITIONS ENCOUNTERED IN THE FIELD. THE APPROPRIATE COUNTY CONSERVATION DISTRICT AND DEP SHALL BE CONTACTED AND MUST APPROVE ANY DEVIATION TO THE AUTHORIZED PLANS. A PRE-CONSTRUCTION MEETING IS REQUIRED PRIOR TO THE START OF ANY CONSTRUCTION ACTIVITY. THE PENNSYLVANIA DEPARTMENT OF ENVIRONMENTAL PROTECTION (PADEP) OR APPLICABLE COUNTY CONSERVATION DISTRICT, CONTRACTORS, THE LANDOWNER, APPROPRIATE MUNICIPAL OFFICIALS, AND THE PLAN PREPARER MUST BE INVITED TO THIS MEETING AT LEAST 7 DAYS IN ADVANCE.

1. GRADE SURFACE TO FINISHED GRADE ELEVATIONS AS SOON AS PRACTICABLE FOLLOWING COMPLETION OF PIPE INSTALLATION.
2. SURFACE ROUGHENING WILL BE UTILIZED TO ROUGH THE SOIL SURFACE WITH HORIZONTAL DEPRESSIONS FOR THE PURPOSE OF REDUCING RUNOFF VELOCITY, INCREASING INFILTRATION, AIDING THE ESTABLISHMENT OF VEGETATION, AND REDUCING EROSION. SURFACE ROUGHENING SHOULD BE APPLIED TO SLOPES 3H:1V OR STEEPER UNLESS A STABLE ROCK FACE IS PROVIDED OR IT CAN BE SHOWN THAT THERE IS NOT A POTENTIAL FOR SEDIMENT POLLUTION TO SURFACE WATERS. FOR ROUGHENED SURFACES WITHIN 50 FEET OF A SURFACE WATER, AND WHERE BLANKETING OF SEEDED AREAS IS PROPOSED AS THE MEANS TO ACHIEVING PERMANENT STABILIZATION, SPRAY-ON TYPE BLANKETS ARE RECOMMENDED. SURFACE ROUGHENING SHALL BE ACCOMPLISHED USING DOZERS AFFIXED WITH GROUSER TRACKED EQUIPMENT. DOZERS SHALL RUN UP AND DOWN THE SLOPES LEAVING HORIZONTAL GROOVES PERPENDICULAR TO THE SLOPE. DOZER BLADES SHALL BE RAISED AND NOT USED DURING SURFACE ROUGHENING. WHERE COMPACTION DOES OCCUR, CONTRACTOR SHALL SCARIFY THE SOIL OR PROVIDE ADDITIONAL ROUGHENING SUCH AS DEEP RIPPING OR CHISEL RIPPING TO RESTORE THE AREA TO A MINIMAL COMPACTED STATE. IN AREAS OF PROPOSED INFILTRATION, SOILS SHALL BE AMENDED TO 2' BELOW GRADE. SEE SOIL AMENDMENT AND RESTORATION CONSTRUCTION SEQUENCE BELOW.
3. PLACE TOPSOIL FROM TOPSOIL STOCKPILES AS THE UPPER LAYER OF BACKFILL. TOPSOIL SHALL NOT BE PLACED WHEN THE SUBGRADE IS FROZEN OR WHEN IT IS EXCESSIVELY WET OR DRY AND SHALL NOT BE HANDLED WHEN IN A FROZEN OR MUDDY CONDITION.
4. REMOVE GRAVEL AND GEOTEXTILE FROM THE TEMPORARY ACCESS ROADS AND SCARIFY THE SOIL. REFER TO STEP 2 OF THIS SEQUENCE TO ADDRESS COMPACTION AT ACCESS ROADS. AFTER ADDRESSING COMPACTION CONCERNS, PLACE TOPSOIL THAT WAS STRIPPED PRIOR TO INSTALLATION OF THE ACCESS ROADS.
5. IMMEDIATELY SEED AND MULCH DISTURBED AREAS IN ACCORDANCE WITH THE PERMANENT SEEDING SCHEDULE ONCE FINAL GRADE IS ESTABLISHED AND TOPSOIL IS PLACED.
6. MAINTAIN EROSION AND SEDIMENTATION CONTROL DEVICES UNTIL SITE WORK IS COMPLETE AND A UNIFORM 70-PERCENT PERENNIAL VEGETATIVE COVER IS ESTABLISHED. REGRADE AND REVEGETATE AREAS DISTURBED DURING THE REMOVAL OF THE EROSION AND SEDIMENT CONTROLS.

GEOWEB CONSTRUCTION SEQUENCE

1. GRADE SURFACE TO SUBGRADE ELEVATIONS AS SOON AS PRACTICABLE FOLLOWING COMPLETION OF PIPE INSTALLATION. DO NOT COMPACT.
2. IF NEEDED, SCARIFY THE SOIL OR PROVIDE ADDITIONAL ROUGHENING SUCH AS DEEP RIPPING OR CHISEL RIPPING TO RESTORE THE AREA TO A MINIMAL COMPACTED STATE.
3. INSTALL GEOTEXTILE SEPARATION LAYER IN ACCORDANCE WITH MANUFACTURER'S RECOMMENDATIONS.
4. EXPAND GEOWEB TO REQUIRED DIMENSIONS AND ANCHOR EDGES WITH ATRA ANCHORS, IF NEEDED. JOIN ADJACENT SECTIONS WITH ATRA KEYS.
5. ANCHOR GEOWEB ON SLOPES GREATER THAN 5% WITH 24" ATRA ANCHORS PLACED ON A 3X8 CELL PATTERN.
6. MIX AND PLACE ENGINEERED INFILL MATERIAL (2/3 AASHTO #57 STONE AND 1/3 SCREENED TOPSOIL) INTO THE GEOWEB CELLS. INFILL MATERIAL SHALL BE FREE-FLOWING AND NOT FROZEN WHEN PLACED IN THE GEOWEB SECTIONS. LIMIT DROP HEIGHT TO 3 FEET TO AVOID DAMAGING OR DISPLACEMENT OF THE CELL WALL. SLIGHTLY OVERFILL THE CELLS AND LEVEL OFF MATERIAL ONCE SETTLEMENT IS NEGLIGIBLE. DO NOT COMPACT.
7. SEED AND MULCH FILLED SECTIONS IN ACCORDANCE WITH THE PERMANENT SEEDING SCHEDULE ONCE INFILL IS PLACED.
8. MAINTAIN EROSION AND SEDIMENTATION CONTROL DEVICES UNTIL SITE WORK IS COMPLETE AND A UNIFORM 70-PERCENT PERENNIAL VEGETATIVE COVER IS ESTABLISHED.

SOIL AMENDMENT AND RESTORATION CONSTRUCTION SEQUENCE

1. GRADE SURFACE TO FINISHED GRADE ELEVATIONS AS SOON AS PRACTICABLE FOLLOWING COMPLETION OF PIPE INSTALLATION.
2. IN THE DESIGNATED SOIL AMENDMENT AREA, TILL THE GROUND AND MIX IN THE COMPOST AT A RATIO OF 2:1 (SOIL:COMPOST) TO A DEPTH OF 24 INCHES.
3. IMMEDIATELY SEED AND MULCH DISTURBED AREAS ONCE FINAL GRADE IS ESTABLISHED IN ACCORDANCE WITH THE PERMANENT SEEDING SCHEDULE.
4. MAINTAIN EROSION AND SEDIMENTATION CONTROL DEVICES UNTIL SITE WORK IS COMPLETE AND A UNIFORM 70% PERENNIAL VEGETATIVE COVER IS ESTABLISHED.

POST CONSTRUCTION STORMWATER MANAGEMENT CONSTRUCTION SEQUENCE

1. GRADE SURFACE TO FINISHED GRADE ELEVATIONS AS SOON AS PRACTICABLE FOLLOWING COMPLETION OF PIPE INSTALLATION.
2. INSTALL POST CONSTRUCTION BMPS AFTER COMPLETION OF PIPELINE CONSTRUCTION:

INFILTRATION BERM

1. INSTALL TEMPORARY SEDIMENT AND EROSION CONTROL BMPS AS PER THE PENNSYLVANIA EROSION AND SEDIMENT POLLUTION CONTROL PROGRAM MANUAL.
2. INSTALL ORANGE CONSTRUCTION FENCING AROUND THE PONDING AREA OF THE INFILTRATION BERM AS SHOWN ON THE PCSM PLAN DRAWINGS. COMPLETE SITE GRADING AND STABILIZE WITHIN THE LIMIT OF DISTURBANCE EXCEPT WHERE THE INFILTRATION BERM WILL BE CONSTRUCTED AND THE EXTENT OF THE PONDING AREA; MAKE EVERY EFFORT TO MINIMIZE BERM FOOTPRINT AND NECESSARY ZONE OF DISTURBANCE (INCLUDING BOTH REMOVAL OF EXISTING VEGETATION AND DISTURBANCE OF EMPTY SOIL) IN ORDER TO MAXIMIZE INFILTRATION. IF EQUIPMENT MUST TRAVEL THROUGH THE PONDING AREA, TIMBER MATTING SHALL BE PLACED TO MINIMIZE COMPACTION, AND EQUIPMENT TRAFFIC SHALL BE MINIMIZED.
3. LIGHTLY SCARIFY THE SOIL IN THE AREA OF THE PROPOSED BERM BEFORE DELIVERING SOIL TO SITE.
4. BRING IN FILL MATERIAL TO MAKE UP THE MAJOR PORTION OF THE BERM. SOIL SHOULD BE ADDED IN 8-INCH LIFTS AND COMPACTED AFTER EACH ADDITION ACCORDING TO DESIGN SPECIFICATIONS. THE SLOPE AND SHAPE OF THE BERM SHOULD BE GRADED OUT AS SOIL IS ADDED.
5. PROTECT THE SURFACE PONDING AREA AT THE BASE OF THE BERM FROM COMPACTION.
6. COMPLETE FINAL GRADING OF THE BERM AFTER THE TOP LAYER OF SOIL IS ADDED. TAMP SOIL DOWN LIGHTLY AND SMOOTH SIDES OF THE BERM. THE CREST AND BASE OF THE BERM SHOULD BE AT LEVEL GRADE.
7. PLANT BERM WITH TURF, MEADOW PLANTS, SHRUBS OR TREES, AS DESIRED.
8. MULCH PLANTED AND DISTURBED AREAS WITH COMPOST MULCH TO PREVENT EROSION WHILE PLANTS BECOME ESTABLISHED.

INFILTRATION TRENCH

1. INSTALL AND MAINTAIN PROPER EROSION AND SEDIMENT CONTROL MEASURES DURING CONSTRUCTION.
2. GRADE SURFACE TO FINISHED GRADE ELEVATIONS AS SOON AS PRACTICABLE.
3. PROTECT INFILTRATION TRENCH AREA FROM COMPACTION PRIOR TO INSTALLATION. INSTALL ORANGE CONSTRUCTION FENCE AROUND THE TRENCH AND, IF APPLICABLE, THE PONDING AREA OF THE DOWNSLOPE BERM.
4. IF POSSIBLE, INSTALL INFILTRATION TRENCH DURING LATER PHASES OF SITE CONSTRUCTION TO PREVENT SEDIMENTATION AND/OR DAMAGE FROM CONSTRUCTION ACTIVITY. AFTER INSTALLATION, PREVENT SEDIMENT LADEN WATER FROM ENTERING INLETS AND PIPES. IF IT IS NOT POSSIBLE TO INSTALL THE INFILTRATION TRENCH DURING THE LATER PHASES OF CONSTRUCTION, PLACE COMPOST FILTER SOCK UPSLOPE OF THE TRENCH TO PREVENT SEDIMENT FROM REACHING AND CLOGGING THE TRENCH.
5. EXCAVATE INFILTRATION TRENCH BOTTOM TO A UNIFORM, LEVEL UNCOMPACTED SUBGRADE FREE FROM ROCKS AND DEBRIS. DO NOT COMPACT SUBGRADE. THE CONSTRUCTION EQUIPMENT SHALL REMAIN OUTSIDE OF THE INFILTRATION TRENCH WHILE EXCAVATING IT.
6. PLACE NONWOVEN GEOTEXTILE ALONG BOTTOM AND SIDES OF TRENCH. NONWOVEN GEOTEXTILE ROLLS SHOULD OVERLAP BY A MINIMUM OF 16 INCHES WITHIN THE TRENCH. FOLD BACK AND SECURE EXCESS GEOTEXTILE DURING STONE PLACEMENT.
7. INSTALL UPSTREAM AND DOWNSTREAM CONTROL STRUCTURES, CLEANOUTS, ETC.
8. PLACE UNIFORMLY GRADED, CLEAN-WASHED AGGREGATE IN 8-INCH LIFTS, LIGHTLY COMPACTING BETWEEN LIFTS. LIGHT COMPACTION SHALL ENSURE THE AGGREGATE WON'T SETTLE BELOW THE INTENDED TOP ELEVATION OF THE TRENCH. CARE SHALL BE TAKEN SO AS NOT TO COMPACT THE SUBGRADE.
9. INSTALL CONTINUOUSLY PERFORATED PIPE AS INDICATED ON PLANS. BACKFILL WITH UNIFORMLY GRADED, CLEAN-WASHED AGGREGATE IN 8-INCH LIFTS, LIGHTLY COMPACTING BETWEEN LIFTS. LIGHT COMPACTION SHALL ENSURE THE AGGREGATE WON'T SETTLE BELOW THE INTENDED TOP ELEVATION OF THE TRENCH. CARE SHALL BE TAKEN SO AS NOT TO COMPACT THE SUBGRADE.
10. FOLD AND SECURE NONWOVEN GEOTEXTILE OVER INFILTRATION TRENCH, WITH MINIMUM OVERLAP OF 16- INCHES.
11. PLACE 6-INCH LIFT OF APPROVED TOPSOIL OVER INFILTRATION TRENCH, AS INDICATED ON PLANS.
12. SEED AND STABILIZE TOPSOIL.
13. ANY SEDIMENT THAT ENTERS INLETS DURING CONSTRUCTION IS TO BE REMOVED WITHIN 24 HOURS.
14. IMMEDIATELY SEED AND MULCH DISTURBED AREAS ONCE FINAL GRADE IS ESTABLISHED IN ACCORDANCE WITH THE PERMANENT SEEDING SCHEDULE.
15. MAINTAIN EROSION AND SEDIMENTATION CONTROL DEVICES UNTIL SITE WORK IS COMPLETE AND A UNIFORM 70% PERENNIAL VEGETATIVE COVER IS ESTABLISHED.
16. REMOVE EROSION SEDIMENT CONTROL MEASURES UPON ESTABLISHMENT OF A UNIFORM 70% VEGETATIVE COVER OVER THE DISTURBED AREA. RE-GRADE AND REVEGETATE AREAS DISTURBED DURING THE REMOVAL OF THE EROSION AND SEDIMENT CONTROLS.

SOIL AMENDMENT AND RESTORATION

1. GRADE SURFACE TO FINISHED GRADE ELEVATIONS AS SOON AS PRACTICABLE FOLLOWING COMPLETION OF PIPE INSTALLATION.
2. IN THE DESIGNATED SOIL AMENDMENT AREA, TILL THE GROUND AND MIX IN THE COMPOST AT A RATIO OF 2:1 (SOIL:COMPOST) TO A DEPTH OF 24 INCHES.
3. IMMEDIATELY SEED AND MULCH DISTURBED AREAS ONCE FINAL GRADE IS ESTABLISHED IN ACCORDANCE WITH THE PERMANENT SEEDING SCHEDULE.
4. MAINTAIN EROSION AND SEDIMENTATION CONTROL DEVICES UNTIL SITE WORK IS COMPLETE AND A UNIFORM 70% PERENNIAL VEGETATIVE COVER IS ESTABLISHED.



661 ANDERSEN DRIVE - FOSTER PLAZA 7
PITTSBURGH, PA 15220
T: (412) 921-7090 | F: (412) 921-4040

REVISIONS			
NO.	BY	DATE	REMARKS

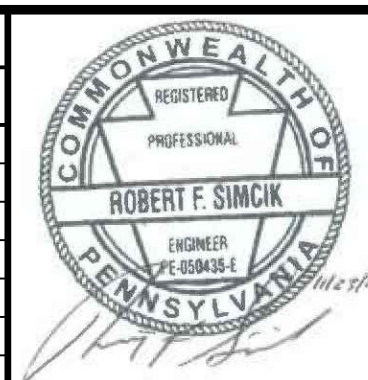

SUNOCO PIPELINE L.P.
SINKING SPRING, PENNSYLVANIA
**PENNSYLVANIA PIPELINE PROJECT
CONSTRUCTION SPREAD 3**

1-16" & 1-20" PROPOSED WELDED STEEL NATURAL GAS LIQUIDS PIPELINES
HUNTINGDON COUNTY CONSERVATION DISTRICT
EROSION & SEDIMENT CONTROL &
SITE RESTORATION PLAN
NOTES & DETAILS

DATE:	NOVEMBER 2016
PROJECT NO.:	112IC05958
DESIGNED BY:	JB
DRAWN BY:	BH
CHECKED BY:	RS
COPYRIGHT TETRA TECH INC.	
ES-0.22	
SHEET 0.22 OF 111	

