



TETRA TECH

REV 1 – 7/21/2016

**METERING PLAN FOR
CONESTOGA RIVER (PRIMARY)**

ATLANTIC SUNRISE PROJECT

**Conestoga Township, Lancaster County,
Pennsylvania**

Prepared For:

**TRANSCONTINENTAL GAS PIPE LINE
COMPANY, LLC
HOUSTON, TEXAS**

Prepared By:

**TETRA TECH, INC.
PITTSBURGH, PENNSYLVANIA**

May 2016

SRBC Surface Water Withdrawal and Consumptive Use Metering Plan

A. Intake Design

The surface water withdrawal location on the Conestoga River is located near the proposed gas pipeline route where the water will be required for HDD boring and hydrostatic testing. Water will be transferred by truck from the Conestoga River to the location of the HDD drilling and hydrostatic testing. This water source will only be used to supply water during pipeline construction and testing. Water from this source will only be used consumptively while supplying water for the HDD bore. Transcontinental Gas Pipe Line Company, LLC (Transco) proposes to use one (1), 5-foot long, 3-inch radius aluminum screen with slot-size openings of 0.100-inch that are manufactured by Bilfinger Water Technologies™ to withdraw water from the Conestoga River. The 5-foot long screen is connected by a tee fitting and includes a foot valve. The intake structure will be connected to an 8-inch diameter flexible hose or HDPE pipe that will be used to convey water to the pump. The intake structure will be submerged in the approximate location of the river's thalweg (lowest point of river channel) in close proximity to the project site. The approximate water depth at the point of withdrawal is 2 feet. The slot openings were sized to avoid potential aquatic impacts associated with impingement and entrainment. Calculations for the intake's through-screen approach velocity (provided in Attachment A-1) show the screen entrance velocity to be less than 0.5 feet per second (ft/s). Manufacturer information for the intake screens is included in Attachment A-2.

Transco proposes to use one 4" by 3" Pioneer Prime Series PP43C10 vacuum assisted, end suction centrifugal pump. This pump is mechanically driven and operates at a maximum of 2,500 revolutions per minute. Pump specification sheets and head curves are included in Attachments A-3 and A-4, respectively. Transco will limit the instantaneous pumping rate by using a Cla Val Combination Rate of Flow Controller & Solenoid Shut-off Valve (Model 43-01) on the discharge end of the pump. Specifications are included in Attachment A-5. This valve will be locked to prevent unintentional changes to the flow rate. Transco's staff will be prepared to comply with monthly passby rates and withdrawal rates. To protect aquatic resources and downstream users, Transco will cease withdrawals from the Conestoga River when the river flow at the assigned reference gage is at or falls below prescribed passby flows.

Transco will ensure that the intake screen is regularly maintained and free of debris. Specifically, to ensure that the screen area is open and not clogged, prior to each operating event, Transco will retrieve the screen intake apparatus from the river and inspect it for any debris or material that could clog the intake and reduce pumping efficiencies. In addition, the flow rate will be monitored during operation. If the pumping flow rate decreases by 20% or more during operation, the pump will be turned off and the screen intake assembly will be retrieved from the river and inspected to ensure the screen is not clogged which could result in increased entrance velocities. If debris is present in and around the screen opening, the screen will be cleaned prior to being put back into operation.

Water will be conveyed to the Horizontal Directional Drilling (HDD) location by truck. The skid/trailer-mounted pump will be used to transfer the water to holding tanks and the trucks will be loaded from the tanks. Similarly, the water will be transferred from the trucks to holding tanks at

the HDD location. Water will be withdrawn from the tanks to use during the HDD and hydrostatic test. The intake pipe was sized to accommodate up to 500 gpm flow rate (see Attachment A-6 for basis). Any returning mud/water used for the HDD will be collected and stored in tanks, and subsequently disposed of off-site at an approved disposal facility. Water used for the HDD hydrostatic testing will be discharged at a Pennsylvania Department of Environmental Protection permitted location (i.e., PAG-10 permit). The HDD drilling and hydrostatic testing of the pipeline segment is currently scheduled to be completed by the end of 2017.

A wetland study was completed for the area on 12/14/2015. No wetlands were identified in the vicinity of the proposed intake. The intake pump will be located within the Federal Emergency Management Agency (FEMA) floodplain, but out of the FEMA floodway. The slope of the river bank at the proposed location is gradual. All equipment will be temporary and removable, minimizing impact to riparian vegetation. Portable secondary containment will be utilized around the pump. It should also be noted that the pump will be located within the Transco project right-of-way and limit-of-disturbance.

Transco intends to put in place protective controls at the withdrawal site to enforce the passby requirements set by the SRBC with the intent to protect the stream during low-flow periods. For this project, flows at the proposed withdrawal point will be estimated by proportioning based on the drainage area ratio method from a selected USGS gaging station near or on the Conestoga River. At the proposed location, the Conestoga River has a drainage area of 402 square miles (mi²). Based on that drainage area the Aquatic Resource Class (ARC) of the Conestoga River is classified as 'ARC 4', which represents a medium tributary river. Rivers classified as ARC 4 are likely to be minimally sensitive to potential impacts from withdrawals due to their large size, position in the landscape, and flow volumes.

Transco will stop or decrease withdrawals during low flow periods to avoid negatively impacting the quality of the Conestoga River. Flow rate data for a SRBC-selected stream or river located near the Conestoga River that has an active USGS gaging station will be used to determine the flow rates of the Conestoga River during surface water withdrawal operations.

B. Metering

To meter the volume of water withdrawn at the surface water withdrawal location, a 6-inch Seametrics AG2000 Irrigation Magmeter will be used (see manufacturer information in A-7). This spool-type electromagnetic flow meter and totalizer has no moving parts and minimal straight pipe requirements both above (i.e., 12 inches, minimum) and below (i.e., 6 inches, minimum) the meter. This allows unobstructed flow and makes it an ideal choice for use in surface water withdrawal applications where debris may cause damage to the equipment. This model is capable of displaying up to 5 digits for flow rate and 8 digits for the totalizer. The minimum flow rate for this model of flow meter is 32 gpm; the maximum rate is 2,400 gpm. The proposed withdrawal rate of 500 gpm is within this range. The meter is accurate to within +/-1% for flows between 240 gpm and 2400 gpm and +/- 2% for flows under 240 gpm. The flow meter will be installed so that it cannot be bypassed, zeroed, or reset.

Transco will check the totalizer daily prior to pumping water from the Conestoga River and at the end of each day to ensure that the proposed 0.360 MGD maximum daily withdrawal is not

exceeded. Transco intends to withdraw the 0.360 MGD over 12 hours each day. Transco will maintain daily records of the project's withdrawal and consumptive water use and shall report the data to the SRBC on a quarterly and annual basis, or as prescribed. Transco will also ensure that the meter readout will be accessible for SRBC staff at all times without locks, keys or other special access requirements.

To meter the volume of water withdrawn from storage and consumptively used for the HDD bore, a 4-inch Seametrics AG2000 Irrigation Magmeter will be used (see manufacturer information in A-1). This spool-type electromagnetic flow meter and totalizer has no moving parts and minimal straight pipe requirements both above (i.e., 8 inches) and below (i.e., 4 inches) the meter. This allows unobstructed flow and makes it an ideal choice for use in surface water withdrawal applications where debris may cause damage to the equipment. This model is capable of displaying up to 5 digits for flow rate and 8 digits for the totalizer. The minimum flow rate for this model of flow meter is 12 gpm; the maximum rate is 1,000 gpm. The proposed withdrawal rate of 69.44 gpm (continuous daily average) is within this range. The meter is accurate to within +/-1% for flows between 100 gpm and 1,000 gpm and +/- 2% for flows under 100 gpm. The flow meter will be installed so that it cannot be bypassed, zeroed, or reset.

Transco will check the totalizer daily prior to pumping water from the Baker storage tanks and at the end of each day to maintain an exact record of water used consumptively. Transco shall report the data to the SRBC on a quarterly and annual basis, or as prescribed. Transco will also ensure that the meter readout will be accessible for SRBC staff at all times without locks, keys or other special access requirements.

C. Plans, Details, and Maps

A site plan, cross-section, details, and location map can be found in Attachment A-8. Site Photographs are included in Attachment A-9.

A-1 Intake Screen Calculations

CLIENT: TRANSCONTINENTAL PIPE LINE COMPANY, LLC		JOB NUMBER: 212C-PB-00282	
SUBJECT: CONESTOGA RIVER PRIMARY SCREENED INTAKE EVALUATION - REV 1			
BASED ON: Bilfinger Water Technologies		DRAWING NUMBER:	
BY: JJA	CHECKED BY: LMH	REVISED BY: LMH	APPROVED BY: CAR
DATE: 11/23/2015	DATE: 12/12/15	DATE: 7/21/2016	DATE: 7/22/2016

PURPOSE:

The purpose of this calculation is to evaluate the minimum number of intake screens necessary to meet the requirement of maximum intake velocity of 0.5 feet per second. River depth is approximately 2.5 feet at the withdrawal location.

APPROACH:

Use typical industry equations to calculate the minimum number of Bilfinger Water Technologies 6-inch diameter well screens necessary to allow a flow rate of 500 gallons per minute. Assume multiple intake screens with 0.1-inch slots.

CALCULATIONS:

- (1) Data was obtained from Bilfinger Water Technologies® for the well screen.

d	=	0.100	=	Maximum perforation diameter, inches
V	=	0.5	=	Maximum intake velocity, feet per second
Q	=	500	=	Maximum flow (withdrawal) rate, gallons per minute
r	=	3.36	=	Radius of perforated intake pipe, inches
b	=	5.0	=	length of perforated intake pipe, feet
n	=	unknown	=	number of screens
A _s	=	1,267	=	Area of screen, square inches
A _o	=	792	=	Open area of screen, square inches (see attached)
P	=	62.5%	=	Open area of perforated intake pipe (P = A _o /A _s)

- (2) Use the following equation from the Handbook of Groundwater Development, Roscoe Moss Company, to calculate first the minimum number of Bilfinger Water Technologies intake screens necessary for a withdrawal of 500 gallons per minute.

$$V = \frac{Q / n}{235 \times r \times b \times P}$$

$$n = \frac{Q}{235 \times r \times b \times P \times V}$$

$$n = \frac{500}{235 \times 3.36 \times 5 \times 0.625 \times 0.5}$$

$$n = 0.41$$

$$n = 1 \quad (\text{round up})$$

The minimum number of Bilfinger Water Technologies 6-inch diameter well screens necessary to allow for a total flow of 500 gpm to be withdrawn is 1.

- (3) Using the equation from Step 2, calculate the entrance velocity when 1 Bilfinger Water Technologies 6-inch diameter well screen is used.

$$V = \frac{Q / n}{235 \times r \times b \times P}$$

$$V = \frac{500 / 1}{235 \times 3.36 \times 5 \times 0.625}$$

$$V = 0.20 \quad \text{feet per second}$$

CLIENT:	TRANSCONTINENTAL PIPE LINE COMPANY, LLC		JOB NUMBER:	212C-PB-00282			
SUBJECT:	CONESTOGA RIVER PRIMARY SCREENED INTAKE EVALUATION - REV 1						
BASED ON:	Bilfinger Water Technologies			DRAWING NUMBER:			
BY:	JJA	CHECKED BY:	LMH	REVISED BY:	LMH	APPROVED BY:	CAR
DATE:	11/23/2015	DATE:	12/12/15	DATE:	7/21/2016	DATE:	7/22/2016

CONCLUSION:

One Bilfinger Water Technologies 6-inch diameter well screen provides an intake flow capacity of 500 gallons per minute with a maximum screen entrance velocity of 0.20 feet per second, which is conservatively below the required maximum intake velocity of 0.5 feet per second. Therefore, Tetra Tech believes that the resulting velocity will minimize impingement and entrainment of aquatic organisms during operation. Additionally, to minimize sediment uptake, the intake screens will be cradled to elevate them a minimum of 6-inches off of the river bed.

A-2 Intake Manufacturer Information

SCREEN INFORMATION		
CUSTOMER	Tetra-tech	
REFERENCE		
DIAMETER	6 in	PS
MATERIAL	304 Stainless	
COLLAPSE	45	PSI
SLOT SIZE	0.100	IN
OPEN AREA	62.50%	
ROD AREA	0.864	SQ IN
HANGING WT ¹	11,000	LB
¹ MAXIMUM RECOMMENDED HANGING WEIGHT FOR THE TOP SCREEN JOINT		
LENGTH (ft)	5	FULL
NO. OF PIECES	1	Joints
TOP FITTING	1.5 in	F/NPT
BTM FITTING	1.5 in	M/NPT

* A broad range of site conditions can impact the physical strength requirements for a successful screen installation. Consult Johnson Screens with questions for successful screen installation. Consult Johnson Screens with questions regarding the parameters presented above as they relate to your specific requirements.

** Vertical weight on screen that should not be exceeded without use of rigid centralizers!

Prepared by Waterwell Sales. Subject to Bilfinger Water Technologies, Inc Standard Terms and Conditions.

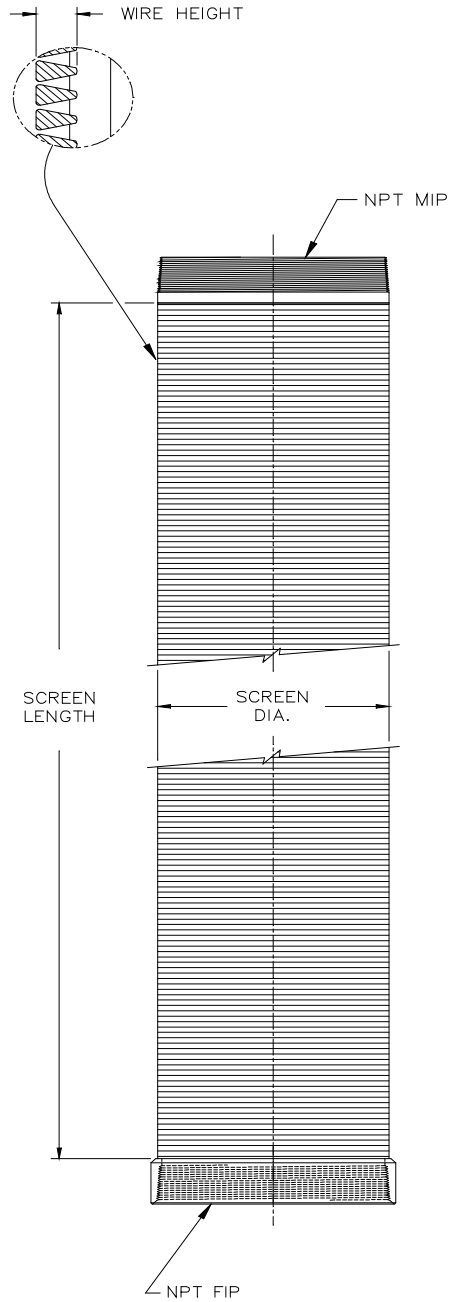

THIS DRAWING AND DESIGN DATA IS CONFIDENTIAL IN NATURE AND IS THE PROPERTY OF BILFINGER WATER TECHNOLOGIES INC, ST. PAUL, MN, USA, AND SHALL NOT BE REPRODUCED IN ANY MANNER OR USED FOR ANY PURPOSE WHATSOEVER EXCEPT BY WRITTEN PERMISSION OF BILFINGER WATER TECHNOLOGIES INC.



WELL SCREEN SUBMITTAL DATA

CLIENT: Tetra-tech
PROJECT:

Material	304 Stainless			
Nom Size	6	PS	150	mm
Top x Bottom Fitting Configuration	NPT x WR W/PB			
Estimated Total Well Depth	2	ft	1	meters
Estimated Feet of Screen	5	ft	2	meters
Design Slot Size	0.100	in	2.5	mm
Approx. Outside Diameter	6.72	in	171	mm
Screen Barrel Inside Diameter	6.18	in	157	mm
Approx. Clear ID at Fittings	6.02	in	153	mm
Approx. Weight Per Ft	6	lbs	3	kg
Wire Width	0.060	in	1.5	mm
Wire Height	0.100	in	2.5	mm
Calc. Collapse Strength *	45	PSI	3	kg/sq.cm
Open Area	62.5%			
Intake Area	158	sq.in./ft	3,349	sq.cm./meter
Transmitting Capacity-at 0.1 ft/sec	49	gpm/ft	10	lps/meter
Support Rod Diam	0.150	in	3.8	mm
No Rods	40			
Cross Sectional Rod Area	0.86	sq.in.	5.57	sq.cm.
Design Yield Strength	30,000	PSI	2,109	kg/sq.cm
Calc.Tensile Strength *	22,000	lbs	10,000	kg
Max.Recomended Hang Wt. *	11,000	lbs	5,000	kg
Column Load **	5,000	lbs	2,300	kg

* A broad range of site conditions can impact the physical strength requirements for a successful screen installation. Consult Johnson Screens with questions regarding the parameters presented above as they relate to your specific requirements.

** Vertical weight on screen that should not be exceeded without consulting manufacturer. Column load calculations should include some allowance for gravel pack contribution.

A-3 Pump Specification

Pioneer Prime

PP43C10L71



Typical Pump Configuration

Performance

Pioneer Prime series - vacuum assisted, end suction centrifugal pump

Bare shaft, frame mounted, fully automatic dry priming, vacuum assisted, run dry, heavy duty pump

Size	4" x 3" 100 x 76 mm
Flow, Max	550 USgpm 130 m ³ /h 30 l/s
Head, Max	245 feet 70 meters
Flow at BEP	375 USgpm 90 m ³ /h 20 l/s
Efficiency at BEP	72%
Solids Handling, Max	0.76" 19 mm
Operating Speed, Max	2500 rpm
Suction Connection	4" (100 mm) 150 ANSI Flanges
Delivery Connection	3" (76 mm) 150 ANSI Flanges
Bearing Lubrication	Oil STD Grease optional
Fasteners	Imperial

Applications

Oil & Gas	Construction
Industrial	Mining
Petrochemical	Rental
Agriculture	Irrigation

High flow, heavy duty pump

The PP43C10 is a high flow, ruggedized pump designed to run over a broad range of performance and deliver outstanding suction lift. The rugged construction and modular design provide proven reliability and flexibility in the most demanding applications.

UltraPrime™ Priming System

Priming System	Mechanically Driven Diaphragm Style Vacuum Pump
Air Removal Capability	50 CFM
Priming Chamber	Single chamber with positive sealing air separation PosiValve™ with stainless steel float ball & linkage.
Discharge Check Valve	Swing Style - ductile iron with Buna-n Disc

Other Specifications

Mechanical Seal	Single seal w/ tungsten carbide vs. silicon carbide seal faces, Viton® elastomers, 300 series stainless steel hardware and spring, designed for indefinite dry running
Pump End Bearing	Single Row Ball
Drive End Bearing	Double Row Angular Contact
Shaft	17-4 PH Stainless Steel

Construction Materials

	Standard Construction	CD4MCu Stainless Steel
Impeller	CA6NM SS	CD4MCu
Volute	Ductile Iron ASTM A536 65-45-12	CD4MCu
Wear Ring	ASTM A48 Class 40 Gray Iron	316 SS
Suction Cover	Ductile Iron ASTM A536 65-45-12	CD4MCu
Brac-plate	Ductile Iron ASTM A536 65-45-12	CD4MCu

Mechanical Dimensions



Typical Pump Configuration

PP43C10

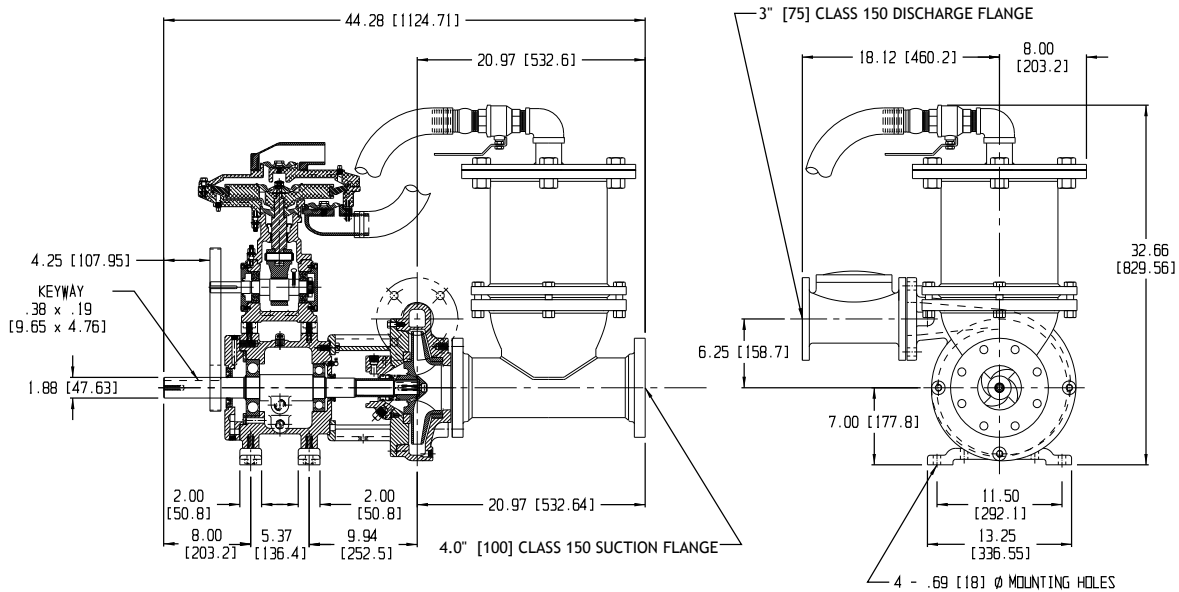

Performance Curve

Model: PP43C10	Impeller Dia: 10.25"	Speed: Variable	Solids Size: 0.76"	Curve #A4353HQ
----------------	----------------------	-----------------	--------------------	----------------

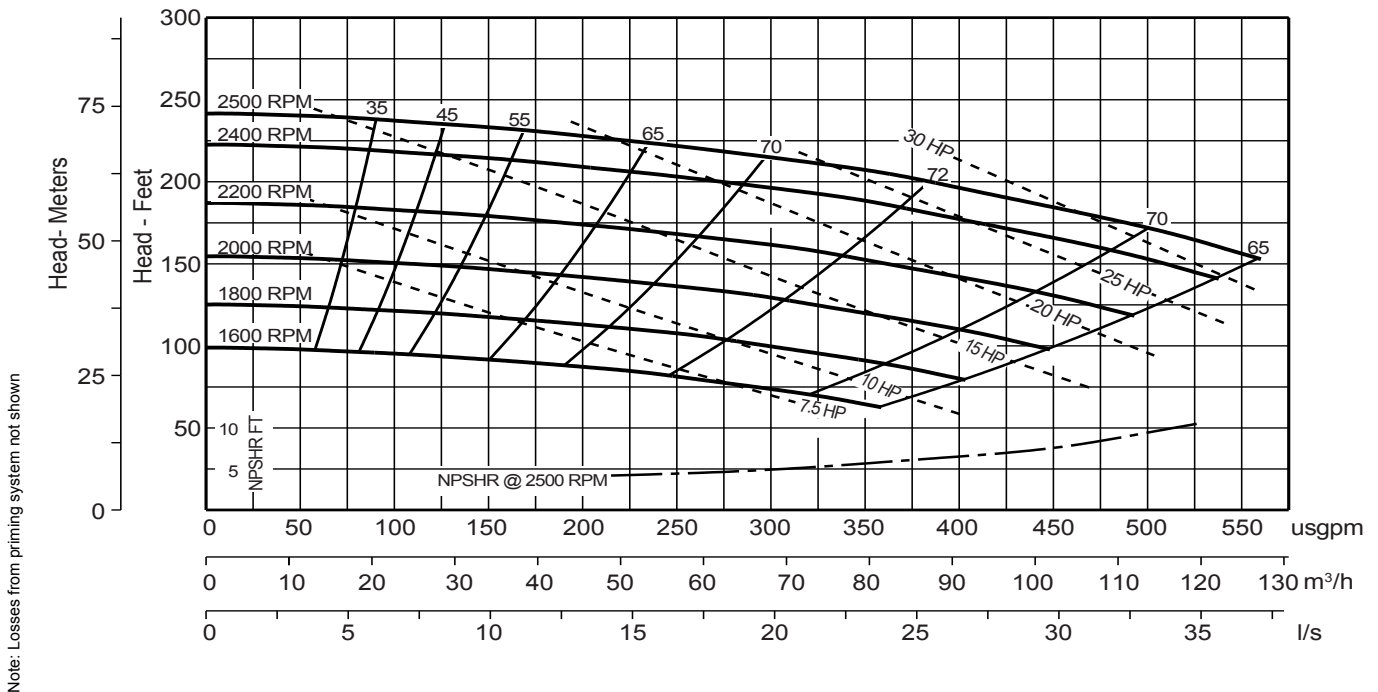

A-4 Pump Head Curves and Pump Selection Justification

Note: Losses from priming system not shown

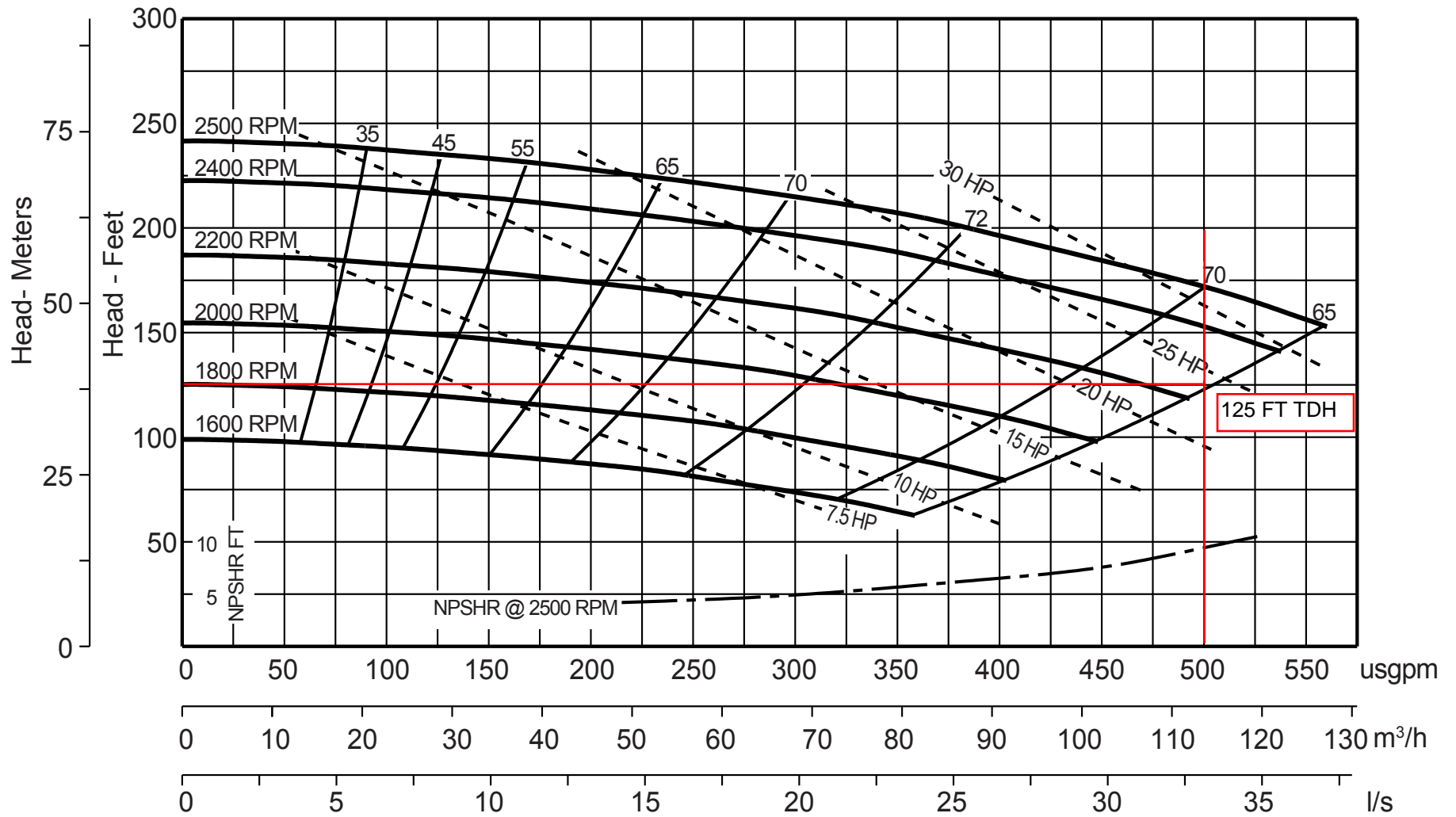

Model	PP43C10	
Size	4" x 3"	100 mm x 75 mm
Impeller Diameter	10.25"	260 mm
Solids Handling Size	.68"	17 mm

DWG No. A4353HQ
 Revision 001
 Drawn By DAP
 Date 23 Jul 2010

A-5 Flow Control Valve Specification



43-01
(Full Internal Port)

MODEL

643-01
(Reduced Internal Port)

Combination Rate of Flow Controller & Solenoid Shut-Off Valve

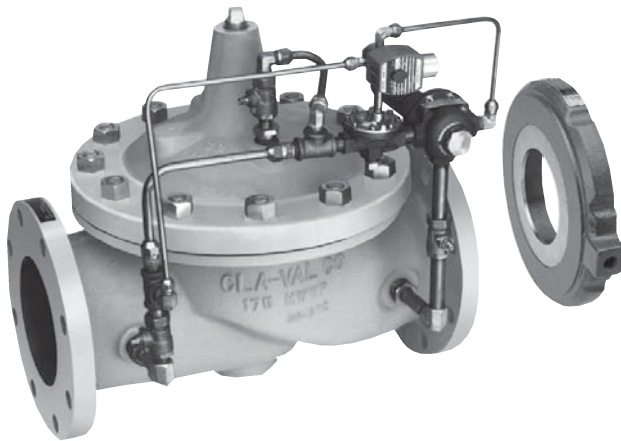

- Multi-functional Capability
- Includes Orifice Plate with Holder
- Optional Check Feature
- Easily Adjusted
- Every Valve Factory Tested

The Cla-Val Model 43-01/643-01 Combination Rate of Flow Controller and Solenoid Shut-Off Valve limits the maximum flow rate, regardless of changing line pressure. It is a hydraulically operated, pilot controlled, diaphragm valve. The pilot control is actuated by the differential pressure produced across an orifice plate installed downstream of the valve. Accurate control is assured as very small changes in the controlling differential pressure produce immediate corrective action of the main valve. A solenoid control is provided to intercept the operation of the differential control and close the main valve.

The Model 43-01/643-01 includes a orifice plate with a holder that should be installed one to five pipe diameters downstream of the main valve. If the check feature option is added and a pressure reversal occurs, the downstream pressure is admitted into the main valve cover chamber and the valve closes to prevent return flow.

Schematic Diagram

Item	Description
1	Hytrol (Main Valve)
2	X58C Restriction Fitting
3	100-01 Hytrol (Reverse Flow)
4	CDHS18 Differential Control
5	CS3 Solenoid Control
6	X52E Orifice Plate Assembly

Optional Features

Item	Description
A	X46A Flow Clean Strainer
B	CK2 (Isolation Valve)
C	CV Flow Control (Closing)
D	Check Valves with Isolation Valve
H	Solenoid Drain to Atmosphere
P	X141 Pressure Gauge
S	CV Speed Control (Opening)
V	X101 Valve Position Indicator
Y	X43 "Y" Strainer

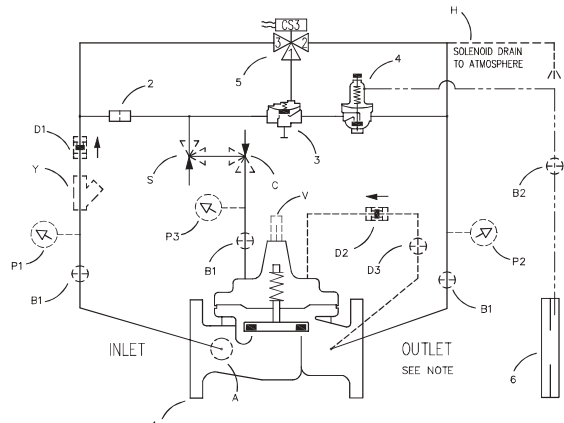

The "D" feature on a vertically installed 6" and larger valves must be horizontally installed.

Typical Applications

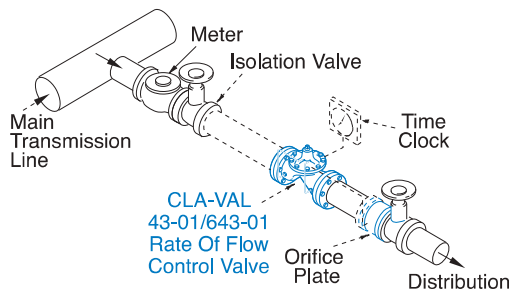

The 43-01/643-01 is typically installed where water supply to a system must be limited to a pre-set maximum flow rate at certain times of day. The valve is easily set to maintain the maximum allowable flow rate and is to open or close on an electrical signal.

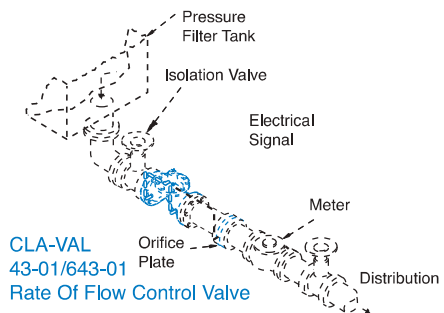

The 43-01/643-01 is typically installed as a pressure type filter effluent control valve where a constant flow rate is maintained as head loss through the filter varies. The valve opens or closes on an electrical signal.



Model 43-01 (Uses Basic Valve Model 100-01)

Pressure Ratings (Recommended Maximum Pressure - psi)

Valve Body & Cover		Pressure Class				
		Flanged		Grooved	Threaded	
Grade	Material	ANSI Standards*	150 Class	300 Class	300 Class	End‡ Details
ASTM A536	Ductile Iron	B16.42	250	400	400	400
ASTM A216-WCB	Cast Steel	B16.5	285	400	400	400
ASTM B62	Bronze	B16.24	225	400	400	400

Note: * ANSI standards are for flange dimensions only.
 Flanged valves are available faced but not drilled.
 ‡ End Details machined to ANSI B2.1 specifications.
Valves for higher pressure are available; consult factory for details

Materials

Component	Standard Material Combinations		
Body & Cover	Ductile Iron	Cast Steel	Bronze
Available Sizes	1-1/2" - 36"	1-1/2" - 16"	1-1/2" - 16"
Disc Retainer & Diaphragm Washer	Cast Iron	Cast Steel	Bronze
Trim: Disc Guide, Seat & Cover Bearing	Bronze is Standard Stainless Steel is Optional		
Disc	Buna-N® Rubber		
Diaphragm	Nylon Reinforced Buna-N® Rubber		
Stem, Nut & Spring	Stainless Steel		

For material options not listed, consult factory.
 Cla-Val manufactures valves in more than 50 different alloys.

Dimensions (In inches)

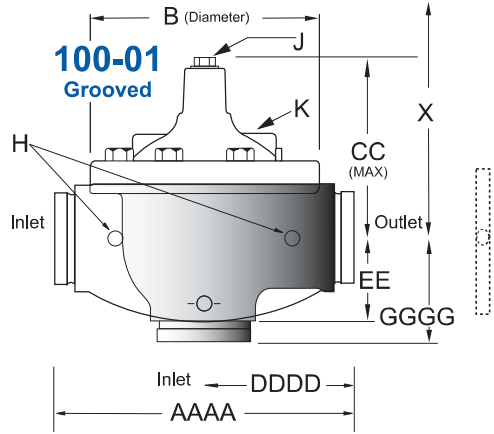
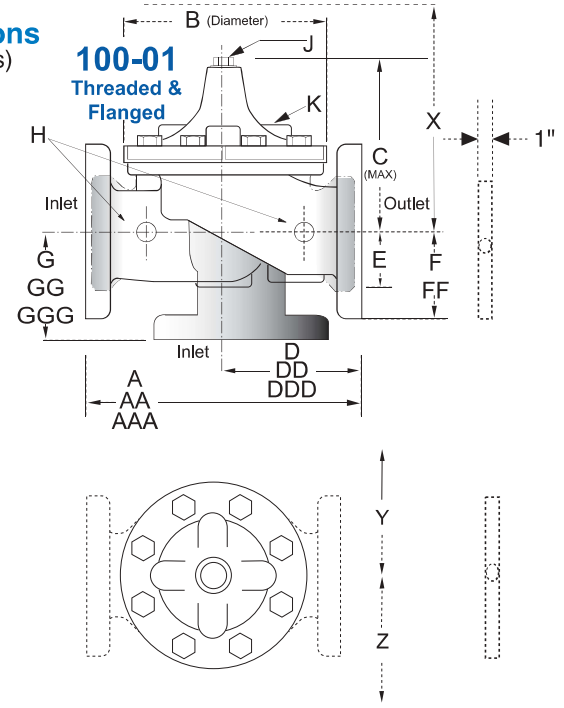

Model 43-01 Dimensions (In Inches)

Valve Size (Inches)	1 1/2	2	2 1/2	3	4	6	8	10	12	14	16	18	20	24	30	36
A Threaded	7.25	9.38	11.00	12.50	—	—	—	—	—	—	—	—	—	—	—	—
AA 150 ANSI	8.50	9.38	11.00	12.00	15.00	20.00	25.38	29.75	34.00	39.00	41.38	46.00	52.00	61.50	63.00	76.00
AAA 300 ANSI	9.00	10.00	11.62	13.25	15.62	21.00	26.38	31.12	35.50	40.50	43.50	47.64	53.62	63.24	64.50	76.00
AAAA Grooved End	8.50	9.00	11.00	12.50	15.00	20.00	25.38	—	—	—	—	—	—	—	—	—
B Dia.	5.62	6.62	8.00	9.12	11.50	15.75	20.00	23.62	28.00	32.75	35.50	41.50	45.00	53.16	56.00	66.00
C Max.	5.50	6.50	7.56	8.19	10.62	13.38	16.00	17.12	20.88	24.19	25.00	39.06	41.90	43.93	54.60	61.50
CC Max. Grooved End	4.75	5.75	6.88	7.25	9.31	12.12	14.62	—	—	—	—	—	—	—	—	—
D Threaded	3.25	4.75	5.50	6.25	—	—	—	—	—	—	—	—	—	—	—	—
DD 150 ANSI	4.00	4.75	5.50	6.00	7.50	10.00	12.69	14.88	17.00	19.50	20.81	—	—	30.75	—	—
DDD 300 ANSI	4.25	5.00	5.88	6.38	7.88	10.50	13.25	15.56	17.75	20.25	21.62	—	—	31.62	—	—
DDDD Grooved End	—	4.75	—	6.00	7.50	—	—	—	—	—	—	—	—	—	—	—
E	1.12	1.50	1.69	2.06	3.19	4.31	5.31	9.25	10.75	12.62	15.50	12.95	15.00	17.75	21.31	24.56
EE Grooved End	2.00	2.50	2.88	3.12	4.25	6.00	7.56	—	—	—	—	—	—	—	—	—
F 150 ANSI	2.50	3.00	3.50	3.75	4.50	5.50	6.75	8.00	9.50	10.50	11.75	15.00	16.50	19.25	22.50	25.60
FF 300 ANSI	3.06	3.25	3.75	4.13	5.00	6.25	7.50	8.75	10.25	11.50	12.75	15.00	16.50	19.25	24.00	25.60
G Threaded	1.88	3.25	4.00	4.50	—	—	—	—	—	—	—	—	—	—	—	—
GG 150 ANSI	4.00	3.25	4.00	4.00	5.00	6.00	8.00	8.62	13.75	14.88	15.69	—	—	22.06	—	—
GGG 300 ANSI	4.25	3.50	4.31	4.38	5.31	6.50	8.50	9.31	14.50	15.62	16.50	—	—	22.90	—	—
GGGG Grooved End	—	3.25	—	4.25	5.00	—	—	—	—	—	—	—	—	—	—	—
H NPT Body Tapping	.375	.375	.50	.50	.75	.75	1	1	1	1	1	1	1	1	2	2
J NPT Cover Center Plug	.25	.50	.50	.50	.75	.75	1	1	1.25	1.5	2	1.5	1.5	1.5	2	2
K NPT Cover Tapping	.375	.375	.50	.50	.75	.75	1	1	1	1	1	1	1	1	2	2
Stem Travel	0.4	0.6	0.7	0.8	1.1	1.7	2.3	2.8	3.4	4.0	4.5	5.1	5.63	6.75	7.5	8.5
Approx. Ship Wt. Lbs.	15	35	50	70	140	285	500	780	1165	1600	2265	2982	3900	6200	7703	11720
X Pilot System	11	13	14	15	17	29	31	33	36	40	40	43	47	68	79	85
Y Pilot System	9	9	10	11	12	20	22	24	26	29	30	32	34	39	40	45
Z Pilot System	9	9	10	11	12	20	22	24	26	29	30	32	34	39	42	47

Note: The top two flange holes on valve size 36 are threaded to 1 1/2"-6 UNC.

Model 643-01 (Uses Basic Valve Model 100-20)

Dimensions
(In inches)

Pressure Ratings (Recommended Maximum Pressure - psi)

Valve Body & Cover		Pressure Class		
		Flanged		
Grade	Material	ANSI Standards*	150 Class	300 Class
ASTM A536	Ductile Iron	B16.42	250	400
ASTM A216-WCB	Cast Steel	B16.5	285	400
ASTM B62	Bronze	B16.24	225	400

Note: * ANSI standards are for flange dimensions only.
Flanged valves are available faced but not drilled.
Valves for higher pressure are available; consult factory for details

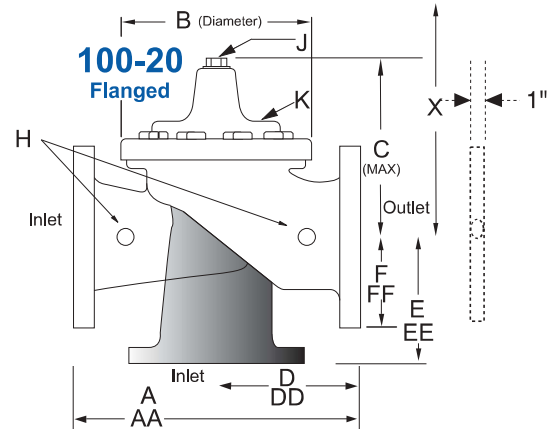

Materials

Component	Standard Material Combinations		
Body & Cover	Ductile Iron	Cast Steel	Bronze
Available Sizes	3" - 48"	3" - 16"	3" - 16"
Disc Retainer & Diaphragm Washer	Cast Iron	Cast Steel	Bronze
Trim: Disc Guide, Seat & Cover Bearing	Bronze is Standard Stainless Steel is Optional		
Disc	Buna-N® Rubber		
Diaphragm	Nylon Reinforced Buna-N® Rubber		
Stem, Nut & Spring	Stainless Steel		

For material options not listed, consult factory.
Cla-Val manufactures valves in more than 50 different alloys.

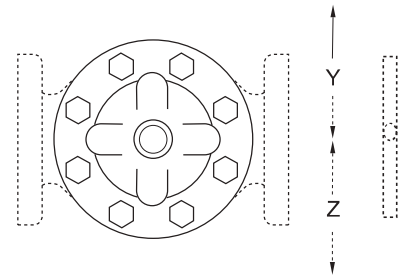

Model 643-01 Dimensions (In Inches)

Valve Size (Inches)	3	4	6	8	10	12	14	16	18	20	24	30	36	42	48
A 150 ANSI	10.25	13.88	17.75	21.38	26.00	30.00	34.25	35.00	42.12	48.00	48.00	63.25	65.00	76.00	94.50
AA 300 ANSI	11.00	14.50	18.62	22.38	27.38	31.50	35.75	36.62	43.63	49.62	49.75	63.75	67.00	76.00	94.50
B Dia.	6.62	9.12	11.50	15.75	20.00	23.62	27.47	28.00	35.44	35.44	35.44	53.19	56.00	66.00	66.00
C Max.	7.00	8.62	11.62	15.00	17.88	21.00	20.88	25.75	25.00	31.00	31.00	43.94	54.60	61.50	61.50
D 150 ANSI	—	6.94	8.88	10.69	CF*	CF*	CF*	CF*	CF*	CF*	CF*	—	—	—	—
DD 300 ANSI	—	7.25	9.38	11.19	CF*	CF*	CF*	CF*	CF*	CF*	CF*	—	—	—	—
E 150 ANSI	—	5.50	6.75	7.25	CF*	CF*	CF*	CF*	CF*	CF*	CF*	—	—	—	—
EE 300 ANSI	—	5.81	7.25	7.75	CF*	CF*	CF*	CF*	CF*	CF*	CF*	—	—	—	—
F 150 ANSI	3.75	4.50	5.50	6.75	8.00	9.50	11.00	11.75	15.88	14.56	17.00	19.88	25.50	28.00	31.50
FF 300 ANSI	4.12	5.00	6.25	7.50	8.75	10.25	11.50	12.75	15.88	16.06	19.00	22.00	27.50	28.00	31.50
H NPT Body Tapping	.375	.50	.75	.75	1	1	1	1	1	1	1	1	2	2	2
J NPT Cover Center Plug	.50	.50	.75	.75	1	1	1.25	1.25	2	2	2	2	2	2	2
K NPT Cover Tapping	.375	.50	.75	.75	1	1	1	1	1	1	1	1	2	2	2
Stem Travel	0.6	0.8	1.1	1.7	2.3	2.8	3.4	3.4	4.5	4.5	4.5	6.5	7.5	8.5	8.5
Approx. Ship Wt. Lbs.	45	85	195	330	625	900	1250	1380	1500	2551	2733	6500	8545	12450	13100
X Pilot System	13	15	27	30	33	36	36	41	40	46	55	68	79	85	86
Y Pilot System	10	11	18	20	22	24	26	26	30	30	30	39	40	45	47
Z Pilot System	10	11	18	20	22	24	26	26	30	30	30	39	42	47	49

*Consult Factory

Note: The top two flange holes on valve sizes 36 thru 48 are threaded to 1 1/2"-6 UNC.

43-01 Valve Selection	100-01 Pattern: Globe (G), Angle (A), End Connections: Threaded (T), Grooved (GR), Flanged (F) Indicate Available Sizes																
	Inches	1½	2	2½	3	4	6	8	10	12	14	16	18	20	24	30	36
	mm	40	50	65	80	100	150	200	250	300	350	400	450	500	600	750	900
Basic Valve 100-01	Pattern	G, A	G, A	G, A	G, A	G, A	G, A	G, A	G, A	G, A	G, A	G, A	G	G	G, A	G	G
	End Detail	T, F, Gr*	T, F, Gr	T, F, Gr*	T, F, Gr	F, Gr	F, Gr*	F, Gr*	F	F	F	F	F	F	F	F	F
Suggested Flow (gpm)	Maximum	125	210	300	460	800	1800	3100	4900	7000	8400	11000	14000	17000	25000	42000	50000
	Maximum Intermittent	160	260	370	580	990	2250	3900	6150	8720	10540	13700	17500	21700	31300	48000	62500
	Minimum	1	1	2	2	4	10	15	35	50	70	95	120	150	275	450	650
Suggested Flow (Liters/Sec)	Maximum	8	13	19	29	50	113	195	309	442	530	694	883	1073	1577	2650	3150
	Maximum Intermittent	10	16	23	37	62	142	246	387	549	664	863	1104	1369	1972	3028	3940
	Minimum	.03	.06	.09	0.13	0.25	0.63	0.95	2.2	3.2	4.4	6.0	7.6	9.5	17.4	28.4	41.0

100-01 Series is the full internal port Hytrol.

For Lower Flows Consult Factory

*Globe Grooved Only

643-01 Valve Selection	100-20 Pattern: Globe (G), Angle (A), End Connections: Flanged (F) Indicate Available Sizes																
	Inches	3	4	6	8	10	12	14	16	18	20	24	30	36	42	48	
	mm	80	100	150	200	250	300	350	400	450	500	600	750	900	1000	1200	
Basic Valve 100-20	Pattern	G	G, A	G, A	G, A	G	G	G	G	G	G	G	G	G	G	G	G
	End Detail	F	F	F	F	F	F	F	F	F	F	F	F	F	F	F	F
Suggested Flow (gpm)	Maximum	260	580	1025	2300	4100	6400	9230	9230	16500	16500	16500	28000	33500	33500	33500	
	Minimum	1	2	4	10	15	35	50	50	95	95	95	275	450	450	450	
Suggested Flow (Liters/Sec)	Maximum	16	37	65	145	258	403	581	581	1040	1040	1040	1764	2115	2115	2115	
	Minimum	.06	.13	.25	.63	.95	2.2	3.2	3.2	6.0	6.0	6.0	17.4	28.4	41.0	41.0	

100-20 Series is the reduced internal port size version of the 100-01 Series.

For Lower Flows Consult Factory

Pilot System Specifications

Adjustment Range

Low flow equals one-fourth maximum flow.

Temperature Range

Water: to 180°F

Electrical Ratings

24, 48, 120, 240, 480 - 60 Hz AC
6, 12, 24, 120, 240 DC

Materials

Standard Pilot System Materials

Pilot Control: Bronze ASTM B62

Trim: Stainless Steel 303

Orifice Plate: Stainless Steel 303

Rubber: Buna-N® Synthetic Rubber

Optional Pilot System Materials

Pilot systems are available with optional Aluminum, Stainless Steel or Monel materials.

When Ordering, Please Specify

1. Catalog No. 43-01 or No. 643-01
2. Valve Size
3. Pattern - Globe or Angle
4. Pressure Class
5. Threaded or Flanged
6. Trim Material
7. Adjustment Range/Orifice Bore
8. Energized or De-Energized to Open
9. Desired Options
10. When Vertically Installed

Note: Orifice plate assembly (X52E) may be attached to the main valve outlet flange, however, better control is obtained if it is located one to five pipe diameters downstream. Orifice plate sensing connection should be located in the pipeline on the side of the orifice plate assembly. The orifice plate assembly should not be mounted directly to a butterfly valve. See E-X52E Data Sheet for Orifice Bore adjustment range.

A-6 Pipeline Sizing Justification

Title: Conestoga River Pipe Size Calculation

Project Name: Atlantic Sunrise
 Client: Transcontinental Gas Pipe Line Company LLC

Prepare By: LMH
 Checked By: GH

Date: 7/21/2016
 Date: 7/21/2016

Design Flow Rate	500	gpm	
Length ¹	502	ft	
Elevation at Start ¹	187	ft MSL	
Elevation at Pump	194	ft MSL	
Elevation at End ¹	200	ft MSL	
Backpressure at Discharge	43	psig	(NOTE: to account for minor losses; throttle discharge valve as required)
Hazen-Williams Coefficient	140		
Suction Pipe Length	100	ft	

¹ design basis to transfer water to pipeline, additional equipment to be used by hydrotest contractor.

Estimate Pipe Size based on velocity

Maintain Velocity at needed area 15.0 ft/sec or less (temporary piping)
 0.07 sf or a dia. = 3.7 inches I.D.

Pressure Drop Calculations

Use: Hazen-Williams Eq.:

$$h_f = \frac{0.2083 * \left(\frac{100}{C}\right)^{1.85} * Q^{1.85} * L}{100 * D^{4.8655}}$$

Flow rate, gpm	(gpm)	500	500	500	
Pipe Size	(inch)	4	6	8	
Outer Diameter	(inch)	4.5	6.625	8.625	
DR rating	-	13.5	13.5	13.5	
Diameter (D)*	(inch)	3.79	5.58	7.27	
Length (L)	(feet)	502	502	100	
Friction Head Loss (dH)	(feet)	84.1	12.8	1.7	
Total Head loss	(feet)	196.02	124.71	21.6	NPSHa > NPSHr =
	(psi)	85	54		10.0 ft

* - includes 6% safety factor on wall thickness

Horsepower Required

Determine Theoretical Hp req'd: HP	25	16
Pump Efficiency (est)	65%	65%
Motor Efficiency (est)	85%	85%
Motor Horsepower (est) HP	45	29

Design Considerations for Hydrotest

CPL Max Elevation: 0 ft MSL Water will be trucked to fill location.
 Max Static Head: #N/A ft

LOOKUP TABLE: DIAMETER	
2	2.375
3	3.5
4	4.5
6	6.625
8	8.625
10	10.75
12	12.75
14	14
16	16
18	18
20	20
22	22
24	24

DR	MAWP
7.3	317
9	250
11	200
13.5	160
17	125
21	100
26	80
32.5	63



Search Google
Parcel Search (APN)
Search
ex: 15213
Get Directions History

Places
My Places
Temporary Places
Transfer Pathway

Layers Earth Gallery

- Primary Database
- Earth Pro (US)
- Voyager
- Borders and Labels
- Places
- Photos
- Roads
- 3D Buildings
- Ocean
- Weather
- Gallery
- Global Awareness
- More
- Terrain

Imagery Date: 4/24/2013 1992 39°57'42.61" N 76°21'50.91" W elev 201 ft Eye alt 2535 ft

Graph: Min. Avg. Max Elevation: 187, 205, 235 ft
Range Totals: Distance: 515 ft Elev Gain/Loss: 67.5 ft, -53.7 ft Max Slope: 90.8%, -77.4% Avg Slope: 2.1%, -76.6%



A-7 Flow Meter Specification



APPLICATIONS

- Irrigation
- Chemigation
- Agricultural automation
- Well usage monitoring
- Dairy Lagoons

FEATURES

- Simple as a mechanical meter
- No moving parts
- Minimal straight pipe required
- Battery power standard; External power optional
- Solar compatible
- Built-in rate & total indicator
- Built-in pulse output for data-logging or telemetry
- Tamper-evident seal

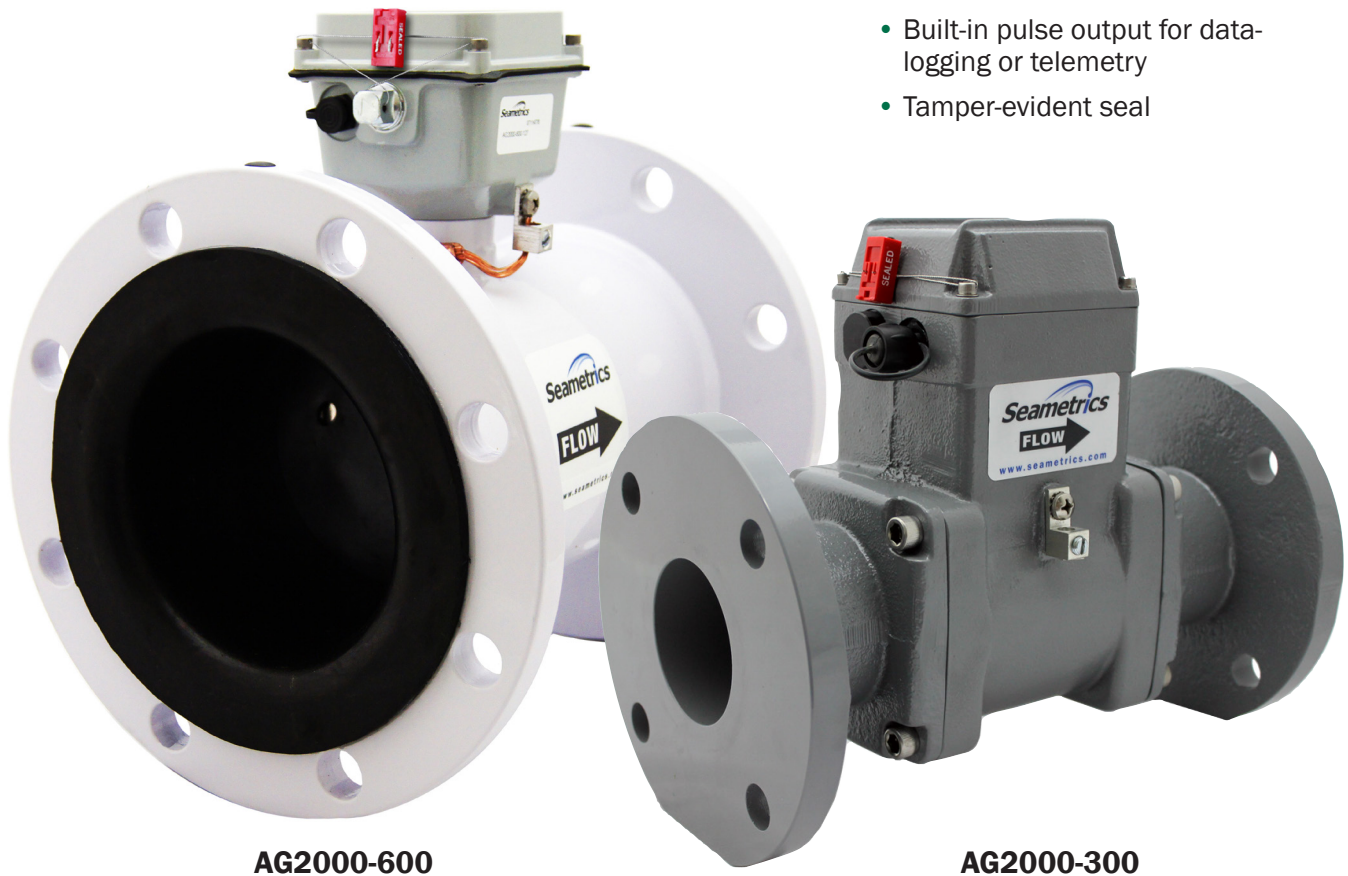

AG2000-600

AG2000-300

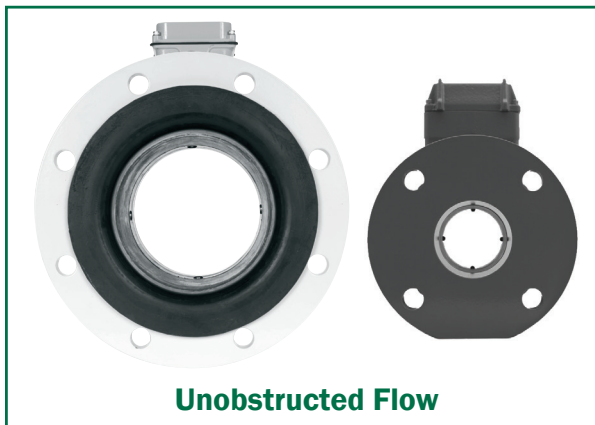

Unobstructed Flow

Seametrics' series of standard and IP68 (submersible) flanged magmeters.

Available in sizes from 3" up to 12".

GENERAL INFORMATION

The AG2000 is a spool-type electromagnetic flowmeter for use in irrigation applications in 3" to 12" pipe. With no moving parts, these meters provide unobstructed flow and are resistant to wear from debris found in ground or surface water. Little maintenance is required because there are no bearings to wear out or propellers to stop turning. Minimal straight pipe requirements allow AG2000 meters to be used in piping configurations where there is little space between the meter and an elbow.

The standard AG2000 is battery powered. Where an external power source is available, the AG2000 can be optionally converted to 8-32 Vdc, with the batteries then serving as back-up to maintain continuous operation in case of power failure. This configuration will prolong battery life indefinitely.

An IP68 version (-168 option) is available for burial or applications where the meter may be under water up to a depth of 3 meters for prolonged periods of time.

The meter comes with built-in pulse output (requires optional cable) for data logging or telemetry. Several pulse rates are available. An internal data logger is also available for secure flow logging (-127 option). A Seametrics FT415W or FT420W display can be added if remote rate/total reading is desired, or an AO55W if a (4-20 mA) analog signal is required. (High-frequency pulse rate is required for use with most Seametrics controllers.)

The AG2000 is secured with a seal wire to protect against unauthorized access. The seal can be broken by an authorized agent, to change units of measure, replace the battery pack, or to field-install an optional power/output cable. The cable can be factory or field-installed where external power is available and/or pulse output is needed. An accessory weather guard is available for additional protection in outdoor applications.

For chemigation applications, the chemical injection point must be placed downstream of the meter **OR** far enough upstream for **complete mixing** to occur before the flow reaches the meter. (See tech bulletin on Seametrics' website, www.seametrics.com).

FEATURES

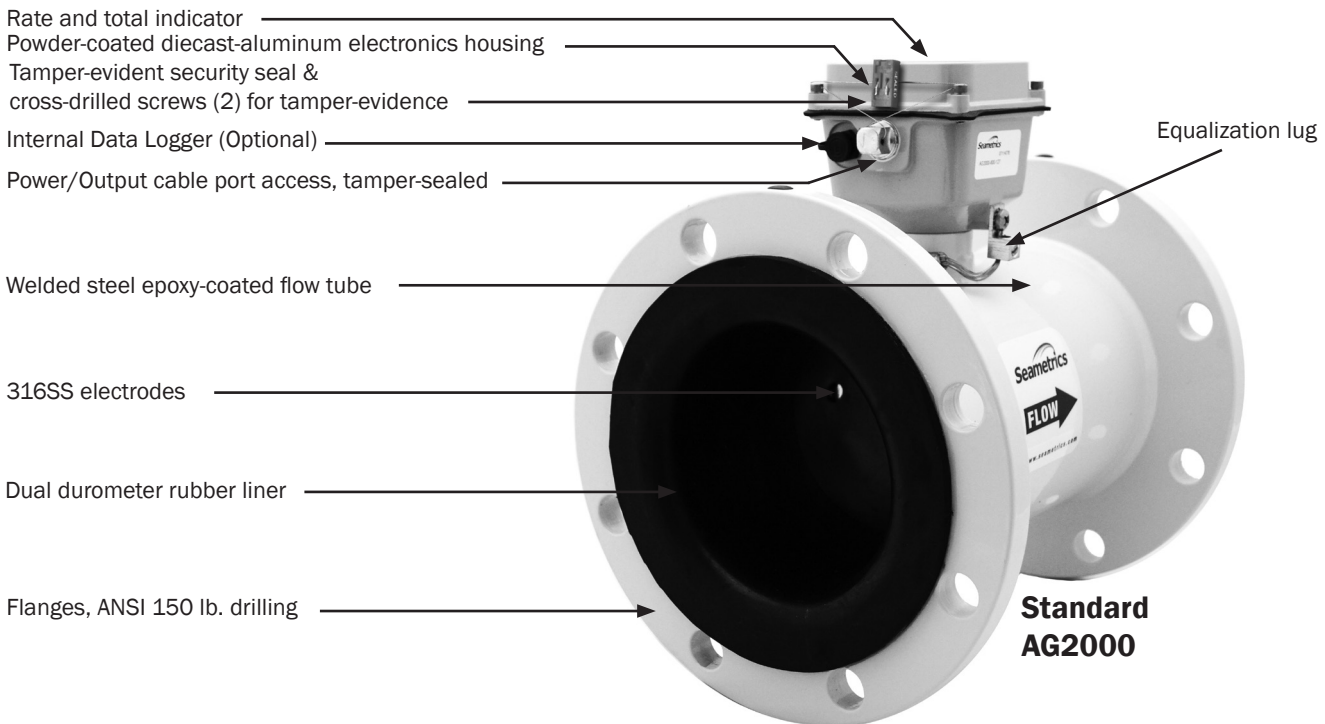

**Standard
AG2000**

FEATURES Continued

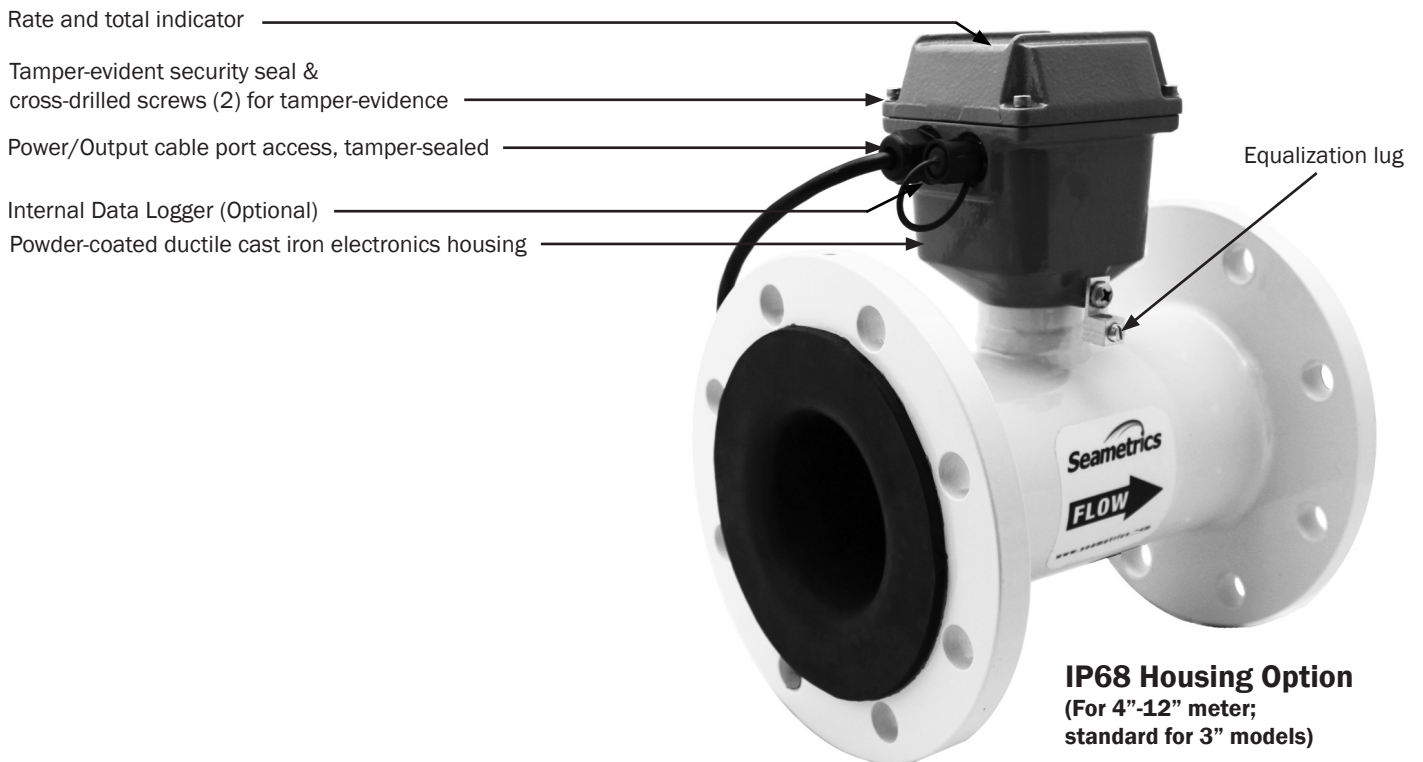
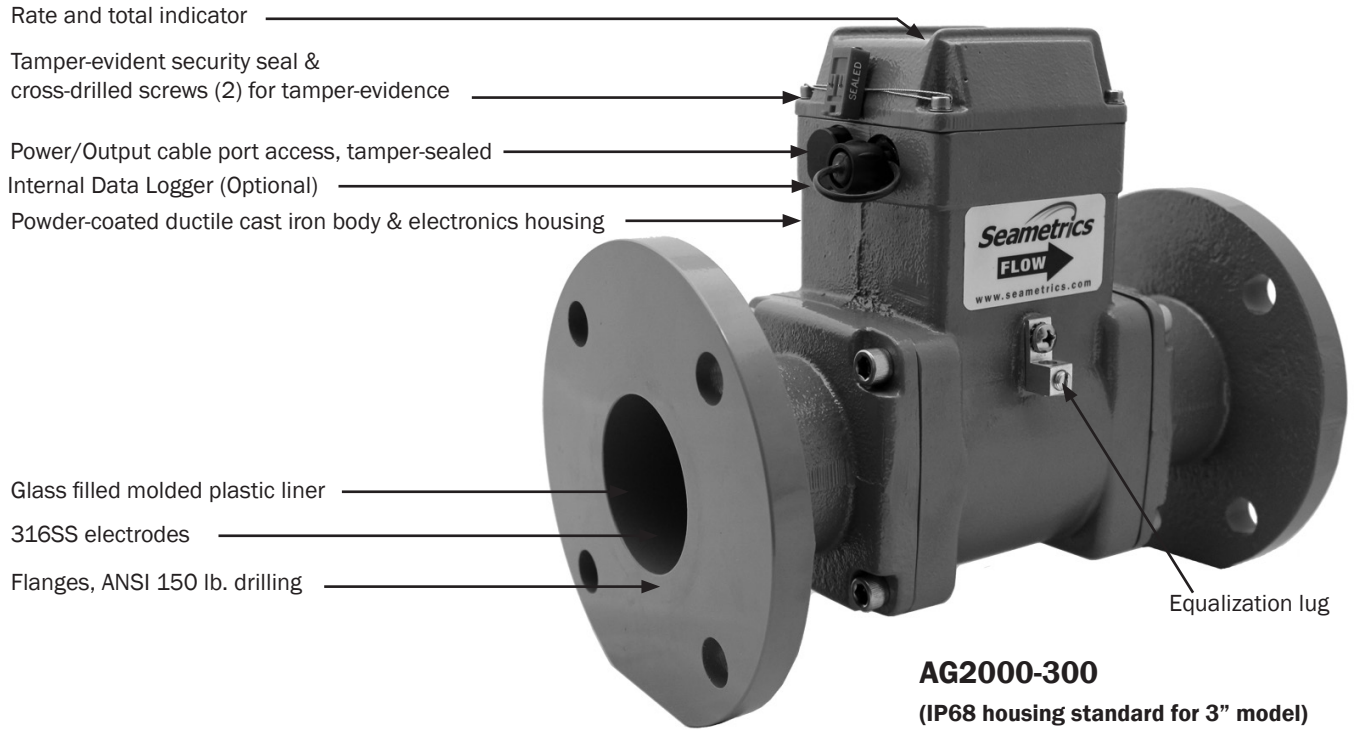



AG2000 Irrigation Magmeter

SPECIFICATIONS*

Pipe Sizes	3", 4", 6", 8", 10", 12"						
Fittings	ANSI 150 lb. drilling						
Pressure	150 psi (10.3 bar) working pressure						
Temperature	Operating	10° to 130° F (-12° to 54° C)					
	Non-Operating	-40° to 158° F (-40° to 70° C)					
Accuracy	+/- 1% of reading for flow between 10% to 100% of max flow						
	+/- 2% of reading for flow from cutoff to 10% of max flow						
Materials	Body (3" Only)	Ductile cast iron, powder coated w/NSF61 listed epoxy powder					
	Body (4"-12")	Welded steel, epoxy-coated					
	Liner (3" Only)	Noryl®					
	Liner (4"-12")	Santoprene/Polypropylene					
	Electronics Housing	Diecast aluminum, powder-coated (non-IP68)			Ductile Cast Iron (IP68)		
	Electrodes	316 stainless steel					
	O-ring (3" Only)	EPDM					
Display	Rate					Total	
	Digits	5				8	
	Units	Gallon/Minute, Liter/Minute, Cubic Feet/Minute, Cubic Meter/Hour, Gallons/Sec, Liter/Second, Cubic Feet/ Sec, Miner's Inch, Cubic Meter/Min				Gallon, Gallon x 1000, Liter, Liter x 1000, Mega Liter, Cubic Meters, Cubic Meter x 1000, Acre Feet, Cubic Feet, Cubic Feet x 1000, Million Gallon, Miner's Inch Day, Acre Inch	
Power	1 battery pack that contains 2 Lithium 3.6V "D" batteries, replaceable. Standard battery life 2.5 years 5 years with extended battery life (EBL) option With external power option (uses 8-32 Vdc, 30 mA), Lithium batteries serve as backup in power failure (10 year life)						
Pulse Output (with optional cable)	Signal	Current sinking pulse, opto-isolated, 30 Vdc at 10 mA max					
	Pulse Rates	High Frequency; 10 units/pulse; 100 units/pulse; 1000 units/pulse					
	High Frequency (pulse/gal)	3"	4"	6"	8"	10"	12"
		25.228	16.362	6.307	3.344	2.15	1.530
Conductivity	>20 microSiemens/cm						
Empty Pipe Detection	Hardware/software, conductivity-based						
Environmental	NEMA 4X Standard (IP68 Option)						

*Specifications subject to change. Please consult our website for the most current data (www.seametrics.com).

**Extended battery life option is standard on all IP68 meters.

OUTPUT CAPABILITIES

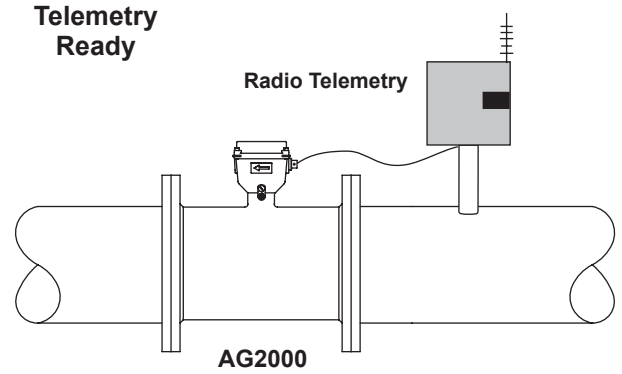
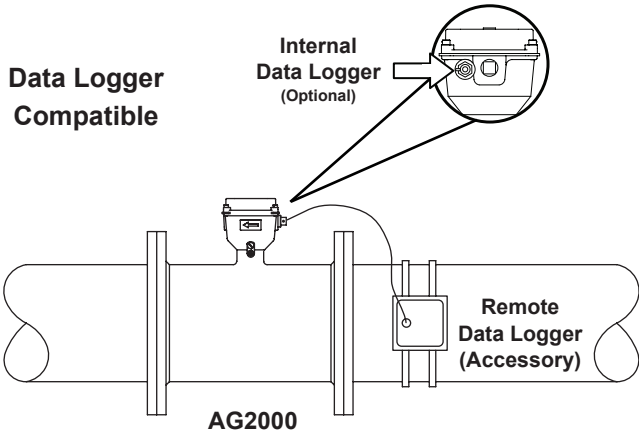

DIMENSIONS

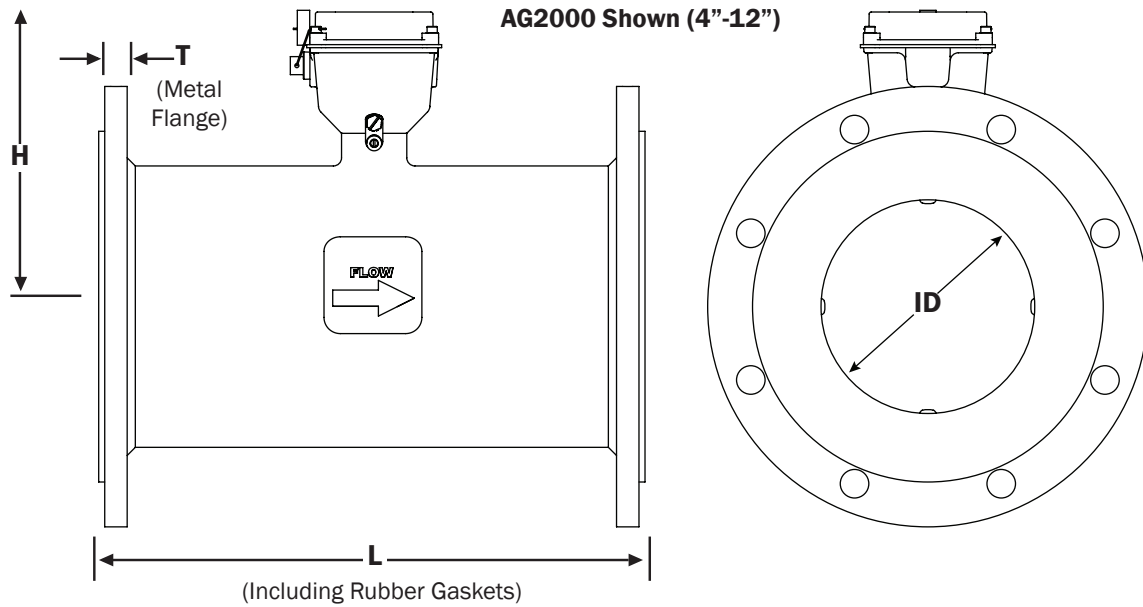

AG2000 (Standard Housing)

Standard AG2000 Meter Size	L		H		T		ID		Shipping Weight Standard	
	inch	mm	inch	mm	inch	mm	inch	mm	pounds	Kg
4"	10.24	260	7.0	178	.62	20.9	3.12	79.25	32	15
6"	12.27	312	8.1	206	.69	23.3	5.05	128.27	47	21
8"	14.24	362	9.1	231	.69	23.3	6.44	163.58	69	31
10"	18.18	462	10.1	257	.69	23.3	8.61	218.69	125	57
12"	19.68	500	11.1	282	.81	20.6	10.55	267.97	145	66
Flanges	Standard ANSI 150 lb. drilling								Cable (AG2000) 1 lb.	

DIMENSIONS

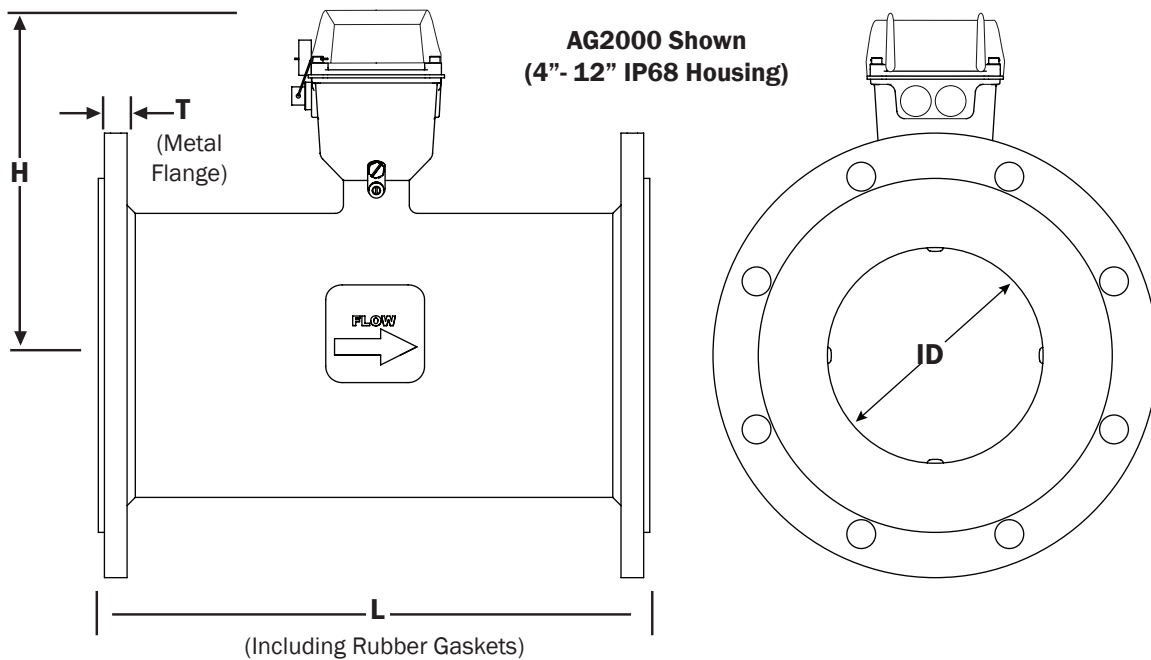
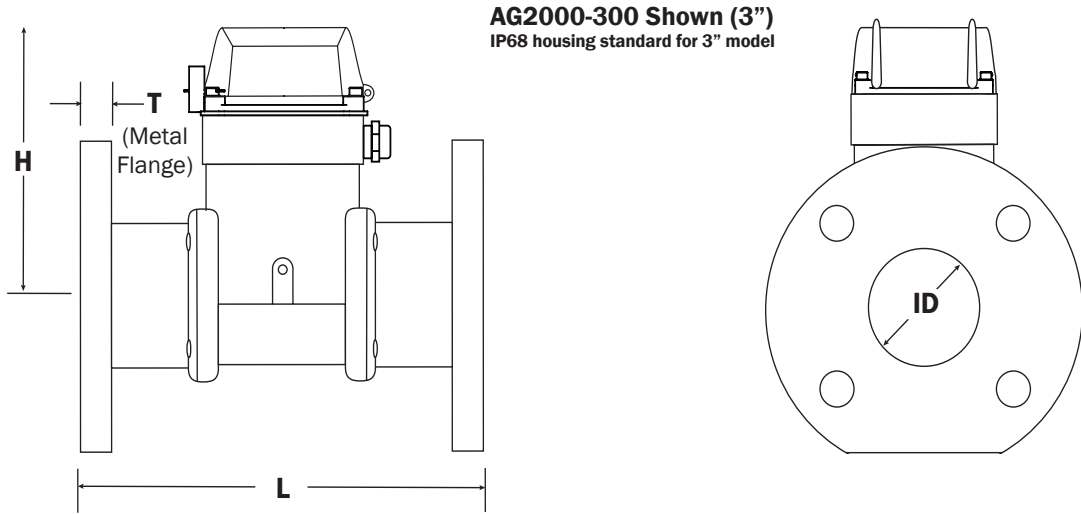

AG2000 with IP68 Housing (-168 option)

IP68 AG2000 Meter Size	L		H		T		ID		Shipping Weight IP68 Version	
	inch	mm	inch	mm	inch	mm	inch	mm	pounds	Kg
3"	12.0	305	6.80	173	.68	17.3	2.60	66.04	41	19
4"	10.24	260	8.12	206	.62	20.9	3.12	79.25	35	16
6"	12.27	312	9.22	234	.69	23.3	5.05	128.27	50	23
8"	14.24	362	10.22	260	.69	23.3	6.44	163.58	72	33
10"	18.18	462	11.22	285	.69	23.3	8.61	218.69	128	58
12"	19.68	500	12.28	312	.81	20.6	10.55	267.97	148	67

Flanges Standard ANSI 150 lb. drilling

Cable (AG2000) 1 lb.

STRAIGHT PIPE RECOMMENDATIONS

(X = pipe diameter)

*Minimal straight pipe
required between elbows.
For other piping configurations,
consult factory.*

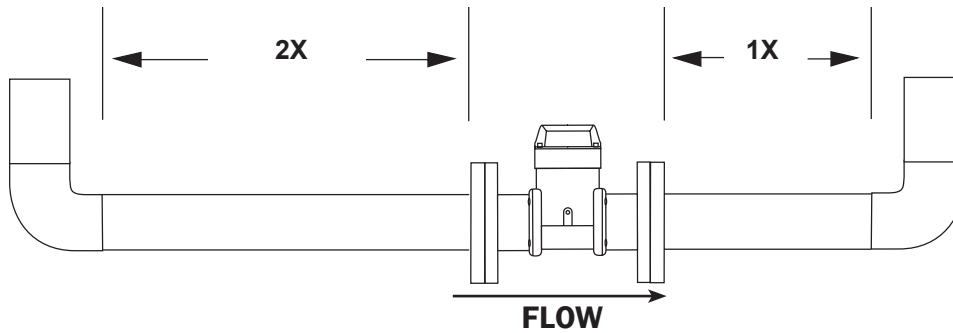

(X = pipe diameter)

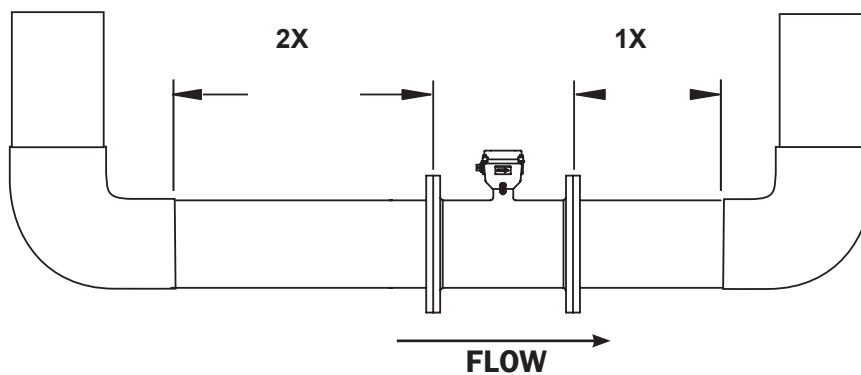

FLOW RANGE (3" - 12")

Meter Size	3"		4"		6"		8"		10"		12"	
	Gal/Min	Liter/Sec	Gal/Min	Liter/Sec	Gal/Min	Liter/Sec	Gal/Min	Liter/Sec	Gal/Min	Liter/Sec	Gal/Min	Liter/Sec
Minimum	7.5	.47	12	.75	32	2	60	3.8	95	6	130	8.2
Maximum	700	44.2	1,000	63	2,400	151.4	4,400	277.6	7,000	441.6	10,000	630.9

HOW TO ORDER

MODEL	SIZE	OPTIONS	PULSE RATE (With Option -11)	UNITS
AG2000	3" = -300* 4" = -400 6" = -600 8" = -800 10" = -1000 12" = -1200	Factory Installed Power/ Output Cable: 6m (20 ft) = -11/6 15m (50 ft) = -11/15 30m (100 ft) = -11/30 Factory Installed IP68 Power/Output Cable: 6m (20 ft) = -11/6S 15m (50 ft) = -11/15S 30m (100 ft) = -11/30S Internal Data Logger = -127 Serial Output = -131 IP68 Submersible = -168 Extend. Battery Life ¹ = -178	10 Units*/Pulse = -PxX 100 Units*/Pulse = -PxH 1000 Units*/Pulse = -PxK High Frequency** = -HF	Gal/Min = GPM Gal = G Liter/Min = LPM Gal x 1000 = GT Cu Ft/Min = CFM Liter = L Cu Meter/Hr = CMH Liter x 1000 = LT Gal/Sec = GPS Mega Liters = ML Liters/Sec = LPS Cubic Meters = CM Cu Ft/Sec = CFS Cu Met x 1000 = CMT Miner's In** = MI Acre Feet = AF Cu Met/Min = CMM Cubic Feet = CF Cu Feet x 1000 = CFT Million Gal = MG Miner's Inch Day = MID Acre Inch = AI
	*-300 available in IP68 only	¹ Extended battery life is standard on all IP68 meters	*Units = Gal or Liter depending on Rate/Total unit selection **High Frequency pulse rate will shorten battery life	Consult factory for additional units Any rate selection can be combined with any total selection ** 1 Miner's Inch = 1.2 CFM

ACCESSORIES

Remote 4-20 mA (analog) signal = **AO55W**

Remote Rate and Total Indicator (Battery) = **FT415W***

Remote Rate and Total Indicator (Powered) = **FT420W***

Remote Data Logger = **DL76W**

Dual Power Supply, 115 Vac, 12/24 Vdc = **PC42**
(Use with High Frequency pulse rate)

Replacement Battery Pack = 100889

Weather Guard = **100961**

Post-Factory 20-ft. Power/Output Cable
(Standard Housing Only) = **DC30**

Post-Factory 50-ft. Power/Output Cable
(Standard Housing Only) = **DC35**

Post-Factory 20-ft. Power/Output Cable
(IP68 Housing Only) = **DC30S**

Post-Factory 50-ft. Power/Output Cable
(IP68 Housing Only) = **DC35S**

Grounding Rings
(not needed for most applications):

3" = **102157**

4" = **100876**

6" = **100877**

8" = **100878**

10" = **100879**

12" = **103288**

*Consult customer service to determine the appropriate indicator based on the distance it will be installed from the meter.

CONTACT YOUR SUPPLIER

A-8 Plans, Details, and Maps

Notes:

- 1) Topographic map provided by ESRI's ArcGIS Online USA Topo Maps map service (© 2013 National Geographic Society, i-cubed).
- 2) Quadrangles displayed are Conestoga and Safe Harbor.

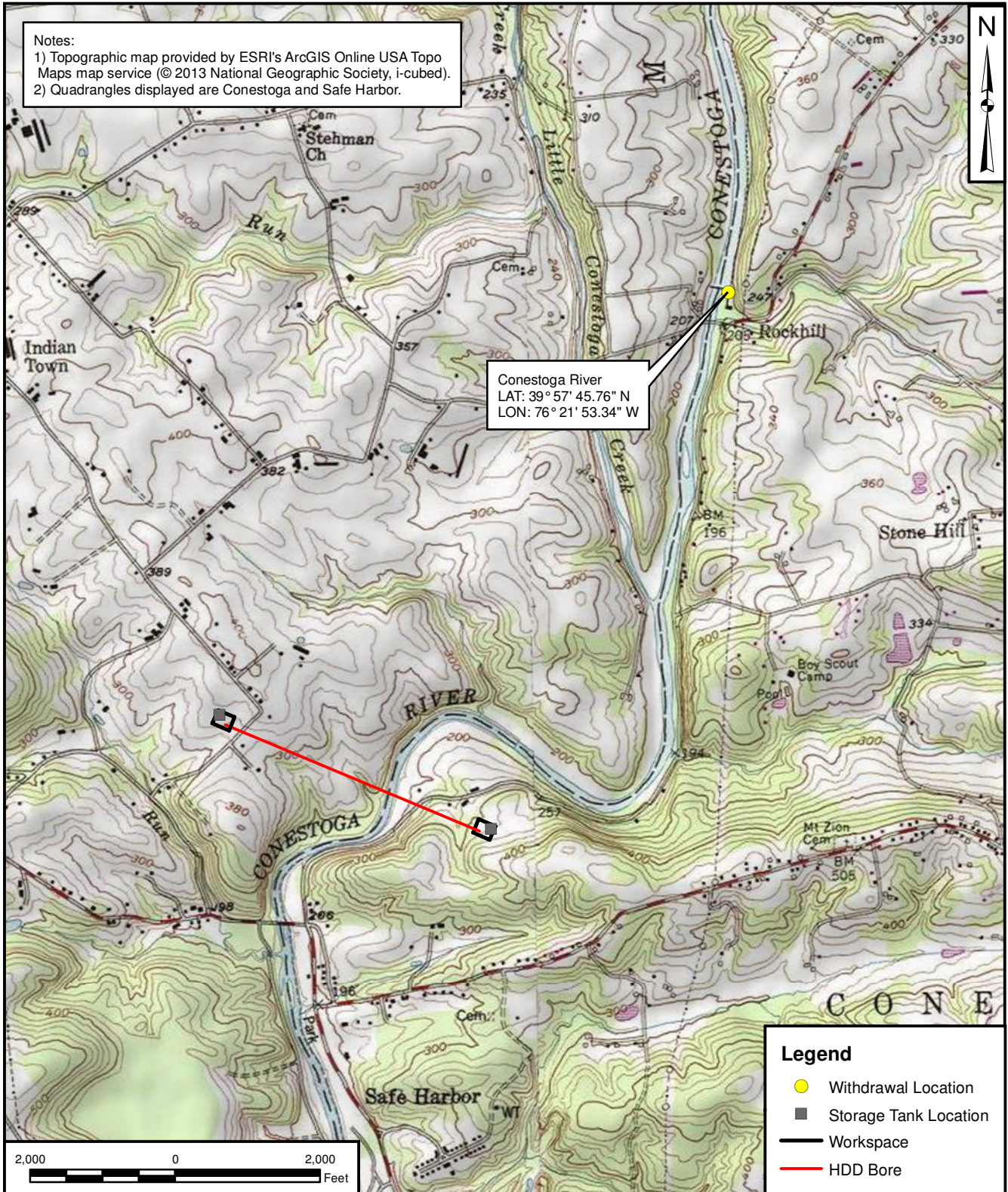

Legend

- Withdrawal Location
- Storage Tank Location
- Workspace
- HDD Bore



USGS LOCATION MAP
 TRANSCONTINENTAL GAS PIPE LINE COMPANY, LLC
 CONESTOGA RIVER
 CONESTOGA TOWNSHIP
 LANCASTER COUNTY, PA

DRAWN BY: J. HERNING 11/03/15
 CHECKED BY: L. HERRING 12/16/15
 APPROVED BY:

CONTRACT NUMBER: 212C-PC-00282

FIGURE NUMBER **8-1**

REV **0**

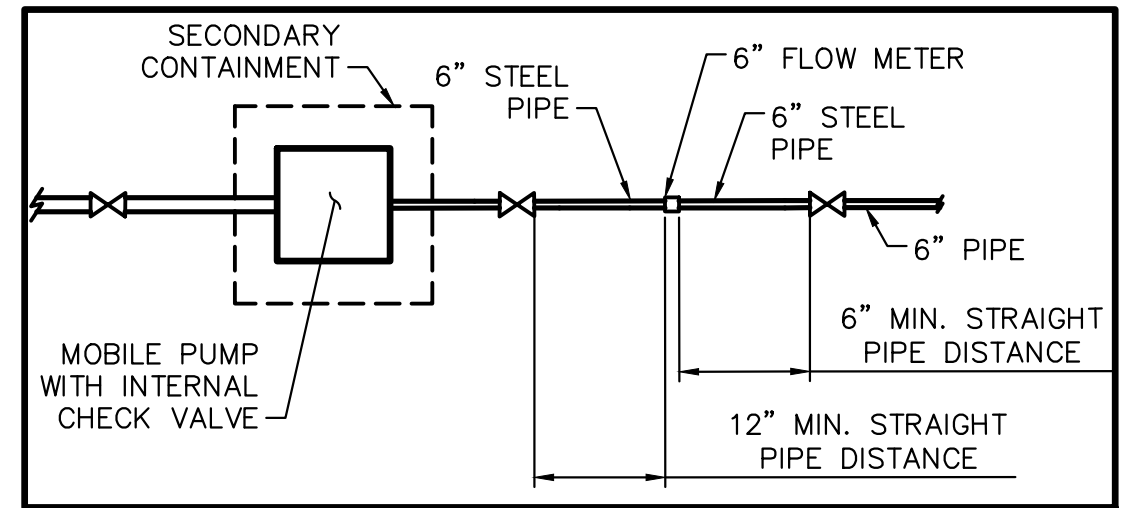
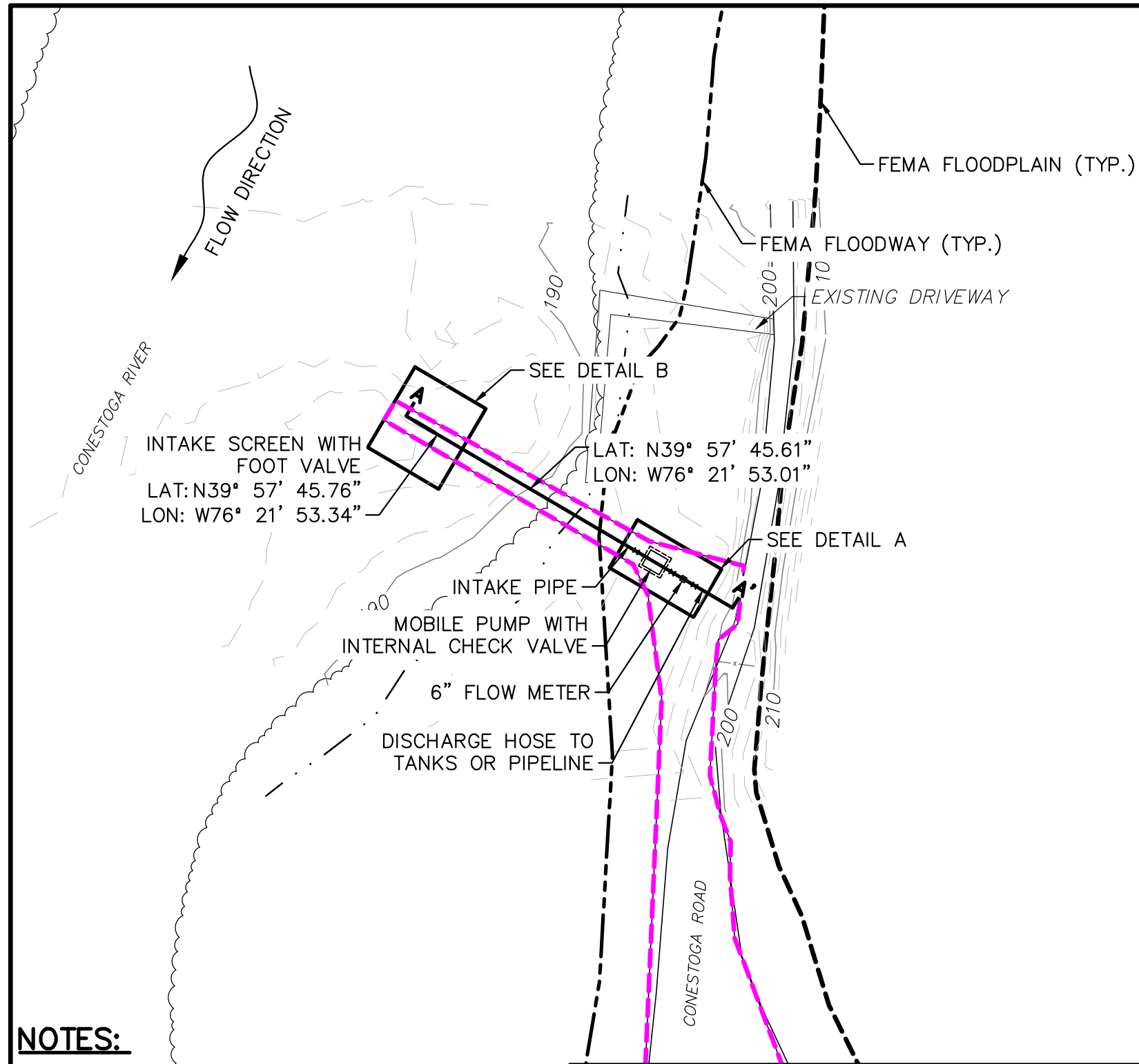

**PUMP & FLOW METER
DETAIL A**
NOT TO SCALE

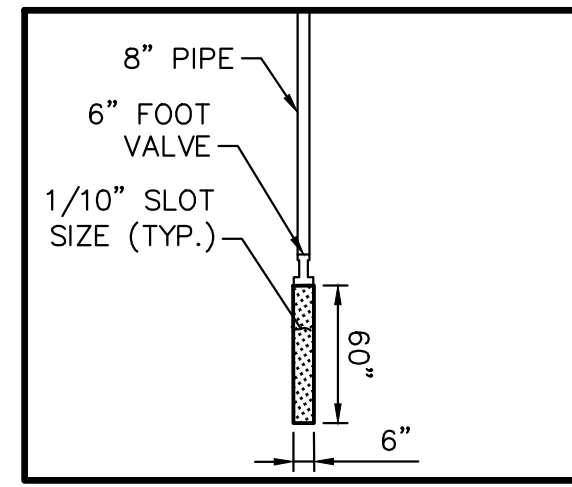

**SHALLOW WATER INTAKE
DETAIL B**
NOT TO SCALE

LEGEND

- - - - - LIMIT OF DISTURBANCE
- - - - - 1320 EXISTING 10' CONTOUR
- - - - - EXISTING 2' CONTOUR
- — — — — EXISTING ROAD
- — — — — EXISTING DRIVEWAY
- ~ ~ ~ ~ ~ EXISTING TREE LINE
- · - · - · - STREAM TOP OF BANK
- - - - - FEMA FLOODWAY
- - - - - FEMA FLOODPLAIN
- ⊗ VALVE

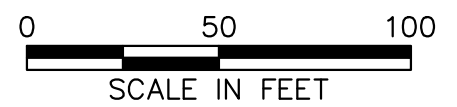

NOTES:

1. SURVEY DATUM:
HORIZONTAL: PA STATE PLANE NAD83
VERTICAL: NAVD88
2. HYDROTEST FILL LOCATION OFFSITE
3. STORAGE TANK AREA OFFSITE
4. PLACEMENT OF HYDROSTATIC WATER
WITHDRAWAL EQUIPMENT WILL HAVE NO EARTH
DISTURBANCE AND IS TEMPORARY IN NATURE.



WWW.TETRATECH.COM

661 ANDERSEN DRIVE - FOSTER PLAZA 7
PITTSBURGH, PA 15220
T: (412) 921-7090 | F: (412) 921-4040

TRANSCONTINENTAL GAS PIPE LINE COMPANY LLC
CONESTOGA RIVER PRIMARY, CONESTOGA TWP, LANCASTER CO.

SITE PLAN

DATE:	08/12/16
PROJECT NO.:	212C-PB-00282
DESIGNED BY:	RD
DRAWN BY:	NN
CHECKED BY:	CR
SHEET:	1 OF 2

COPYRIGHT TETRA TECH INC.

FIGURE 8-2

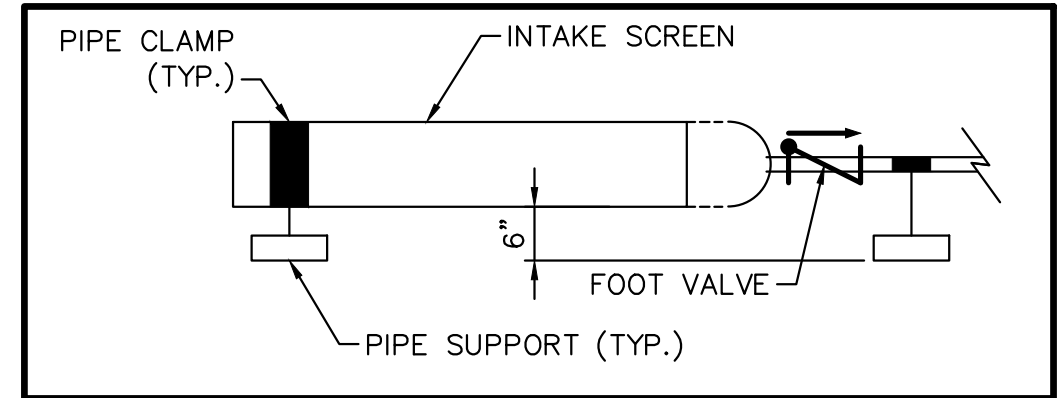

INTAKE PROFILE
DETAIL C
 NOT TO SCALE

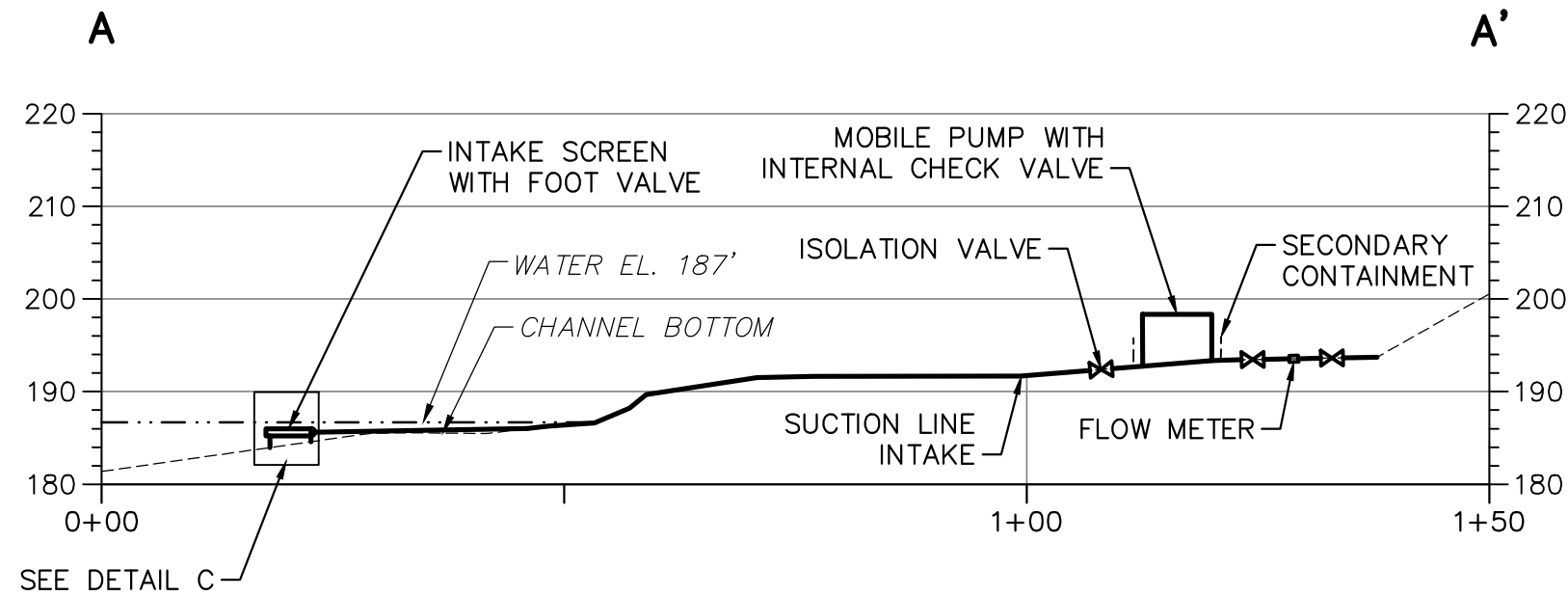

CROSS-SECTION A-A'

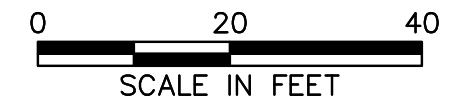

NOTES:

SURVEY DATUM:
 HORIZONTAL: PA STATE PLANE NAD83
 VERTICAL: NAVD88



WWW.TETRATECH.COM

661 ANDERSEN DRIVE - FOSTER PLAZA 7
 PITTSBURGH, PA 15220
 T: (412) 921-7090 | F: (412) 921-4040

TRANSCONTINENTAL GAS PIPE LINE COMPANY LLC
 CONESTOGA RIVER PRIMARY, CONESTOGA TWP, LANCASTER CO.

CROSS-SECTION OF INTAKE SYSTEM

DATE:	12/1/15
PROJECT NO.:	212C-PB-00282
DESIGNED BY:	RD
DRAWN BY:	NN
CHECKED BY:	CR
SHEET:	2 OF 2

COPYRIGHT TETRA TECH INC.
FIGURE 8-3

A-9 Field Photographs



07:12 23-10-2015

Lat: 39° 57' 45.42" N Lon: 76° 21' 53.18" W

Conestoga River Withdrawal Point