

Erosion and Sediment Control Plan

Pennsylvania Pipeline Project Ebensburg Pump Station

November 2016



Prepared for:

Sunoco Pipeline, L.P.
525 Fritztown Road
Sinking Spring, PA 19608
610-670-3200



Prepared by:

Tetra Tech, Inc.
661 Andersen Drive
Pittsburgh, PA 15220



TABLE OF CONTENTS

Section	Page
1.0 INTRODUCTION	1-1
1.1 PROJECT DESCRIPTION	1-1
1.2 APPROACH AND OVERVIEW	2-1
2.0 SITE DESCRIPTION	2-1
2.1 TOPOGRAPHY	2-1
2.2 GEOLOGY AND SOILS	2-1
2.3 SURFACE WATER HYDROLOGY	2-4
3.0 EROSION AND SEDIMENT CONTROL PRACTICES	3-1
3.1 CONSTRUCTION SEQUENCE	3-1
3.2 BEST MANAGEMENT PRACTICES	3-2
3.3 DESCRIPTION OF BMPs	3-2
3.4 PRIMARY CONSTRUCTION ACTIVITIES	3-5
3.5 MAINTENANCE AND INSPECTION PROCEDURES.....	3-11
3.6 ANTIDEGRADATION.....	3-14
3.7 SITE RESTORATION	3-14
4.0 REFERENCES	4-1

LIST OF ATTACHMENTS

- 1 USGS Location Map
- 2 E&S Plan Sheets
- 3 Construction Details
- 4 Soils Map, Soils Description, Limit of Soils Table, Geologic Formations Map

LIST OF ACRONYMS

ACRONYM	MEANING
ABACT	Antidegradation Best Available Combination of Technologies
BMPs	Best management practices
CFS	Compost filter socks
CWF	Cold water fisheries
E&S	Erosion and sediment
E&SCP	Erosion and sediment control plan
ESCGP-2	Erosion and Sediment Control General Permit 2
EV	Exceptional value
FEMA	Federal Emergency Management Agency
HQ	High quality
LOD	Limit of disturbance
PADEP	Pennsylvania Department of Environmental Protection
PCSM	Post-Construction Stormwater Management
PPP	Pennsylvania Pipeline Project
ROW	Right-of-way
Tt	Tetra Tech, Inc.
UNT	Unnamed tributary
USGS	United States Geological Survey

1.0 INTRODUCTION

Tetra Tech, Inc. (Tt) has prepared this Erosion & Sediment Control Plan (E&SCP) for the activities associated with the installation of the Sunoco Pipeline, L.P. (Sunoco) – Pennsylvania Pipeline Project (PPP) – Ebensburg Pump Station (Project). The Project is located in Cambria Township, Cambria County, Pennsylvania (PA). A site location map is provided in Attachment 1. This E&SCP, if properly implemented, will provide for effective E&SCs throughout construction. Work will be performed within the limit(s) of disturbance (LOD) as depicted on the E&SCP drawing.

1.1 PROJECT DESCRIPTION

The Project involves construction at the Ebensburg Pump Station, which will be connected to the PPP twenty-inch diameter transmission pipeline. Construction activities will involve installation of a rock construction entrance, pump station installation, and site restoration. Pump station installation will include a power distribution center, enclosed flare, knock out tank, pump motor, cable tray, pipe rack, light pole, and pipe supports. The proposed Ebensburg Pump Station will be constructed within a LOD of approximately 4.44 acres in Cambria County.

Past and present land use of the project area and surrounding area is residential and meadowland. Future land use will be a maintained gravel pad which the pump station will sit on. Relevant topographic features including streams, streets, pipelines, structures, utility lines, fences, paving and other significant items along the pump station LOD are indicated on the plans, where applicable.

1.2 APPROACH AND OVERVIEW

This E&SCP was developed using Pennsylvania Department of Environmental Protection (PADEP) guidance documents and sound engineering judgment. When implemented properly, the E&SC practices identified herein will minimize uncontrolled surface water runoff from disturbed areas and minimize the migration of construction-generated sediment. The following general principals apply:

- Planning. Site topography, soil types, and potential effects of construction-related activities on E&S migration have been considered in developing this E&SCP. Areas of steep, erodible slopes and/or erodible soils, if encountered during construction activities, will not be disturbed without instituting proper engineering controls to minimize these concerns.
- Minimize Land Disturbance. To the extent possible and practical, disturbed areas and the duration of exposure to erosion elements will be minimized. Clearing of vegetation will be limited to only those areas of the site to be disturbed at a given time. Existing vegetation will be retained and protected to the extent possible.
- Installation of E&SCs. E&SC best management practices (BMPs) will be constructed, stabilized, and functional before earth disturbance activities begin within the tributary areas of those BMPs.

- Maintenance of E&SCs. Until the site is stabilized, E&SCs will be properly maintained. Maintenance will entail inspections of E&SC features on a weekly basis and after runoff events. Preventative and corrective maintenance work, including clean out, repair, replacement, regrading, reseeding, and mulching will be performed as soon as practical. If E&SCs fail to perform as expected, replacements or modifications of those installed will be required.
- Stabilization of Disturbed Areas. If a cessation of earth disturbance activities lasts 4 days or longer, the site will be immediately seeded, mulched, or otherwise protected from accelerated E&S. BMPs will remain in place and be maintained until permanent stabilization is achieved. Disturbed areas will be stabilized as soon as is practical, including areas disturbed during the removal of BMPs. Temporary and permanent vegetation, mulch, gravel cover, repaving or a combination of these measures, will be employed immediately following the completion of backfilling and final grading activities.
- Floodplain. (See 25 PA Code §105.1) - A floodplain is the land adjoining a river or stream that has been or may be expected to be inundated by flood waters in a 100-year frequency flood. Unless otherwise specified, the boundary of the floodplain is as indicated on maps and flood insurance studies provided by Federal Emergency Management Agency (FEMA). In an area where no FEMA maps or studies have defined the boundary of the 100-year frequency floodplain, it is assumed absent evidence to the contrary, that the floodplain extends from (1) any perennial stream to 100 feet horizontally from the top of the bank, and (2) from any intermittent stream to 50 feet horizontally from the top of the bank of such intermittent stream.
- Floodway. The floodway is the channel of the watercourse and portions of the adjoining floodplains which are reasonably required to carry and discharge the 100-year frequency flood. Unless otherwise specified, the boundary of the floodway is as indicated on maps and flood insurance studies provided by FEMA. In an area where FEMA maps or studies have not been defined the boundary of the 100-year frequency floodway, it is assumed, absent evidence to the contrary, that the floodway extends from the stream to 50 feet from the top of the bank of the stream (See 25 PA Code § 105.1). The FEMA boundary is shown on the E&S drawings, when this information is available. When this information is not available, the floodway is shown as defined above for perennial and intermittent streams only.

2.0 SITE DESCRIPTION

SPLP is proposing to construct the Project in Cambria Township, Cambria County, PA. The Ebensburg Pump Station, which will be connected to the PPP twenty-inch diameter transmission pipeline, will be located on Wilmore Road, Ebensburg, PA at latitude 40.449°, longitude -78.714°. The Project will include the construction of an access road, pump station installation, and site restoration. Pump station installation will include a bypass inlet, meter, the pump, strainers, and a flare. The proposed Project will be constructed within an LOD of approximately 4.44 acres in Cambria County.

Relevant topographic features including streams, streets, pipelines, structures, utility lines, fences, paving and other significant items along the gas line alignment are indicated on the construction plans, where applicable.

2.1 TOPOGRAPHY

The work zone is located on ground of varying elevations. Site elevations vary from approximately 1823 feet (southeast portion of pad area) to 1880 feet (northwest portion of pad area) above mean sea level based on the Pennsylvania Spatial Data Access. The construction plans show the topography of the site and the surrounding area.

2.2 GEOLOGY AND SOILS

The soils and geologic formations surrounding the site are shown on the figures provided in Attachment 4. Attachment 4 also provides the soil descriptions and properties of the soils found at the site. In general, the following actions will be taken to counteract soil limitations:

- E&S BMPs will be in place and functional prior to earth disturbance to counteract erodible soils.
- Prompt stabilization practices will be implemented.
- Cut slopes will be stabilized as soon as possible with seed and mulch or erosion control blanket to prevent sliding.
- If a high groundwater table is encountered, water will be drained away from disturbed areas to a well vegetated area or a placed compost filter sock (CFS) prior to being discharged off the site. Water encountered during construction activities will be pumped through a pumped water filter bag to a well vegetated upland area. Saturated soils will be dried prior to being used on-site.
- Soils will be evaluated throughout the construction process to determine whether additional measures will need to be taken to make the soil suitable for its intended use on-site.
- Soil amendments will be added to site soils to promote vegetative growth.
- A wetland delineation and stream investigation has been conducted to determine the presence and location of hydric soils. No streams or wetlands have been identified within the LOD. There are streams and wetlands located on the property. To prevent sediment from leaving the site, E&SCs will be in place and functional prior to earth disturbances, and stabilization practices will be

implemented in disturbed areas as soon as practical. Geologic formations or soil conditions that may have the potential to cause pollution after earth disturbance were not observed during pre-design field activities.

The site consists of **Blairton-Berks channery silt loam (BpC), 8 to 15 percent slopes, Cookport and Ernest very stony soils (CvD), 8 to 25 percent slopes, and Laidig soils, 25 to 70 percent slopes (LDF)**, which are described below.

BpC – Blairton-Berks channery silt loam, 8 to 15 percent slopes.

Description of Blairton – This moderately well-draining soil is located on concave and concave hills at elevations ranging from 300 to 1,500 feet above mean sea-level. It is formed from local silty colluvium derived from shale and siltstone over acid and silty residuum weathered from shale and siltstone; colluvium derived from shale and siltstone. The typical soil profile is: 0 to 9 inches: channery silt loam (**Hydrological Soil Group B**); 9 to 30 inches: channery silt clay loam (**Hydrological Soil Group D**); and 30 to 38 inches: channery silt loam (**Hydrological Soil Group B**); 38 to 42 inches: bedrock. The depth to water table is 12 to 24 inches. The restrictive feature, lithic bedrock, is encountered 20 to 40 inches below the surface. There is no frequency of flooding or ponding.

Description of Berks – This well-draining soil is located on convex and convex hillslopes at elevations ranging from 300 to 1,500 feet above mean sea-level. It is formed from local silty colluvium derived from shale and siltstone over acid and silty residuum weathered from shale and siltstone; colluvium derived from shale and siltstone. The typical soil profile is: 0 to 8 inches: channery silt loam (**Hydrological Soil Group B**); 8 to 26 inches: very channery silt loam (**Hydrological Soil Group B**); and 26 to 30 inches: very channery loam (**Hydrological Soil Group B**); 30 to 34 inches: bedrock. The depth to water table is more than 80 inches. The restrictive feature, lithic bedrock, is encountered 20 to 40 inches below the surface. There is no frequency of flooding or ponding.

Limitations – A high groundwater table is shown to exist within the Blairton soil group located on site which is a limiting condition and may require special construction considerations.

In the event that a high groundwater table is encountered during construction, water will be drained away from disturbed areas to a well vegetated area or alternatively to a placed compost filter sock (CFS) prior to being discharged off the site. Proper construction and placement of the CFS is described in Section 3.3 discussing the construction of BMP E&S controls.

In addition, high volumes of water encountered during construction activities will be pumped through a pumped water filter bag to a well vegetated upland area. Lastly, all Saturated soils encountered during construction will be dried prior to being used on-site. Drying of the soils is expected to be rapid due to the generally well-draining characteristics of the encountered soil morphologies.

CvD – Cookport and Ernest very stony soils, 8 to 25 percent slopes.

Description of Cookport – This moderately well-draining soil is located on concave and concave mountains at elevations ranging from 480 to 3,000 feet above mean sea-level. It is formed from colluvium derived from sandstone and siltstone. The typical soil profile is: 0 to 10 inches: channery loam (**Hydrological Soil Group A**); and 10 to 26 inches: channery loam (**Hydrological Soil Group A**); 26 to 40 inches: channery loam (**Hydrological Soil Group A**); 40 to 60 inches: channery sandy loam (**Hydrological Soil Group A**); 60 to 62 inches: bedrock. The depth to water table is 0 to 6 inches below the surface. The restrictive feature is encountered about 26 inches (fragipan) and 40 to 72 inches (lithic bedrock) below the surface. There is no frequency of flooding or ponding.

Description of Ernest – This moderately well-draining soil is located on concave and concave hills at elevations ranging from 480 to 3,000 feet above mean sea-level. It is formed from colluvium derived from shale and siltstone. The typical soil profile is: 0 to 8 inches: channery silt loam (**Hydrological Soil Group B**); and 8 to 26 inches: silty clay loam (**Hydrological Soil Group C**); 26 to 41 inches: channery silt loam (**Hydrological Soil Group B**); 41 to 61 inches: channery silt loam (**Hydrological Soil Group B**). The depth to water table is about 4 to 20 inches below the surface. The restrictive feature, fragipan, is encountered 17 to 36 inches below the surface. There is no frequency of flooding or ponding.

Limitations – A high groundwater table is shown to exist within the Cookport soil group located on site which is a limiting condition and may require special construction considerations.

In the event that a high groundwater table is encountered during construction, water will be drained away from disturbed areas to a well vegetated area or alternatively to a placed compost filter sock (CFS) prior to being discharged off the site. Proper construction and placement of the CFS is described in Section 3.3 discussing the construction of BMP E&S controls.

In addition, high volumes of water encountered during construction activities will be pumped through a pumped water filter bag to a well vegetated upland area. Lastly, all Saturated soils encountered during construction will be dried prior to being used on-site. Drying of the soils is expected to be rapid due to the generally well-draining characteristics of the encountered soil morphologies.

LDF – Laidig soils, 25 to 70 percent slopes. This well-draining soil is located on concave and concave mountains at elevations ranging from 400 to 3,800 feet above mean sea-level. It is formed from mountain-slope fine loamy colluvium derived from interbedded sedimentary rock. The typical profile is 0 to 7 inches: channery loam (**Hydrological Soil Group A**); 7 to 36 inches: channery loam (**Hydrological Soil Group A**); 36 to 50 inches: channery sandy loam (**Hydrological Soil Group A**); 50 to 65 inches: channery sandy loam (**Hydrological Soil Group A**). The depth to water table is approximately 28 to 36-inches. The

restrictive feature, fragipan, is encountered 30 to 50 inches below the surface. There is no frequency of ponding or flooding.

Limitations – A high groundwater table is shown to exist within the Laidig soil group located on site which is a limiting condition and may require special construction considerations.

In the event that a high groundwater table is encountered during construction, water will be drained away from disturbed areas to a well vegetated area or alternatively to a placed compost filter sock (CFS) prior to being discharged off the site. Proper construction and placement of the CFS is described in Section 3.3 discussing the construction of BMP E&S controls.

In addition, high volumes of water encountered during construction activities will be pumped through a pumped water filter bag to a well vegetated upland area. Lastly, all saturated soils encountered during construction will be dried prior to being used on-site. Drying of the soils is expected to be rapid due to the generally well-draining characteristics of the encountered soil morphologies.

2.3 SURFACE WATER HYDROLOGY

The project area surface water runoff drains 500 ft to the southeast to Sanders Run and Howells Run, which are designated as cold water fisheries (CWF) under PA Code 25 Chapter 93.

This E&SCP contains BMPs to maintain the designated use of the receiving waters. The locations of the receiving waters relative to the project area can be seen on Attachment 1, USGS Project Location figure.

No streams and wetlands will be affected during construction.

3.0 EROSION AND SEDIMENT CONTROL PRACTICES

Two general types of E&SCs will be used on-site during construction: stabilization controls and structural controls. Stabilization controls are implemented as needed to preserve existing vegetation or disturbed areas. Structural controls are used to divert or convey runoff, prevent sediment migration, and reduce the erosive runoff forces. For the purposes of this plan, structural controls are mainly temporary; however, some of the controls may be permanent. The following sections describe the construction sequence and the E&SCs.

3.1 CONSTRUCTION SEQUENCE

Refer to the E&SCP drawings for the location of the proposed work and the associated BMPs. A generalized construction sequence is provided below. The construction sequence is intended to provide a general course of action in order to conform to the applicable regulatory agency requirements for temporary and permanent soil E&SCs. Necessary components for proper and complete execution of work pertaining to this plan, whether specifically mentioned or not, are to be performed by the contractor. It is not intended that the drawings and this report show detailed information on methods and materials. The contractor will comply with all requirements listed in this section, and will comply with the PA E&SC Manual. The contractor may be required to alter controls based on effectiveness of controls or differing conditions encountered in the field.

A preconstruction meeting is required prior to the start of any construction activity. The owner and/or operator will invite all contractors, the landowner, appropriate municipal officials; the E&SCP preparer, and a representative from the local PADEP or Conservation District to an on-site preconstruction meeting at least 7 days prior to construction commencement.

1. Locate staging areas and access points including construction entrances and access roads. Install compost filter sock (CFS) down slope of these areas. The project area surface water runoff drains to the south to Howells Run and to the east to Sanders Run, which are located in a CWF watershed. ABACT BMPs will be implemented, since both Howells Run and Sanders Run are siltation impaired waters.
2. Install rock construction entrances as needed. Refer to the rock construction entrance detail on drawings for suggested dimensions. A wash rack or ABACT Equivalent must be implemented to minimize additional sediment to siltation impaired watersheds. Install culvert as necessary according to the culvert installation construction sequence to bypass roadside ditch runoff.
3. Flag Project Limits of disturbance and clear vegetation within the grading boundary limits.
4. Install access road through property, including permanent channels. Stabilize the access road and permanent channels as indicated on plans. .
5. Locate and stake out all special areas of concern or areas of avoidance (i.e., streams).

6. Install CFS along the perimeters of the site as shown on the construction drawings. Installations sizing and spacing must conform to the chart and details provided on the E&SC detail sheet. Install vegetated channels and rock filters as indicated.
7. Strip topsoil from pad and access road area (where required) and stockpile within the LOD in accordance with the details provided.
8. Minimize total area of disturbance. Maintain temporary soil stockpiles within existing soil E&SCs. Should excavation enter streams/drainage-ways, follow specific details for these areas shown on the drawings and include the steps detailed in the specific sections below.
9. Grade surface to finished grade elevations as soon as practicable following completion of the pump station equipment installation. Immediately seed and mulch disturbed areas or gravel per the plan.
10. Install Erosion control blanket on all slopes 3:1 or steeper and within 100 feet of receiving waters. Locations are shown on plan sheets.
11. Maintain E&SC devices until site work is complete and a uniform 70-percent perennial vegetative cover is established. Relocate vegetated channels to permanent channel locations.
12. Remove E&SC measures upon establishment of a uniform 70-percent vegetative cover over the disturbed area. Re-grade and revegetate areas disturbed during the removal of the soil E&SCs.

3.2 BEST MANAGEMENT PRACTICES

An effective method to minimize E&S migration is to promote and implement BMPs. BMPs are relatively simple, inexpensive, and cost-effective protocols to prevent E&S migration. The basic BMPs that are anticipated to be employed during the construction activities include:

- Minimizing disturbances to site areas, especially those currently covered with pavement or vegetation.
- Minimize the time that soil is exposed.
- Prevent the runoff from flowing across disturbed areas (divert the flow to vegetated areas).
- Stabilize disturbed soils as soon as possible.
- Slow down the runoff flowing across the site.
- Remove sediment from surface water runoff before it leaves the site.

3.3 DESCRIPTION OF BMPs

General stabilization and structural controls will be used in E&SC practices to (1) divert stormwater flows away from exposed areas, (2) convey runoff, (3) prevent sediments from moving off-site, and (4) reduce the erosive forces of runoff waters. CFSs and other structural and non-structural controls that will be used during construction activities will include the following:

Vegetative Stabilization Controls

Grounds disturbed by any of the operations necessary to complete the work for this project are to be permanently seeded, or if specified, sodded, unless occupied by structures, gravel or paved. A temporary cessation of earth disturbance activities that lasts 4 days or longer requires temporary stabilization. Disturbed areas, which are at final grade, will be seeded and mulched immediately.

If seeding cannot be completed immediately after the area reaches final grade due to weather conditions, the disturbed area will be stabilized and mulched with straw at the rate of 3 tons per acre. This straw will be anchored using a method described under Mulching of this narrative.

Structural Controls

Temporary control facilities to be used during construction include the use of CFS and rock construction entrances. Other structural controls as described below may also be used as deemed necessary based on conditions encountered in the field. Installation guidelines and locations for the above devices are as shown on the drawings and additional information can be found in the PA E&SC Manual. The temporary control measures that will be used on this Project include, but are not limited to:

- *Compost Filter Socks* - This temporary sedimentation control measure consists of wood or metal posts driven through a compost filled mesh tube. Filter socks will be located as needed on side-slope and down-slope boundaries of disturbed areas. Both ends of each CFS should be extended at least 8 feet upslope CFS will be sized using the PADEP Construction Detail provided in Attachment 3. CFSs will be used in drainage areas with siltation impaired waters.
- Silt fence will not be used in drainage areas with HQ, EV, or Siltation impaired waters – (See Compost Filter Socks).
- *Tarpaulin Covers* - Tarpaulin covers may be used, as necessary, to protect topsoil storage stockpiles from wind and precipitation erosion. Stockpile slopes will be 2:1 or less. A minimal amount of soil will be stockpiled so that the height of the stockpile is less than 35 feet.
- *Rock Construction Entrance* - Temporary access routes will be established to facilitate construction activities. The use of access routes will help confine truck and equipment traffic to specific corridors thus minimizing land disturbance and protecting vegetation. Site traffic during wet weather will be limited. No vehicles will be permitted in streams or rivers.
- *Wash Racks* - Wash racks may be used at rock construction entrances and will be designed to accommodate anticipated vehicular traffic in special protection watersheds. A water supply will be made available at wash racks to wash the wheels of vehicles exiting the site. Reasonable methods which are sanctioned by the PADEP as alternatives to installation of tire wash stations on public road access points for station projects in EV/HQ or siltation impaired watersheds include:
 - For paved surface public roads: use of a vacuum truck sweeper or sweeper with a catch bin attachment.

- For dirt or gravel surface public roads: rigorous manual removal of mud/dirt from vehicle/equipment tires prior to exiting construction-site, supplemented by immediate recover, by manual or mechanical means, of soil which may become discharged onto public roadways, and dust control and/or compaction via rolling of the dirt public road surface will be implemented as needed.

A predicate for using the alternatives above is that the rock pad construction entrance will be extended to a minimum total length of 100 feet and will be constantly maintained including structure thickness to insure its effectiveness remains intact at all times.

Frequency of mechanical and/or manual controls will be dependent upon construction traffic intensity, weather, and soil moisture conditions. At a minimum for paved roads - any day in which construction traffic is exiting the rock construction entrance, the vacuum truck sweeper or sweeper with a catch bin attachment will clean the roadway at the end of the work day and prior to any forecasted rain event. The requirement is to not introduce sediment load from construction traffic onto public road surfaces and into road ditches which will flow into the special protection or siltation impaired water resources which are the subject of the increased protection measures.

Wash racks or alternative methods, as described above, must be used during construction because the site is located in a siltation impaired watershed. ABACT approved BMPs are to be used at all times for this site construction.

- *Pumped Water Filter Bag* - Pumped water filter bags may be used to filter water pumped from disturbed areas prior to discharging to surface waters. CFSs will be installed within 50 feet of any receiving surface water or where grassy area is not available. Filter bags will be installed according to the details shown in the PADEP Construction Detail provided in Attachment 3.
- *Erosion Control Blanket* - A manufactured erosion control blanket will be installed on all slopes 3:1 or steeper and within 50 feet of surface water or 100 feet of special protected water. The blanket will be biodegradable but capable of providing protection for 2 growing seasons. Straw or similar fiber material will be placed between two biodegradable nets. The top net will be heavyweight and UV stabilized; the bottom net will be a lightweight netting. Erosion control blankets will be anchored and stapled in place in accordance with the manufacturer's recommendations and the detail on the construction drawings. For slopes between 3:1 and 1:1, use erosion control blanket SC 150 as manufactured by North American Green or Owner approved equal material or equal method.
- *Vegetated Channels* – Vegetated channels will be installed along the western side of the access road and in the northern most corner of the proposed LOD. The vegetated channels are intended to divert stormwater runoff around areas of earth disturbance and convey it to a sediment removal structure before discharging into receiving surface waters. The vegetated channels shall be installed according to the Construction Detail provided in Attachment 3.

- *Riprap Apron* – Riprap aprons will be installed at pipe outlets in order to prevent scour where anticipated discharge velocities do not exceed 17 feet per second, there is sufficient room to construct the apron, and where the apron can be installed on a level grade. The apron will be oriented so that the discharge enters the receiving channels at less than 90 degrees to the channel flow direction.
- *Public ROWs* - In an effort to reduce the tracking of sediment onto public ROWs, stabilized construction entrances of crushed stone located at points where traffic will be entering or leaving the site will be installed. Mud and soil accumulating on roadways, as a result of construction activities, will be removed with hand tools, such as shovels, and disposed of properly. The contractor will check the road a minimum of twice daily to verify cleanliness at road crossings and take necessary corrective action. Gravel will be used to limit dust and erodibility.
- *Restoration* - All improved areas disturbed by construction will be restored.
- *Additional Requirements* - Any additional requirements to adequately control E&S pollution will be the responsibility of the contractor and will be considered incidental to construction activities.

3.4 PRIMARY CONSTRUCTION ACTIVITIES

Clearing and Grubbing

Brush, scrub growth, saplings and trees directed to be cut and removed will be completely removed from the site of the work, if encountered. The contractor will remove stumps and large roots and refill the depressions with suitable compacted earth fill where necessary to bring the grade back to its original elevation or final design grade. The contractor will protect exposed bare earth using mulch or other appropriate measures if clearing and grubbing operations are completed more than 4 days prior to pump station construction activities.

Grading and Topsoil Stockpiling

Before beginning excavation and/or filling work, the topsoil or gravel from all areas to be affected will be stripped and stockpiled in a separate stockpile from the other excavated soil material. After completion of the major construction work, the topsoil will then be replaced as the upper layer of backfill. In general, all topsoil stockpiles will be located within the LOD away from nearby streams and/or drainage ditches or watercourses. Temporary erosion protection devices such as CFS will be used to protect all stockpiled topsoil from being carried into nearby water courses by the action of any overland runoff water.

As topsoil stockpile(s) become(s) completely depleted, the disturbed area(s) will be graded and revegetated or finished with gravel. The CFS will be removed only after a uniform 70-percent perennial vegetative coverage has been established across the disturbed area.

Topsoil will not be placed when the subgrade is frozen or when it is excessively wet or dry, and will not be handled when in a frozen or muddy condition.

The contractor shall be responsible for completing their environmental due diligence and ensuring that all fill material brought on site is clean fill.

Vegetation

Grounds that are not gravely disturbed by any of the operations necessary to complete the work for this Project are to be permanently seeded, unless occupied by structures or paved. Any temporary cessation of earth disturbance activities, which lasts for 4 days or longer, requires temporary stabilization. Disturbed areas, which are at final grade, will be seeded and mulched immediately.

If seeding cannot be completed immediately after the area reaches final grade due to weather conditions, the disturbed area will be stabilized and mulched with straw at the rate of three tons per acre. This straw will be anchored using a method described under Mulching of this narrative.

Seeded areas will be inspected weekly and after each runoff event. Necessary repairs will be made by the end of the week.

Permanent Seeding

The site preparation and establishment of permanent cover will be conducted according to the following guidelines:

1. Install needed surface water control measures.
2. Hydroseed or follow Steps 3 through 6 below.
3. Perform all cultural operations at right angles to the slope.
4. Determine agricultural lime application rates by field pH testing. Perform testing at a rate of 1 test per acre (min.). In the absence of testing, apply at 6 tons per acre.
5. Apply dry 10-20-20 formulation of fertilizer at the rate of 678 lbs. per acre or at a rate determined by field testing.
6. Work in lime and fertilizer to a depth of 4 inches using suitable equipment.
7. Seed Mixture - The seed mixture will be:

TABLE 1: PENNDOT FORMULA W							
SCIENTIFIC NAME	COMMON NAME	REQUIRED VARIETIES	% BY WEIGHT	MINIMUM % PURITY	MINIMUM % GERMINATION	MAX % WEED	SEEDING RATE (LBS/ 1000 SF)
Festuca Arundinacea	Tall Fesuce	Festuca arundinacea var. Kentucky 31	70	98	85	0.15	7.5

TABLE 1: PENNDOT FORMULA W							
SCIENTIFIC NAME	COMMON NAME	REQUIRED VARIETIES	% BY WEIGHT	MINIMUM % PURITY	MINIMUM % GERMINATION	MAX % WEED	SEEDING RATE (LBS/ 1000 SF)
Lotus Corniculatus	Birdsfoot Trefoil Mixture	A combination of varieties (Viking, Empire, Norcen, Dawn, Leo, Bull, Maitland) with no one variety exceeding 50% of the total Trefoil component.	20	98	80 ⁽¹⁾	0.10	2.0
Agrostis Alba	Redtop	Agrostis alba	10	92	80	0.15	1.0

⁽¹⁾ Recommended 10% hardseed and 70% normal sprouts.

8. If not hydroseeding, apply mulch.

Notes:

1. Spread seeds where indicated and at the rates specified in Table 1, or as otherwise indicated.
2. Spread seeds within April 1 to June 15 or August 16 to September 15.
3. Extend seeding dates where project conditions warrant. Apply full treatment or apply only 50% of the permanent seeding and soil supplements and apply the remaining 50% within the next seeding dates, as directed in writing.
4. Use tillage and soil supplements before permanent seeding on topsoiled areas, where temporary seeding or mulching has been applied.
 - a. On topsoiled areas, 1:3 (3:1) and flatter, loosen the surface to a depth of at least 50 mm (2 inches) by disking, harrowing, or other acceptable methods until the tillage is satisfactory. On untilled areas, 1:3 (3:1) and flatter, till only as directed. Also, till or scarify areas if the surface is glazed or crusted.
 - b. Correct surface irregularities by filling depressions and leveling rough or uneven areas. Remove metal objects, stones larger than 50 mm (2 inches) in any dimension, and other debris or objects deemed detrimental to maintenance operations.
5. Inoculate leguminous seed, such as Birdsfoot Trefoil, with proper cultures, according to the manufacturer's directions.
6. At the rates specified in Table 1, sow seeds uniformly on the prepared areas by the helicopter, hydraulic placement, broadcasting, drilling, or hand seeding methods. Inspect seeding equipment and adjust the equipment, if required, to ensure the specified application rates. Periodically perform a check on the rate and uniformity of application, as directed. Prior to seed application of each designated seed formula, thoroughly clean-out seed tank by rinsing with clean water to prevent contamination from one seed formula to the next. Repeat rinsing cycle until tank is clean. Collect all non-applied seed derived from each clean-out event and remove as waste from the project.
7. After seeding, roll topsoiled areas that are to be mowed. Use a roller with a mass (weight) not more than 100 kg/m (65 pounds per foot). If soil is wet or frozen, roll only when directed.
8. Apply herbicides as directed, to areas that are to be mowed and where weed growth is prominent. The Representative will designate existing plants or groups of plants to be saved within these areas before herbicide application. If directed, more than one application may be required to control undesirable growth.

Apply material with application personnel certified by the Department of Agriculture and with equipment specified in Section 108.05(c).

9. Final acceptance of seeding and soil supplement materials and installation are subject to the results of official sampling and testing as specified before use and installation and the resultant establishment of the specified vegetation. Remove non-approved materials from the project.
 - a. Reseed rejected areas with additional applications of the specified seed and soil supplement materials. Redress soil surfaces when directed. Perform reapplication of seed and soil supplements within the next applicable seeding date if necessary or as directed. When directed, reseed areas damaged by herbicide applications and mowing operations. NOTE: Reseeded areas will also require the application of appropriate mulch as specified in Section 805.
 - b. Seeded areas may be rejected based on the lack of actual grass seedling establishment exhibited in the area for the specified seed formula.
 - i. Table 1 formula seeded areas that exhibit less than 70% surface area coverage with the specified germinated grass seedlings after 90 days of growth may be rejected upon visual inspection. The seed germination and growth period is determined from the date of the seeding operation for the area when these operations are performed within the specified seeding dates.
 - ii. Special seed formula planted areas (seed mixtures not indicated in Table 1) may be rejected based on the lack of the specified seed germination and growth of less than 11 seedlings/m² (9 seedlings/square yard) after 120 days of growth determined by visual inspection. The seed germination and growth period is determined from the date of the seeding operation of the area when these operations are performed within the specified seeding dates.
 - iii. Seeded areas exhibiting soil surface erosion rills or gullies deeper than 250 mm (1-inch) may be rejected upon visual inspection. Redress and reseed designated eroded areas with specified materials and application rates as directed.

Liming Rates

Minimum 6 tons per acre at 100% effective neutralizing value (% ENV), unless the soil test determines that a lesser amount is needed. To determine the actual amount of regular lime to apply, divide the amount called for by the soil test by the % ENV for the product used. For example, if 6 tons per acre is needed and the ENV for the lime used is 88%, divide 6 by 0.88 resulting in 6.8 tons needing to be applied. For dolomitic lime, which has a significant amount of magnesium in it, divide the amount called for by the soil test by the % calcium carbonate equivalent (% CCE) listed for the product instead of the % ENV. The % CCE may be above 100% which accounts for the fact that magnesium has a greater effect per pound than the calcium in regular lime. Note: When a soil test requires more than 8,000 pounds of lime per acre, the lime must be mixed into the top 6 inches of soil.

Fertilization Rates

Prepare areas for seeding by uniformly applying supplements. Document bulk delivery. Blend the initial soil supplements into the soil at least 50 mm (2 inches), on topsoiled areas, by raking, disking, harrowing, or other acceptable methods. Blend the supplements into the soil during tillage operations. Apply slow-release nitrogen fertilizer to the surface of Formula W seeded areas before project completion. Apply soil supplements as shown in the following table, unless otherwise indicated:

Permanent Seeding Application Rate				
Soil Amendment	Per Acre	Per 1,000 sq. ft.	Per 1,000 sq. yds.	Notes
Agricultural Lime	3872 LBS.	89 LBS.	800 LBS.	or as per soil test; may not be required in agricultural fields
10-20-20 Fertilizer	678 LBS.	16 LBS.	140 LBS.	
38-0-0 Ureaform Fertilizer, OR	242 LBS.	6 LBS.	50 LBS.	
32-0-0 to 38-0-0 Sulfur Coated Urea Fertilizer, OR	286 LBS.	7 LBS.	59 LBS.	
31-0-0 IBDU Fertilizer	295 LBS.	7 LBS.	61 LBS.	

Temporary Seeding

Temporary grass cover will be established in the following areas:

- Where vegetative filters must be established below filter bags, a minimum distance of 10 feet will be seeded down slope of the trap outlet. Seed mixture for temporary cover will consist of 100-percent annual ryegrass. Seed will be applied at the rate of 40 lb. per acre or as recommended by a local recognized seed supplier and approved by the owner's representative. Prior to seeding, apply 1 ton of agricultural grade limestone per acre plus 10-10-10 fertilizer at the rate of 500 lb. per acre and work into soil.
- Where soil stockpiles are to be exposed for a period greater than four (4) days, the stockpile shall be seeded.

Temporary Seeding Application Rate				
Soil Amendment	Per Acre	Per 1,000 sq. ft.	Per 1,000 sq. yd.	Notes
Agricultural Lime	1 ton	40lb.	410 lb.	Typically not required for topsoil stockpiles
10-10-10 Fertilizer	500lb.	12.5 lb.	100lb.	Typically not required for topsoil stockpiles

Mulching

The purpose of mulch is to reduce runoff and erosion, prevent surface compaction or crusting, conserve moisture, aid in establishing plant cover, and control weeds. Mulch will be applied on any area subject to erosion, or which has unfavorable conditions for plant establishment and growth. The practice will be used alone or in conjunction with other structural and vegetative conservation practices, such as waterways, ponds, sedimentation traps or critical area planting. On sediment producing areas where the period of exposure is less than 2 months, mulch materials will be applied according to the following guidelines:

- Apply straw mulch at the rate of 3 tons per acre. Chemically treated or salted straw is not acceptable as mulch.
- Anchor straw mulch immediately after application by at least one of the following methods.
 - A. “Crimp” straw mulch into the soil using tractor drawn equipment (straight bladed coulter or similar). This method is limited to slopes no steeper than 3:1. Operate machinery on the contour. Crimping of hay or straw by running it over with tracked machinery is not recommended.
 - B. Uniformly apply asphalt, either emulsified or cut-back, containing no solvents or other diluting agents toxic to plant or animal life, at the rate of 31 gallons per 1,000 square feet.
 - C. Use synthetic binders (chemical binders) as recommended by the manufacturer to anchor mulch provided sufficient documentation is provided to show that it is non-toxic to native plant and animal species.
 - D. Staple lightweight plastic, fiber, or paper nets over the mulch according to the manufacturer’s recommendations.

Mulched areas will be checked periodically and after each runoff event (e.g. rain, snowmelt, etc.) for damage until the desired purpose of the mulching is achieved. Damaged portions of the mulch or tie-down material will be repaired upon discovery.

Waste Considerations

The operator will remove from the site, recycle, or dispose of all building materials and wastes in accordance with PADEP’s solid waste management regulations at 25 PA Code 260.1 et seq., 271.1 et seq., and 287.1 et seq. The contractor will not illegally bury, dump, or discharge building material or wastes at the

site. Excess material brought into the site areas to facilitate construction access will be completely removed prior to rough grading and final surface stabilization. Expected construction wastes will consist of packaging material and sediment cleaned from BMPs. Packaging from the materials brought on-site will be disposed of by a licensed hauler. Sediment removed from BMPs will either be spread in a protected area to dry and then recycled as fill material or disposed of off-site. In cases where disposal is necessary, waste materials are to be disposed of off-site at an approved PADEP waste disposal facility.

Thermal Impacts

Potential pollution to surface waters from thermal impacts will be minimized by minimizing clearing and retaining existing vegetation where possible during construction. Following construction, permanent seeding will occur around the pad as soon as practicable to facilitate vegetative growth.

Earth disturbance activities associated with the Project will be located within a HQ/TSF watershed. Accelerated E&S will be minimized to achieve zero net change in runoff between the pre and post-construction conditions. The extent of the disturbed area will be minimized, and the duration of disturbance will be minimized by stabilizing disturbed areas as soon as practicable. Due to the size and location of the pad, it is not anticipated that adverse thermal impacts to surface waters will occur.

The receiving streams are classified as not attaining their existing water quality of a HQ/TSF. Reasons listed were impaired aquatic life due to urban runoff/storm sewers – siltation, water/flow variability, and other unknown causes. BMPs will be used onsite to protect and maintain their existing use.

ABACT BMPs will be used onsite to protect and maintain the existing water quality of receiving waters.

The following ABACT E&S BMPs will be used onsite:

- Wash racks or alternatives at rock construction entrances.
- CFS used in place of silt fence.
- Erosion control blanket on disturbed areas within 100 feet of a receiving surface waters, where applicable, and on slopes 3:1 or steeper.

Riparian Forest Buffers

Existing riparian forest buffers do not exist within the Project area.

3.5 MAINTENANCE AND INSPECTION PROCEDURES

Maintenance to the temporary E&SC structures will be performed by the contractor during the construction period. Maintenance for E&S devices will occur, at a minimum, as follows:

Compost Filter Socks

- Accumulated sediment will be removed as required, and in all cases where uniform accumulations are one-half the above ground height of the filter sock. Any accumulated earth behind the filter sock will be disposed of by the contractor in such a manner that the removed earth will not be excessively eroded and transported into a waterbody.
- The filter sock installation will be inspected weekly and after every runoff event. Loosened support stakes will be removed and new stakes driven. Filter socks will be maintained and repaired as per manufacturer specifications.
- Temporary E&SCs will be removed by the contractor only after a uniform 70-percent perennial vegetative coverage has been established across the disturbed area. Temporary E&SCs will be disposed of by the contractor at an approved PADEP disposal facility.

Rock Construction Entrances

- Rock construction entrance thickness will be constantly maintained to the specified dimensions by adding rock. A stockpile will be maintained on-site for this purpose.

Pumped Water Filter Bags

- Filter bags will be replaced when they become one-half full of sediment.
- Filter bags will be inspected daily. If any problem is detected, pumping will cease immediately and not resume until the problem is corrected.

Vegetation

- Seeded areas will be inspected weekly and after each runoff event. Necessary repairs will be made immediately.

Mulch

- Mulched areas will be checked periodically and after severe storms for damage until the desired purpose of the mulching is achieved. Damaged portions of the mulch or tie-down material will be repaired upon discovery.

Inspection and Maintenance

Until the site is stabilized, E&SC BMPs will be maintained properly. Preventative and corrective maintenance work, including clean-out, repair, replacement, regrading, reseeding, remulching, and renetting will be performed as soon as practical. If E&SC BMPs fail to perform as expected, replacement

BMPs, or modifications to those installed will be required. The following inspection and maintenance practices will be used to maintain E&SC on-site during activities.

- E&SC measures will be in-place and inspected at the end of the workday and after each runoff event. The contractor will immediately repair any deficiencies.
- Maintenance and inspection of sediment control facilities will conform to PADEP Chapter 102 and 105 rules and regulations.
- Sediment will be removed when it accumulates one-half the aboveground height of the CFS. All undercutting of erosion of the toe anchor will be repaired with compacted backfill material. Adhere to the manufacturer's recommendations for replacing filter socks due to weathering.
- Sediment removed from CFS and any other control devices will be mixed in with the other waste soil on the construction site and properly disposed of as discussed in Section 3.4.
- Sediment will be removed from the sediment removal facilities associated with wash racks as necessary. Sediment deposited on paved roadways will be removed and returned to the construction site daily, at a minimum.
- Re-vegetated areas will be inspected for bare spots, washouts, and healthy growth during the construction. Identified bare spots and washouts will be repaired as soon as practical.
- All soil stockpiles that are to remain more than 4 days will be seeded with temporary grass, as noted in the seeding specification on the construction drawings.
- The contractor will make certain that all runoff is directed to the sedimentation control devices.
- All sedimentation control measures will remain in place until the disturbed areas are stabilized and a uniform 70-percent perennial vegetative cover is established. Any area not achieving a 70-percent vegetative cover will be re-seeded and mulched.

If E&S BMPs are found to be inoperative or ineffective during an inspection, PADEP should be contacted within 24 hours, followed by the submission of a written noncompliance report to PADEP within 5 days of the initial contact.

Long-Term Maintenance

The owner will maintain the stormwater management facilities for this site. Maintenance of the stormwater management facilities includes, but is not limited to, the following:

1. The proposed stormwater detention system, private storm systems, and stormwater BMP's will be inspected and maintained by the property owner in accordance with the approved operation and maintenance program.
2. The stormwater BMP's are fixtures that can be altered or removed only after approval by the Municipality.

3.6 ANTIDegradation

Earth disturbance activities associated with the Ebensburg Pump Station will be located within CWF watershed. A combination of non-discharge alternatives and the use of BMPs on-site will protect and maintain the existing water quality of the receiving waters.

Non-discharge alternatives were evaluated to minimize accelerated E&S and achieve zero net charge in runoff between the pre and post-construction conditions. The extent of the disturbed area will be minimized, and the duration of disturbance will be minimized by stabilizing disturbed areas as soon as practicable. ABACT BMPs will be used onsite to protect and maintain the existing water quality of receiving waters.

The following ABACT BMPs will be used onsite when in HQ or EV areas:

- Wash racks located at rock construction entrances,
- CFS used in place of silt fence in HQ watersheds,
- Erosion control blanket on disturbed areas within 100 feet of a receiving surface waters, where applicable, and on slopes 3:1 or steeper.

3.7 SITE RESTORATION

Past and present land use of the project area and surrounding area is agricultural, woodland, and meadow land. Future land use will be restored to a gravel pad and gravel rock construction entrance, and access road surrounded by land in good condition. Primary receiving water outside the project area consists of: Howells Run (CWF) and Sanders Run (CWF). Secondary waters include Howells Run (CWF) Sanders Run (CWF). Location and types of soils are shown on the Soils Map and outlined in Section 2.3 of this narrative. In general, the following procedures will be implemented to counteract soil limitations:

- E&S BMPs will be in place and functional prior to earth disturbance to counteract erodible soils.
- Should a high water table be encountered during excavation procedures, the trench will be dewatered using a pumped water filter bag.
- Soils amendments will be added to soils that are found to be a poor source of topsoil.

Following completion of the Project, minor increases in stormwater runoff may occur. Ultimately, the site will be composed of restored areas and a gravel pad for the pump station. The restored areas will be vegetated to the equivalent of "meadow in good condition," and the gravel pad will consist of mostly non-compacted yard gravel, which will promote infiltration and evaporation.

4.0 REFERENCES

Erosion and Sediment Pollution Control Program Manual, Commonwealth of Pennsylvania, Department of Environmental Protection, Office of Water Management, March 2012.

Stormwater Management for Construction Activities - Developing Pollution Prevention Plans and Best Management Practices, United States Environmental Protection Agency, Office of Water, 1993.

Ebensburg Quadrangle, Pennsylvania - Cambria County, Geological Survey, United States Department of Interior.

Web Soil Survey of Cambria County, Pennsylvania, United States Department of Agriculture, Soil Conservation Service, November, 2015.

Pennsylvania Stormwater Best Management Practices Manual Draft, Pennsylvania Department of Environmental Protection, Bureau of Watershed Management, November, 2009.

ATTACHMENT 1:
USGS Location Map

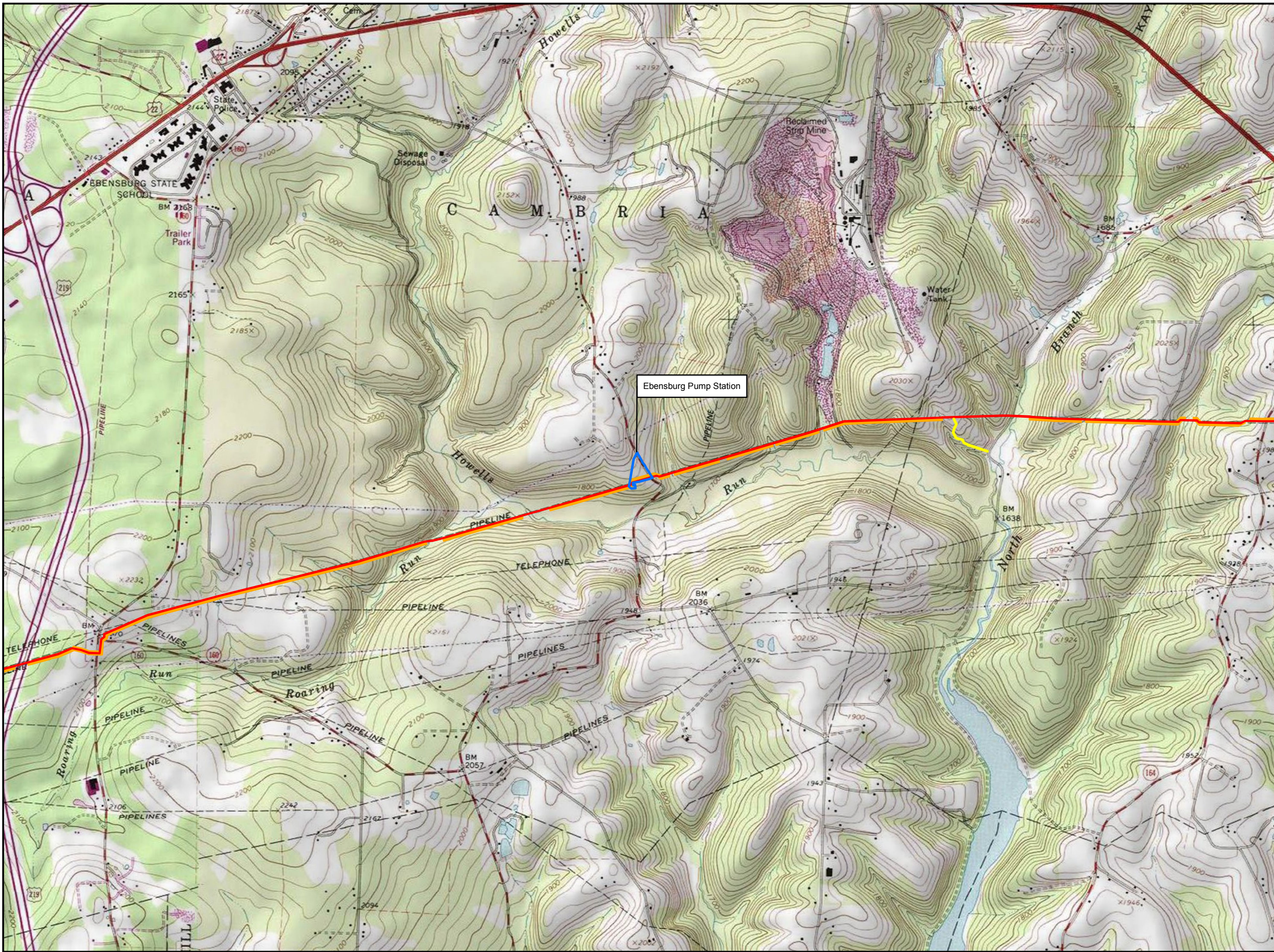

- Legend**
- Access Road
 - Alignment Centerline
 - Limit of Disturbance
 - Pump Station

Ebensburg Pump Station

Sheet Identifier

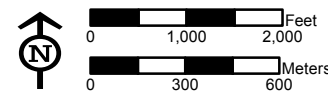
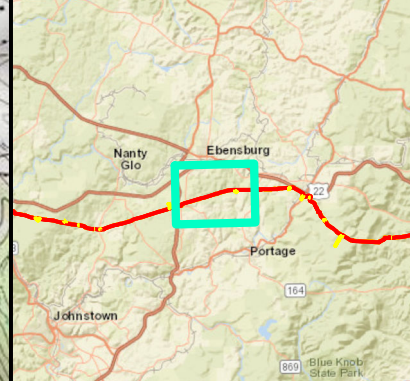

**PROJECT LOCATION MAP
ATTACHMENT 1
PENNSYLVANIA PIPELINE PROJECT
OCTOBER 3, 2016 ALIGNMENT
SUNOCO LOGISTICS, L.P.
CAMBRIA COUNTY, PA**



Notes:
 1) Topographic map provided by ESRI's ArcGIS Online USA Topo Maps map service (© 2013 National Geographic Society, I-cubed).
 2) Quadrangles being displayed are Ebensburg

P:\GIS\SUNOCO\MARINER EAST 2\MD\PPP_ESCGRP\PUMP STATIONS\PPP_PIPELINE_PUMPSTATIONS_USGS_ESCGRP_MXD_1011416.PDF

ATTACHMENT 2:
E&S Plan Sheets

SEE FULL SIZE DRAWINGS

ATTACHMENT 3:
Construction Details

STANDARD E&S WORKSHEET # 8 Rock Filters

PROJECT NAME: Sunoco PPP - Ebensburg Station
 LOCATION: Wilmore Road, Ebensburg, PA
 PREPARED BY: Michael Smith DATE: 10-11-16
 CHECKED BY: Tim Dunaway DATE: 10-21-16

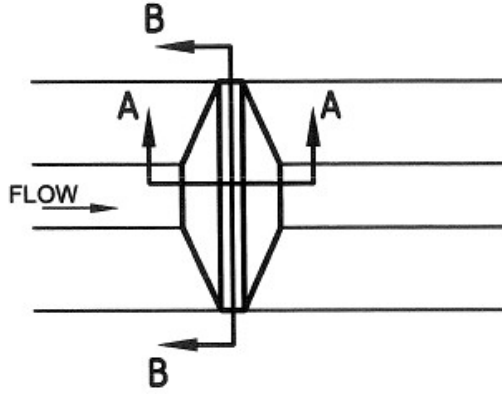

PLAN VIEW

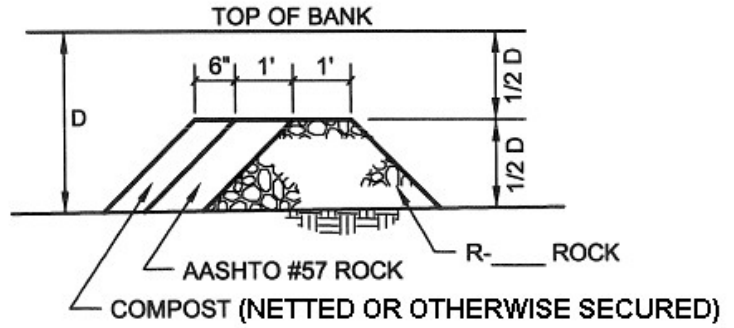

SECTION A-A

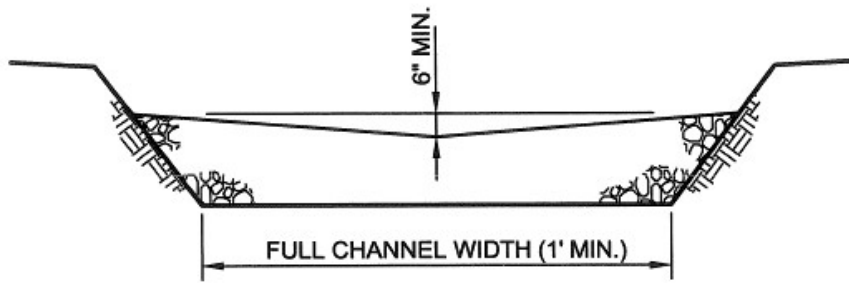

SECTION B-B

Note: Not Suitable for Channels less than two feet total depth

ROCK FILTER NO.	LOCATION	D (FT)	RIPRAP SIZE
1-3	Channel B-C	2	R-3

STANDARD E&S WORKSHEET # 11
Channel Design Data

PROJECT NAME: Sunoco PPP – Ebensburg Station

LOCATION: Wilmore Road, Ebensburg, PA

PREPARED BY: Michael Smith

DATE: 10-11-16

CHECKED BY: Tim Dunaway

DATE: 10-21-16

CHANNEL OR CHANNEL SECTION		A	B	C		
TEMPORARY OR PERMANENT? (T OR P)		P	P	T		
DESIGN STORM (2, 5, OR 10 YR)		100	100	2		
ACRES (AC)		2.15	0.3	0.3		
MULTIPLIER (1.6, 2.25, or 2.75) ¹		N/A	N/A	1.6		
Q _r (REQUIRED CAPACITY) (CFS)		10.97	2.19	0.5		
Q (CALCULATED AT FLOW DEPTH d) (CFS)		10.97	2.19	0.5		
PROTECTIVE LINING ²		Grass + TRM	Grass + TRM	Grass + TRM		
n (MANNING'S COEFFICIENT) ²		0.03	0.03	0.03		
V _a (ALLOWABLE VELOCITY) (FPS)		8	8	8		
V (CALCULATED AT FLOW DEPTH d) (FPS)		3.34	3.42	4.11		
a (MAX ALLOWABLE SHEAR STRESS) (LB/FT ²)		N/A	N/A	N/A		
d (CALC'D SHEAR STRESS AT FLOW DEPTH d) (LB/FT ²)		N/A	N/A	N/A		
CHANNEL BOTTOM WIDTH (FT)		2	2	0		
CHANNEL SIDE SLOPES (H:V)		2	2	2		
D (TOTAL DEPTH) (FT)		2	2	2		
CHANNEL TOP WIDTH @ D (FT)		6	6	6		
d (CALCULATED FLOW DEPTH) (FT)		0.87	0.25	0.25		
CHANNEL TOP WIDTH @ FLOW DEPTH d (FT)		5.5	3.0	1.0		
BOTTOM WIDTH: FLOW DEPTH RATIO (12:1 MAX)		2.3	8	0		
d ₅₀ STONE SIZE (IN)		N/A	N/A	N/A		
A (CROSS-SECTIONAL AREA) (SQ. FT.)		8	8	8		
R (HYDRAULIC RADIUS)		0.55	0.2	0.11		
S (BED SLOPE) ³ (FT/FT)		.01	0.04	0.13		
S _c (CRITICAL SLOPE) (FT/FT)		N/A	N/A	N/A		
.7S _c (FT/FT)		N/A	N/A	N/A		
1.3S _c (FT/FT)		N/A	N/A	N/A		
STABLE FLOW? (Y/N)		Y	Y	Y		
FREEBOARD BASED ON UNSTABLE FLOW (FT)		N/A	N/A	N/A		
FREEBOARD BASED ON STABLE FLOW (FT)		1.13	1.75	1.75		
MINIMUM REQUIRED FREEBOARD ⁴ (FT)		0.5	0.5	0.5		
DESIGN METHOD FOR PROTECTIVE LINING ⁵ PERMISSIBLE VELOCITY (V) OR SHEAR STRESS (S)		V	V	V		

1. Use 1.6 for Temporary Channels; 2.25 for Temporary Channels in Special Protection (HQ or EV) Watersheds; 2.75 for Permanent Channels. For Rational Method, enter "N/A" and attach E&S Worksheets 9 and 10. For TR-55 enter "N/A" and attach appropriate Worksheets.
2. Adjust "n" value for changes in channel liner and flow depth. For vegetated channels, provide data for manufactured linings without vegetation and with vegetation in separate columns.
3. Slopes may not be averaged.
4. Minimum Freeboard is 0.5 ft. or ' Total Channel Depth, whichever is greater
5. Permissible velocity lining design method is not acceptable for channels with a bed slope of 10% or greater. Shear stress lining design method is required for channels with a bed slope of 10% or greater. Shear stress lining design method may be used for any channel bed slope.

STANDARD E&S WORKSHEET # 20 Riprap Apron Outlet Protection

PROJECT NAME: Sunoco PPP - Ebensburg Station

LOCATION: Wilmore Road, Ebensburg, PA

PREPARED BY: Michael Smith

DATE: 10-11-16

CHECKED BY: Tim Dunaway

DATE: 10-21-16

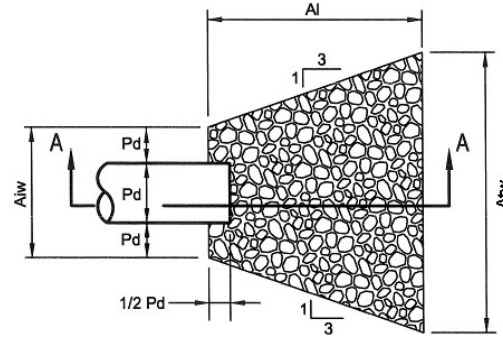

PLAN VIEW

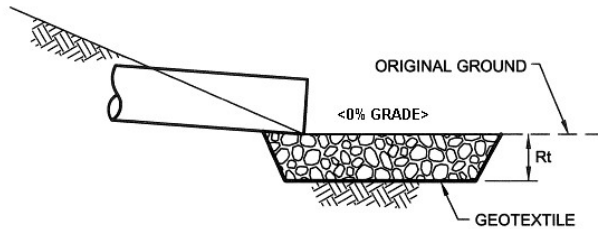

SECTION A - A

NO.	PIPE DIA. Do (in.)	TAIL WATER COND. (Max or Min)	MAN. "n" FOR PIPE	PIPE SLOPE (FT/FT)	Q (CFS)	V* (FPS)	RIPRAP SIZE	Rt (in)	Al (ft)	Aiw (ft)	Atw (ft)
OP-1	12	Min.	0.012	0.05	7.09	9.0	R-4	18	10	3	13
OP-2	15	Min.	0.012	0.013	2.19	1.6	R-3	9	9	3	12

*:The anticipated velocity (V) should not exceed the maximum permissible shown in Table 6.6 for the proposed riprap protection. Adjust for less than full pipe flow. Use Manning's equation to calculate velocity for pipe slopes ≥ 0.05 ft/ft.

**STANDARD E&S WORKSHEET # 22
PLAN PREPARER RECORD OF TRAINING AND EXPERIENCE IN EROSION AND
SEDIMENT POLLUTION CONTROL METHODS AND TECHNIQUES**

NAME OF PLAN PREPARER: Tim Dunaway

FORMAL EDUCATION:

Name of College or Technical Institute: West Virginia University

Curriculum or Program: Environmental Engineering

Dates of Attendance: From: 1994 To: 1997

Degree Received M.S. Engineering

OTHER TRAINING:

Name of Training: _____

Presented By: _____

Date: _____

EMPLOYMENT HISTORY:

Current Employer: Tetra Tech. Inc.

Telephone: 412-921-7090

Former Employer: _____

Telephone: _____

RECENT E&S PLANS PREPARED:

Name of Project: Houston Tank Farm _____

County: _____

Municipality: Chartiers Twp. _____

Permit Number: ESG0012515006-1 _____

Approving Agency: Wash. Co. Con. Dis. _____

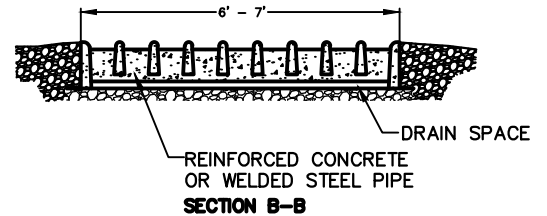
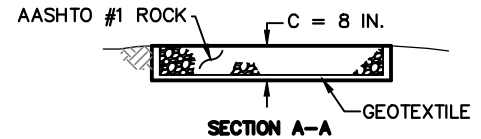
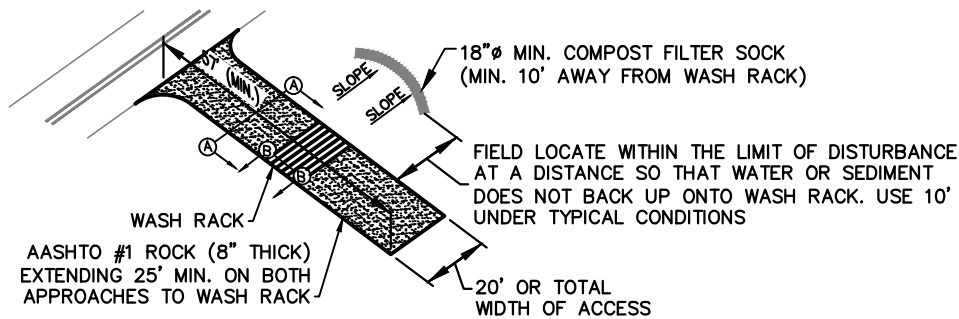

NOTE:

REASONABLE METHODS WHICH ARE SANCTIONED BY THE PADEP AS ALTERNATIVES TO INSTALLATION OF TIRE WASH STATIONS ON PUBLIC ROAD ACCESS POINTS FOR GATHERING PIPELINE PROJECTS IN EV/HQ WATERSHEDS INCLUDE:

1. FOR PAVED SURFACE PUBLIC ROADS: USE OF A VACUUM TRUCK SWEEPER OR SWEEPER WITH A CATCH BIN ATTACHMENT.
2. FOR DIRT OR GRAVEL SURFACE PUBLIC ROADS: RIGOROUS MANUAL REMOVAL OF MUD/DIRT FROM VEHICLE/EQUIPMENT TIRES PRIOR TO EXITING CONSTRUCTION SITE, SUPPLEMENTED BY IMMEDIATE RECOVER, BY MANUAL OR MECHANICAL MEANS, OF SOIL WHICH MAY BECOME DISCHARGED ONTO PUBLIC ROADWAYS. DUST CONTROL AND/OR COMPACTION VIA ROLLING OF THE DIRT PUBLIC ROAD SURFACE WILL BE IMPLEMENTED AS NEEDED.

A PREDICATE FOR UTILIZING ALTERNATIVE 1 AND 2 ABOVE IS THAT THE ROCK PAD CONSTRUCTION ENTRANCE MUST BE EXTENDED TO A MINIMUM TOTAL LENGTH OF 100 FEET AND MUST BE CONSTANTLY MAINTAINED INCLUDING STRUCTURE THICKNESS TO INSURE ITS EFFECTIVENESS REMAINS INTACT AT ALL TIMES.

FREQUENCY OF MECHANICAL AND/OR MANUAL CONTROLS WILL BE DEPENDENT UPON CONSTRUCTION TRAFFIC INTENSITY, WEATHER AND SOIL MOISTURE CONDITIONS. AT A MINIMUM FOR PAVED ROADS - ANY DAY IN WHICH CONSTRUCTION TRAFFIC IS EXITING THE ROCK CONSTRUCTION ENTRANCE, THE VACUUM TRUCK SWEEPER OR SWEEPER WITH A CATCH BIN ATTACHMENT SHALL CLEAN THE ROADWAY AT THE END OF THE WORK DAY AND PRIOR TO ANY FORECASTED RAIN EVENT. THE REQUIREMENT IS TO NOT INTRODUCE SEDIMENT LOAD FROM CONSTRUCTION TRAFFIC ONTO PUBLIC ROAD SURFACES AND INTO ROAD DITCHES WHICH WILL FLOW INTO THE EV/HQ WATER RESOURCES WHICH ARE THE SUBJECT OF THE INCREASED PROTECTION MEASURES.

AASHTO #1 ROCK CONSTRUCTION ENTRANCE
NOT TO SCALE

**STANDARD CONSTRUCTION DETAIL # 11-1
Erosion Control Blanket Installation**

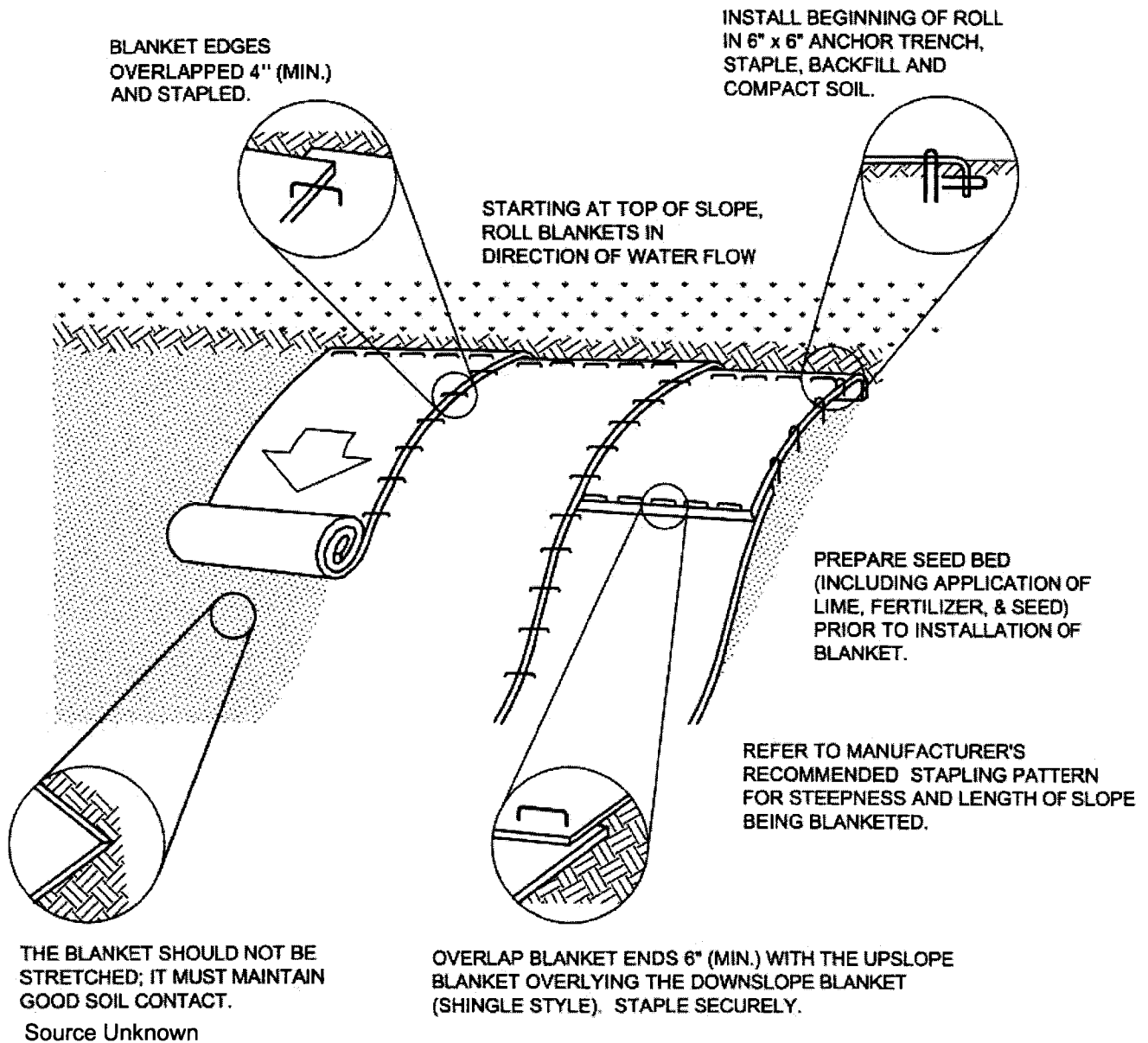

Seed and soil amendments shall be applied according to the rates in the plan drawings prior to installing the blanket.

Provide anchor trench at toe of slope in similar fashion as at top of slope.

Slope surface shall be free of rocks, clods, sticks, and grass.

Blanket shall have good continuous contact with underlying soil throughout entire length. Lay blanket loosely and stake or staple to maintain direct contact with soil. Do not stretch blanket.

The blanket shall be stapled in accordance with the manufacturer's recommendations.

Blanketed areas shall be inspected weekly and after each runoff event until perennial vegetation is established to a minimum uniform 70% coverage throughout the blanketed area. Damaged or displaced blankets shall be restored or replaced within 4 calendar days.

COMPOST FILTER SOCK - Sediment Removal Efficiency: HIGH. This device is an ABACT for HQ and EV watersheds. Compost filter socks are a type of contained compost filter berm. They consist of a biodegradable or photodegradable mesh tube filled, typically using a pneumatic blower, with a coarse compost filter media that meets certain performance criteria (e.g. hydraulic flow through rate, total solids removal efficiency, total suspended solids removal efficiency, turbidity reduction, nutrient removal efficiency, metals removal efficiency, and motor oil removal efficiency).



York County Conservation District

Compost filter socks are flexible and can be filled in place or in some cases filled and moved into position. They are especially useful on steep slopes. Heavy vegetation should be removed prior to installing the sock. Compost socks can also be used on rocky slopes if sufficient preparation is made to ensure good contact of the sock with the underlying soil along its entire length. They may also be used on pavement as a perimeter control. Socks used in this manner range in diameter from 8" to 32". **Note: The flat dimension of the sock should be at least 1.5 times the nominal diameter. Also, some settlement of the tube typically occurs after installation.** The nominal diameter of the tube is the dimension to be used for design purposes (i.e. Figure 4.2). Socks with diameters less than 12" should only be used for residential housing lots of $\frac{1}{4}$ acre or less that are tributary to a sediment basin or sediment trap.

As with other sediment barriers, filter socks should be placed parallel to contour with both ends of the sock extended upslope at a 45 degree angle to the rest of the sock to prevent end-arounds (Figure 4.1). Socks placed on earthen slopes should be anchored with stakes driven through the center of the sock (Standard Construction Detail #4-1) or immediately downslope of the sock at intervals recommended by the manufacturer. Where socks are placed on paved surfaces, concrete blocks should be used immediately downslope of the socks (at the same intervals recommended for the stakes) to help hold the sock in place.

The maximum slope length above a compost filter sock should not exceed those shown in Figure 4.2. **NOTE: Slope length is not addressed by use of multiple rows of compost socks.** The anticipated functional life of a biodegradable filter sock should be 6 months; for photodegradable socks it is 1 year. Some other types may last longer. Projects with disturbances anticipated to last longer than the functional life of a sock should plan to replace the socks periodically or use another type of BMP.

Upon stabilization of the tributary area, the filter sock may be left in place and vegetated or removed. In the latter case, the mesh is typically cut open and the mulch spread as a soil supplement. In either case, the stakes should be removed.

Filter socks using other fillers may be approved on a case-by-case basis if sufficient supporting information (including manufacturer's specs and independent test data) is provided. However, they might not qualify as ABACTs. Wherever compost socks are used, Table 4.1 should be placed on a detail sheet.

**TABLE 4.1
Compost Sock Fabric Minimum Specifications**

Material Type	3 mil HDPE	5 mil HDPE	5 mil HDPE	Multi-Filament Polypropylene (MFPP)	Heavy Duty Multi-Filament Polypropylene (HDMFPP)
Material Characteristics	Photo-degradable	Photo-degradable	Bio-degradable	Photo-degradable	Photo-degradable
Sock Diameters	12" 18"	12" 18" 24" 32"	12" 18" 24" 32"	12" 18" 24" 32"	12" 18" 24" 32"
Mesh Opening	3/8"	3/8"	3/8"	3/8"	1/8"
Tensile Strength		26 psi	26 psi	44 psi	202 psi
Ultraviolet Stability % Original Strength (ASTM G-155)	23% at 1000 hr.	23% at 1000 hr.		100% at 1000 hr.	100% at 1000 hr.
Minimum Functional Longevity	6 months	9 months	6 months	1 year	2 years
Two-ply systems					
Inner Containment Netting	HDPE biaxial net				
	Continuously wound				
	Fusion-welded junctures				
	3/4" X 3/4" Max. aperture size				
Outer Filtration Mesh	Composite Polypropylene Fabric (Woven layer and non-woven fleece mechanically fused via needle punch)				
	3/16" Max. aperture size				
Sock fabrics composed of burlap may be used on projects lasting 6 months or less.					

Filtrex & JMD

Compost should be a well decomposed, weed-free organic matter derived from agriculture, food, stump grindings, and yard or wood/bark organic matter sources. The compost should be aerobically composted. The compost should possess no objectionable odors and should be reasonably free (<1%

by dry weight) of man-made foreign matter. The compost product should not resemble the raw material from which it was derived. Wood and bark chips, ground construction debris or reprocessed wood products are not acceptable as the organic component of the mix.

The physical parameters of the compost should comply with the standards in Table 4.2. The standards contained in the PennDOT Publication 408 are an acceptable alternative.

**TABLE 4.2
Compost Standards**

Organic Matter Content	80% - 100% (dry weight basis)
Organic Portion	Fibrous and elongated
pH	5.5 - 8.0
Moisture Content	35% - 55%
Particle Size	98% pass through 1" screen
Soluble Salt Concentration	5.0 dS/m (mmhos/cm) Maximum

Filtrexx

STANDARD CONSTRUCTION DETAIL #4-1 COMPOST FILTER SOCK

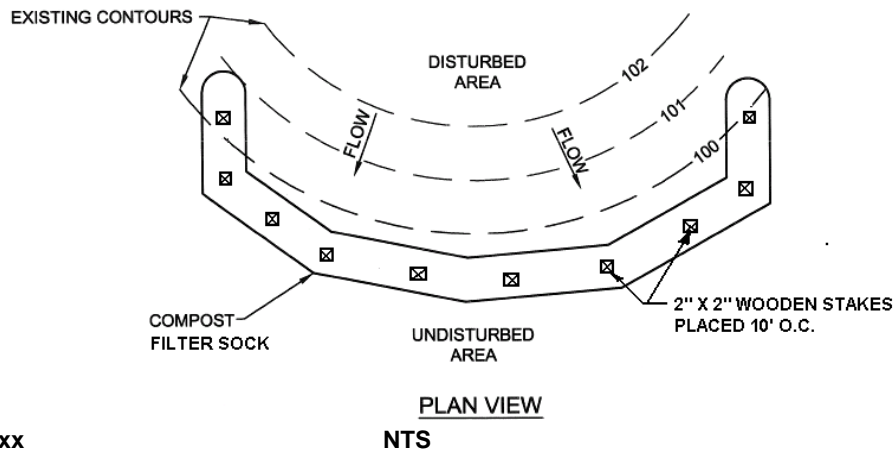
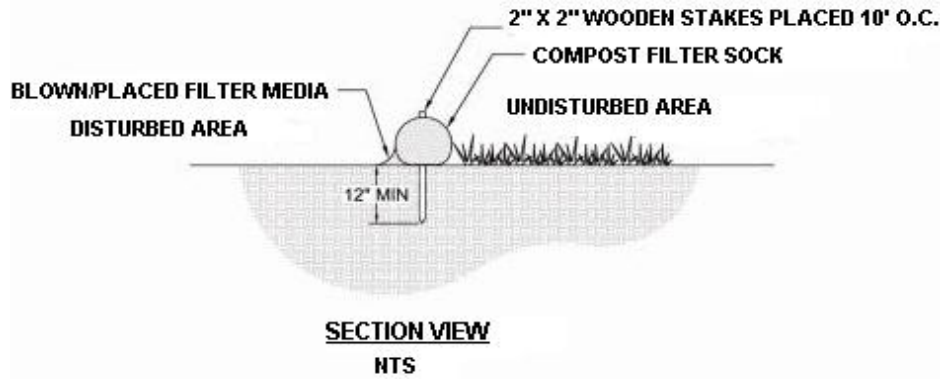

Filtrexx

Sock fabric shall meet standards of Table 4.1. Compost shall meet the standards of Table 4.2.

Compost filter sock shall be placed at existing level grade. Both ends of the sock shall be extended at least 8 feet up slope at 45 degrees to the main sock alignment (Figure 4.1). Maximum slope length above any sock shall not exceed that shown on Figure 4.2. Stakes may be installed immediately downslope of the sock if so specified by the manufacturer.

Traffic shall not be permitted to cross filter socks.

Accumulated sediment shall be removed when it reaches half the aboveground height of the sock and disposed in the manner described elsewhere in the plan.

Socks shall be inspected weekly and after each runoff event. Damaged socks shall be repaired according to manufacturer's specifications or replaced within 24 hours of inspection.

Biodegradable filter socks shall be replaced after 6 months; photodegradable socks after 1 year. Polypropylene socks shall be replaced according to manufacturer's recommendations.

Upon stabilization of the area tributary to the sock, stakes shall be removed. The sock may be left in place and vegetated or removed. In the latter case, the mesh shall be cut open and the mulch spread as a soil supplement.

FIGURE 4.2
MAXIMUM PERMISSIBLE SLOPE LENGTH ABOVE COMPOST FILTER SOCKS

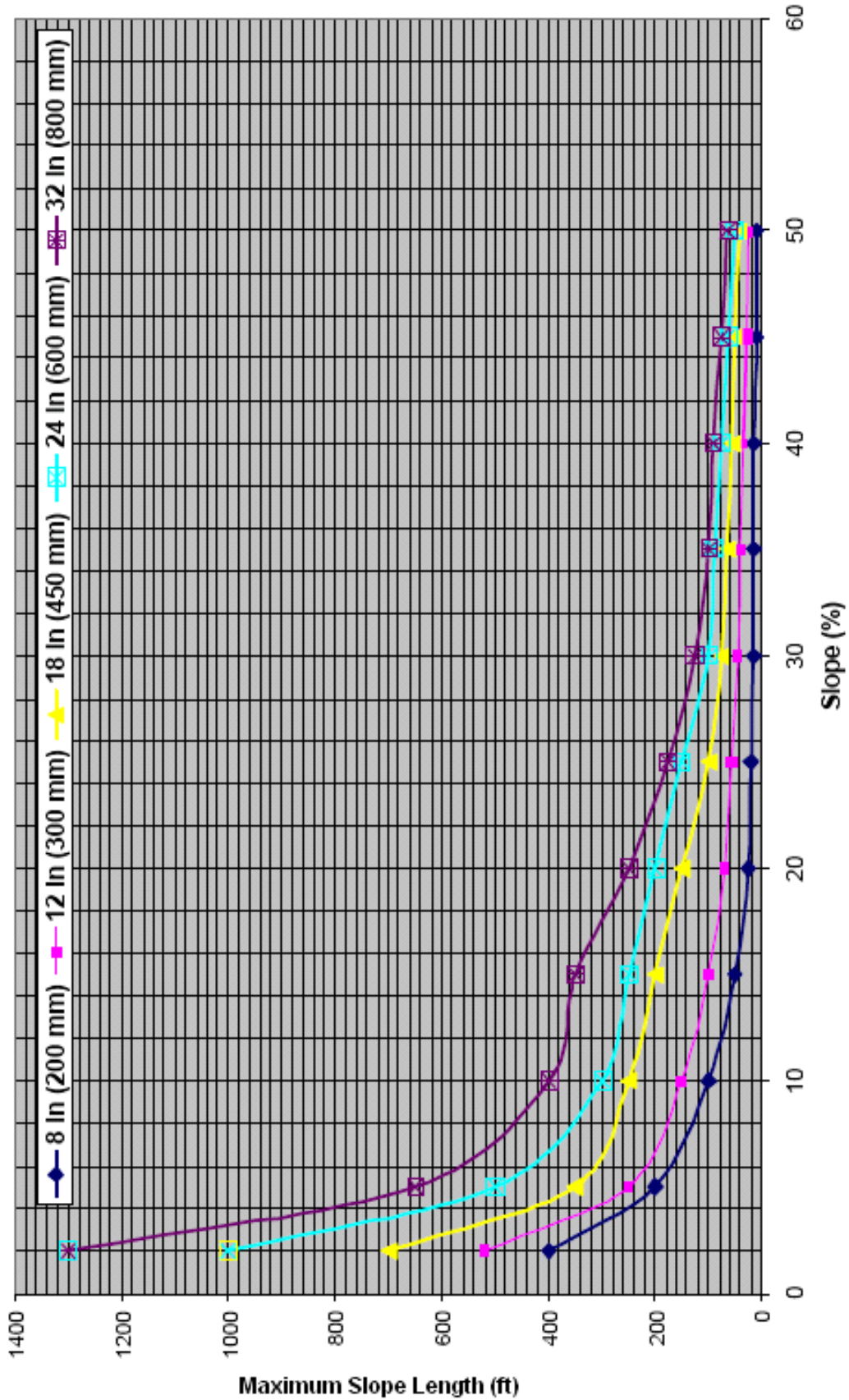

NOTE: 8" diameter socks should only be used to control small ($\leq 1/4$ acre) disturbed areas on individual house lots).

Adapted from Filtrexx

FIGURE 4.3
Maximum Permissible Slope Length above Silt Fence and Straw Bale Barriers

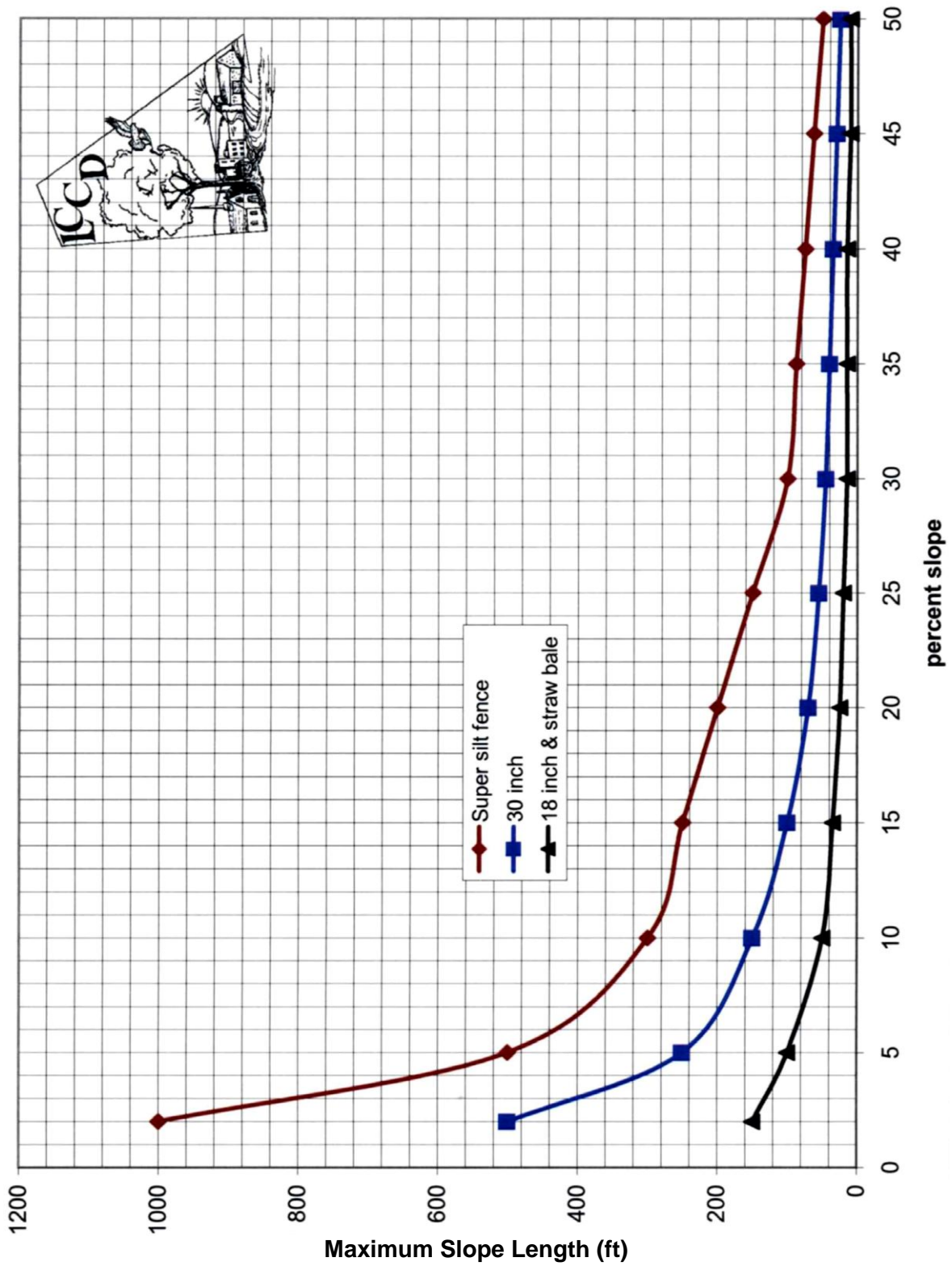

**STANDARD CONSTRUCTION DETAIL # 4-7
Standard Silt Fence (18" High)**

*STAKES SPACED @ 8' MAX.
USE 2" x 2" (± 3/8") WOOD
OR EQUIVALENT STEEL
(U OR T) STAKES

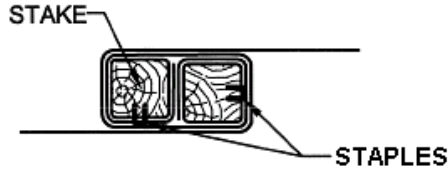

JOINING FENCE SECTIONS

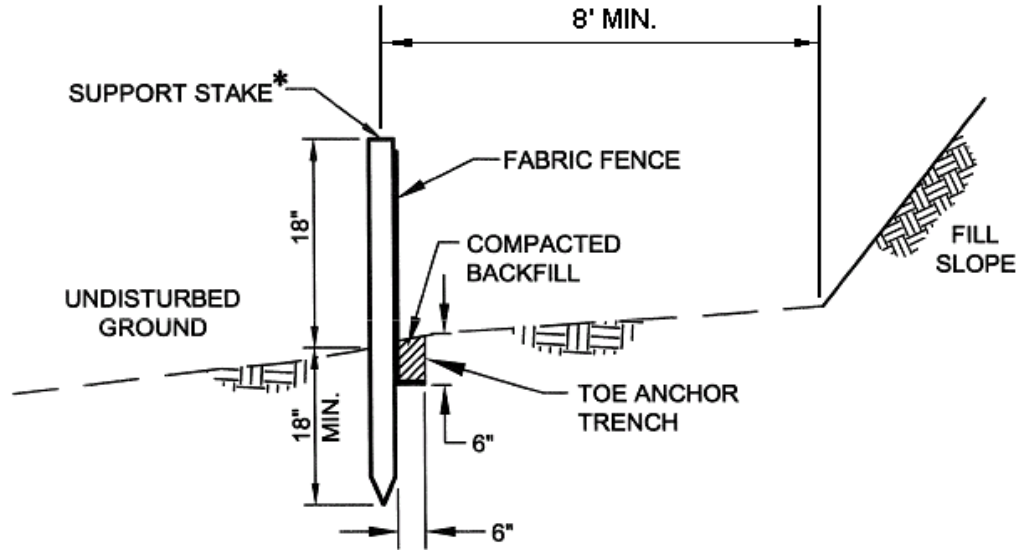

ELEVATION VIEW

PA DEP

Fabric shall have the minimum properties as shown in Table 4.3.

Fabric width shall be 30" minimum. Stakes shall be hardwood or equivalent steel (U or T) stakes.

Silt fence shall be placed at level existing grade. Both ends of the fence shall be extended at least 8 feet up slope at 45 degrees to the main fence alignment (see Figure 4.1).

Sediment shall be removed when accumulations reach half the aboveground height of the fence.

Any section of silt fence which has been undermined or topped shall be immediately replaced with a rock filter outlet (Standard Construction Detail # 4-6).

Fence shall be removed and properly disposed of when tributary area is permanently stabilized.

**STANDARD CONSTRUCTION DETAIL # 4-8
Reinforced Silt Fence (30" High)**

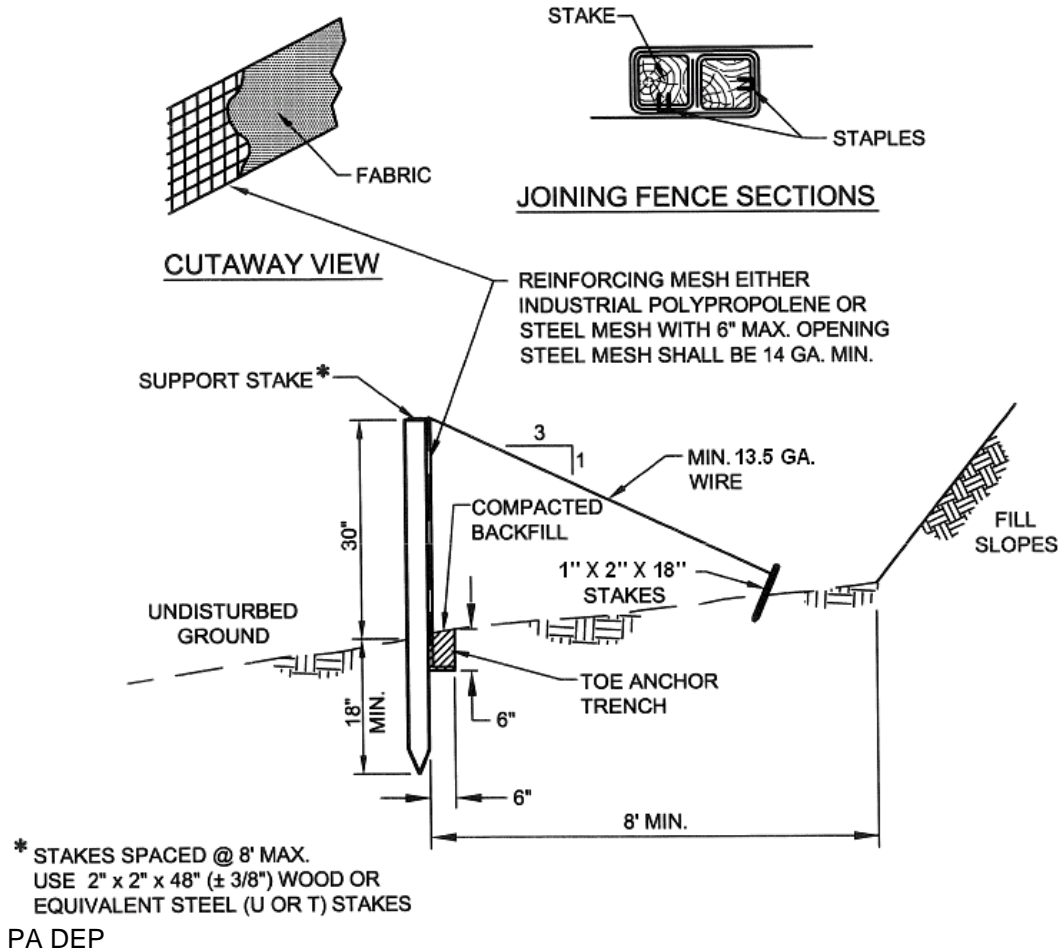

Fabric shall have the minimum properties as shown in Table 4.3.

Fabric width shall be 42" minimum. Stakes shall be hardwood or equivalent steel (U or T) stakes. An 18" support stake shall be driven 12" minimum into undisturbed ground.

Silt fence shall be installed at existing level grade. Both ends of each fence section shall be extended at least 8 feet upslope at 45 degrees to the main fence alignment (Figure 4.1).

Sediment shall be removed where accumulations reach half the aboveground height of the fence.

Any section of silt fence which has been undermined or topped shall be immediately replaced with a rock filter outlet (Standard Construction Detail # 4-6).

Fence shall be removed and properly disposed of when tributary area is permanently stabilized.

**STANDARD CONSTRUCTION DETAIL # 4-9
Silt Fence Reinforced by Staked Straw Bales**

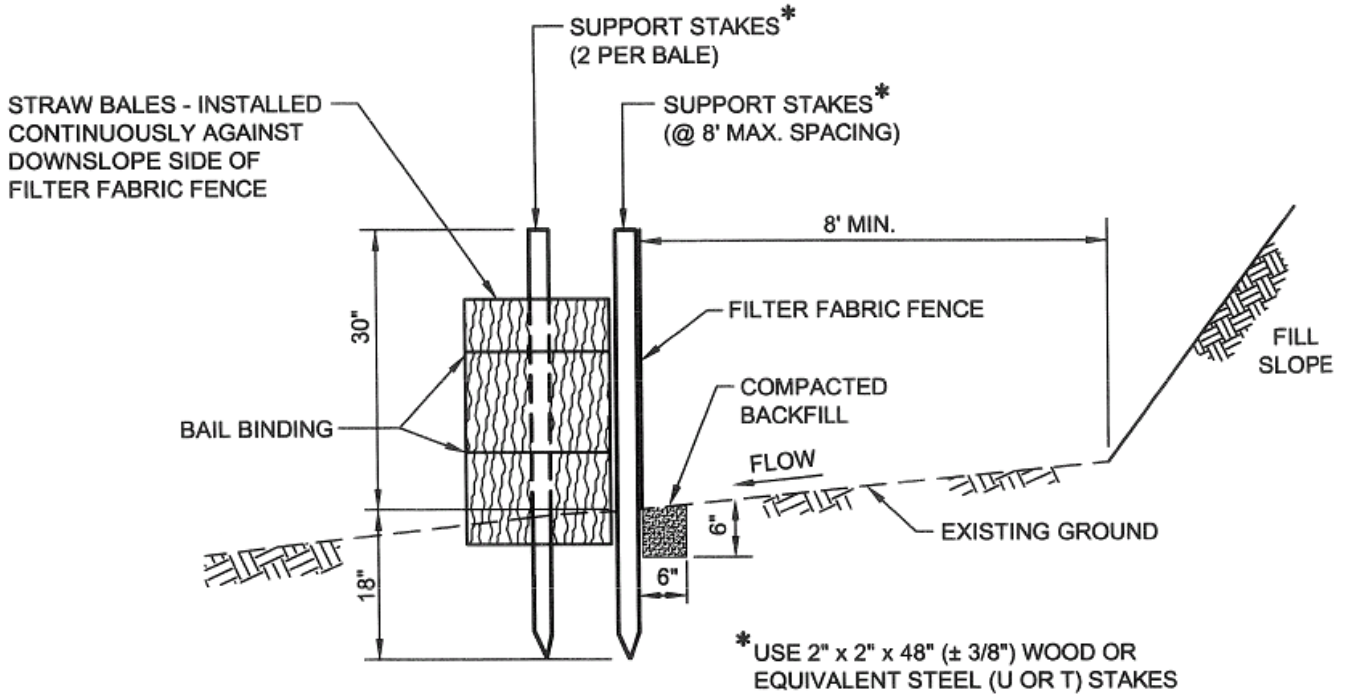

PA DEP

Fabric shall have the minimum properties as shown in Table 4.3.

This BMP is not suitable for projects lasting longer than 3 months unless bales are replaced quarterly.

Fabric width shall be 42" minimum. Stakes shall be hardwood or equivalent steel (U or T) stakes.

Silt fence shall be installed at existing level grade. Both ends of each fence section shall be extended at least 8 feet upslope at 45 degrees to the main fence alignment (Figure 4.1).

Sediment shall be removed where accumulations reach half the aboveground height of the fence.

Any fence section which has been undermined or topped shall be immediately replaced with a rock filter outlet (Standard Construction Detail # 4-6).

Fence shall be removed and properly disposed of when tributary area is permanently stabilized.

STANDARD CONSTRUCTION DETAIL # 3-16 Pumped Water Filter Bag

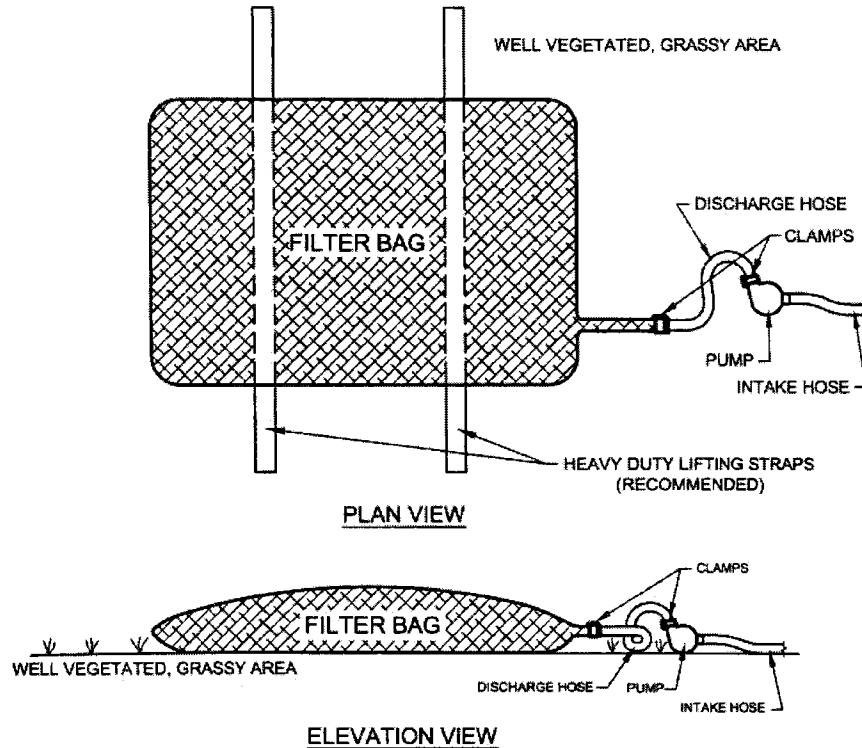

PA DEP

Low volume filter bags shall be made from non-woven geotextile material sewn with high strength, double stitched “J” type seams. They shall be capable of trapping particles larger than 150 microns. High volume filter bags shall be made from woven geotextiles that meet the following standards:

Property	Test Method	Minimum Standard
Avg. Wide Width Strength	ASTM D-4884	60 lb/in
Grab Tensile	ASTM D-4632	205 lb
Puncture	ASTM D-4833	110 lb
Mullen Burst	ASTM D-3786	350 psi
UV Resistance	ASTM D-4355	70%
AOS % Retained	ASTM D-4751	80 Sieve

A suitable means of accessing the bag with machinery required for disposal purposes shall be provided. Filter bags shall be replaced when they become ½ full of sediment. Spare bags shall be kept available for replacement of those that have failed or are filled. Bags shall be placed on straps to facilitate removal unless bags come with lifting straps already attached.

Bags shall be located in well-vegetated (grassy) area, and discharge onto stable, erosion resistant areas. Where this is not possible, a geotextile underlayment and flow path shall be provided. Bags may be placed on filter stone to increase discharge capacity. Bags shall not be placed on slopes greater than 5%. For slopes exceeding 5%, clean rock or other non-erodible and non-polluting material may be placed under the bag to reduce slope steepness.

No downslope sediment barrier is required for most installations. Compost berm or compost filter sock shall be installed below bags located in HQ or EV watersheds, within 50 feet of any receiving surface water or where grassy area is not available.

ATTACHMENT 4:

Soils Map, Soils Description, Geologic Formations Map

Sunoco - Pennsylvania Pipeline Project - Ebensburg Pump Station - Limiting Soil Characteristics

MAP UNIT SYMBOL	SOIL NAME	EASILY ERODIBLE	CUTBANKS CAVE	CORROSIVE TO CONCRETE/ STEEL	DEPTH TO SATURATED ZONE/ SEASONAL HIGH WATER TABLE	LOW STRENGTH/ LANDSLIDE PRONE	PIPING	POOR SOURCE OF TOPSOIL	HYDRIC/ HYDRIC INCLUSIONS
BpC	Berks	X	X	C			X	X	X
BpC	Blairton	X	X	C/S	X	X	X	X	X
CvD	Cookport	X	X	C/S	X	X	X	X	X
CvD	Ernest	X	X	C/S	X	X	X	X	X
LDF	Laidig	X	X	C/S	X	X	X	X	X

Actions taken to counteract soil limitations

- (1) Erodible Soils - E&S BMPs will be in place and functional prior to earth disturbance. Prompt stabilization practices will be implemented.
- (2) Cut Banks Caves -Almost all Pennsylvania soils are susceptible to caving of cut banks. Cut slopes will be stabilized as soon as possible with seed and mulch or erosion control blankets to prevent sliding. Slopes are designed to not exceed 2H:1V.
- (3) Corrosive to concrete or steel pipe - Pipes to be used on site shall be either HDPE or coated steel.
- (4) High Water Table -Should a high ground water table be encountered during construction, water will be drained away from disturbed areas to a well vegetated area or a placed compost filter sock prior to being discharged off site. Saturated soils the require compaction will be dried prior to being used on site.
- (5) Low Strength - Most of Pennsylvania soils (73%) have relatively low strength. Precautions will be taken to prevent slope failures due to improper construction practices. Soils will be evaluated during construction to determine whether additional measures will need to be taken.
- (6) Piping Tendencies -Piping is the erosion by percolating waters or seepage in layer of subsoil resulting in caving and the formation of tunnels or pipes through which the soluble or granular material is removed. Where necessary, anti-seep collars will be used to prevent piping.
- (7) Poor Topsoil -Soil amendments will be added to site soils to promote vegetative growth.

Soils Map

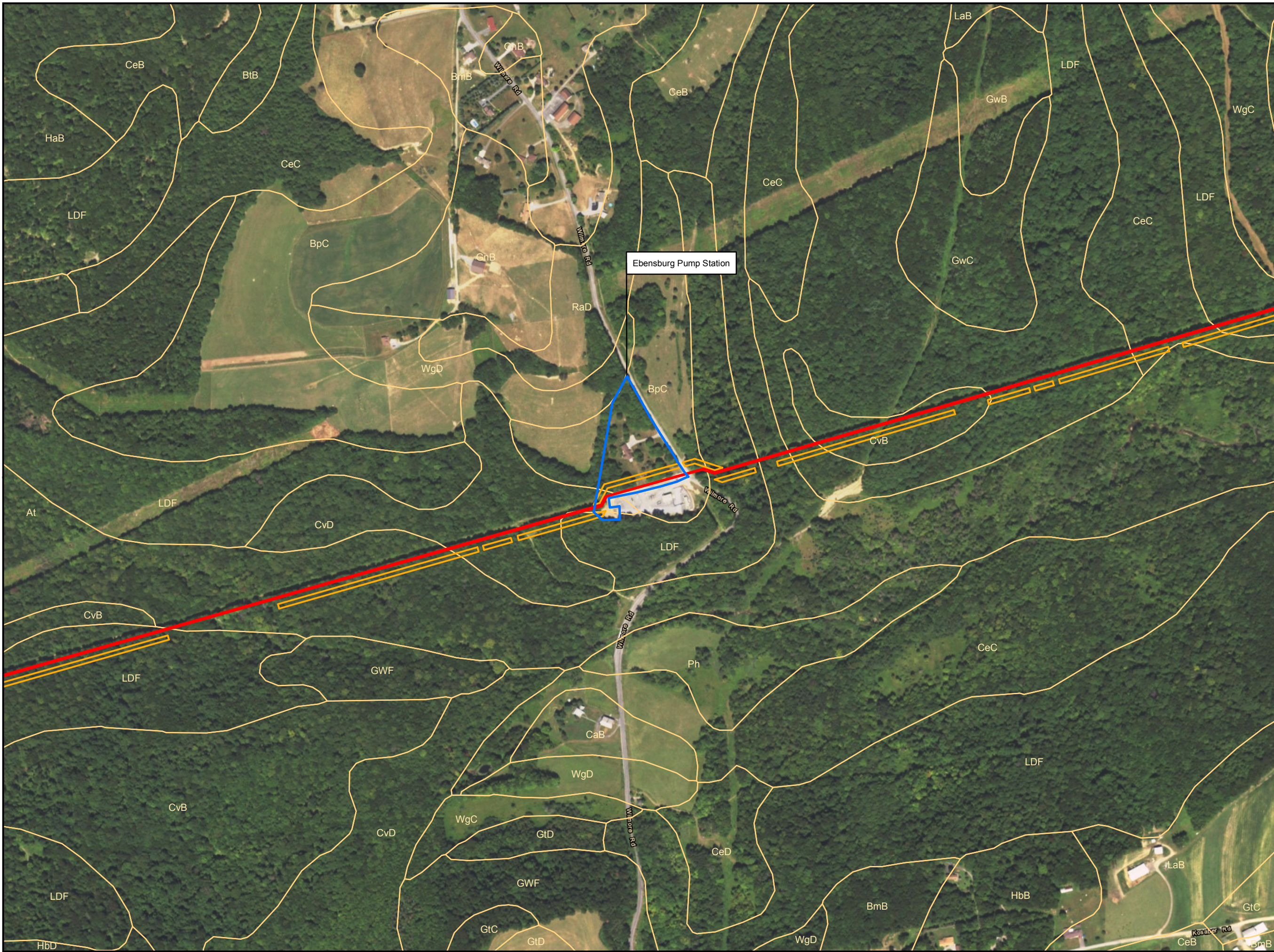

- Legend**
- Access Road
 - Alignment Centerline
 - Limit of Disturbance
 - NRCS Soils and Codes
 - Pump Station

Ebensburg Pump Station

Sheet Identifier

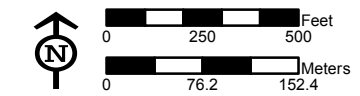
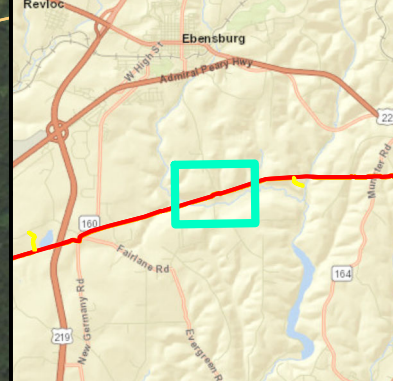

**NRCS SOILS MAP
ATTACHMENT 2
PENNSYLVANIA PIPELINE PROJECT
OCTOBER 3, 2016 ALIGNMENT
SUNOCO LOGISTICS, L.P.
CAMBRIA COUNTY, PA**



Notes:
Aerial photograph provided by ESRI's
ArcGIS Online World Imagery map service
(© 2015 ESRI and its data suppliers)

PGH_P:\GIS\SUNOCO\MARINER_EAST_2\MDX\PPP_STATIONS\PPP_PIPELINE_PUMP_STATIONS\SOILS_ESGCP_MXD_10/14/16.SP

Formations Map

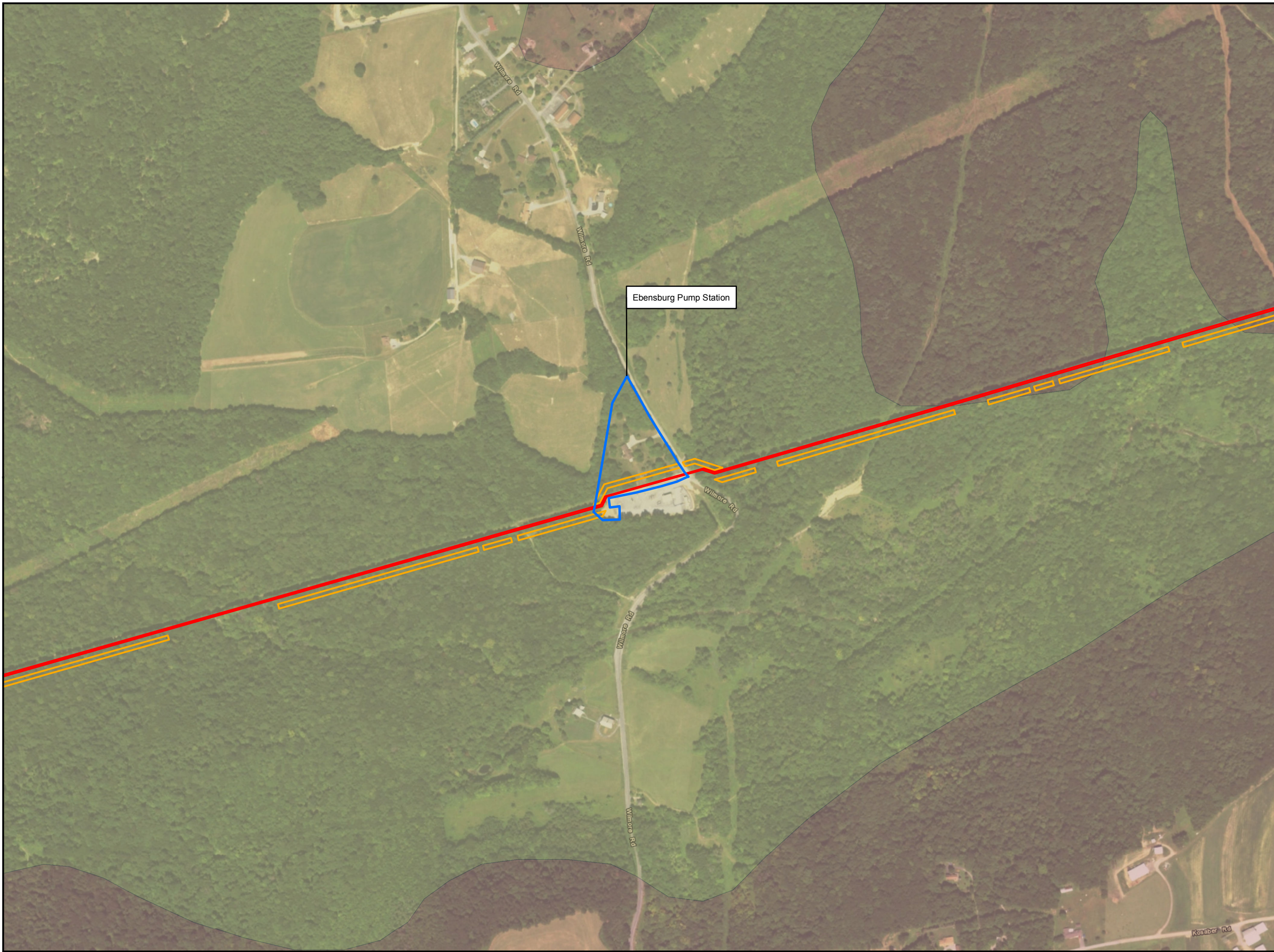

Legend

- Access Road
- Alignment Centerline
- Limit of Disturbance
- Pump Station

Geologic Units

- Casselman Formation (Pcc)
- Glenshaw Formation (Pcg)

Ebensburg Pump Station

Sheet Identifier

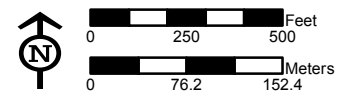
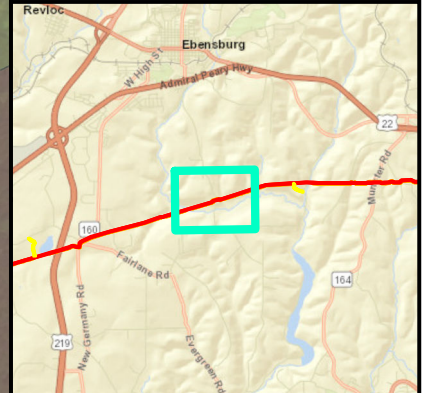

**GEOLOGIC UNIT MAP
ATTACHMENT 2
PENNSYLVANIA PIPELINE PROJECT
OCTOBER 3, 2016 ALIGNMENT
SUNOCO LOGISTICS, L.P.
CAMBRIA COUNTY, PA**



Notes:
Aerial photograph provided by ESRI's
ArcGIS Online World Imagery map service
(© 2011 ESRI and its data suppliers)

PGH_P\GIS\SUNOCO\MARINER_EAST_2\MXD\PPP_ESCGRP\PUMP_STATIONS\PPN\PIPELINE_PUMPSTATIONS_GEOLOGY_ESCGRP.MXD 10/14/16 SP