

2014 PROPOSED SUSQUEHANNA RIVER SAMPLING PLAN

WATER QUALITY STANDARDS
BUREAU OF POINT & NON-POINT SOURCE MANAGEMENT
DEPARTMENT OF ENVIRONMENTAL PROTECTION
COMMONWEALTH OF PENNSYLVANIA

March 2014

INTRODUCTION

Wide-scale, disease-related mortality of young-of-year (YOY) smallmouth bass was first documented in 2005 and again annually at varying degrees between 2006 and 2013 on the West Branch Susquehanna River, Susquehanna River, Juniata River, and various tributaries. Documented disease-related mortality of YOY smallmouth bass was lowest in 2006, 2012 and 2013 possibly due, at least in part, to higher than average surface water flow/discharge, lower than average temperatures and overall less critical or limiting conditions. Since 2010, bacterial infections resulting in lesions have also been documented in a number of warm-water streams in the Susquehanna River basin. Fish pathology studies conducted by USGS indicate there is a high degree of intersex among the smallmouth bass at some locations in the River and tributaries that may be caused by endocrine disruption. In 2009 100% of the adult fish collected on the Juniata River at Newport exhibited intersex characteristics. Endocrine disruption can also compromise fish immune systems. As a result, the distribution and concentrations of potential endocrine disrupters as well as possible causal links to the diseased fish will be investigated using an array of methods.

Routine biological sampling coupled with anecdotal observations indicates the biological community of the Susquehanna River basin includes a significant number of non-native species. Non-native species containing thiaminase (enzyme that breaks down thiamine) are known to have caused reproductive failure in some fish species. There appears to be similarities between smallmouth bass fry survival and previous cases of reproductive failure due to vitamin B1 (thiamine) deficiency. Smallmouth bass are thought to feed heavily on crawfish. Crawfish are reported to contain thiaminase (Ying and Rutledge 1975) but it is unknown if thiaminase is greater in the rusty crawfish (*Orconectes rusticus*) compared to the native species that have been displaced by this non-native species. Presently the history of the non-native rusty crawfish in the lower Susquehanna River basin is being determined through a literature review, and confirmation surveys are planned for the 2014 sampling season. Additional work is planned to examine levels of thiamine and thiaminase in crawfish, both native and non-native, and smallmouth bass.

Throughout 2012 and 2013 the Department has significantly increased its effort in studying nutrients and effects on surface waters within the Susquehanna River basin, as well as throughout the entire

Commonwealth. Excessive nutrients can cause excessive algal growth that can in turn lead to depressions of dissolved oxygen and increases in pH. Depressed oxygen levels would be a major stressor on fish. The data collected in 2012 and 2013 is currently being used in conjunction with historical nutrient data, including the Water Quality Network (WQN) Bay Loading characterization, to develop nutrient criteria and to assess trends. The 2014 study will continue to include water column and benthic substrate nutrient sampling. Additional water chemistry sampling is planned to characterize the potential for elevated or toxic levels of ammonia (NH₃) and dissolved carbon dioxide (CO₂).

Temperature is another major stressor that may contribute to the problem, especially in the Susquehanna River which is broad and shallow in many segments. During low flows the broad river area and shallow water results in more solar heating than in other major Pennsylvania rivers. Fish nursery areas in shallow backwater are especially susceptible. The Department will continue to monitor temperature along with pH, dissolved oxygen, specific conductivity and turbidity by deploying continuous instream monitors (CIMs) as well as collecting traditional discrete measurement data.

Benthic macroinvertebrates are good indicators of long term water quality and will be another focus of study. Fish will also be sampled at select locations. Past studies of the aquatic community have focused on the smallmouth bass so a more holistic assessment of the aquatic community is needed.

This 2014 Proposed Susquehanna River Sampling Plan is in part a continuation of the 2013 Plan. As results from the 2013 study become available sample sites may be modified in order to better characterize the water quality of the Susquehanna River and its tributaries. The 2012 and 2013 studies represent significantly increased efforts above and beyond historical and routine WQN sampling and surface water assessments. This has allowed the Department to not only characterize water quality on the Susquehanna River, but to begin to relate that data back to the work the Department and other agencies have done over the years to assess other surface waters. There is now a more detailed and evolving understanding of how a mix of contribution from both healthy and impaired waters affect larger river systems, as well as the relationship of historical basin assessments and associated prescribed improvements that effect water quality.

One of the major goals of this effort is not only to further develop sampling and assessment methodologies for larger surface waters, but also to provide a sound, scientifically defensible assessment of the Susquehanna River and other Pennsylvania surface waters. This plan may be modified to account for unforeseen circumstances as it is implemented.

SAMPLE LOCATIONS

The 2014 Plan will include 8-9 core large river sampling locations, including two out-of-basin controls. They are:

- Susquehanna River at Marietta
- Susquehanna River at Harrisburg
- Susquehanna River North Branch at Danville
- Susquehanna River West Branch at Lewisburg
- Juniata River at Newport
- Juniata River at Lewistown Narrows
- Juniata River at Newton Hamilton (Tentative)
- Delaware River at Trenton (Delaware control)

- Allegheny River at Franklin (Ohio control)

Additional large river sampling locations have been established. They are:

- Susquehanna River at Sunbury
- Susquehanna River at Clemson Island
- Susquehanna River at Browns Island

For large river sampling locations, the river will have water quality characterized via discrete water quality transects and divided into thirds, halves, or treated as a single homogenous water body as instream conditions warrant. Sampling will take place at one or more locations within each third or half of the river as discussed below and according to the appropriate attached protocols.

Additional locations will be established on major tributaries. They are:

- Lower Susquehanna River Mainstem Tributaries
 - Swatara Creek
 - Conodoguinet Creek
 - Shermans Creek
 - Mahantango Creek West
- Susquehanna River North Branch Tributary
 - Wyalusing Creek
- Susquehanna River West Branch Tributaries
 - Chillisquaque Creek
 - Loyalsock Creek
 - Pine Creek
 - Kettle Creek
 - Bennett Branch Sinnemahoning Creek
- Juniata River Tributaries
 - Kishacoquillas Creek
 - Jacks Creek
 - Tuscarora Creek
 - Buffalo Creek
 - Aughwick Creek
- Out-of-Basin Control Tributaries
 - Connoquenessing Creek
 - Allegheny River at Port Allegheny (Tentative)

- Youghiogheny River

Additional locations will be established and sampled parallel as part of the Department's effort to develop nutrient criteria. They are:

- Tohickon Creek (Bucks Co.)
- Red Clay Creek (Chester Co.)
- Perkiomen Creek (Montgomery Co.)
- Pine Creek (Berks Co.)
- Big Elk Creek (Chester Co.)
- Brandywine Creek (Delaware Co.)
- Goose Creek (Chester Co.)
- Indian Creek (Montgomery Co.)

Table 1 provides a comprehensive list of sample locations with corresponding sampling protocols.

CONTINUOUS INSTREAM MONITORING (CIM)

Continuous instream monitoring (CIM) of dissolved oxygen (mg/L), oxygen saturation (%), temperature (°C), specific conductance ($\mu\text{S}/\text{cm}^\circ$), and pH (SU) will be measured using YSI 6-Series Sondes or Measurement Specialties Eureka2 Sondes in three separate transects across the Susquehanna River at Harrisburg and two separate transects across, the Susquehanna River at Marietta, the Delaware River at Trenton, and the Juniata River at Newport. CIM monitoring will be performed across a single transect on the Juniata River at Lewistown Narrows, the Susquehanna River West Branch at Lewisburg, the Susquehanna River North Branch at Danville, and on the Allegheny River at Franklin. CIM will not occur at the 2013 Susquehanna River at Sunbury location. Turbidity (FNU) will be added to the Susquehanna River at Harrisburg and Marietta, the Juniata River at Newport, and Swatara Creek at Hershey. Instruments will be calibrated prior to sampling using analytical standards as detailed in the Department's CIM Protocol (Appendix A).

DISCRETE WATER QUALITY TRANSECT CHARACTERIZATION

In addition to continuous instream monitoring, discrete field measurements will be collected along transects, strategically placed in an effort to document mixing logistics. Discrete transects will be established at each sample location, and additional transects will be established at other locations to help characterize upstream/downstream tributary influences. Discrete transects will also be established to document water quality at PFBC smallmouth bass YOY sample locations. Four transects have been established at the Susquehanna River at Harrisburg location. Four transects have been established on the Juniata River from Newton Hamilton to Newport. One transect has been established at the 2013 Susquehanna River at Sunbury location, the Susquehanna River at Marietta location, the Susquehanna River West Branch at Lewisburg location, the Susquehanna River North Branch at Danville location, the Delaware River at Trenton location, and the Allegheny River at Franklin location.

Each transect should be sampled approximately every three weeks beginning April 2014 and continue through September. Transects should be sampled late-day April through about mid-June to capture what is typically the critical period for pH and during the pre-dawn/early morning hours during mid-June through September to capture what is typically the critical period for dissolved oxygen. Transect data must be collected with a reliable and calibrated meter. Calibrations and checks must be documented

TABLE 1. SUSQUEHANNA RIVER PROPOSED GENERAL SAMPLING MATRIX 2014

	Station Bold = Core Site Grey = Tentative Site WQN = Routine Water Quality Network Sampling X = Non-WQN Sampling									
		Benthic Macroinvertebrates	Fish	Algae Phase 1 Natural	Algae Phase 2 Tiles	Continuous Instream Monitoring (Summer Critical)	Water Quality Transects	Water Chemistry	Sediment	
West Branch	West Branch Sus. - Karthaus (WQN0404)	X	X	TBD		WQN	X	WQN		
	West Branch Sus. - Jersey Shore (WQN0448)	WQN	X	TBD			WQN	WQN		
	West Branch Sus. - Lewisburg (WQN0401)	X	X	X	X	SHCES ?	X	WQN	TBD	
Upper Mainstem	Susquehanna - Great Bend	?	X	TBD						
	Susquehanna - Falls	?	X	TBD						
	Susquehanna - Danville (WQN0301)	X	X	X	X	WQN	X	WQN	TBD	
Mid/Lower Mainstem	Susquehanna - Sunbury (WQN0203)	X	X				X	WQN	TBD	
	Susquehanna - Clemson Island	X	X				X	X		
	Susquehanna - Browns Island	X	X				X	X		
Juniata	Juniata - Newton Hamilton	X	X	TBD			X	X		
	Juniata - Lewistown Narrows	X	X	X		X	X	X	X	
	Juniata - Mifflin	X	X	X		TBD	X	X		
	Juniata - Newport (WQN0214)	X	X	X	X2	X	X	X	X	
Lower Mainstem	Susquehanna - Harrisburg (WQN0202)	X	X	X	X3	X	X	X	X	
	Susquehanna - Marietta (WQN0201)	X	X	X		X	X	X	X	
	Delaware - Morrisville (WQN0101)	X	X	X	X	WQN or X	X	X	X	
Out-of-Basin	Allegheny - Franklin	X	X	TBD	X	WQN	X	X	TBD	
	Allegheny - Port Allegheny (WQN0860)	X	TBD	TBD		WQN	X	WQN		
	Connequenessing - Zelenople (WQN0907)	X	X	TBD		WQN	X	X	TBD	
	Youghiogheny - Sutersville (WQN0706)	X	X	TBD		WQN	X	X	TBD	
N. Br. Trib.	Wyalusing Creek	X	X	TBD			TBD	X		
	Bennett Branch - Pennfield	?	X	TBD						
	Bennett Branch - Bennezette	?	X	TBD						
	Bennett Branch - Dents Run	?	X	TBD						
	Bennett Branch - Driftwood (WQN0439)	?	X	TBD			WQN	WQN		
	Kettle Creek - Cross Fork (WQN0459)	WQN	X	TBD		WQN	WQN	WQN		
	Pine Creek - Waterville (WQN0410)	WQN	TBD	TBD		WQN	X	WQN		
	Pine Creek - Hamilton Bottom	TBD	TBD	TBD		TBD	TBD	TBD		
	Loyalsock Creek - Loyalsockville (WQN0408)	X	X	TBD		TBD	TBD	WQN		
	Loyalsock Creek - Hillsgrove (WQN0428)	WQN	TBD					WQN		
	West Branch Tributaries	Chillisquaque Creek (Not at WQN)	X	X	TBD		TBD	TBD	X	
		Mahantango Creek West	X	X	TBD		TBD	TBD	X	
		Shermans Creek - Shermansdale (WQN0243)	WQN	X	TBD		TBD	TBD	WQN	
Conodoguinet Creek - Sample Bridge (WQN0271)		WQN	X	TBD		TBD	TBD	X		
Swatara Creek - Hershey (WQN0272)		X	X	X		X	X	X	X	
Spring Creek - Hershey		X	TBD	TBD				SCR		
Manada Creek - TBD		X	TBD	TBD		TBD	TBD	SCR		
Quittapahilla Creek - Annville (WQN0285)		X	TBD	TBD		TBD	TBD	SCR		
Swatara Creek - Harpers Tavern		X	X	TBD		X	TBD	SCR		
Little Swatara Creek - TBD		X	TBD	TBD		TBD	TBD	SCR		
Mainstem Tributaries	Swatara Creek - Swatara Gap	X	TBD	TBD		TBD	TBD	SCR		
	Kishacoquillas Creek (WQN0282)	X	X	X		X	X	X		
	Kishacoquillas Creek Tributaries - TBD		TBD	TBD		TBD	TBD	TBD		
	Aughwick Creek (WQN0249)	X	X	X		X	X			
	Jacks Creek	X	X	X		X	X	X		
	Tuscarora Creek	X	X	X		X	X	X		
	Lost Creek		TBD	TBD		TBD		TBD		
	Cocolamus Creek		TBD	TBD		TBD		TBD		
	Buffalo Creek	X	X	X		X	X	X		
	Little Juniata River - Spruce Creek (WQN0217)		TBD					WQN		
Juniata Tributaries	Frankstown Branch - Williamsburg (WQN0224)		TBD					WQN		
	Perkiomen Creek Mont. Co. (WQN0116)	TBD	X	X		X	X	X		
	Red Clay Creek Chester Co. (WQN0150)	TBD	X	X	X	X	X	X		
	Pine Creek Berks Co. (WQN0178)	TBD	X	X		X	X	X		
	Tohickon Creek Bucks Co.	TBD	X	X	X	X	X	X		
	Big Elk Creek Chester Co. (WQN0256)	TBD	X	X		X	X	X		
	Brandywine Creek Del. Co. (WQN0105)	TBD	X	X		X	X	X		
	Goose Creek - Mosteller Park	TBD	X	X		X	X	X		
	Goose Creek - Oakbourne Rd	TBD	X	X		X	X	X		
	Goose Creek - Thornbury Park	TBD	X	X		X	X	X		
Nutrient Criteria Development	Indian Creek - Bergey	TBD	X	X		X	X	X		
	Indian Creek - Rt. 63	TBD	X	X	X	X	X	X		

before and after transect data is collected. Transect points should remain consistent for each sample collection event. The first and last transect point from a shore or an island shore should be collected in what will be described as smallmouth bass YOY habitat. This is typically shallower or slowing moving water with cover near the shoreline. If a transect has a CIM on it, one discrete measurement must be collected at that point. Calibrations must be verified before first discrete sample and after last discrete sample is collected for each transect. Each discrete sample will receive a four-digit collector number and a three-digit sequence and will be entered into the Sample Information System (SIS) under the

'RIVERWORK14' Project ID. All information should be recorded on the Discrete Water Quality Monitoring Field Form (Appendix B). Attempts should be made to collect additional data to describe inconsistencies in cross-transect water quality. This could include developing additional discrete monitoring transects upstream or on upstream tributaries.

WATER CHEMISTRY

In addition to water chemistry collected for the Water Quality Network (WQN), grab samples will be collected over CIMs at each location every 3-4 weeks and be sent to the DEP lab for analysis using standard analysis code 612 (Table 2) and required bottle ware can be found in Table 3. The parameters for analysis (Table 2) include:

TABLE 2. SAC 612

Test Code	Test Description
95	Specific Conductivity @ 25.0 C
403	pH, Lab (Electrometric)
410	Alkalinity Total as CaCO ₃ (Titrimetric)
530	Total Suspended Solids
00600A	Nitrogen Total as N
00602A	Dissolved Nitrogen
00608A	Ammonia Dissolved as Nitrogen
00610A	Ammonia Total as Nitrogen
00630A	Nitrate & Nitrite, Total as Nitrogen
00631A	Nitrate & Nitrite, Dissolved as Nitrogen
00665A	Phosphorus, Total as P
00666A	Phosphorus, Total as P
00671A	Phosphorus, Ortho Dissolved
680	Carbon, Total, Organic
900	Hardness Total (Calculated)
00916A	Calcium, Total by Trace Elements in Waters & Wastes by ICP
00927A	Magnesium, Total by Trace Elements in Waters & Wastes by ICP
00929A	Sodium, Total by Trace Elements in Waters & Wastes by ICP
940	Chloride by Ion Chromatograph
945	Sulfate by Ion Chromatograph
01007A	Barium, Total by Trace Elements in Waters & Wastes by ICP
01022K	Boron, Total
01042H	Copper, Total by Trace Elements in Waters & Wastes by ICPMS
01045A	Iron, Total by Trace Elements in Waters & Wastes by ICP
01051H	Lead, Total by Trace Elements in Waters & Wastes by ICPMS
01055A	Manganese, Total by Trace Elements in Waters & wastes by ICP
01067A	Nickel, Total by Trace Elements in Waters & Wastes by ICP
01082A	Strontium, Total, by Trace Elements in Waters & Wastes by ICP
01092A	Zinc, Total by Trace Elements in Waters & Wastes by ICP
01105A	Aluminum, Total by Trace Elements in Waters & wastes by ICP
01147H	Selenium, Total by Trace Elements in Waters & Wastes by ICPMS
70300U	Total Dissolved Solids @ 180 C by USGS-I-1750
70507A	Phosphorus, Total, Orthophosphate as P
82550	Osmotic Pressure, MOS/KG
99020	Bromide by Ion Chromatography



CO₂ and NH₃ Toxicity

It has been hypothesized that the aquatic biota, including juvenile smallmouth bass, could be experiencing stressful conditions that may not necessarily be characterized through traditional nutrient enrichment targeted water chemistry monitoring. Additional stress could exist through elevated levels of instream CO₂ and NH₃ that may be toxic, especially when water temperatures are elevated, and even if pH is elevated and dissolved oxygen is depressed but not outside water quality criteria (Cravotta, 2013). The greatest potential for elevated and/or potentially toxic levels of CO₂ would occur pre-dawn, after a prolonged overnight period dominated by instream respiration as well as fungal and bacterial decay process.



Respiration produces CO₂ and in water easily dissolves to form carbonic acid (H₂CO₃) in turn depressing pH (Wurts, 2003), hence minima instream pH are typically observed early morning after the dark period dominated by respiration.



Elevated nutrients and increased temperatures increases photosynthetic activity and consequently increase the biomass of instream biota and an increase respiration. As photosynthetic activity and respiration increase daily fluctuations in pH increases resulting in more extreme early morning depressions (increased CO₂ + H₂O → H₂CO₃) as well as higher late day pH excursions. As temperatures and pH increase a greater proportion of total ammonium (NH₄) is present as toxic, un-ionized ammonia (NH₃) (Wurts, 2003).



To test this hypothesis multiple water chemistry samples will be collected across established water quality transects at locations targeting pre-dawn and late-evening hours during select periods of elevated water temperatures, elevated pH (> 8.5 SU) and depressed dissolved oxygen (< 5.0 mg/l). Periods will be characterized by moderate to base flow conditions that persist for at least a period of approximately 3-4 weeks beginning June through July, when juvenile smallmouth bass are relegated to near-shore YOY habitat. Samples will be collected at points and include those at near-shore points as well as main channel points. Water chemistry samples will be collected using standard analysis code 612 with additional tests added for Total Inorganic Carbon (TIC) and Dissolved Inorganic Carbon (DIC). CIMs will be deployed in both near-shore habitats as well as main channel points to track continuous temperature, pH, dissolved oxygen and specific conductivity. See Table 3 for required bottle ware and preservatives.

TABLE 3. BOTTLE WARE AND PRESERVATIVES FOR SELECT WATER CHEMISTRY

SAC 612	
BOL (Microcystins)	1 - 40 ml VOA – Frozen , AMPLE HEADSPACE
General Chemistry	2 - 500 ml – ICE
Total N+P	1 - 125 ml - H2SO4
Dissolved N+P	1 - 125 ml (Filtered) - H2SO4
Dissolved General Chem.	1 - 125 ml (Filtered) – ICE
TOC	2 - 40 ml VOA - H2SO4, NO HEADSPACE
Microcystin	
Microcystin	1 - 40 ml VOA – ICE
DIC and TIC	
DIC and TIC	2 - 40 ml VOA - ICE, NO HEADSPACE

Table 4 provides a comprehensive list of sample location with corresponding water quality monitoring protocols.

DISCHARGE

All sample locations that are not co-located with a USGS gaging station will have discharge data collected and calculated for each routine water chemistry sample collected according to the Department’s Instream Comprehensive Evaluation (ICE) Surveys Methods Manual (http://www.depweb.state.pa.us/portal/server.pt/community/water_quality_standards/10556/2013_assessment_methodology/1407203).

BENTHIC MACROINVERTEBRATES

Benthic macroinvertebrates will be collected in three separate transects at all core lower mainstem Susquehanna River locations including Sunbury, Harrisburg, Marietta and at least two additional locations including Clemson Island and Browns Island. Large river samples will be collected August through September and again in November if conditions permit. Samples will be collected at tributary locations in November. Benthic macroinvertebrates will be collected in two separate transects at other large river sampling sites. Sample results from within each transect could subsequently be composited

TABLE 4. PROPOSED WATER CHEMISTRY/QUALITY SAMPLING MATRIX 2014

	Station Bold = Core Site Grey = Tentative Site WQN = Routine Water Quality Network Sampling X = Non-WQN Sampling	Continuous Instream Monitoring (Summer Critical)	Turbidity	Water Quality Transects	Transect Documentation	Water Chemistry	CO2 and NH3 Toxicity
West Branch	West Branch Sus. - Karthaus (WQN0404)	WQN		X	SIS	WQN	
	West Branch Sus. - Jersey Shore (WQN0448)			WQN		WQN	
	West Branch Sus. - Lewisburg (WQN0401)	SHCES ?		X	SIS	WQN	
Upper Mainstem	Susquehanna - Great Bend						
	Susquehanna - Falls						
	Susquehanna - Danville (WQN0301)	WQN		X	SIS	WQN	
Mid/Lower Mainstem	Susquehanna - Sunbury (WQN0203)			X	SIS	WQN	
	Susquehanna - Clemson Island			X	SIS	X	
	Susquehanna - Browns Island			X	SIS	X	
Juniata	Juniata - Newton Hamilton			X	SIS	X	
	Juniata - Lewistown Narrows	X	TBD	X	SIS	X	
	Juniata - Mifflin	TBD		X	SIS	X	
	Juniata - Newport (WQN0214)	X	X	X	SIS	X	X
Lower Mainstem	Susquehanna - Harrisburg (WQN0202)	X	X3	X	SIS	X	X
	Susquehanna - Marietta (WQN0201)	X	X2	X	SIS	X	X
Out-of-Basin	Delaware - Morrisville (WQN0101)	WQN or X		X	SIS	X	X
	Allegheny - Franklin	WQN		X	SIS	X	
	Allegheny - Port Allegheny (WQN0860)	WQN		X	SIS	WQN	
	Connequenessing - Zelenople (WQN0907)	WQN		X	SIS	X	
	Youghiogheny - Sutersville (WQN0706)	WQN		X	SIS	X	
N. Br. Trib.	Wyalusing Creek			TBD	.XLS	X	
West Branch Tributaries	Bennett Branch - Pennfield						
	Bennett Branch - Bennezette						
	Bennett Branch - Dents Run						
	Bennett Branch - Driftwood (WQN0439)				WQN		WQN
	Kettle Creek - Cross Fork (WQN0459)	WQN			WQN		WQN
	Pine Creek - Waterville (WQN0410)	WQN			X	SIS	WQN
	Pine Creek - Hamilton Bottom	TBD			TBD		TBD
	Loyalsock Creek - Loyalsockville (WQN0408)	TBD			TBD		WQN
	Loyalsock Creek - Hillsgrove (WQN0428)						WQN
Mainstem Tributaries	Chillisquaque Creek (Not at WQN)	TBD		TBD	.XLS	X	
	Mahantango Creek West	TBD		TBD	.XLS	X	
	Shermans Creek - Shermansdale (WQN0243)	TBD		TBD	.XLS	WQN	
	Conodoguinet Creek - Sample Bridge (WQN0271)	TBD		TBD	.XLS	X	
	Swatara Creek - Hershey (WQN0272)	X	X	X	SIS	X	X
	Spring Creek - Hershey						SCR
	Manada Creek - TBD	TBD		TBD	.XLS	SCR	
	Quittapahila Creek - Annville (WQN0285)	TBD		TBD	.XLS	SCR	
	Swatara Creek - Harpers Tavern	X		TBD	.XLS	SCR	
	Little Swatara Creek - TBD	TBD		TBD	.XLS	SCR	
Juniata Tributaries	Swatara Creek - Swatara Gap	TBD		TBD	.XLS	SCR	
	Kishacoquillas Creek (WQN0282)	X		X	.XLS	X	
	Kishacoquillas Creek Tributaries - TBD	TBD		TBD	.XLS	TBD	
	Aughwick Creek (WQN0249)	X		X	.XLS		
	Jacks Creek	X		X	.XLS	X	
	Tuscarora Creek	X		X	.XLS	X	X
	Lost Creek	TBD					TBD
	Cocolamus Creek	TBD					TBD
	Buffalo Creek	X		X	.XLS	X	
	Little Juniata River - Spruce Creek (WQN0217)						WQN
Frankstown Branch - Williamsburg (WQN0224)						WQN	
Nutrient Criteria Development	Perkiomen Creek Mont. Co. (WQN0116)	X		X	.XLS	X	
	Red Clay Creek Chester Co. (WQN0150)	X		X	.XLS	X	
	Pine Creek Berks Co. (WQN0178)	X		X	.XLS	X	
	Tohickon Creek Bucks Co.	X		X	.XLS	X	
	Big Elk Creek Chester Co. (WQN0256)	X		X	.XLS	X	
	Brandywine Creek Del. Co. (WQN0105)	X		X	.XLS	X	
	Goose Creek - Mosteller Park	X		X	.XLS	X	
	Goose Creek - Oakbourne Rd	X		X	.XLS	X	
	Goose Creek - Thornbury Park	X		X	.XLS	X	
	Indian Creek - Bergey	X		X	.XLS	X	
	Indian Creek - Rt. 63	X		X	.XLS	X	

and subsampled to appreciate the community and selected indices across the entire width of the sites. This is a slight modification from the Department's RBP benthic sampling methodology outlined in the ICE protocol that would otherwise be a complete width sample composite.

Benthic macroinvertebrates will be collected at tributary locations in November according to the Department's RBP benthic sampling methodology outlined in the ICE protocol.

FISH

Fish surveys will be conducted at three separate 500-meter transects at all core lower mainstem Susquehanna River locations including Sunbury, Harrisburg, Marietta and at least two additional locations including Clemson Island and Browns Island. Fish surveys will be conducted at two separate transects at other large river sample locations. Surveys will be conducted beginning late-June through early-October as conditions permit. In addition fish health will be characterized at all fish sample sites. Fish surveys will be conducted using a method similar to that which was employed in 2013, which is currently under development. Fish surveys to be conducted at wadeable tributaries locations will be performed using the Department's "Wadeable Semi-Quantitative Fish Sampling Protocol for Streams" (Appendix E).

MUSSELS

Mussels were collected at approximately 14 large river sites in 2013. Mussel collections are not currently proposed for the Susquehanna River basin in 2014, with the exception of a few locations to be determined within the Swatara Creek basin.

ALGAE

Phase 1

Phase 1 algal sampling will be conducted during the summer low-flow critical condition. Antecedent rainfall and river stage conditions will be monitored throughout the summer and sampling will take place at least two weeks after any potentially scouring flows.

Phase 1 algal samples will be collected in three separate transects at all core lower mainstem Susquehanna River locations including Sunbury, Harrisburg, and Marietta. Phase 1 algal samples will be collected in two separate transects at other large river sampling locations.

Large river Phase 1 algal samples will be collected using a modification of the Department's Periphyton Standing Crop and Species Assemblages Field Protocol (Appendix C). Figure 1 represents a single large river Phase 1 station of which there are three per sampling location (right near shore, left near shore, center). CIMs will be placed in each third of the river at each sampling location. Additionally, periphyton will be collected from 27 rocks – three rocks at each of the red triangles in Figure 1 - and composited to provide benthic biomass and cellular nutrient values for each transect (A, B and C).

A near shore habitat will be selected that is visually representative with regard to substrate size, shading, and periphyton standing crop. Each transect is divided into thirds and three rocks are randomly collected within each third of the transect (n=9 per transect). The nine rocks along each transect are composited. When retrieving rocks the collector should reach down at the collection location and pick a rock by touching it lightly with a finger while refraining to look at the streambed. If the rock is a suitable size for periphyton sampling (will accept a 2 inch diameter seal), it is placed in an empty dishpan for transport to the PEP sampler. If the substrate is too small to obtain an adequate PEP sampler seal or too large to remove (large boulder, bedrock), the collector should retrieve the closest rock to the selected rock that is of suitable size for sampling. Dishpans can be covered to protect samples from sunlight and desiccation prior to scraping.

Labels for all processed samples should include station ID (Susquehanna West), date, subsample type (Chl-a, CN, P, Algal ID) and subsample volume. Total surface area for each transect (ea. 9 rocks x $18.1 \text{ cm}^2 = 162.9 \text{ cm}^2$), total transect volumes, Chl-a subsample volumes, total composite volume, CN and P subsample volumes and algal ID volumes are recorded on the Periphyton Survey Data Sheet and labeled as described in Table 5.

QA – One replicate subsample will be collected for Chl-a, CN, P (transect A, B, or C) and Algal ID (composite) for every 10 stations sampled (10%) to examine subsample variability. Replicate information should be on the field form to the right of the routine volume information and marked with an R.

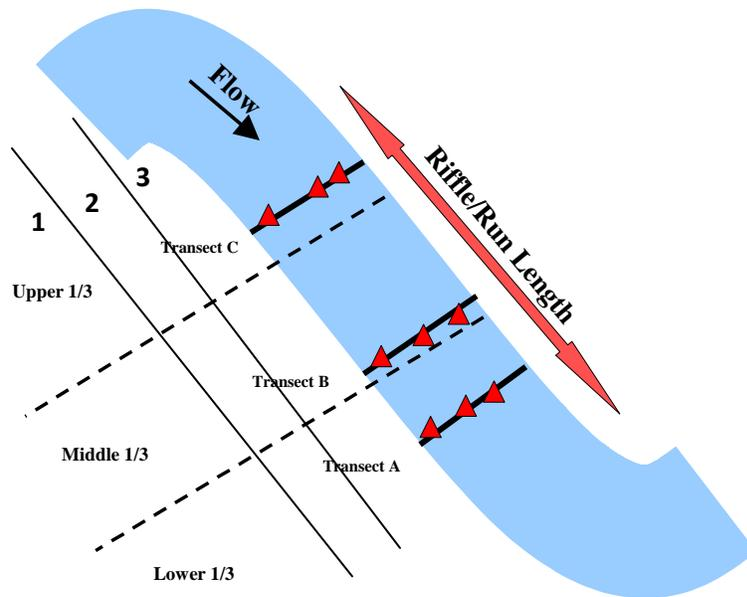

Figure 1. Diagram for intensive Phase 1 sampling that will take place in three sections across the river (only one section is shown in figure).

A series of analyses will be run on the composited slurry at each site to quantify microbial biomass, P-storage, and nutrient content (C, N, P, and Poly-P). Algal biomass will be estimated for each sample by concentrating subsamples onto filter membranes. The chlorophyll concentration in each filter will be determined using an organic extraction procedure (50:50 mixture of 90% Acetone to Dimethyl sulfoxide (DMSO)); chlorophyll-a concentrations will subsequently be measured using a standard fluorometric technique (Carrick et al. 1993a). Standard analytical techniques will be used to measure nutrients in stream biofilm samples. Total carbon and nitrogen concentrations will be measured via combustion on subsamples concentrated onto Whatman glass-fiber filters (n=90) using a Carlo-Erba CN analyzer (Horneck and Miller 1998). Total P concentrations in the biofilm material will be measured using the persulfate digestion, where liberated soluble reactive P (as PO_4^{-3}) will be measured colorimetrically using a spectrophotometer (method 365.1, USEPA 1997, 2002). Polyphosphate concentrations (Poly-P) in biofilms material will be measured by heating samples at 100°C for 60 minutes, thereby liberating PO_4^{-3} from the condensed, inorganic phosphate compounds that can occur in either cyclic, linear, or cross-linked bonds with oxygen (Fitzgerald and Nelson 1966; Harold 1966); this material will then be analyzed using the spectrophotometric method described above.

Algal Taxonomic Composition

Algal taxonomic composition will be measured using a stratified enumeration technique with a Leica DMR research microscope (Carrick and Schelske 1997; Carrick and Steinman 2001). Periphyton taxonomic composition will be determined from composite samples. The samples will be counted following a double-blind procedure, whereby the analyst does not have prior knowledge of the sample identity nor will they be involved in the sample collection.

To enumerate cells, samples will be mixed and injected into Palmer-Maloney counter chambers (0.1 ml) from which $>1,000$ cells are counted in each sample ($<4\%$ counting error assuming Poisson

Statistics). The procedure is as follows. First, the entire chamber is scanned for 15 minutes to gain familiarity with the flora present in the sample. Then, the entire chamber is counted at 100x magnification in order to accurately enumerate larger algal species (half chambers are counted for samples with extremely high cell densities). Last, random fields are counted at 400x magnification in order to estimate the abundance of smaller, more numerous algal cells. In most cases, organisms are identified to the species or generic level, but most diatoms are placed into categories based on their general morphology and relative size (e.g., Naviculoid, Cymbelloid and Gomphonemoid). Diatom species are enumerated using a specialized set of techniques as described below. Cyanobacterial filaments are enumerated and converted to cell numbers using an estimate for the average number of cells per filament as determined for a subset of organisms encountered (5-10 filaments per sample). The regular geometric figure that best describes the shape of each taxon will be used to calculate its average biovolume in μm^3 (Carrick and Steinman 2001). The biomass of all individuals encountered is calculated by multiplying the average biovolume of each taxon by its cellular abundance; the product is expressed in biomass per unit area of stream bottom assuming a specific density of 1 g/cm^3 . The occurrence (abundance and biomass) of dominant taxa belonging to the five algal phyla present in these samples (Bacillariophyta, Chlorophyta, Cyanobacteria, Euglenophyta, and Rhodophyta) are summed, and these data are subsequently used to assess nutrient thresholds.

Diatom taxonomic composition will be enumerated from permanent slides prepared using a standard nitric acid digestion and mounting procedure (Patrick and Reimer 1966). Random fields are counted at 1000x magnification until >400 frustules are enumerated (~5% counting error assuming Poisson Statistics). The diatoms are identified to their lowest taxonomic category (species, or variety), and the taxon-specific abundances are tabulated and expressed in cells/cm².

Phase 2

Phase 2 algae will be collected at 6 large river sample locations including Susquehanna River at Harrisburg, Susquehanna River North Branch at Danville, Susquehanna River West Branch at Lewisburg, Juniata River at Newport, Delaware River at Morrisville and Allegheny River at Franklin. Phase 2 algae will also be collected at nutrient criteria development sites including Red Clay Creek (Chester Co.), Tohickon Creek (Bucks Co.) and Indian Creek (Montgomery Co.).



Figure 2. Example Clay tiles to be used as artificial substrate in Phase 2. Left photo taken day of deployment, right photo after 14-days growth

Phase 2 algae sampling requires the deployment of concrete blocks with three unglazed ceramic tiles fixed to each block with silicon adhesive. The block and tile samplers are deployed instream in late-May/early-June at sites with CIMs. The samplers are deployed on day '0' with the concrete block perpendicular to flow and the tiles parallel to flow. The first tile is harvested on day '14', the second on day '28' and the third on day '42'. A duplicate sampler will be deployed on day '14' at select sites. Tiles from duplicate samplers will be harvested on day '28', '42' and '56'. The timing of tile harvest should temporally overlap Phase 1 sampling. Water chemistry grab samples using SAC 612 will be collected over the sampler each day tiles are harvested. Tiles will be analyzed for algal biomass and cellular nutrients, chlorophyll, and algal taxonomic composition consistent with Phase 1 samples.

TABLE 5. BOTTLE WARE AND PRESERVATIVES FOR SELECT ALGAL SAMPLES

Algal Samples	
Artificial Tile Samples to Central Michigan University	1- 125 ml bottle for (C, N) from 20 ml composite slurry - ICE then -80 Freezer
	1 - 125 ml bottle to contain 100 ml composite slurry for ID's - 5 ml Formaldehyde
	1 - GF Filter for Chl a from 2 ml composite slurry - ICE then -80 Freezer
	1 - GFF Whatman Filter for Add. Pig. from 2 ml composite slurry - Ice then -80 Freezer
	1 - 0.2 um Filter for Phos from 2 ml composite slurry - Ice then -80 Freezer
Natural Substrate Samples to Central Michigan University	1- 125 ml bottle for (C, N) from 20 ml composite slurry - ICE then -80 Freezer
	1 - 125 ml bottle to contain 100 ml composite slurry for ID's - 5 ml Formaldehyde
	1 - GF Filter for Chl a from 2 ml composite slurry - ICE then -80 Freezer
	1 - GFF Whatman Filter for Add. Pig. from 2 ml composite slurry - Ice then -80 Freezer
	1 - 0.2 um Filter for Phos from 2 ml composite slurry - Ice then -80 Freezer
Natural Substrate Samples to Third Party Facility	1- 125 ml bottle for (C, N) from 20 ml composite slurry - ICE then -80 Freezer
	1 - 125 ml bottle to contain 100 ml composite slurry for ID's - 5 ml Formaldehyde
	1 - GF Filter for Chl a from 2 ml composite slurry - ICE then -80 Freezer
	1 - GFF Whatman Filter for Add. Pig. from 2 ml composite slurry - Ice then -80 Freezer
	1 - 0.2 um Filter for Phos from 2 ml composite slurry - Ice then -80 Freezer
Natural Substrate Samples to DEP BOL	1 - GF Filter for Chl a from 2 ml composite slurry - ICE then -80 Freezer
	1 - 125 ml bottle to contain 100 ml composite slurry for ID's - 5 ml Formaldehyde
Natural Substrate Samples to USGS Wellsboro	1 - 500 ml bottle for Fatty Acid of final rock scrapings - Ice then -80 Freezer

FATTY ACID ANALYSIS STUDY

Algal samples collected from approximately 10 to 20 established locations will be submitted to the USGS Wellsboro Laboratory for fatty acid analysis. Preliminary studies have shown that fatty acid composition of the periphyton and biofilm change as a result of environmental conditions (Honeyfield, personal communication). This study will attempt to utilize the fatty acid composition as a surrogate for speciation of algal communities to identify changes in algal communities as instream P and N concentrations increase.

SEDIMENT

The Department will sample at least 12 locations for streambed sediment during the spring of 2013 (approximately mid-May to early June, or when the smallmouth bass begin to spawn). Analysis for the following parameters will be completed for sediment:

- Hormones
- Organic wastewater compounds
- Currently-used pesticides
- Historical pesticides
- PCBs
- Metals

Collected samples will then be sent to the appropriate USGS laboratory or DEP BOL to be analyzed. Sediment will be collected from at least 5 depositional zones in the sample area. Samples will be collected with stainless steel scoops, homogenized in stainless steel bowls, and sieved through 2 mm stainless steel sieves. Metals samples will be collected with plastic equipment. They will then be placed in 500 mL amber glass jars for analysis. Samples to be tested for pesticides will be placed in 1 L clear glass jars. Samples to be tested for metals will be placed in 500 mL plastic bottles. One duplicate will be collected for every 12 sites.

Collection will occur during fish spawning in the spring and again in late summer, during the peak “stress” period, most likely at the same sites. Since problems with smallmouth bass are thought to originate with the young of the year population, this may help determine if emerging contaminants are present where fish are spawning. It will also serve as valuable information regarding the presence, absence, and concentrations of emerging contaminants in our river systems. See the “Susquehanna River Proposed Sampling Matrix 2013” at the beginning of this report for proposed sampling locations.

PASSIVE WATER SAMPLES

Passive water samplers (polar organic chemical integrative samplers [POCIS] and semipermeable member devices [SPMD]) will be deployed at 12+ locations in the Susquehanna River basin to sample water columns for pesticides, polychlorinated biphenyls (PCBs), polybrominated diphenyl ethers (PBDEs), polycyclic aromatic hydrocarbons (PAHs), organic wastewater indicator compounds, pharmaceuticals, hormones, and total estrogenicity. These devices will be deployed by Department staff in late summer, during the peak “stress” period, and retrieved approximately 30 days later. Extracts will be mailed to the appropriate USGS laboratory for analysis. One blank device for every four locations will be collected. Lab blanks will also be provided. Based partially upon the results of this study, samplers will be deployed again in May-June 2014, corresponding with SMB spawning. It is hoped that this part of the study will help determine the extent to which emerging contaminants are infiltrating the Susquehanna basin. See the “Susquehanna River Proposed Sampling Matrix 2013” at the beginning of this report for proposed sampling locations.

HERBICIDE/PESTICIDE SAMPLING @ WATER QUALITY NETWORK (WQN) STATIONS

Pesticide sampling (Table 6) will occur at five WQN stations between March 1, 2014 and September 30, 2014. Six monthly samples, four “high flow” (stormwater) samples, and one blank will be collected at each site.

Sampling Locations

- Susquehanna River at Harrisburg – WQN 202 (USGS sampling)
- Susquehanna River at Sunbury – WQN 203 (USGS sampling)
- Susquehanna River at Marietta – WQN 201 (SRBC sampling)
- Juniata River at Newport – WQN 214 (SRBC sampling)

- Delaware River at Trenton – WQN 101 (control – USGS sampling)

These five WQN stations overlap the same locations that passive sampler/sediment collection is planned. Collecting at these locations may help determine if pesticides are present in the water column and at what concentrations throughout the year. Samples will be sent to the USGS National Water Quality Laboratory for analysis using USGS lab schedule 2001, which includes the following:

Table 6. Pesticide parameters.

Name	Name	Name
2,6-Diethylaniline	Diazinon	p,p'-DDE
2-Chloro-4-isopropylamino-6-amino-s-triazine {CIAT}	Diazinon-d10 (surrogate)	Parathion
Acetochlor	Dieldrin	Parathion-methyl
Alachlor	Disulfoton	Pebulate
alpha-HCH	EPTC	Pendimethalin
alpha-HCH-d6 (surrogate)	Ethalfuralin	Phorate
Atrazine	Ethoprophos	Prometon
Azinphos-methyl	Fipronil	Propachlor
Benfluralin	Fipronil sulfide	Propanil
Butylate	Fipronil sulfone	Propargite
Carbaryl	Fonofos	Propyzamide
Carbofuran	Lindane	Simazine
Chlorpyrifos	Linuron	Tebuthiuron
cis-Permethrin	Malathion	Terbacil
Cyanazine	Metolachlor	Terbufos
Dacthal	Metribuzin	Thiobencarb
Desulfinylfipronil	Molinate	Tri-allate
Desulfinylfipronil amide	Napropamide	Trifluralin

FISH TISSUE

Fish tissue will be collected as per the increased frequency of every two years for major river sites. Tributary collections will continue at a frequency of every five years. Additional Susquehanna River sampling will occur in early spring 2014 to coincide with the smallmouth bass spawn. The additional spring 2014 samples will be submitted as specific organ samples for pesticide, PCB, and metals analysis. By correlating with the spawn, we may be able to determine contaminate levels in organs that could affect developing embryos and potentially translate to young-of-the-year abnormalities.

THIAMINE

Thiamine content of eggs, muscle and liver will be determine from approximately 150 smallmouth bass collected from the Susquehanna River and 15 additional control fish. In addition, thiaminase activity in native crawfish and non-native rusty crawfish will be determined with the method of Honeyfield et al. (2010).

Thiamine deficiency has been shown to cause adverse neuromuscular signs and mortality in reared fish consuming diets lacking thiamine, or high amounts of thiaminase, an enzyme that breaks down thiamine (Halver, 1989; NRC 2011). Thiamine is an essential dietary nutrient which cannot be synthesized by fish and is required within the Krebs cycle and for the production of ATP (Agyei-Owusu and Leeper 2009). Thiamine pyrophosphate (TPP) is the active form of thiamine (coenzyme) required in enzymatic reactions in cells throughout the body including brain, liver and muscle whereas the metabolic importance of thiamine monophosphate (TP) is less well defined (Gubler, 1991).

The concept that thiamine deficiency may be linked with reproductive failure in wild fish was unheard of prior to mid-1990s (Fitzsimons 1995; Fisher et al. 1996). Honeyfield et al. (2005) demonstrated that Lake trout *Salvelinus namaycush* fed either a diet low in thiamine containing bacterial thiaminase or diets containing Alewife *Alosa pseudoharengus*, known to harbor thiaminase, produced low egg thiamine and significant fry mortality. The resulting clinical signs of the fry were similar to that observed in wild fish in the Great Lakes, NY Finger Lakes and Baltic Sea. (Fisher et al. 1996; Marcquenski and Brown 1997; Norrgren et al. 1998).

Mortality of newly hatched salmonid fry, between hatch and swim-up prior to exogenous feeding, was related to egg thiamine concentrations. Eggs containing < 1.5 nmol/g have high likelihood of overt fry mortality; while egg total thiamine concentrations > 1.5 and < 4.0 nmol/g have been linked to secondary effects of low thiamine (Honeyfield et al. 2005, 2008b). Secondary effects due to low total thiamine, (sum of T, TP and TPP) include adverse effects on growth, vision, predator avoidance, prey capture and immune function, all of which can reduce or prevent recruitment into the fishery (Brown et al. 2005b; Carvalho et al. 2009; Fitzsimons et al. 2009; Ottinger et al. 2012). For Small-mouth bass the relationship between egg thiamine and survival has not been determined however, this investigation will begin to elucidate the relationship.

REFERENCES

- Agyei-Owusu, K., and F.J. Leeper. 2009. Thiamin diphosphate in biological chemistry: analogues of thiamin diphosphate in studies of enzymes and riboswitches. FEBS Journal 276: 2905-2916.
- Carrick, H.J., F.J. Aldridge, and C.L. Schelske. 1993a. Wind influences phytoplankton biomass and composition in a shallow, productive lake. Limnology and Oceanography 38: 1179-1192.
- Carrick, H.J., and C.L. Schelske. 1997. Have we underestimated the importance of phototrophic picoplankton in productive waters? Limnology and Oceanography 42:1613-1621.
- Carrick, H.J., and Steinman, A.D. 2001. Variation in periphyton biomass and species composition in Lake Okeechobee, Florida (USA): Distribution of algal guilds along environmental gradients. Archiv für Hydrobiologie. 152: 411-438
- Carvalho, P. S. M., Tillitt, D. E., Zajicek, J. L., Claunch, R. A., Honeyfield, D. C., Fitzsimons, J. D., and Brown, S. B. 2009. Thiamine deficiency effects on the vision and foraging ability of lake trout fry. Journal of Aquatic Animal Health 21: 315-325.
- Cravotta, Charles A. III. 2013. Water Temperature, Streamflow, and Dissolved Gas Dynamics Relating to Ecology, Distress, and Disease of Smallmouth Bass in Susquehanna River. Susquehanna River Basin Commission, 2013 Susquehanna Water Science Forum PowerPoint Presentation.
- Fisher, J. P., Fitzsimons, J. D., Combs, G. G. and Spitzbergan, J. M. 1996. Naturally occurring thiamine deficiency causing reproductive failure in Finger Lakes Atlantic salmon and Great Lakes trout. Transactions of American Fishery Society 125: 167-178.
- Fitzsimons, J. D. 1995. The effect of B-vitamins on a swim-up syndrome in Lake Ontario lake trout. Journal of Great Lakes Research 21 (Supplement 1):286-289.
- Fitzsimons, J.D., Brown, S. B., Fodor, G., Williston, B., Brown, L., Moore, K., Honeyfield, D. C., and Tillitt, D. E. 2009. Influence of thiamine deficiency on lake trout larval growth, foraging, and predator avoidance. Journal of Aquatic Animal Health 21: 302-314.
- Fitzgerald, G.P., and T.C. Nelson 1966. Extraction and enzymatic analyses for limiting or surplus phosphorus in algae. Journal of Phycology 2: 32-37.
- Gubler, C. J. 1991. Thiamine. Pages 233-280. In Machlin, L. J. editor. Handbook of vitamins, second edition. Marcel Dekker, New York.
- Harold, F.M. 1966. Inorganic polyphosphates in biology: Structure, metabolism, and function. Microbiology and Molecular Biology Reviews 30: 772-794.
- Halver J.E. 1989. Fish nutrition. Academic Press, San Diego, CA.
- Honeyfield, D. C., J. W. Hanes, L. Brown, C. E. Kraft and T. P. Begley 2010. Comparison of thiaminase activity in fish using the radiometric and 4-nitrothiophenol colorimetric methods. Journal Great Lakes Research 36 (4): 641-645.
- Honeyfield, D. C., Hinterkopf, J. P., Fitzsimons, J. D., Tillitt, D. E., Zajicek J. L., and Brown, S. B. 2005. Development of thiamine deficiencies and early mortality syndrome in lake trout by feeding experimental and feral fish diets containing thiaminase. Journal of Aquatic Animal Health 17:4-12.

- Horneck, D.A. and R.O. Miller. 1998. Determination of total nitrogen in plant tissue. CRC Press, New York.
- Patrick, R., and Reimer, C. 1966. Diatoms of the United States, Volume I. Academy of Natural Sciences, Philadelphia, PA.
- Marcquenski, S. V., and Brown, S. B.. 1997. Early mortality syndrome in the Great Lakes. Pages 135–152 in R. M. Rolland, M. Gilbertson, and R. E. Peterson, editors. Chemically induced alterations in functional development and reproduction in fishes. SETAC, Pensacola, Florida.
- National Research Council (NRC), 2011. Nutrient requirements of fish and shrimp. Committee on Animal Nutrition, National Academies Press, Washington D.C.
- Norrgren, L., Amcoff, P., Börjeson, H., and Larsson, P. O. 1998. Reproductive disturbances in Baltic fish: A review. In McDonald, G., Fitzsimons, J., and Honeyfield, D. C. (Eds). Early life stage mortality syndrome in fishes of the Great Lakes and Baltic Sea. American Fisheries Society, Bethesda, MD. pp 8-17.
- Ottinger, C. A., Honeyfield, D. C., Densmore, C. L., and Iwanowicz, L. R. 2012. Impact of thiamine deficiency on T-cell dependent and T-cell independent antibody production in post-yearling lake trout (*Salvelinus namaycush*). Journal of Aquatic Animal Health, 24:4, 258-273.
- U.S. Environmental Protection Agency. 1997. Volunteer Stream Monitoring: A Methods Manual. EPA-841-B-97-003. U.S. Environmental Protection Agency. 2002. National Water Quality Inventory: 2000. Report, U.S. Environmental Protection Agency Report EPA-841-R-02-001 Washington, D.C.
- Ying, L.C. and J. E. Rutledge J.E. 1975. Some biochemical properties of the hepatopancreatic tissue from red crayfish (*Procambarus clarkii*). Freshwater Crayfish 2: 173.
- Wurts, W.A. 2003. Daily pH cycle and ammonia toxicity. World Aquaculture, 34(2): 20-21.

Appendix A

CONTINUOUS INSTREAM MONITORING FIELD METHODS

January, 2013

Continuous Instream Monitoring Field Methods

January, 2013

Prepared by:

Dustin Shull & Josh Lookenbill
PA Department of Environmental Protection
Bureau of Point and Non-Point Source Management
11th Floor: Rachel Carson State Office Building
Harrisburg, PA 17105

Acknowledgments

The authors appreciate the support, technical contributions, and advice of USGS in the preparation of this document.

Disclaimer

This document has been reviewed in accordance with PA Department of Environmental Protection policy and approved for publication. Mention of trade names or commercial products does not constitute endorsement or recommendation for use.

Executive Summary

The Pennsylvania Department of Environmental Protection (PADEP) Division of Water Quality Standards (DWQS) uses continuous instream monitors to assess the quality of Pennsylvania's streams. Most instream monitoring configurations include at least four parameters: water temperature, specific conductance, pH, and dissolved oxygen data. Monitors can also be configured to measure additional properties, such as turbidity, water stage, and/or fluorescence. Sensor data are valuable for a variety of purposes including but not limited to, characterizing baseline physiochemical stream conditions, describing seasonal and diel fluctuations, and documenting potential violations to water quality criteria. These data are also used in conjunction with flow measurements and chemical analyses of grab samples to estimate chemical loads. Sensors that are used to measure water quality field parameters require careful field observation, cleaning, and calibration procedures. The resulting data requires systematic actions for the computation and publication of final records.

This protocol provides guidelines for site and monitor selection, sensor inspection and calibration methods, and field maintenance procedures. Many of these criteria and procedures were developed from and mirror the USGS Guidelines and Standard Procedures for Continuous Water Quality Monitors: Station Operation, Record Computation, and Data Reporting manual (Wagner et al., 2006)

Introduction

Water quality parameters are dynamic, necessitating frequent and repeated measurements to adequately characterize variations in quality. When the time interval between repeated measurements is adequately small, the resulting water quality record can be considered continuous. A device that measures water quality in this way is called a continuous water quality monitor. These monitors have sensors and recording systems to measure physiochemical water quality field parameters at discrete time intervals and at discrete locations. Operation of a water quality monitor provides a record of water quality that can be processed and reported. The water quality data provides a record of changes in water quality that also can serve as the basis for computation of constituent loads at a given site. Data from the sensors also can be used to estimate other constituents if a significant correlation (typically through regression analyses) can be established.

The vast majority of continuous monitoring of water quality field parameters takes place in Pennsylvania's lotic surface waters which may vary significantly in size, clarity, chemical composition, and biological production. Procedures for continuous monitoring in pristine, headwater streams differ from those in large, impacted rivers. Continuous monitoring in impacted environments can be challenging because of rapid biofouling from microscopic and macroscopic

organisms, corrosion of electronic components from salts, and wide ranges in values of field parameters associated with changing weather.

Water temperature and conductivity are true physical properties of water bodies, whereas Dissolved Oxygen (DO) and pH are concentrations, and turbidity is an expression of the optical properties of water. For the purposes of this protocol, all of the sensor values recorded by the monitors are referred to as field parameters. Sensors also are available to measure other field parameters, such as oxidation-reduction potential, water stage, ammonia, nitrate, chloride, and fluorescence. In addition to the measured field parameters, some monitors include algorithms to report calculated parameters, such as specific conductance, total dissolved solids, and percentage of DO saturation. Calculated parameters can be useful; however, consideration for the potential error in the algorithms should be taken into account. Sensor technology broadens the variety of measurable chemical constituents and reduces the limits of detection. As a result, continual progress is being made to improve applications and refine quality-control procedures.

Purpose and Scope

This protocol provides basic guidelines and procedures for use by DWQS personnel in site/monitor selection, field maintenance and calibration of continuous water quality monitors, record computation, review, and data reporting. This protocol details the primary technique used by DWQS for deploying and servicing continuous instream monitors. This protocol highlights basic guidelines that may need to be modified to meet local environmental conditions. Data management procedures provided in this protocol are designed to offer basic guidelines and may need to be manipulated to suit other purposes and different software. In-depth knowledge of equipment operation and familiarity with the watershed are imperative in the data evaluation process. Examples of the application of scientific judgment in the evaluation of data records are discussed and are, by necessity, site specific.

Monitor Deployment

Major considerations in the design of a continuous instream monitoring station include site selection, monitor selection, monitor configuration, and sensor selection. Sensor and site selection are guided by the purpose of monitoring and the data objectives. The main objective in the placement of the sensors is the selection of a stable, secure location that is representative of the aquatic environment.

Site Selection

The main factors to consider in selecting a water quality monitoring site are the purpose of monitoring and the data quality objectives. All other factors used in the site selection process must be balanced against these two key factors. Defining the purpose of monitoring includes making

decisions about the field parameters to be measured, the period and duration of monitoring, and the frequency of data collection. More site-specific considerations in monitor placement include site-design requirements, monitor-installation type, physical constraints of the site, and servicing requirements.

Once the purposes of monitoring and data-quality objectives are defined, balancing the numerous considerations for placement of a continuous water quality monitoring system still can be difficult. Obtaining measurements representative of the water body usually is an important data quality objective. The optimum site consideration for achieving this objective is placing the sonde in a location that best represents the water body being measured. Thus, an optimal site is one that permits sensors to be located at a point that best represents the section of interest for the aquatic environment being monitored.

Cross-section variability and upstream influences are major factors for site selection. Cross-section surveys of field parameters must be made to determine the most representative location for monitor placement. A site must not be selected without first determining that the data-quality objective for cross-section variability will be met. Sufficient measurements must be made at the cross section to determine the degree of mixing at the prospective site under different flow conditions and to verify that cross-section variability at the site does not exceed that needed to meet data-quality objectives. Additional cross-section measurements must be made after equipment installation to ensure that the monitor installation is representative of the stream during all seasons and hydrographic flow conditions (Wagner et al., 2006).

Some aquatic environments may present unique challenges for optimal site location. Lateral mixing in large rivers often is not complete for tens of miles downstream from a tributary or outfall. Turbulent streamflow may aid in mixing, but turbulence can create problems in monitoring field parameters, such as DO or turbidity. A location near the streambank may be more representative of local runoff or affected by point-source discharges upstream, whereas a location in the channel center may be more representative of areas farther upstream in the drainage basin. Large streams and rivers usually are monitored from the downstream side of bridge abutments, assuming that safety hazards and other difficulties can be reduced or overcome.

The best location for a monitoring site is often one that is best for measuring surface-water discharge. Although hydraulic factors in site location must be considered, it is more important to consider factors that affect water quality conditions. The same hydraulic factors that must be considered when selecting a specific site for measuring discharge in a channel also should be considered in selecting a water quality monitoring location. Both purposes require a representative site that approaches uniform conditions across the entire width of the stream.

The measurement point in the vertical dimension also needs to be appropriate for the primary purpose of the monitoring installation. The vertical measurement point can be chosen for low-,

base-, or high-flow conditions; if bed movement or sensor location during low flow is a problem, consideration should be given to moving the sensors along a bridge. For a medium to small streams with alternating pools and riffles, the best flow and mixing occurs in the riffle portion of the stream; however, if flooding changes the locations of shoals upstream from the monitoring site, the measurement point may no longer represent the overall water quality characteristics of the water body. Streams subject to substantial bed movement can result in the sensors being lost or located out of water following a major streamflow event, or at a point no longer representative of the flow. A site may be ideal for monitoring high flow but not satisfactory during low flows.

Assessment of a site also is dependent on fouling potential, ease of access, and susceptibility to vandalism. The configuration and placement of water quality monitoring sensors in cold regions require additional considerations in order to obtain data during periods of ice formation. Overall, a monitoring site should be safe and accessible, meet minimum depth requirements of the equipment, avoid vandalism, and be characteristic of the entire stream. It may be necessary to reconnoiter the site under several flow conditions before a determination is made.

Monitor Selection

According to Wagner et al., 2006, the selection of a water quality monitor involves four major interrelated elements: (1) the purpose of the data collection, (2) the type of installation, (3) the type of sensor deployed at the installation, and (4) the specific sensors needed to satisfy the accuracy and precision requirements of the data-quality objectives. DWQS uses a wide variety of instream monitors; however these monitors are all designed to work with DWQS's preferred monitor configuration which eliminates the need to consider the type of installation (element number 2 above).

Sensors are available as individual instruments or as a single combined instrument that has several different sensors in various combinations. For clarity in this protocol, a sensor is the fixed or detachable part of the instrument that measures a particular field parameter. A group of sensors configured together commonly is referred to as a sonde. A sonde typically has a single recording unit or electronic data logger to record the output of multiple sensors. The term monitor refers to the combination of sensor(s) and the recording unit or data logger (Wagner et al., 2006). The most widely used water quality sensors in monitoring installations are water temperature, conductivity, DO, pH, turbidity, and water stage. These sensors are the focus of this protocol.

Monitor Configuration

The monitor configuration preferred by DWQS is an internal-logging, combined sensor and recording monitor that is entirely immersed and requires no external power. Power is supplied by conventional batteries located internally, and sensor data are stored within the sonde on nonvolatile recording devices. The monitor is placed inside a well vented schedule 80 Poly Vinyl

Chloride (PCV) shroud attached to two form stakes with carabineers and a steel cable (Figure 1). The form stakes are driven into the sediment paralleled to stream flow. In this configuration, the stakes act as a primary and secondary anchor for the monitor. Smaller monitors are also configured in this style, however shrouds are smaller and may only have one form stake anchor based on stream flow characteristics (Figure 2). In both small and large monitor configurations, equipment is covered by large rocks for protection and concealment. Figure 3 illustrates the standard instream configuration for DWQS.

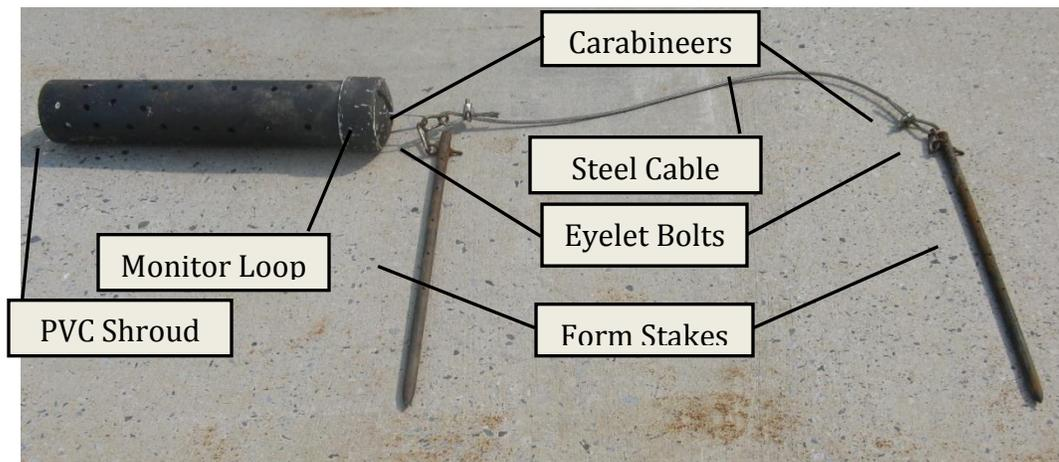

Figure 1. The preferred deployment configuration for larger monitors (YSI 6920/ Manta 2); with two rebar/form stakes used as sediment anchors. Cables and carabineers are attached to stakes using 1/4 in. eyelet bolts. Once attached, the bolt threads are stripped to avoid backing out.

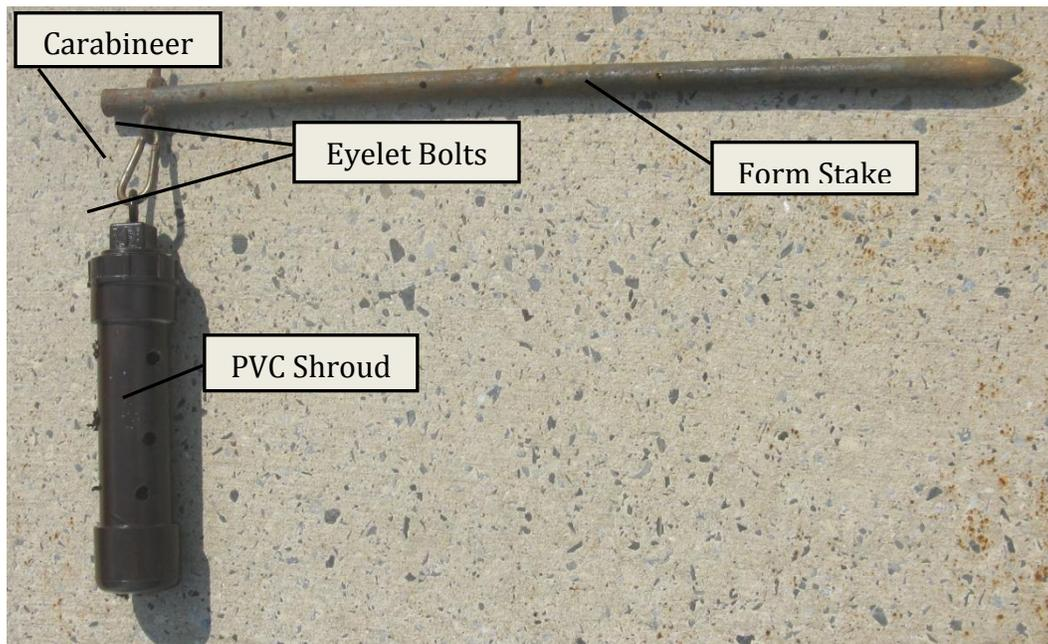

Figure 2. Deployment configuration for smaller monitors (HOBO Conductivity/Temperature Logger/Solinst Levelogger).

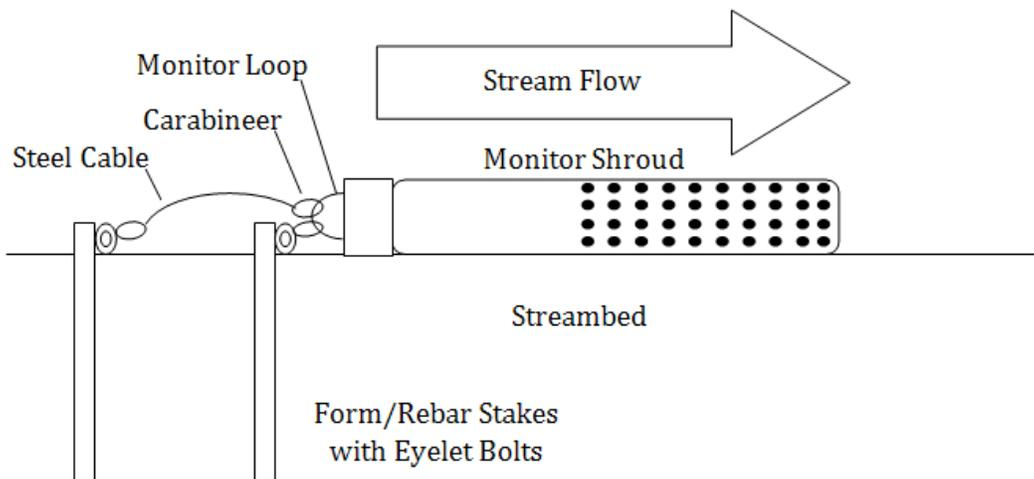

Figure 3. The standard in-stream configuration for monitors operated by DWQS. Large, but manageable, rocks (not shown in figure) are placed around the monitor for stability, concealment, and protection.

The primary advantages of the internal-logging configuration are that AC power or large batteries and shelters are not needed. As a result, the upfront cost associated with emplacement is greatly reduced and mobility of the monitors is increased. Some disadvantages to this configuration include the lack of telemetry and solar panels which increases the need for regular service visits for maintenance and data retrieval. Additional monitor configurations are discussed in Wagner et al., 2006.

Sensor Selection

Types of Sensors

Sensors are available for continuous measurement of many field parameters and chemical constituents, but six of the most commonly used sensors are water temperature, specific conductance, DO, pH, turbidity, and water stage. Common concepts and calibration procedures are described in this protocol, but manufacturers' instructions and recommendations should be followed closely. DWQS utilizes the above sensors most frequently. Sensors should be used with

caution as they may not provide sufficient information on calibration criteria, data-correction criteria, and maximum allowable limits. If a sensor is used for which these criteria have not been specified, quality-assurance data must be collected to define and apply quality-control (Wagner et al., 2006).

Water Temperature

Water temperature affects density, solubility of constituents (such as oxygen in water), pH, specific conductance, the rate of chemical reactions, and biological activity in water. Continuous water quality sensors usually measure temperature with a thermistor, which is a semiconductor having resistance that changes with temperature. Thermistors are reliable, accurate, and durable temperature sensors that require little maintenance and are relatively inexpensive. The preferred water temperature scale for most scientific work is the Celsius scale. Modern thermistors can measure temperature to plus or minus 0.1°C, but accuracy should be verified with the manufacturer (Wilde, 2006).

Specific Conductance

Electrical conductivity is a measure of the capacity of water to conduct an electrical current and is a function of the types and quantities of dissolved substances in water. As concentrations of dissolved ions increase, conductivity also increases. Specific conductance is the temperature specific calculation of conductivity expressed in units of microsiemens per centimeter (Radtke et al., 2005). The DWQS measures and reports specific conductance in microsiemens per centimeter ($\mu\text{S}/\text{cm}$) at 25 °C. Specific conductance measurements can be good surrogate for total dissolved solids and total ion concentrations, but there is no universal linear relation between total dissolved solids (TDS) and specific conductance. A relation between specific conductance and constituent concentration must be determined for each site (Radtke et al., 2005). In many circumstances, the amplitude and variability of specific conductance is not sufficient to predict other constituent concentrations (such as TDS) within the stream. Therefore, it is important to note that TDS measurements from monitors are calculated from conductivity and are not always accurate or reliable.

Monitoring systems used by the DWQS usually contain automatic temperature compensation circuits to compensate specific conductance to 25 °C. This can be verified by checking the manufacturer's instruction manual. Most modern sensors are designed to measure specific conductance in the range of 0–2,000 $\mu\text{S}/\text{cm}$ or higher. Specific conductance sensors are reliable, accurate, and durable but are susceptible to fouling from aquatic organisms and sediment.

pH

The pH of a solution is a measure of the effective hydrogen-ion concentration. Solutions having a pH below 7 are described as acidic, and solutions with a pH greater than 7 are described as basic or alkaline. Dissolved gases, such as carbon dioxide, hydrogen sulfide, and ammonia, affect pH. Degasification (for example, loss of carbon dioxide) or precipitation of a solid phase (for example, calcium carbonate) and other chemical, physical, and biological reactions may cause the pH of a water sample to change appreciably soon after sample collection (Ritz and Collins, 2008).

The electrometric pH-measurement method, using a hydrogen-ion electrode, commonly is used in continuous water quality pH sensors. A correctly calibrated pH sensor can accurately measure pH to ± 0.2 pH unit; however, the sensor can be scratched, broken, or fouled easily. If flow rates are high, the accuracy of the pH measurement can be affected by streaming-potential effects (Ritz and Collins, 2008).

Dissolved Oxygen

Dissolved oxygen (DO) in streams is produced by diffusion with the atmospheric oxygen and photosynthetic productivity. DO often drives chemical reactions within and above the substrate and is critical for the survival of aquatic organisms. Stream DO concentrations usually range from 2 to 10 milligrams per liter (mg/L). DO is also reported as percent saturation. DO saturation will decrease with increasing water temperature, and increase with increasing atmospheric pressure. Supersaturation is often related to nutrient (nitrogen and phosphorus) enrichment, which often occurs in streams during low-flow conditions. Saturated oxygen levels are also related to increased gradients, both natural and artificial. Instream DO may be depleted by inorganic reactions or biological decomposition. DO solubility is also dependent on salinity as well as temperature and barometric pressure. DO in waters that have specific conductance values $>2,000$ $\mu\text{S}/\text{cm}$ should be corrected for salinity. Most modern sensors automatically compensate for the effects of salinity or have manual compensation techniques, but this should be verified by checking the manufacturer's instruction manual (Lewis, 2006).

DWQS uses two different sensors for measuring DO concentrations and saturations. The first is the luminescent sensor. The ROX DO (aka Optical DO) sensor has a light-emitting diode (LED) to illuminate a specially designed oxygen-sensitive substrate that, when excited, emits a luminescent light with a lifetime that is directly proportional to the ambient oxygen concentration. Although these sensors are more expensive, advantages include: faster response time, few known interferences, no dependence on flow, and increased stability. DWQS strongly recommends using the optical DO sensor for continuous instream monitoring over the next type of DO sensor.

Another DO sensor is the temperature-compensated polarographic membrane-type sensor. Although polarographic membrane-type sensors generally provide accurate results, they are sensitive to temperature and water velocity and are prone to fouling from algal growth and sedimentation. The measuring process consumes DO; therefore, water flow past the sensor is

critical. If the water velocity at the point of measurement is less than 1 foot per second (ft/s), an automatic or manual stirring mechanism is required. Chemical alteration of the DO electrodes can be caused by a strong oxidizing or reducing chemical agent, such as a chemical spill, by metal-rich drainage water, or by organic-rich waters.

Turbidity

Turbidity is defined as an expression of the optical properties of a sample that cause light to be scattered and absorbed rather than transmitted through a sample. Most turbidity sensors emit light from a LED into the water and measure the light that scatters or is absorbed by the suspended particles in the water. The sensor response is related to the wavelength of the incident light and the size, shape, and composition of the particulate matter in the water. The effect of temperature on turbidity sensors is minimal, and the software for modern sensors provides temperature compensation. Sensors that are regularly maintained and calibrated are somewhat error free. Turbidity sensors should be calibrated directly rather than by comparison with another meter (Anderson, 2005). Turbidity can be reported in several different units depending on what type of sensor is being used. The DWQS uses sensors that report data in formazin nephelometric units (FNU), because these sensors use near infra-red light (780-900nm) with a detection angle of 90°. For the purposes of measuring a calibration solution, turbidity units are equivalent. However, instruments may not produce equivalent results for environmental samples, which is why different turbidity units are required. Turbidity sensors typically have a range of 0–1,000 and an accuracy of ± 5 percent or 2 NTU, whichever is greater. Some sensors can report values reliably up to about 4,000 NTU.

Water Stage

Most stream monitors employ pressure transducers to measure water stage. The physical force measured is made up of various factors such as atmospheric pressure, temperature fluctuations, and water pressure. Pressure transducers convert physical force into an electronic signal to be calculated into water stage. Most modern stage sensors will automatically compensate for fluctuations in temperature.

Water stage sensors come in two common forms, non-vented and vented. Non-vented (absolute) sensors measure both atmospheric pressure and water stage simultaneously. Resulting data from non-vented sensors require corrections provided by either a separate barometric pressure monitor or by using barometric data from a near-by airport/weather station. Vented (gage) sensors employ a vent tube that is open to the air. As a result, these sensors will automatically compensate for the changes in atmospheric pressure as long as the vent tube remains unobstructed and dry.

Due to the monitor deployment method, DWQS generally uses non-vented pressure sensors to record water stage. A nearby barometric pressure monitor is typically used to correct for

atmospheric pressure changes. If separate barometric monitors are used, they should be set to the same sampling interval as the stream monitor to facilitate the data management process. Both stream monitor and barometric monitor must be calibrated at the respective monitoring site before logging begins.

When considering the use of a non-vented water stage sensor and a separate barometric monitor it is important to account for distance (between stream and barometric monitor) and elevation. DWQS generally recommends that distance between stream monitor and barometric monitor does not exceed 30 miles. This reduces the potential for barometric correction errors due to localized weather patterns. As a general rule for Pennsylvania, barometric pressure changes with elevation at a rate of 1 in-Hg for every 1000 ft. If the elevation difference from stream monitor to barometric monitor is minimal, then no elevation compensation is needed. Correcting for barometric pressure using another instrument adds to the total potential error within the data set. Unless the accuracy of each instrument can be documented and verified depth measurements are taken at each maintenance visit, the data must be dealt with in a qualitative manner.

Use of Field Meters

The three major uses for a field meter during servicing of a continuous water quality monitor are (1) as a general check of reasonableness of monitor readings, (2) as an independent check of environmental changes during the service interval, and (3) to make cross-section surveys or vertical profiles in order to verify the representativeness of the location of the sonde in the aquatic environment. The field meter typically should not be used directly to calibrate the instream monitor nor in the calibration correction of monitor records. However, some instream monitors cannot be calibrated, in which case the calibrated field meter must be used in the calibration correction of monitor records. In addition, the DWQS may use a calibrated field meter measurement in data correction for undocumented data error (a potential result from the DWQS deployment method). Independent field measurements must be made before, during, and after servicing the monitor to document environmental changes during the service. Measurements are made at the monitoring site by locating calibrated field instruments as close to the sensor as possible and at 10 second intervals, or more frequently if necessary.

Before site visits, all field meters should be checked for operation and accuracy. Minimum calibration frequency should be once per day in the field. Recalibration will be necessary when a sensor is replaced, and during dramatic changes in elevation or barometric pressure. Calibrations must be recorded in instrument log sheets. An example of a deployment form and a field meter log sheet used by DWQS is located in Appendix 1 and 2. The DWQS recommends that all sensors are calibrated in accordance with manufacture's specifications.

Monitor Operation and Maintenance

The goal for continuous instream monitoring is to obtain the most accurate and complete record possible. The common operational categories include maintenance frequency, field visits, troubleshooting, and comprehensive record keeping.

This instream monitoring protocol details one operating procedure designed for well-mixed, stable, and relatively slow changing systems. Slowly changing is defined as changes in field measurements during maintenance that are less than the calibration criteria (see Monitor Calibration Criteria). The wadeable streams of Pennsylvania generally fall into this category. Wagner and others (2006) describe a modified protocol for more stratified and dynamic aquatic environments such as lakes and estuaries.

Maintenance Frequency

DWQS monitors are typically placed at a station for about a year and revisited 10-12 times during the deployment. However, maintenance frequency will generally depend on fouling rate of the sensors, and this rate varies by sensor type, environmental conditions, and season. The performance of water temperature, specific conductance, and water stage sensors tends to be less affected by fouling than DO, pH, and turbidity sensors. Wiper mechanisms on turbidity and optical DO sensors have substantially decreased fouling in certain aquatic environments. Monitoring sites with nutrient-enriched waters and moderate to high temperatures may require more frequent maintenance. In cases of severe environmental fouling or in remote locations, the use of an observer to provide more frequent maintenance to the water quality monitor should be considered. Monitoring disruptions as a result of equipment malfunction, sedimentation, electrical disruption, debris, ice, or vandalism also may require additional site visits.

Field Visits

Field visits are undoubtedly the most important step in certifying that quality data are being recorded. The purposes of a field visit are to verify that a sensor is working accurately, upload recorded data, confirm calibrations, and provide a reference point for subsequent data management. Quality assurance is accomplished by recording field fouling observations (i.e. chemical precipitates, stains, siltation, or biological growths), before and after cleaning sensor readings in the environment, calibration checks, and final readings. It is important to conduct field checks at, or close to the monitor's deployment location in order to record checks that best represent stream conditions recorded by the monitor.

The standard protocol for servicing instream monitors is described below:

1. Obtain a discrete measurement from a clean, calibrated field meter at the sonde location
2. Remove sonde from the monitoring location being careful to minimize disturbance
3. Connect monitor to field instrument (i.e. computer or hand held device)
 - a. If monitor is to be submerged during read-out, ensure the cable is designed to operate under water
 - b. Stop unattended monitoring
 - c. Upload data
 - d. Record any significant fouling observed during monitor removal
4. Conduct monitor inspection
 - a. Record time, readings, and monitor conditions
 - b. With an independent field meter, record instream readings and time near the monitor
5. Clean sensors (see field cleaning of sensors)
6. Return sonde to the stream
 - a. Record monitor readings and time
 - b. Using an independent field meter, record instream readings near the monitor
7. Remove sonde, and check calibration (see field calibration of sensors)
 - a. Record calibration-check values
 - b. Recalibrate if necessary (see calibration criteria)
8. Conduct final readings
 - a. Record monitor readings and time
 - b. Using an independent field meter, observe and record readings near the monitor
9. Restart unattended sampling with appropriate logging interval, start time, and file name
 - a. DWQS recommends a delay start time of 1-2 hours to allow equipment to acclimate following disturbance of the site
 - b. Check monitor's battery levels, change if necessary
10. Return sonde to monitoring location and inspect anchoring equipment and shroud for deterioration and damage.

The initial sensor reading may not necessarily accurately represent ending point of the data record since the deployment or last servicing due to site disturbance that occurs while retrieving internal-logging and otherwise independently deployed monitors. Care should be taken to minimize disturbance and placement of the monitor and field meters should be upstream of any disturbed area. Significant fouling should be recorded in the field sheet. Monitors and field meters should be given ample time to stabilize before readings are recorded. During extreme conditions (extreme cold/heat, early morning, etc.) monitors and field meters may require more time to

stabilize. Initial sensor readings should be used in conjunction with the last data record recorded before disturbance to determine any affect disturbance may have had on initial sensor and field meter readings and to determine the validity of these readings. In general, the initial sensor reading and the field meter reading provides a sense of the reasonableness of the monitor readings and an indication of potential fouling errors.

After initial sensor readings, the monitoring sensors are inspected for signs of fouling. These observations are recorded in the field notes before cleaning, and then individual sensors are cleaned according to the manufacturer's specifications. The cleaned sonde or sensor is then returned to the water. Cleaned sensor readings, field meter readings, and times are recorded in the field notes. If the conditions are steady state, the field meter readings should not change substantially during the time that the monitoring sensors are cleaned. The observed difference between the initial sensor reading and the cleaned-sensor reading is a result of fouling (chemical precipitates, stains, siltation, or biological growths). After all cleaned-sensor readings are recorded, the monitor is removed from the water, calibration is checked in calibration standard solutions, and the readings are recorded (and recalibrated if necessary). Differences between the cleaned-sensor readings in calibration standard solutions and the expected reading in these solutions are the result of calibration error (drift). The sonde is recalibrated if necessary and replaced in the aquatic environment for a final reading.

The set of final readings may not necessarily accurately represent start of the new record period due to site disturbance. Extreme care should be taken to minimize disturbance and placement of the monitor and field meters should be upstream of any disturbed area. Monitors and field meters should be given ample time to stabilize before readings are recorded. Final sensor readings should be used in conjunction with the first data record recorded to determine any affect disturbance may have had on final sensor readings, field meter readings, and data collected as part of the new record period.

Field Cleaning of Sensors

During the cleaning process, care should be taken to ensure that the electrical connections are kept clean and dry. Water on the connector pins can cause erratic readings. For this reason, a container of compressed air is useful. Procedures for cleaning specific sensors (below) are general guidelines and should not replace manufacturer's instructions.

Most commercial thermistors can be cleaned with a soft-bristle brush and rinsed with deionized water (Wilde, 2006).

Clean specific conductance sensors thoroughly with de-ionized water before and after making a measurement. Oily residue or other chemical residues (salts) can be removed by using a detergent solution. Specific conductance sensors can soak in detergent solution for many hours without

damage. Carbon and stainless-steel sensors can be cleaned with a soft brush, but platinum-coated sensors should never be cleaned with a brush (Radtke et al., 2005).

The pH electrode must be kept clean in order to produce accurate pH values. The body of the electrode should be thoroughly rinsed with de-ionized water before and after use. In general, this is the only routine cleaning needed for pH electrodes; however, in cases of extreme fouling or contamination, the manufacturer's cleaning instructions must be followed (Ritz and Collins, 2008).

Optical DO sensors are cleaned with a soft bristle brush and rinsed with deionized water. If the optical DO sensor is equipped with a wiper, ensure the motor is operating properly and parking in the correct position. Also ensure that the wiping mechanism (pad or brush) is in good condition and clean.

Routine cleaning of polarographic DO sensors involves using a soft-bristle brush to remove silt from the outside of the sensor, wiping the membrane with a damp, lint-free cotton swab (available at local electronics stores), and rinsing with de-ionized water. The sensor usually is covered with a permeable membrane and filled with a potassium chloride solution. The membrane is fouled easily and typically will need to be replaced every 2 to 4 weeks. When the membrane is replaced, the potassium chloride solution must be rinsed out of the sensor with de-ionized water followed by several rinses with potassium chloride solution before the sensor is refilled. The membrane must be replaced with care so that the surface of the membrane is not damaged or contaminated with grease, and no bubbles are trapped beneath the membrane. The surface of the membrane should be smooth, and the membrane should be secured tightly with the retaining ring. The sensor must be stored in water for a minimum of 2 to 4 hours, preferably longer, to relax the membrane before installation and calibration. The time required to relax the membrane requires either replacing the DO sensor membrane with a pre-relaxed membrane and recalibrating or replacing the membrane and revisiting the site for calibration later. The retaining ring must be replaced annually or more frequently to prevent loss of electrolytes. Replacing the retaining ring when membranes are changed ensures a tight seal. The gold cathode of the DO sensor also can be fouled with silver over an extended period of time, and a special abrasive tool usually is required to recondition the sensor. A fouled anode, usually indicated by the white silver electrode turning gray or black, can prevent successful calibration. As with the cathode, the sensor anode usually can be reconditioned following the manufacturer's instructions. Following reconditioning, the sensor cup must be rinsed, refilled with fresh potassium chloride solution, and a new membrane installed (Lewis, 2006).

Turbidity sensors are extremely susceptible to fouling; thus, frequent maintenance trips may be necessary to prevent fouling of the turbidity sensor in a benthic environment high in fine sediment, algae accumulation, or other biological or chemical debris. In environments that cause severe algal fouling, however, algae can accumulate on the wiper pad preventing complete removal debris from the optical lens, resulting in erratic turbidity data. If the turbidity sensor is

not equipped with a mechanical cleaning device that removes solids accumulation or a shutter that prevents accumulation on the lens before readings are recorded, reliable data collection is very difficult. Sensors first should be inspected for damage, ensuring that the optical surfaces of the probe are in good condition. The wiper pad or other cleaning device also should be inspected for wear and cleaned or replaced if necessary. Before placing the turbidity sensor in standards, the optic lens should be carefully cleaned with alcohol by using a soft cloth to prevent scratching (or as recommended by the manufacturer), rinsed three times with turbidity-free water, and carefully dried. If the readings are unusually high or erratic during the sensor inspection, entrained air bubbles may be present on the optic lens and must be removed (Anderson, 2005).

Field Calibration of Sensors

An instream monitor should be calibrated in the field before installation. This avoids the potential errors of calibrating in a pressurized building as well as conserving standard solution. Calibration is done only by using calibration standards of known quality. During field visits, calibration of all sensors should be checked with at least two standard solutions (if possible) that bracket the range of expected environmental conditions and a third standard near the ambient environmental conditions before any adjustments are made to the monitor calibration. Field calibration is performed if the cleaned-sensor readings obtained during the calibration check differ by more than the calibration criteria (table 1). Spare monitoring sondes or sensors are used to replace water quality monitors that fail calibration after troubleshooting steps have been applied (see Troubleshooting Procedures). All calibration equipment and supplies must be kept clean, stored in protective cases during transportation, and protected from extreme temperatures.

Use the following example to better understand the calibration criteria given in table 1. The calibration criterion for specific conductance is $5\mu\text{S}/\text{cm}$ or 3%, whichever is greater. Therefore, if you have a sonde in $1000\mu\text{S}/\text{cm}$ standard and got a reading of $1025\mu\text{S}/\text{cm}$ the reading would still be within the calibration criteria because 3% of $1000\mu\text{S}/\text{cm}$ ($30\mu\text{S}/\text{cm}$) is greater than $5\mu\text{S}/\text{cm}$. For a calibration check in $100\mu\text{S}/\text{cm}$ standard the criteria would be $5\mu\text{S}/\text{cm}$, because $5\mu\text{S}/\text{cm}$ is greater than 3% of $100\mu\text{S}/\text{cm}$. Sensors with readings outside of criteria will be recalibrated during the field visits. Best professional judgment should be used with values that read close to calibration criteria. Data management is often facilitated by eliminating unnecessary calibration events.

Table 1. Calibration criteria for measured parameters.

Field Parameter	Calibration Criteria
Temperature	$\pm 0.2^{\circ}\text{C}$
Specific Conductance	$\pm 5 \mu\text{S}/\text{cm}$ or 3%, whichever is greater
pH	± 0.2 units
Dissolved Oxygen	$\pm 0.3 \text{ mg}/\text{L}$
Turbidity	$\pm 0.5 \text{ NTU}$ or $\pm 5\%$, whichever is greater

Using Standard Solutions

Expiration dates and lot numbers for the standard solutions must be recorded and the standard solution bottles allowed to equilibrate to ambient water temperature (by immersing in the water for 15 to 30 minutes). After the calibration standard solutions are checked and recorded (without making any adjustments), the monitor is recalibrated, if necessary, by using the appropriate calibration standard solutions and following the manufacturer’s calibration procedures. The sensor, thermistor or thermometer, and measuring container must be rinsed three times with a standard solution. Gentle tapping will ensure that no air bubbles are trapped on the sensor. Fresh standard solution is poured into the calibration cup ensuring both the thermistor and the sensor are submerged; the sensor values, calibration standard values, and temperature are recorded in the field log sheet. A temperature correction may be necessary if the monitor does not have automatic temperature correction. Standard solution that has been used is discarded, and the procedure is repeated using a second or third standard solution to check consistency of sensor response. If the sensor readings differ from the standards by more than the defined criteria, the calibration sequence is repeated. If the second calibration sequence still differs by more than the calibration criteria, troubleshooting techniques will be attempted (see Troubleshooting Procedures). If these steps fail, the sonde or monitoring sensor must be replaced and the backup instrument calibrated (Wagner et al., 2006).

Water Temperature Sensors

Manufacturers generally make no provisions for field calibration of water temperature sensors. The water temperature sensor and the calibrated field thermistor are placed adjacent to each other, preferably in flowing water. Sufficient time for temperature equilibration must elapse before a reading is made. The two water temperature sensors must be read and the temperatures recorded instantaneously. If the monitoring water temperature sensor fails to agree within $\pm 0.2^{\circ}\text{C}$, troubleshooting steps must be taken; if troubleshooting fails, the sensor must be replaced. The faulty sensor or sonde should be returned to the manufacturer for proper calibration, repair, or replacement (Wilde, 2006).

Specific Conductance Sensors

Calibration of specific conductance sensors should be checked with at least two calibration standard solutions of known quality before any adjustments are made. In addition, the zero response of the dry sensor in air should be checked and recorded to ensure linearity of sensor response at low values. If the sensor-cleaning process fails to bring a specific conductance sensor within the calibration criteria (table 1), the sensor must be recalibrated. The manufacturer's calibration procedures should be followed (Radtke et al., 2005).

pH Sensors

The DWQS uses a three point (4, 7, 10) calibration for pH for both the field meter and the instream monitor. Expiration dates for the buffer solutions are checked and recorded. Spare pH sensors or entire backup monitors are carried in case replacement of the sensors is required.

Dissolved Oxygen Sensors

Dissolved oxygen in water is related to water temperature, atmospheric pressure, and salinity. Calibration of DO sensors should be checked at 100% saturation and with a fresh zero-DO solution before any adjustments are made. The manufacturer's calibration procedures must be followed closely to achieve a calibrated accuracy of ± 0.3 mg/L concentration of DO (Lewis, 2006). Theoretical charts based off of water temperature and barometric pressure should be used to confirm calibration of monitors. A general 100% saturation chart for fresh water is provided in Appendix 3. Customized charts can also be made from the following USGS website: <http://water.usgs.gov/software/DOTABLES/>.

Most DO sensors can be calibrated only with a one-point calibration, usually at 100-percent saturation, although some sondes have the capability of a two-point calibration, at zero-percent and 100-percent saturation. For the sondes that are calibrated only at 100-percent saturation, the DO sensor response is checked in a zero-DO sodium sulfite/cobalt chloride solution. A fresh zero-DO standard solution should be prepared before each monitor visit. Letting the sensor go completely to zero may cause damage. DWQS recommends letting the sensor go down to 0.3 mg/L, and then take the sensor out of the zero DO solution.

Preparation of the zero DO solution is described below:

Dissolve 0.5 gram of sodium sulfite and 6 – 10 crystals of cobalt chloride in 500 ml of deionized water.

Luminescent-based DO sensors are calibrated by the manufacturer, and the manuals indicate that calibration may not be required for up to a year. When calibrated, the user should follow the manufacturer's guidance. Regardless of the manufacturer's claims, the user must verify the correct

operation of the sensor in the local measurement environment. The standard protocol for servicing should be used for luminescent-based DO sensors to quantify the effects of fouling and calibration drift (Lewis, 2006). Recalibration should not be necessary if calibration checks show the sensor to be in agreement with the calibration criteria (table 1) and theoretical chart values (see Appendix 4).

Calibration of polarographic sensors in the field presents a problem because replacement of the Teflon® membrane may be required frequently, and the replaced membrane must be allowed to “relax” in water for 2–4 hours before calibration. One solution to this problem is to carry into the field clean and serviced spare DO sensors, stored in water (or moist, saturated air). The replacement DO sensors then can be calibrated in the field, thus avoiding an interruption in the record and a return site visit (Lewis, 2006).

Turbidity Sensors

Optimal calibrations and checks are made with three standard solutions that cover the expected range of values, although many sensors only allow for a two point calibration. Calibration of the turbidity sensor is made by using standard turbidity solutions and by following the manufacturer’s calibration instructions. DWQS does not recommend diluting any standard solutions using dilution formulas due to potentially introducing error. Deionized or Ultrapure (filtered and deionized) water may be used as a zero turbidity standard if its turbidity is measured by a laboratory. Laboratory measurements are necessary because Deionized or Ultrapure turbidity typically ranges between 0.2 NTU and 1.0 NTU. The measured turbidity from the laboratory can be set as an offset calibration in the monitor, or the data can be offset corrected later in data management. Checking or calibrating the turbidity sensor should occur in a stable environment with minimal movement, wind, or exposure to sunlight. Sufficient space between the sensor and the bottom of the calibration cup is also critical during checks and calibration. Follow the manufacturer’s recommendations for calibration.

Water Stage Sensors

Water stage calibration procedures vary slightly with manufacturer, so DWQS recommends following manufacture’s recommendations. When calibrating water stage for deployment it is important to calibrate at the monitoring location. Most non-vented sensors will calibrate to a depth of zero in the air. This accounts for the elevation and atmospheric pressure at the monitoring site. Since there is no change in elevation during deployment and most pressure transducers automatically compensate for water temperature, the only corrections needed are changes in barometric pressure.

In locations where an immobile reference cannot be found, a staff plate or form/rebar stake may be employed. A staff plate or stake that’s driven into the stream bed provides a point of reference

for consistent manual stage measurements which can be compared to monitor recordings at the time of a field visit. Staff plate or stake measurements may serve as verified discrete data for subsequent data management purposes.

Troubleshooting Procedures

If a sensor cannot be calibrated with standard solutions, determine if the problem is with the sensor or the entire monitor and make the corrections to ensure correct operational. Spare sensors and monitors should be carried so that corrections can be made during the service visit. Troubleshooting in the field prevents extra trips, saves time, and greatly reduces record loss. A service trip should result in a calibrated and fully functional monitor. Some common problems and potential solutions are listed in table 2.

Table 2. Troubleshooting procedures for the most common issues encountered in the field.

Symptom	Possible Issue	Likely Solution
Water Temperature		
Thermistor is not reading accurately	Dirty sensor	Clean sensor
Erratic readings	Poor or wet connection at monitor or sensor	Dry and tighten connection
Slow to stabilize	Dirty sensor	Clean sensor
Reading off scale	Failure in electronics	Replace sensor or monitor
Specific Conductance		
Will not calibrate	Standard solution old or contaminated Electrodes Dirty Air trapped around sensor Weak batteries	Use fresh standard solution Clean with brush Tap gently to expel air Replace batteries
Erratic readings	Poor or wet connection at monitor or sensor	Dry and tighten connection
Requires frequent calibration	Broken cables	Replace cables Replace monitor
pH		
Will not calibrate	Standard solution old or contaminated Faulty Sensor	Replace buffer Replace sensor
Erratic readings	Loose or defective connections Defective sensor	Tighten connections Replace sensor
Slow response time	Dirty sensor bulb Water is cold or of low ionic strength	Clean sensor Be patient
Dissolved Oxygen		
Will not calibrate	Membrane Damaged Electrolyte diluted	Replace membrane Replace membrane and electrolyte
Erratic readings	Bad connection at monitor or sensor Fouled sensor	Tighten connections Check for obstructions or replace
Slow to stabilize	Gold cathode tarnished Fouled membrane Silver anode corroded	Buff with eraser or recondition sensor Replace membrane and recondition Replace sensor and soak fouled sensor in 3% ammonia for 24 hours
Will not zero	Zero DO solution contains oxygen Zero DO solution is old	Add additional sodium sulfite Mix fresh solution
Turbidity		
Unusually high or erratic readings	Entrained air bubbles on the sensor Damaged Sensor Dirty sensor Water in connection	Follow manufacturer's directions Replace sensor Clean, using soft brush Dry connection and reinstall

Field Notes and Instrument Logs

The DWQS uses an electronic deployment and field form (Appendix 2 and 3, respectively) similar to the USGS standard field form for water quality monitors in Wagner et al., 2006. Logs and field

notes are essential for accurate and efficient record processing. Field-note requirements for instream monitors are included below:

1. Station name
2. Date and time of measurements
3. Name(s) of data collector(s)
4. Serial number of field meters and monitor
5. Lot numbers and expiration dates of standard solutions
6. Location description and picture of monitor in the stream
7. Monitor values, field meter values, and corresponding time for pre-cleaned, cleaned, calibration checks, calibrations/recalibrations, and final readings
8. Cross-section survey data (locations of points, measured values, and corresponding times), and monitor values before and after the cross-section survey
9. Measured flow or gage-height data
10. Comments on site conditions, sensor condition, and any other pertinent observations
11. Battery voltage of monitor at departure and if the batteries were replaced
12. Notes on sensor/monitor changes or replacements, and other comments that facilitate processing of the record

The goal is to have enough information so that anyone can independently process the collected data with analogous results.

References

- Anderson, C.W., 2005, Turbidity (ver. 2.1): U.S. Geological Survey Techniques of Water-Resources Investigations, book 9, chap. A6., sec. 6.7, September, 2005, accessed September 6, 2011, from <http://pubs.water.usgs.gov/twri9A6/>.
- Lewis, M.E., 2006, Dissolved Oxygen (ver. 2.1): U.S. Geological Survey Techniques of Water-Resources Investigations, book 9, chap. A6., sec. 6.2, June 2006, accessed September 6, 2011, from <http://pubs.water.usgs.gov/twri9A6/>.
- Radtke, D.B., J.V. Davis, and F.D. Wilde, 2005, Specific Electrical Conductance (ver. 1.2): U.S. Geological Survey Techniques of Water-Resources Investigations, book 9, chap. A6., sec. 6.3, August 2005, accessed September 6, 2011, from <http://pubs.water.usgs.gov/twri9A6/>.
- Ritz G.F., and J.A. Collins, 2008. pH (ver. 2.0): U.S. Geological Survey Techniques of Water-Resources Investigations, book 9, chap. A6., sec. 6.4, November 2008, accessed September 6, 2011, from <http://pubs.water.usgs.gov/twri9A6/>.
- Wagner, R.J., Boulger, R.W., Jr., Oblinger, C.J., and Smith, B.A., 2006, Guidelines and standard procedures for continuous water-quality monitors—Station operation, record computation, and data reporting: U.S. Geological Survey Techniques and Methods 1–D3, 51 p. + 8 attachments; accessed August 30, 2011, at <http://pubs.water.usgs.gov/tm1d3>
- Wilde, F.D. 2006, Temperature (ver. 2.0): U.S. Geological Survey Techniques of Water-Resources Investigations, book 9, chap. A6., sec. 6.1, March 2006, accessed September 6, 2011, from <http://pubs.water.usgs.gov/twri9A6/>.

Appendix 1. Deployment Form

STATION NAME											
METER MAKE/MODEL											
METER SERIAL NO.											
DATE											
TIME											
FILE NAME											
LOGGING START TIME											
BATTERY LIFE (DAYS)											
MEMORY (DAYS)											
pH											
Temp	Standard	Chart Value	Reads	Adjusted	Slope	Buffer Mfg	Buffer Lot No	Buffer Exp	Calibration Location	Millivolts	Initials
SPECIFIC CONDUCTANCE											
Low Level Check (100)	Temp	Standard	Reads	Adjusted	SRF	Stand Mfg	Stand Lot No	Stand Exp	Calibration Location	Cond Gain	Initials
	Standard Calibration										
	Reading in Air (should be 0) =										
DISSOLVED OXYGEN											
Temp	Baro Pressure	Thero Value	Reads (%)	Reads (mg/L)	Final (%)	Final (mg/L)	DO Gain	DO charge	Calibration Location	Zero DO Value	Initials
TURBIDITY											
Temp	Standard	Reads	Adjusted	Probe	Stand Mfg	Stand Lot No	Stand Exp	Calibration Location	Gain	Constant	Initials
DEPTH											
Baro. Pressure(mmHg):				Start Depth				Recalibrated Depth			
LOCATION DESCRIPTION											

Appendix 2. Field Form

Station Name												
Inspected By												
Date												
Time												
Monitor Make/Model												
Monitor Serial No.												
Field Meter Make/Model												
Field Meter Serial No.												
Comments/File Name:												
MONITOR FOULING CHECKS												
Parameter	Before Cleaning		After Cleaning									
	Time:		Time:									
	Recorded/Live Value	Field Meter	Recorded/Live Value	Field Meter								
Temp (°C)												
pH (Units)												
DO (mg/L)												
SC (µS/cm)												
Turbidity (NTU)												
Other:												
CALIBRATION DRIFT CHECKS												
DEPTH		Calibration Check/Recalibration										
		Time:										
Baro. Pressure(mmHg):		Start Depth		Recalibrated Depth								
Comments:												
SPECIFIC CONDUCTANCE Calibration Criteria: the greater of 5 µS/cm or 3% of measured value												
Time: <input type="text"/>												
Time: <input type="text"/>												
Std Value	Std Lot No	Std Type	Thero	Exp Date	Temp	Reading	Error %	Temp	Reading	SRF	Error %	
Cell Range=		Reading in air = (Should be 0)										
Comments:												
DISSOLVED OXYGEN Calibration Criteria: ± 0.3 mg/L												
Time: <input type="text"/>												
Time: <input type="text"/>												
Salinity Corr. Factor	Baro Press	Thero Value	Temp	DO Reading	Error %	Reading in zero DO Sol'n	Baro Press	Thero Value	Temp	DO Reading	Error %	Reading in zero DO Sol'n

SALINITY:		SALINITY CORRECTION APPLIED?		DO CHARGE:		DO GAIN:		Date Barometer Calibrated:			
Comments:											
pH				Calibration Check			Recalibration				
Calibration Correction: ± 0.2 pH units				Time:			Time:				
pH Buffer	Theoretical pH from Table	Buffer Lot No.	Exp Date	Temp	Reading	Error %	Temp	Reading	Error %	Slope	Milli volts
pH 7											
pH 4											
pH 10											
Comments:											
TURBIDITY				Calibration Check			Recalibration				
Calibration Criteria: ± 0.5 Turbidity units or $\pm 5\%$				Time:			Time:				
	Lot No. or Date Prepared	Conc	Temp	Reading	Error %	Temp	Reading	Error %			
Stock Standard											
Zero Standard (DIW)											
Standard 1											
Standard 2											
Standard 3											
Turbidity Sensor limit:		Comments:									
FINAL READINGS							Time:				
Parameter				Recorded / Live Value			Field Meter				
Temp (°C)											
pH (Units)											
DO (mg/L)											
SC (µS/cm)											
Turbidity (NTU)											
Other:											
FILE NAME											
LOGGING START TIME											
BATTERY LIFE (DAYS)											
MEMORY (DAYS)											
SONDE LOGGING OR PULLED?											

Appendix 3. Dissolved Oxygen (mg/L) 100% Saturation Chart for Fresh Water.

Tem p °C	Barometric Pressure (mm Hg)														
	700	705	710	715	720	725	730	735	740	745	750	755	760	765	770
0.0	13.46	13.56	13.65	13.75	13.85	13.94	14.04	14.14	14.23	14.33	14.43	14.52	14.62	14.72	14.81
0.5	13.27	13.37	13.46	13.56	13.65	13.75	13.84	13.94	14.03	14.13	14.22	14.32	14.41	14.51	14.60
1.0	13.09	13.18	13.27	13.36	13.45	13.54	13.63	13.72	13.81	13.90	14.00	14.09	14.18	14.27	14.36
1.5	12.91	13.00	13.09	13.18	13.27	13.36	13.45	13.54	13.63	13.72	13.81	13.90	14.00	14.09	14.18
2.0	12.73	12.82	12.91	13.00	13.09	13.18	13.27	13.36	13.45	13.54	13.63	13.72	13.81	13.90	14.00
2.5	12.56	12.65	12.74	12.83	12.92	13.01	13.10	13.19	13.28	13.37	13.46	13.55	13.64	13.73	13.82
3.0	12.39	12.48	12.57	12.66	12.75	12.84	12.93	13.02	13.11	13.20	13.29	13.38	13.47	13.56	13.65
3.5	12.23	12.32	12.41	12.50	12.59	12.68	12.77	12.86	12.95	13.04	13.13	13.22	13.31	13.40	13.49
4.0	12.07	12.16	12.25	12.34	12.43	12.52	12.61	12.70	12.79	12.88	12.97	13.06	13.15	13.24	13.33
4.5	11.91	11.99	12.08	12.17	12.26	12.35	12.44	12.53	12.62	12.71	12.80	12.89	12.98	13.07	13.16
5.0	11.75	11.83	11.92	12.01	12.10	12.19	12.28	12.37	12.46	12.55	12.64	12.73	12.82	12.91	13.00
5.5	11.60	11.68	11.77	11.86	11.95	12.04	12.13	12.22	12.31	12.40	12.49	12.58	12.67	12.76	12.85
6.0	11.45	11.53	11.62	11.71	11.80	11.89	11.98	12.07	12.16	12.25	12.34	12.43	12.52	12.61	12.70
6.5	11.30	11.38	11.47	11.56	11.65	11.74	11.83	11.92	12.01	12.10	12.19	12.28	12.37	12.46	12.55
7.0	11.15	11.23	11.32	11.41	11.50	11.59	11.68	11.77	11.86	11.95	12.04	12.13	12.22	12.31	12.40
7.5	11.00	11.08	11.17	11.26	11.35	11.44	11.53	11.62	11.71	11.80	11.89	11.98	12.07	12.16	12.25
8.0	10.85	10.93	11.02	11.11	11.20	11.29	11.38	11.47	11.56	11.65	11.74	11.83	11.92	12.01	12.10
8.5	10.70	10.78	10.87	10.96	11.05	11.14	11.23	11.32	11.41	11.50	11.59	11.68	11.77	11.86	11.95
9.0	10.55	10.63	10.72	10.81	10.90	10.99	11.08	11.17	11.26	11.35	11.44	11.53	11.62	11.71	11.80
9.5	10.40	10.48	10.57	10.66	10.75	10.84	10.93	11.02	11.11	11.20	11.29	11.38	11.47	11.56	11.65
10.0	10.25	10.33	10.42	10.51	10.60	10.69	10.78	10.87	10.96	11.05	11.14	11.23	11.32	11.41	11.50
10.5	10.10	10.18	10.27	10.36	10.45	10.54	10.63	10.72	10.81	10.90	10.99	11.08	11.17	11.26	11.35

Temp p °C	Barometric Pressure (mm Hg)														
	700	705	710	715	720	725	730	735	740	745	750	755	760	765	770
11.0	10.15	10.22	10.29	10.37	10.44	10.51	10.59	10.66	10.73	10.81	10.88	10.95	11.03	11.10	11.17
11.5	10.03	10.10	10.17	10.24	10.31	10.38	10.45	10.52	10.59	10.66	10.73	10.80	10.87	10.94	11.01
12.0	9.91	9.99	10.06	10.13	10.20	10.27	10.34	10.41	10.48	10.55	10.62	10.69	10.76	10.83	10.90
12.5	9.80	9.87	9.94	10.02	10.09	10.16	10.23	10.30	10.37	10.44	10.51	10.58	10.65	10.72	10.79
13.0	9.69	9.76	9.83	9.90	9.97	10.04	10.11	10.18	10.25	10.32	10.39	10.46	10.53	10.60	10.67
13.5	9.59	9.65	9.72	9.79	9.86	9.93	10.00	10.07	10.14	10.21	10.28	10.35	10.42	10.49	10.56
14.0	9.48	9.55	9.62	9.69	9.76	9.82	9.89	9.96	10.03	10.10	10.17	10.24	10.31	10.38	10.45
14.5	9.38	9.44	9.51	9.58	9.65	9.72	9.78	9.85	9.92	9.99	10.06	10.13	10.20	10.27	10.34
15.0	9.27	9.34	9.41	9.48	9.54	9.61	9.68	9.75	9.81	9.88	9.95	10.02	10.09	10.16	10.23
15.5	9.18	9.24	9.31	9.38	9.44	9.51	9.58	9.64	9.71	9.78	9.84	9.91	9.98	10.04	10.11
16.0	9.08	9.14	9.21	9.28	9.34	9.41	9.47	9.54	9.61	9.67	9.74	9.80	9.87	9.94	10.00
16.5	8.98	9.05	9.11	9.18	9.24	9.31	9.37	9.44	9.50	9.57	9.64	9.70	9.77	9.83	9.90
17.0	8.89	8.95	9.02	9.08	9.15	9.21	9.28	9.34	9.41	9.47	9.54	9.60	9.66	9.73	9.79
17.5	8.80	8.86	8.92	8.99	9.05	9.12	9.18	9.24	9.31	9.37	9.44	9.50	9.57	9.63	9.69
18.0	8.70	8.77	8.83	8.90	8.96	9.02	9.09	9.15	9.21	9.28	9.34	9.40	9.47	9.53	9.59
18.5	8.62	8.68	8.74	8.80	8.87	8.93	8.99	9.06	9.12	9.18	9.24	9.31	9.37	9.43	9.50
19.0	8.53	8.59	8.65	8.72	8.78	8.84	8.90	8.96	9.03	9.09	9.15	9.21	9.28	9.34	9.40
19.5	8.44	8.50	8.57	8.63	8.69	8.75	8.81	8.87	8.94	9.00	9.06	9.12	9.18	9.25	9.31
20.0	8.36	8.42	8.48	8.54	8.60	8.66	8.73	8.79	8.85	8.91	8.97	9.03	9.09	9.15	9.21
20.5	8.28	8.34	8.40	8.46	8.52	8.58	8.64	8.70	8.76	8.82	8.88	8.94	9.00	9.06	9.12
21.0	8.19	8.25	8.31	8.37	8.43	8.49	8.55	8.61	8.67	8.73	8.79	8.85	8.92	8.98	9.04
21.5	8.11	8.17	8.23	8.29	8.35	8.41	8.47	8.53	8.59	8.65	8.71	8.77	8.83	8.89	8.95

Temp °C	Barometric Pressure (mm Hg)														
	700	705	710	715	720	725	730	735	740	745	750	755	760	765	770
22.0	8.04	8.09	8.15	8.21	8.27	8.33	8.39	8.45	8.51	8.57	8.63	8.68	8.74	8.80	8.86
22.5	7.96	8.02	8.08	8.13	8.19	8.25	8.31	8.37	8.43	8.48	8.54	8.60	8.66	8.72	8.78
23.0	7.88	7.94	8.00	8.06	8.11	8.17	8.23	8.29	8.35	8.40	8.46	8.52	8.58	8.64	8.69
23.5	7.81	7.86	7.92	7.98	8.04	8.09	8.15	8.21	8.27	8.33	8.38	8.44	8.50	8.56	8.61
24.0	7.73	7.79	7.85	7.90	7.96	8.02	8.08	8.13	8.19	8.25	8.30	8.36	8.42	8.48	8.53
24.5	7.66	7.72	7.77	7.83	7.89	7.94	8.00	8.06	8.11	8.17	8.23	8.28	8.34	8.40	8.45
25.0	7.59	7.65	7.70	7.76	7.81	7.87	7.93	7.98	8.04	8.10	8.15	8.21	8.26	8.32	8.38

25.5	7.52	7.58	7.63	7.69	7.74	7.80	7.85	7.91	7.97	8.02	8.08	8.13	8.19	8.24	8.30
26.0	7.45	7.51	7.56	7.62	7.67	7.73	7.78	7.84	7.89	7.95	8.00	8.06	8.11	8.17	8.22
26.5	7.38	7.44	7.49	7.55	7.60	7.66	7.71	7.77	7.82	7.88	7.93	7.99	8.04	8.10	8.15
27.0	7.32	7.37	7.43	7.48	7.53	7.59	7.64	7.70	7.75	7.81	7.86	7.91	7.97	8.02	8.08
27.5	7.25	7.30	7.36	7.41	7.47	7.52	7.57	7.63	7.68	7.74	7.79	7.84	7.90	7.95	8.01
28.0	7.19	7.24	7.29	7.35	7.40	7.45	7.51	7.56	7.61	7.67	7.72	7.77	7.83	7.88	7.93
28.5	7.12	7.18	7.23	7.28	7.33	7.39	7.44	7.49	7.55	7.60	7.65	7.71	7.76	7.81	7.87
29.0	7.06	7.11	7.16	7.22	7.27	7.32	7.38	7.43	7.48	7.53	7.59	7.64	7.69	7.74	7.80
29.5	7.00	7.05	7.10	7.15	7.21	7.26	7.31	7.36	7.42	7.47	7.52	7.57	7.62	7.68	7.73
30.0	6.94	6.99	7.04	7.09	7.14	7.20	7.25	7.30	7.35	7.40	7.46	7.51	7.56	7.61	7.66

Appendix B

Pennsylvania DEP:

Discrete Water Quality Monitoring Field

Form

DISCRETE TRANSECT FIELD FORM											
WATERBODY NAME (Juniata River)											
TRANSECT NAME (Newport Transect)											
METER MAKE/MODEL (YSI/ProPlus or YSI/6920)											
METER SERIAL NO.											
DATE											
COLLECTOR(S)											
TIME OF CAL. OR INITIAL CHECK											
TIME OF FINAL CHECK											
CALIBRATION OR INITIAL pH CHECK											
Temp (°C)	Standard	Chart Value	Reads	Adjusted	Slope	Buffer Mfg.	Buffer Lot No.	Buffer Exp.	Calibration Location	Millivolts	Initials
	7.00										
	4.00										
	10.00										
AFTER pH CHECK											
Temp (°C)	Standard	Chart Value	Reads	Adjusted	Slope	Buffer Mfg.	Buffer Lot No.	Buffer Exp.	Calibration Location	Millivolts	Initials
	7.00										
	4.00										
	10.00										
CALIBRATION OR INITIAL SPECIFIC CONDUCTANCE CHECK											
	Temp (°C)	Standard	Reads	Adjusted	SPE	Std Mfg.	Std. Lot No.	Std. Exp.	Calibration Location	Cond. Gain	Initials
Low Level Check (100)		100									
Standard Calibration		1000									
Reading in Air (should be 0)											
AFTER SPECIFIC CONDUCTANCE CHECK											
	Temp (°C)	Standard	Reads	Adjusted	SPE	Std Mfg.	Std. Lot No.	Std. Exp.	Calibration Location	Cond. Gain	Initials
Low Level Check (100)		100									
Standard Calibration		1000									
Reading in Air (should be 0)											
CALIBRATION OR INTIAL DISSOLVED OXYGEN CALIBRATION											
Temp (°C)	Baro. Pressure	Thero. Value	Reads (%)	Reads (mg/L)	Final (%)	Final (mg/L)	DO Gain	DO charge	Calibration Location	Zero DO Value	Initials
AFTER DISSOLVED OXYGEN CHECK											
Temp (°C)	Baro. Pressure	Thero. Value	Reads (%)	Reads (mg/L)	Final (%)	Final (mg/L)	DO Gain	DO charge	Calibration Location	Zero DO Value	Initials

Appendix C

Pennsylvania DEP Field Protocol:

Periphyton Standing Crop and Species

Assemblages

Introduction

Benthic algal communities are significant primary producers in wadable streams and can be utilized as indicators of environmental conditions (Barbour et al. 1999). Periphyton standing crop and community composition are influenced by nutrient levels, light, hydrologic condition, temperature, substrate type, and herbivore grazing (Stevenson, 1996). Accrual of benthic algal standing crop depends primarily on the level of two resources : nutrients and light (Biggs, 1996). Generally, filamentous chlorophytes become abundant sometimes creating nuisance conditions when high nutrient levels and adequate sunlight are provided. Studies have shown that phosphorous concentrations of only 25 to 50 ug/l orthophosphate are needed to maintain maximum benthic algal biomass in streams (Borchardt, 1996). Nuisance levels of algae and periphyton community shifts associated with high nutrients may cause water quality impairment (e.g. low dissolved oxygen), negative impacts to macroinvertebrates and fish, and/or aesthetic impairments for water uses (Dodds and Welch, 2000).

The purpose of this methods document is to provide a statewide standard field protocol for assessing potential nutrient impairment as part of the Department's Instream Comprehensive Evaluations and provide nutrient and biological response data to support Pennsylvania's nutrient criteria development. Field methods described include : 1) epilithic periphyton sampling for standing crop, community assemblage, and cellular nutrient concentration, 2) periphyton field description, and 3) physicochemical site conditions at the time of sampling.

Epilithic Periphyton Sampling

Epilithic periphyton sampling is conducted using a **Pennsylvania Epilithic Periphyton Sampler (PEP Sampler)**. The PEP sampler provides a fixed circular sample area (17.8 cm², 2" to 1.5" PVC Step Down Fitting) with a foam gasket seal (toilet seal) that is clamped to rock substrates (large gravel, cobble, small boulder) using Trex^R clamping boards that can be tightened with quick release 5-star knobs (Rockler.com) or wing nuts on threaded rods (Figure 1).

Select a riffle that is visually representative with regard to substrate size, shading, and periphyton standing crop of riffle habitat at the station you are sampling. Riffles are the priority richest targeted habitat for quantitative sampling described in USGS's Revised Protocols for Sampling Algal, Invertebrate, and Fish Communities as Part of the National Water-Quality Assessment Program (Moulton et.al. 2002). If riffles are absent, a run should be sampled. Visually stratify the riffle/run into thirds (upper, middle, lower), and randomly place one flag marker along the bank of the stream in each segment. Markers denote the location of three sampling transects perpendicular to the stream and should be placed without looking closely at the streambed or periphyton condition to help ensure unbiased sampling. The collector should not walk through the areas to be sampled prior to rock collection and should work downstream to upstream to ensure the periphyton community is undisturbed prior to sampling.

Three rocks are randomly collected for each transect. Three random numbers (0.00 to 0.99) are generated for each transect using two different colored 10-sided die (ea. die #1 = 5, die #2 = 8, percentage = 0.58). Wetted width for each transect is measured (left bank to right bank looking downstream). The wetted width is divided by 3 to stratify substrate collection locations into left, center, and right 1/3 of the channel along the transect. One third of the channel width is multiplied by the first random number to determine collection location 1; 1/3 channel width is multiplied by the second random number and 1/3 channel width is added to determine collection location 2; 1/3 channel width is multiplied by the third random number and 2/3 channel width is added to determine collection location

3. The three rocks along each transect are composited (Figure 2). When retrieving rocks the collector should reach down at the collection location and pick a rock by touching it lightly with a finger while refraining to look at the streambed. If the rock is a suitable size for periphyton sampling (will accept a 2 inch diameter seal) it is placed in an empty dishpan (for transport to the PEP sampler. If the substrate is too small to obtain an adequate PEP sampler seal or too large to remove (large boulder, bedrock), the collector should retrieve the closest rock to the selected rock that is of suitable size for sampling. Dishpans can be covered to protect samples from sunlight and desiccation prior to scraping.

Clamp rocks to the PEP sampler. Prior to sampling, check to ensure that water is ponding around the gasket indicating a tight seal. Attached algae is removed by repeated scrubbing with a modified grout brush, rinsing with distilled or deionized water and transferring the slurry to a plastic sample container (approx. 1 liter) with a modified wide bore disposable pipette or turkey baster. Removal of filamentous green algae (ea. *Cladophora*) may require cutting/scraping with an Exacto knife. Scrub the area for a minimum of 60 seconds until the area is visibly devoid of algae. Rinse water will appear clear after sampling unless substrates are easily erodable (ea. shale, sandstone). Slurry from the three transects (3 rocks each) are initially composited in separate sample containers. Total sample volumes are determined by pouring the algal slurries into a 500 ml volumetric cylinder. A funnel should be used for transfers to minimize spillage. Slurries can be processed in the field or returned to a regional laboratory for processing.

Samples containing filamentous macroalgae require blending utilizing a blender or food processor to homogenize the sample by breaking apart filaments. Well-mixed subsamples (shaking a wide-mouth bottle, or blending) from each transect composite are taken for 1) Chlorophyll-a and Phaeophytin analysis, 2) cellular carbon and nitrogen, and 3) cellular phosphorous. Subsamples for filtration are taken using a Hensen-Stempel pipette (2ml) or a conventional “to deliver” pipette with a modified wide bore tip. Chl-a samples are filtered onto glass fiber filters (Whatman EPM 2000, 0.3 um, 47mm) using a filter apparatus and vacuum pump (≤ 10 psi). Chl-a filter volumes are dependent upon algal slurry concentrations but should be in the range from 2ml (eutrophic, unshaded) to 10 ml (oligotrophic, shaded). After releasing the vacuum, dry filters are removed from the filter apparatus using flat-ended filter forceps. Filters are quartered and wrapped in aluminum foil. Cellular carbon and nitrogen samples are filtered onto glass fiber filters (Whatman EPM 2000, 0.3 um, 47mm). NC Filter volumes are dependent upon algal slurry concentration but should range from 10ml to 30ml. Cellular P samples are filtered onto polycarbonate filters (Millipore Polycarbonate, 0.2um, 47mm). P Filter volumes are dependent upon algal slurry concentration but should range from 10 ml to 30ml. Cellular P filtration is a time limiting step because of the slow filtration rate. If available, two filter apparatuses will help shorten processing time. As with the Chl-a filters, NC and P filters are quartered and wrapped in aluminum foil. Care should be taken to only handle the cellular nutrient filters with forceps to avoid potential contamination. Filters for each station should be stored on ice (if field filtered) in separate bags and frozen upon returning to the lab.

The remaining transect algal slurries are composited and a well-mixed subsample is taken for algal identification and enumeration. A 100 ml subsample is transferred to a 125ml Nalgene bottle and preserved with 3.5% Lugols (3.5ml) for algal identification and enumeration.

Labels for all processed samples should include station ID, date, subsample type (Chl-a, NC, P, Algal ID) and subsample volume. Total surface area for each transect (ea. 3 rocks $\times 18.1 \text{ cm}^2 = 54.3 \text{ cm}^2$), total transect volumes, chl-a subsample volumes, total composite volume, CN and P subsample volumes and algal ID volumes are recorded on the Periphyton Survey Data Sheet (Appendix 1).

Samples for the WQN/Nutrient Criteria Study or TMDL data collection should be shipped to the Penn State University Phycology laboratory. Filtered samples should be shipped frozen (dry ice) and algal ID samples should be shipped at room temperature. Chl-a, CN, and P samples should be shipped within 14 days of sampling and analyzed within 30 days of sampling. A shipping/chain-of-custody form will be made available to collectors.

QA – One replicate subsample will be collected for Chl-a, CN, P (transect A,B, or C) and Algal ID (composite) for every 10 stations sampled (10%) to examine subsample variability. Replicate information should be on the field form to the right of the routine volume information and marked with an R.



Figure 1. Pennsylvania Epilithic Periphyton Sampler.

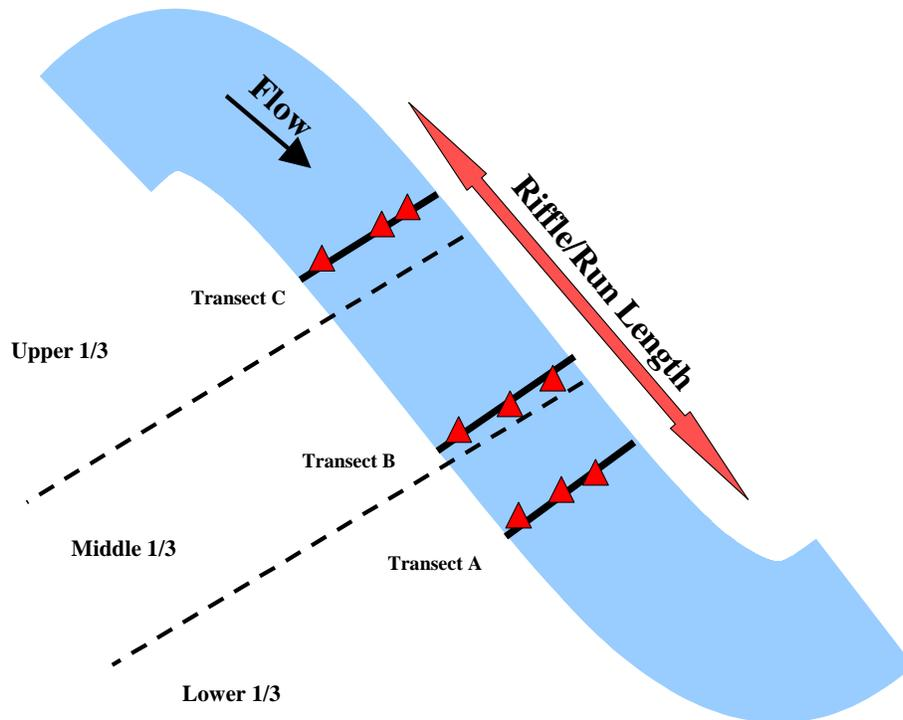

Figure 2. Schematic of nine rock, 3 transect composite sample in riffle/run.

Periphyton Field Description (Optional)

Biggs et al (2000) and Stevenson (1999) describe methods for rapid assessment protocols to quantify types of periphyton coverage. The procedure described here simplifies and borrows from Biggs (2000) Rapid Assessment Method 2 to provide a qualitative field description (%cover by type, color, growth form) of periphyton assemblages on substrates sampled for standing crop and species assemblage. This visual estimate of coverage will provide some description without significantly increasing sampling effort at each station. Visual descriptions may provide an inexpensive screening tool if they are found to correlate with periphyton standing crop. After collecting the three rock periphyton sample for a transect the collector estimates the percent coverage by algal type (to the nearest 10%) and dominant color of the attached algae based upon the periphyton field identification chart found in Appendix 2 (<http://www.niwa.cri.nz/ncwr/tools/periphyton>). Macrophyte coverage (ea. moss or river weed) should be noted. In addition to the visual description, photographs of representative rocks with the station and date identified on a 3X5 index card is also recommended to document periphyton conditions.

Physicochemical Site Conditions

Water Chemistry – Field measurement of Dissolved Oxygen, % DO, temperature, specific conductance, and pH should be conducted in the thalweg. Samples for nutrient analyses should be collected in the thalweg at mid-depth. One 500 ml Nalgene unfixed and one 125 ml Nalgene fixed with H₂SO₄ (pH < 2) are required for total phosphorous, (holding time = 28 days), total nitrogen (holding time = 28 days), and alkalinity (holding time = 14 days). Standard analysis code (SAC) 047 can be used for this parameter suite. Chemistry sampling should be conducted upstream of any disturbance associated with algal sampling.

QA – One field replicate chemical sample will be taken for every 10 stations (10%) sampled to examine sampling precision. Samples should be collected in a stream water rinsed 500 ml Nalgene bottle, mixed well, and subsampled by pouring into stream water rinsed sample and replicate bottles. One field blank chemical sample will be submitted to the lab for every 20 stations (5%) sampled to examine potential bottle contamination and lab errors.

Flow – If the sampling station is located at a USGS gaging station, stream discharge can be recorded from USGS gage data for the appropriate date and time. The instream discharge measurement methods described here are modified from Gordon et al (1992). A straight reach is chosen having relatively uniform depth, width, velocity and slope. Sites having back eddies, dead water zones or extreme turbulence should be avoided. A measuring tape is strung across the flow measurement transect (left bank to right bank) perpendicular to the flow and the stream is divided into subsections within which velocity and depth are measured along verticals at the midpoint. Depending on width, the stream can be divided into 0.5, 1, 2,3,4,or 5 foot subsections in order to obtain a minimum of 15 verticals. Subsection midpoint velocities are measured at four-tenths of the depth (0.4D) from the streambed for water depths less than 1.6 ft. Velocities are measured at 0.2D and 0.8 D when water depths are greater than 1.6 ft. Length of the subsection (ft) is multiplied by depth (ft) and velocity (ft/sec) to calculate the subsection discharge (cfs). Subsection discharges are summed to calculate stream discharge. Velocity measurements should be taken with the rod held vertically, the meter facing upstream, and the observer standing to the side of the meter and downstream.

Hydrologic Condition – High flows and resultant scour can significantly reduce periphyton standing crop in nutrient enriched streams. Nutrient / chl-a standing crop relationships have the potential to be obscured if periphyton is sampled directly after scour events. The collector will need to monitor regional weather and flow conditions and sample during extended dry periods. Biggs (2000) indicates that as much as four weeks of stable flow may be necessary for periphyton communities to regain biomass and species diversity that was present prior to a flood which caused bed load movement and subsequent scour. Biggs estimates scour inducing flows as 5 to 6 times the average flow for a given time period. Collectors can refer to USGS's PA gaging station web site which provides real time flow conditions that include average and median flow statistics (http://waterdata.usgs.gov/pa/nwis/current/?type=flow&group_key=basin_cd). Collectors should attempt to sample periphyton following at least 14 days of stable low flow conditions (dry weather). The collector should estimate and record the number of stable low flow condition days prior to sampling.

Stream Size – Two simple measures of stream size should be recorded. Determine the Strahler Stream Order for the sampling station from the Pennsylvania streams GIS layer or topographic maps. Measure the wetted width of the stream at each sampling transect and calculate an average width. Drainage area data is also available for WQN stations.

% Inorganic Substrate – Visually estimate (to the nearest 5%) the percentage of inorganic substrate sizes found in the sampled riffle/run. Assign a percentage to each of the seven substrate sizes so that they sum to 100%.

Canopy Closure / Canopy Density – In small streams, riparian leaf canopies can intercept 95% of incident solar radiation (Borchardt, 1996). Benthic algal standing crops, as chlorophyll-a, can be 4 to 5 times higher at open canopy sites than closed canopy sites (Hill, 1996). Additionally, during summer

conditions, East/West oriented streams can receive significantly more light than North/South oriented streams with similar canopy.

Stream orientation and canopy closure/density are measured with a compass and a Model C Concave Spherical Densimeter respectively. Facing downstream at midreach, midchannel, site the compass along the stream direction and orient the compass with magnetic north. Record the azimuth (horizontal direction in degrees) on the data sheet.

Methods for estimating canopy closure and canopy density follow Platts et al (1987). Vegetative canopy closure is the area of the sky bracketed by vegetation, whereas canopy density is the amount of sky blocked by vegetation. Canopy closure is measured during leaf-off and canopy density is measured during leaf-on. The densimeter's concave mirror surface has 37 grid intersections forming 24 squares. To eliminate bias from overlap, only 17 of the 37 grid intersections are used as recording points. The 17 grid intersections to be used are delimited by taping a right angle on the densimeter (Figure 3).

For smaller streams (Strahler Order 1 to 4) the densimeter is held in the hand on the midreach transect line, perpendicular to the right wetted edge of the stream, 1 foot from the shoreline and 1 foot above the water surface. The leveled (bubble level) densimeter is pointed toward the bank (taped right angle points toward the recorder) with the observer's head reflection near the top grid line. The number of line intersections (maximum of 17) that are surrounded by vegetation (canopy closure during leaf-off) or intercepted by vegetation (canopy density during leaf-on) are counted. This same procedure is repeated at midchannel looking upstream, midchannel looking downstream, and along the left bank shoreline. Canopy closure or density scores are summed and divided by 68 to calculate a percent closure or density. Right and left bank designations are determined when looking downstream.

For larger streams (Strahler Order 5 to 7) the same procedure is used except eight recordings are made so that shore/bank recordings do not over influence mid channel readings. In addition to right bank, left bank, and mid channel (upstream and downstream) recordings, recordings are also made at the $\frac{1}{4}$ and $\frac{3}{4}$ interval across the transect. Canopy closure or density scores are summed and divided by 136 to calculate a percent closure or density.

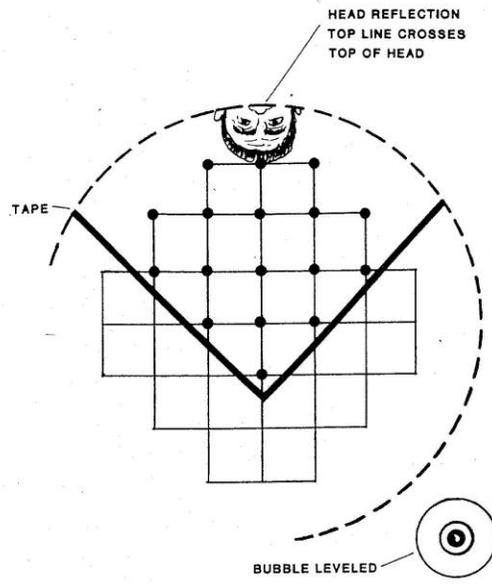

Figure 3. Concave spherical densiometer with placement of head reflection, tape and 17 observation points. From Platts et al. (1987).

References

- Barbour M.T., J. Geritsen, B.D. Snyder, and J.B. Stribling. 1999. Rapid Bioassessment Protocols for use in Streams and Wadeable Rivers : Periphyton, Benthic Macroinvertebrates and Fish, Second Edition. EPA 841-B-99-002. U.S. Environmental Protection Agency ; Office of Water; Washington D.C.
- Biggs B.J., and C Kilroy. 2000. Stream Periphyton Monitoring Manual. The New Zealand Ministry for the Environment, Christchurch, New Zealand.
- Biggs B.J. 1996 Patterns in Benthic Algae of Streams. In Algal Ecology, Freshwater Benthic Ecosystems (Edited by Stevenson P.J., Bothwell M.L., Lowe R.L., pp 31-56. Academic Press, San Diego.
- Borchardt, M.A. 1996 Nutrients. In Algal Ecology, Freshwater Benthic Ecosystems (Edited by Stevenson P.J., Bothwell M.L., Lowe R.L., pp 31-56. Academic Press, San Diego.
- Dodds, W.K., and E.B. Welch. 2000. Establishing nutrient criteria in streams. Journal of the North American Benthological Society 19 : 186-196.
- Gordon, N.D., T.A. McMahon, and B.L. Finlayson. 1992. Stream Hydrology, An Introduction for Ecologists. John Wiley & Sons, New York.
- Hill, W.R. 1996. Effects of Light. In Algal Ecology, Freshwater Benthic Ecosystems (Edited by Stevenson P.J., Bothwell M.L., Lowe R.L., pp 31-56. Academic Press, San Diego.

Moulton, S.R., J.G. Kennen, R.M. Goldstein, and J.A. Hambrook. 2002. Revised Protocols for Sampling Algal, Invertebrate, and Fish Communities as Part of the National Water-Quality Assessment Program. Open File Report 02-150, Reston Virginia.

Platts, W.S., E. Armour, G.D. Booth, M. Bryant, J.L. Bufford, P. Cuplin, S. Jensen, G.W. Lienkaemper, G. W. Minshall, S.B. Mosen, R.L. Nelson, J.R. Sedell, and J.S. Tuhy. 1987. Methods for Evaluating Riparian Habitats with Applications to Management. General Technical Report INT-221. USDA.

Stevenson, R.J. 1996. An Introduction to Algal Ecology in Freshwater Habitats. In Algal Ecology, Fresh Freshwater Benthic Ecosystems (Edited by Stevenson P.J., Bothwell M.L., Lowe R.L., pp 31-56. Academic Press, San Diego.

Appendix 1

PA DEP Periphyton Survey Data Sheet

Site Information

Station ID	
Chem ID	
Date	
Time	
Personnel	

Latitude (NAD 83)	
Longitude (NAD 83)	

Days of stable low flow conditions prior to sampling.	
--	--

Rock Substrate Sampling Information

	Transect A	Transect B	Transect C	Composite
Transect Width (m)				
Random Percentages	1) 2) 3)	1) 2) 3)	1) 2) 3)	
Collection Location	1) 2) 3)	1) 2) 3)	1) 2) 3)	
Surface Area (cm²)				
Total Volume (ml)				
Chl-a Volume (ml)				
Cellular P Volume (ml)				
Cellular N,C Volume (ml)				
Algal Id Volume				

Physicochemical Site Conditions

Stream Order	
% Inorganic Substrate	
Bedrock	
Boulder	> 10 in
Cobble	2.5-10 in
Gravel	0.1 - 2.5 in
Sand	0.06-2mm
Silt	0.004 - 0.06 mm
Clay	< 0.004 mm

Water Temperature	
Sp. Conductivity	
pH	
DO	
%DO	

Stream Orientation	
---------------------------	--

Spherical Densiometer	Canopy Closure Leaf-Off	Canopy Density Leaf-On	
Right Bank			
1/4 Interval Upstream			> 4th order
1/4 Interval Downstream			> 4th order
1/2 Interval Upstream			
1/2 Interval Downstream			
3/4 Interval Upstream			> 4th order
3/4 Interval Downstream			> 4th order
Left Bank			
Total			

Divide total by 68 (small streams-4 recordings) or 136 (large streams-8 recordings) to calculate percent canopy closure or density.

Discharge Measurement

Transect Width	
-----------------------	--

	midpoint	length(ft)	depth(ft)	velocity (f/s)	discharge (cfs)
1					
2					
3					
4					
5					
6					
7					
8					
9					
10					
11					
12					
13					
14					
15					
16					
17					
18					
19					
20					
				Total	

Periphyton Field Description (Optional)

Periphyton Description	Rock Number									
	Peri. Score	Transect A			Transect B			Transect C		
		1	2	3	1	2	3	1	2	3
Thin mat/film: green	7									
(under 0.5 mm) light brown	10									
black/dark brown	10									
Medium mat : green	5									
(0.5-3mm) light brown	7									
black/dark brown	9									
Thick mat : green	4									
(> 3mm) light brown	4									
black/dark brown	7									
Filaments, short green	5									
(< 2cm) brown/reddish	5									
Filaments, long green	1									
(> 2cm) brown/reddish	4									
Other (Moss, River Weed)										
Total		100	100	100	100	100	100	100	100	100

Notes

Algal Coverage – 0-25%__ 25-75% __ 75-100% __

Appendix 2 – Reprinted from Biggs and Kilroy (2000)

Stream Periphyton Monitoring Manual

Periphyton field identification chart. Part 1

(from the New Zealand Stream Health Monitoring and Assessment Kit)

For more information on each periphyton type, see page 45 in this Manual.

Thin mat or film (less than 0.5 mm thick)

Green



Light brown



Black/dark brown



Medium mat (0.5 to 3 mm thick)

Green



Light brown

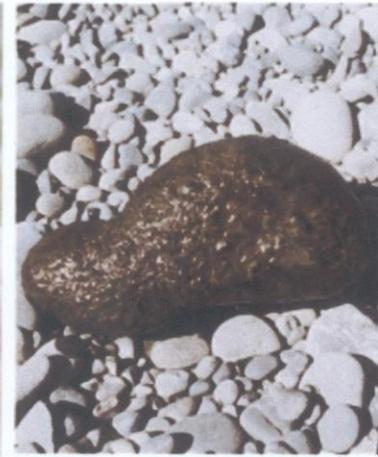

Black/dark brown



Thick mat (more than 3 mm thick)

Green

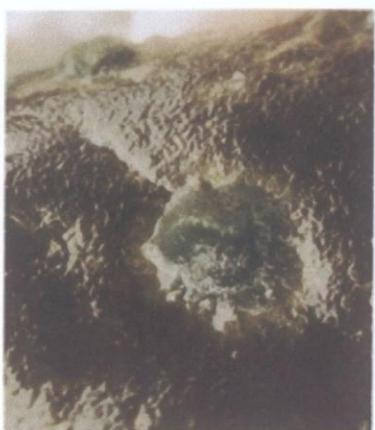

Light brown



Black/dark brown



Periphyton field identification chart. Part 2

(from the New Zealand Stream Health Monitoring and Assessment Kit)

Short filaments (less than about 2 cm long)

Green



Brown/reddish



Long filaments (more than about 2 cm long)

Green



Brown/reddish



Appendix D

DEPARTMENT OF ENVIRONMENTAL PROTECTION

Bureau of Point & Non-Point Source Management

Surface Water Collection Protocol

INTRODUCTION

As part of its water quality monitoring programs, the Pennsylvania Department of Environmental Protection (DEP) collects water chemistry data to assess the quality of the Commonwealth's water resources. This information is used to detect or confirm pollution sources and causes, for routine water quality monitoring, and for abiotic-biotic correlation.

This document provides guidelines for the standardized collection of water samples from wadeable surface water resources. The methods described here are adapted from scientific, peer-reviewed methods, and were developed by the Department's technical experts. This protocol does not attempt to describe the entire spectrum of water quality data-collection techniques (such as continuous instream monitors).

Changing trends in data management, aquatic sciences, and department programs emphasized the need to standardize the DEP's methods for collection of surface water samples. As the Department's water quality monitoring programs evolve to meet scientific advancements and environmental challenges, this "Methods" manual must be dynamic, and consequently subject to revision.

Because sampling situations may vary largely, no single water sampling procedure can be universally recommended. This document describes surface water sampling procedures appropriate for typical DEP investigations and may require modification as situations dictate. Variations to this protocol will be dependent upon site conditions, equipment limitations, or limitations imposed by the procedure. Investigators should document modifications and report the final procedures employed.

Investigators should be aware of, and work to mitigate, the potential for sample contamination at all phases of the sample collection process by observing proper sample collection, handling, and preservation methods described here. The most common sources of error (also known as "interference") are cross-contamination and improper sample collection and preservation.

The mention of specific trade names or commercial products does not constitute DEP endorsement or recommendation for use.

COLLECTION REQUIREMENTS

Collector Identification Number. Field staff required to collect surface water samples must have an assigned four-digit collector identification number (e.g., 0925). This number along with a sequential three-digit sample number (e.g., 0925-001), and date/time of sample are used to help identify individual samples. Supervisory staff can request collector identification numbers for their field staff with the "Collector ID Request Form" found at the Bureau of Laboratory's (BOL) website ([Lab Forms](#)).

Sample Information System (SIS) Requirements. Field staff must obtain a SIS login name and password in order to enter/edit sample information. SIS is an Oracle application that sample collectors use to store, manage, and retrieve sample information including sample results, sample medium, sample collection location, field parameters, quality control identification, general comment information, etc.

Field staff will need contact a system coordinator or eFACTS coordinator to obtain the correct SIS securities (see SIS Security Request Form, doc # 1300-FM-IT1016 SIS), which will allow them to

manage sample information in SIS. SIS securities are broken down into roles. Roles include (1) Querying, (2) Project Entry, (3) Monitoring Point Entry, and (4) Sample Entry. Each role is then applied to at least 52 specific programs or business units such as (1) Watershed Conservation, (2) Water Supply Management, (3) Land Recycling and Waste Management. Program or business unit names periodically change, pending reorganizations and other circumstances.

Field staff will need to have at least Querying and Sample Entry security roles for the program or business unit that they are collecting samples for. The program or business unit will be consistent with the Program Code entered on the “DEP Laboratory Submission Sheet”

DEP Laboratory Submission Sheet. Investigators must submit samples to the PA DEP Bureau of Laboratories (BOL) using the “DEP Laboratory Submission Sheet” ([Lab Forms](#)). Field staff are required to document collector identification number, reason code, cost center, program code, sequence number, date collected, time collected (in military time format), fixative(s), Standard Analysis Code (SAC), legal seal numbers for each sample collected (if required), the number of bottles submitted per test suite, collector name, date, phone number, and any additional comments that lab analysts will use to properly handle samples.

As described previously, collector identification numbers are unique to each field staff collecting samples. Reason codes, cost centers, and program codes are program specific and should be obtained from the program responsible for coordinating sampling efforts. Sample sequence numbers are three digit sequential numbers (001-999) unique to a sample collected on a given day generated by field staff collecting samples. Date and time collected should be accurately documented, especially if field parameters with specific diurnal fluctuations (temperature, dissolved oxygen) will accompany analytical results. If a sample is “fixed” or preserved with acid this must be documented in the appropriate space.

A standard analysis code or SAC is a unique code that details analytical tests to be applied to a specific sample. Each DEP program uses specific SACs for specific projects or purposes. For example, SAC 018 is used by “Water Management” when submitting water chemistry samples for Special Protection Surveys. The analytes/tests listed under SAC 018 are those specifically identified by regulations that surface water must meet and therefore be assessed for if a special protection determination is warranted. Other programs have developed unique SACs for their specific purposes, and the DEP BOL encourages programs to create SACs tailored to a program’s specific needs. SAC 100 is used as a “generic” identifier to indicate that a single analytical test is being requested. SAC 100 samples require additional information to be entered in the ‘Comment’ field (i.e. mercury only sample). To view the current list of SACs and suite codes available, refer to [Standard Analysis Codes](#).

Legal seals and associated legal seal numbers are required under circumstances where it is imperative to document the integrity of samples from sample collection to sample analysis. Legal seals are not always required, and should be used according to a program’s specific requirements. Legal seal numbers must be singly listed (include letter and number) for each sample. Legal seals can be obtained from BOL. Refer to BOL for more information concerning legal seals for your particular needs.

Collector Name, Date, Phone Number, and # of Bottles submitted were added to the “DEP Laboratory Submission Sheet” to meet NELAP chain-of-custody requirements. Using the area at the bottom of the form, each bottle submitted for the samples identified must be accounted for by enumerating the number of bottles per category listed for inorganic and organic analyses/tests. Each submitted form is also required to have printed the collector’s name, the date, collectors signature (Relinquished by:), and

collector's phone number. There are also spaces to document a facility name, facility identification number, and an alternate contact. These three pieces of information are not required.

The last piece of information to be documented is additional comments that lab analysts will use to properly handle samples. This information is documented in the 'Comment' field at the bottom of the form. The most common use of this field is to add or delete tests to or from a specified SAC. For example, SAC 018 does not include a test for turbidity; however, a sample collector needs to document turbidity for a particular sample. The sample collector would identify SAC 018 in the appropriate field and indicate in the 'Comment' field to add the turbidity test to the particular sample. If a large number of samples will be submitted with consistent modifications of a particular SAC, the BOL prefers a new SAC be created specifically for those samples. Other important comments to consider include identifying potentially toxic or otherwise dangerous samples, samples submitted for individual tests, and other important information that lab analysts will need to know to handle your samples correctly. The BOL recommends contacting the appropriate BOL staff before submitting samples requesting organic tests, potentially dangerous samples, or samples that need to be handled differently.

Sampling Supplies and Equipment. DEP programs can and do employ a multitude of program specific surface water sampling techniques that will require standard supplies (sampling bottles, preservatives, etc.), and can include specialized supplies (filters) or specialized equipment (Kemmerer, Van Dorn, etc.). This section describes the equipment and supplies required to collect the most commonly used sampling techniques and does not include all surface water sampling techniques that could be employed. Additional techniques are added as they become applicable and as standard procedures are formalized.

Many surface water samples are manually/directly collected instantaneous "grab" samples. Water samples should be collected before conducting other types of in-stream field work in the study reach, such as discharge measurements or benthic macroinvertebrate collection, in order to avoid disturbing the water column. Water samples are normally collected in High-Density Polyethylene (HDPE) or amber glass bottles (for organic compound analysis). Samples should be preserved immediately upon collection, if necessary, with the proper type and amount of chemical fixative (usually an acid to an amount where the matrix pH is less than 2.0 pH units) and should be cooled and held at $\leq 6^{\circ}\text{C}$ until receipt by the laboratory. The sample bottles should be labeled in accordance with the procedure described later in this document. The numbers and types of sample bottles field staff need for one water sample depend on the specific SAC. The bottles used for a particular sample are determined by the analyses required for that sample and the different types of preservation required for the analyses of interest. Additional information can be found by contacting the appropriate person under [Directory](#).

Most Commonly Used Equipment:

- Sample bottles (e.g, 500ml, 125ml, 125ml Bac-T, 40ml amber VOA with TFE septa caps)
- Preservatives/Fixatives (HNO_3 , H_2SO_4 , HCL , Ice)
- Sample filters (0.45 μ (micron), 0.10 μ)
- Filter equipment (squeeze bottle, surgical tubing, syringe)
- Field meter
- Sterile pipettes
- Coolers
- Field data sheets or notebook
- DEP BOL Sample Submission Sheets

- Ziploc bags (for bottles and/or sample submission sheets)
- Nitrile gloves
- Permanent markers
- Pencils
- Clear packing tape
- 0.1 molar HCl rinse (to decontaminate 1000ml squeeze bottle and pre-wash filters)
- Legal seals (if required)

Some chemical analyses require laboratory technicians to calibrate specialized laboratory equipment, prepare specialized reagents, or otherwise perform pre-analytical preparation before samples can be analyzed. If a collector is going to submit several samples involving specialized preparation (such as for bacteriological analyses, which involve agar plating), he or she should contact the appropriate technician at the laboratory to ensure enough time is allocated for the pre-test procedures. If the laboratory is not notified to expect a large volume of these samples, holding times may be exceeded and the sample may be voided.

Typically, a 500ml HDPE bottle is used for storing an unfiltered, non-chemically preserved sample for inorganic constituent analyses. Some of the common chemical analyses that are obtained from this sample bottle include (with holding times):

- pH (immediate)
- specific conductance (28 days)
- alkalinity (14 days)
- hardness (14 days)
- acidity (14 days)
- biological oxygen demand (48 hours)
- nitrate and nitrite (48 hours)
- sulfate (28 days)
- bromide (28 days)
- chloride (28 days)
- fluoride (28 days)
- turbidity (48 hours)

Normally, 125ml HDPE bottles are used for storing filtered or unfiltered, acid-preserved (1ml of 1:1 HNO₃) samples for total and dissolved metals analyses. However, it is important to note that ferrous iron is preserved with 1:1 HCl, not HNO₃. The 125ml HDPE bottles are also used for storing unfiltered, acid-preserved (2ml of 10% H₂SO₄) water samples for phosphorus and ammonia.

A sterilized 125ml bottle (with blue cap) containing pre-measured sodium thiosulfate preservative is used for bacteriological analyses (fecal coliforms, fecal streptococci, total coliforms, or total plate count). These bottles are prepared and provided by BOL. A separate laboratory sample submission form specifically for bacteriological analyses (1500-FM-LAB0151) must be submitted with any such sample. This form is available at the BOL lab form site.

Water samples collected for total or dissolved organic carbon or volatile organic compound analyses are stored in two 40ml VOA amber glass vials. Additional analyses may require other specialized containers, so it is important to check the BOL site when working with new analyses.

COLLECTION METHODS

Field personnel must ensure that the samples collected will be representative of the aquatic system of interest. A grab sample temporally and spatially represents the part of the surface water system being investigated. The method of sampling and constituents chosen for analysis is critically dependent on the purpose and scope of the survey being conducted. Obtaining representative samples is of primary importance for a relevant description of the aquatic environment. Interference of the sampling process must be minimized; collectors must be alert to conditions that could compromise the integrity of a water sample. The most common causes of sample interference during collection include poor sample-handling and preservation techniques, input from atmospheric sources, and contaminated equipment or reagents. Each sampling site needs to be selected and sampled in a manner that minimizes bias caused by the collection process and that best represents the intended environmental conditions at the time of sampling.

Before handling sample bottles, the collector should ensure his or her hands are clean and not contaminated from sources such as food, coins, fuels, mud, insect repellent, sunscreen, sweat, nicotine, etc. Alternatively, collectors should wear disposable, powderless gloves (such as nitrile).

Labeling Bottles. While the minimum required information is the collector number and sequential sample number, collectors should add additional information such as date and time collected, general test(s) description (total metals, etc.), “filtered”, and preservation indication. This will help prevent confusing what bottles are for which tests and to help ensure the sample is properly preserved. Labeling should be done so that at least 1” of space is left at the top of the bottle to allow BOL to apply lab labels.

Permanent marker will rub off of HDPE bottles during collection and transport. So, clear packing tape is wrapped around the bottle to protect the hand-written labels. Using ball-point and other non-permanent ink pens must be avoided. BOL discourages the use of masking tape. Collectors should keep a log book of all samples they collect, and should not re-use sequential numbers in order to avoid confusion. The sample log should annotate the unique collector identification and sample number, date and time, the water body name, sample location, SAC code, and any additional analytical tests performed or excluded. Additional information on labeling samples can be found on the BOL website.

Direct Surface Water Sampling of Wadeable, Flowing Water Bodies. The most common type of water sampling is conducted in wadeable, flowing water bodies, where the water sample is collected directly into the sample bottle. This method is not generally used in situations where contact with contaminants is a concern.

The collector should face upstream, taking care to not alter flow patterns or disturb substrate sediments upstream of where he or she will collect the sample. Collection bottles should be inserted into the water column vertically, facing down to avoid inadvertently collecting surface debris/films. In most situations, samples are collected at mid-depth in the approximate *thalweg* (the line defining the points along the length of a stream bed with the greatest depth). The collector should remove the stopper/lid from the sampling container just before sampling, taking care not to contaminate the cap, neck, or the inside of the bottle with his or her fingers, wind-blown particles, or dripping water from precipitation, clothes, body, or overhanging structures. All bottles are rinsed three times instream before filling the bottle. Once the sample is collected and capped, the collector should rinse any large amount of dirt or debris from the outside of the container.

Field Meters. Field meters provide the ability to collect in-situ data that is not available through grab samples submitted to BOL. Standard field parameters include dissolved oxygen, temperature, specific conductance, pH, and turbidity. While BOL does report pH, it is understood that the pH of a grab sample can and will migrate, and the lab result may not reflect the actual instream pH. Specific conductance is useful in several situations including determining complete mix of a receiving water body in relation to the location a sample collector chooses to collect a particular sample.

The use of a field meter, while not universally required, is highly recommended and will depend on the specific field survey protocol being used. Field meters should be calibrated with standard solutions within 24 hours of sampling and should be checked against standards after each sampling day in order to document any fouling or calibration drift that may have occurred throughout the day. It is also advisable to check against standards throughout the day if the meter reports unusual or unexpected values. Each field meter must have documentation that allows the user to track date and time calibrated/checked; before and after calibration readings for specific parameters with standard solutions; performance of various probes; and comments detailing the maintenance history of probes, certifications, or unique circumstances that could affect meter operation.

Collecting Unfiltered Samples. For unfiltered samples, the collection bottle is rinsed at least three times with the water to be sampled. The collector removes the lid from the bottle and partially fills the bottle under water. The bottle is then removed, capped above the water, shaken vigorously, uncapped, and inverted. Rinsing waste is discarded behind the collector to ensure no contamination reenters the sample bottle. Unfiltered, inorganic samples will be filled to the neck of the bottle, thus allowing for “head space” as requested by the BOL. Specialized bottles used to collect volatile samples, however, are filled to the top and capped so that no air remains in the bottle. It is imperative that the bottle is filled with water the same way every time to maintain consistency. The proper amount of reagent is then added; the bottle is recapped and then inverted several times to mix the reagent with the sample.

Collecting Filtered Samples. Filtered samples must be filtered and fixed immediately after sample collection using a 0.45 micron disposable (single-use, metals free) cartridge filter (AquaPrep 600 Groundwater Filters, VWR: #28145-142 or equivalent). Filters should be kept in their plastic shipping bags during use, with only the inlet and outlet nozzles (which are indicated by a directional flow arrow on the cartridge case) protruding. Filters should be rinsed with at least 500ml of trace-metal free deionized water. Rinsing removes trace contaminants (if any) from the manufacturing process.

For filtered samples, the collector uses a 500ml or 1000ml squeeze-type bottle to collect the sample. Prior to collecting the water, the collector rinses the squeeze bottle three times in the same manner as for an unfiltered sample. Using surgical tubing, the inlet nozzle of the pre-rinsed filter is attached to the squeeze bottle after the sample is collected and approximately 200ml of stream water is squeezed from the bottle through the filter. The bottled labeled for the filtered sample is then placed under the filtered cartridge effluent and is rinsed with the filtered sample three times in the same fashion. As with the unfiltered 125ml sample, the water sample in the bottle is filled to the neck of the bottle. It is imperative that the collector accurately fills water to this line to ensure consistency of dilution of the fixative between samples. If the collector is not consistent in performing this quality assurance step, his or her dissolved constituent concentrations may exceed the equivalent total constituent concentration in the unfiltered sample. The reagent preservative is added and mixed as for unfiltered samples.

For samples requiring a duplicate, such as for TOC or DOC, the collector should use a 125ml glass bottle to dispense and fix the sample, then split the sample into the two 40ml amber vials. Filling and

fixing each 40ml vial independently will invariably yield variation between the duplicates. This 125ml glass bottle should be decontaminated before each sample with a small amount of H₂SO₄ followed by rinsing with “ultrapure” water. As long as the lids on the 40ml vials have not been opened, they are not required to be pre-rinsed. The caps, however, usually collect potential contaminants while in storage (i.e., dust), and should be cleaned before opening the vial.

Other bottles are available for purchase as certified metals-free. These bottles should not need pre-rinsing unless the caps have fallen off in transit, or were accidentally dropped during handling.

Preservation. Without preservation, water sample constituents will continue chemical interactions or otherwise undergo other physical processes, such as metals precipitation. Moreover, laboratory pH measurements are usually higher than field measurements because of carbon dioxide degassing from the matrix. Keeping the water samples at 4°C helps minimize this process and slows other reactions that may occur. Most chemical preservatives function by decreasing the matrix’s pH below 2.0 (or above pH 12 for cyanide - fixed with NaOH), which limits further constituent reaction.

Reusing graduated glass pipettes with a manually-controllable pipette may be necessary at times, but the collector should understand that doing so introduces potential for contamination at several points in the preservation process. The pipette must be carefully guarded against contacting any surface and should be cleaned between uses. The preservative contained in the bulk storage container will likely become contaminated from constant opening and insertion of the pipette.

As noted earlier, most metals are preserved using concentrated HNO₃. *HNO₃ is highly reactive—even in small amounts—and will cause chemical burns to exposed skin and damage metal and clothing.* This preservative can be purchased in individual 1ml glass ampoules, plastic vials with twist-off caps, or in bulk supply (to be dispensed via graduated pipette). The glass ampoules require breaking the tip; the potential for skin laceration is present, and the collector must invert the ampoule and tap the bottom several times to dispense the preservative. Many collectors prefer the plastic twist-cap vials because the liquid preservative dispenses more readily and the potential for laceration from broken glass is avoided.

Specific Considerations. In general, collectors should avoid sampling in eddies, pools, side-channels, or in tributary mixing zones unless necessary due to site-specific or other environmental considerations. Collectors must also be aware of potential point-source and non-point sources of water quality influence.

For slow moving streams with easily disturbed sediment, the collector should sample from the stream bank, boat, or bridge using a sampling extension pole. If sampling from a boat, the collector should sample near the bow as the boat moves upstream or faces upwind.

For point source surveys and characterizing other influences, representative water samples are collected from the discharge pipe/influence, from upstream (control), and downstream locations at a minimum. Sampling stations located upstream of the discharge pipe should be in a non-impacted zone to serve as a control. If there are multiple discharges, then sample stations should be placed to bracket individual discharges in order to better characterize each source. For sampling downstream of the discharge pipe, the investigator should avoid the immediate vicinity of the discharge/influence point and select a sample point far enough downstream to allow for mixing between the discharge and stream flow.

To decide where an acceptable downstream sampling point should be located, consider the following. For pollutants controlled by acute concerns, enforcement of numeric criteria is at the point of complete

mix, or after 15 minutes of mixing, whichever occurs first. For pollutants controlled by chronic concerns, enforcement of numeric criteria is at the point of complete mix, or after 12 hours of mixing, whichever occurs first. These are all projections at design conditions (Q7-10 or harmonic mean flow). The actual point of complete-mix depends on the stream size, its width and depth, its flow on that day, the velocity of the plume, the angle at which it enters the stream, and the roughness of the stream bed.

Conductivity measurements may help determine the point of complete mix. If the point of complete mix is unclear or too far downstream for representative sampling, then multiple samples should be collected across a transect. For very large streams and rivers it may be necessary to composite samples collected along a cross channel transect to accurately characterize water quality of the sampled stream segment (PA DEP, 2009).

For storm water surveys, a minimum of one sample is collected during low or dry weather flow to determine background conditions and from 3 to 5 high flow (storm) events in conjunction with stream flow measurements to characterize pollutant loadings. For storm events it is important to make collections during the first flush and/or while the hydrograph is rising. Analyses should be performed for metals (Fe, Al, Cu, Pb, Zn, Cd, Cr, Hg), oils and grease, pathogens, and for total and dissolved nutrients. Analysis is not limited to the above and parameters of special concern (e.g. fertilizers, pesticides and other organic chemicals) may be added as necessary (PA DEP, 2009).

If deemed necessary by the investigator, nutrient sampling will occur during the growing season at least once a month from May through October. Sampling should occur during both dry and wet weather in order to adequately characterize loadings. Wet weather samples should be collected during the rising hydrograph. In addition, stream discharge will be measured at least once. Water quality analyses should be conducted for total and dissolved nutrients using SAC 047 (PA DEP, 2009).

For abandoned mine discharges or acid mine discharges, samples should be collected from the point(s) of discharge, if possible. In addition, flow from the discharge(s) should be measured to determine loading rates for TMDL development. Flow and channel cross section are measured in the field according to standard USGS stream gauging techniques (USGS, 2006). Analyses are performed for metals, alkalinity, and acidity using SAC 909 (PA DEP, 2009).

Acid precipitation sampling should occur in late winter/early spring during heavy snowmelt and/or storm events to capture episodic acidification. Sampling should occur during both base flow and peak flow to characterize worst-case conditions and to document the difference between base flow and worst-case conditions. This protocol includes a filtering method for dissolved aluminum that differs from that prescribed for other dissolved metals. Water for the dissolved aluminum analysis is filtered through a 0.1micron filter rather than through the standard 0.45micron filter. The result from this alternate dissolved aluminum analysis correlates well with the occurrence of inorganic monomeric aluminum species, which causes lethal responses in fish. Analyses are performed for metals, alkalinity and acidity using SAC 910 (PA DEP, 2009).

For surface waters used as sources of drinking water, the potable water supply use can be evaluated by collecting samples upstream of the surface water withdrawal at a minimum of one location; however, multiple locations may be necessary to identify potential sources of pollution. Analyses are performed for total nitrites, iron, manganese, chloride, fluoride, sulfate, color, and dissolved solids using SAC 166. Additional microbiological parameters can be added on a site-specific basis (PA DEP, 2009).

Quality Assurance. For quality assurance purposes, sample blanks containing “ultrapure” water obtained from BOL should be submitted for every 20 samples for each sampling trip/day to determine whether contamination is occurring in any part of the sample collection, handling, or preservation process. A duplicate grab sample should also be collected every 20 samples or for each sampling trip/day to gauge testing variability and potential sources of contamination due to collection procedures. Duplicate samples are collected simultaneously or sequentially with the associated environmental sample, using identical sampling and preservation procedures. Sequentially collected duplicates may measure inhomogeneities present in the water body. Both sample blanks and sample duplicates are assigned unique, sequential sample numbers. The collector needs to carefully annotate which sample is a duplicate or blank. Duplicates and blanks must be documented appropriately in SIS under the ‘Comments/Quality Assurance’ tab.

Sample Holding Times. Water samples need to be shipped or delivered to the lab as soon as possible. The collector should understand that certain laboratory analyses have “holding times” during which tests must be conducted for result validity. Nitrate concentrations, for example, must be measured within 48 hours of sample collection. If a sample exceeds holding time requirements the results will not be reported unless a “Request to Analyze Voidable Samples” form (see the BOL website) is submitted to the Bureau of Laboratories. *It is not advisable to collect and ship samples on Fridays*, as the laboratory does not operate on weekends; samples shipped on Friday will not be received and logged until Monday morning. Doing so will guarantee that holding times of 48 hours or less will not be met. Collectors essentially need to plan their water sampling from Monday through Thursday, dropping off samples collected those days by 1600 hours, and verify shipped samples will reach DEP BOL by early Friday morning at the latest. Samples collected for CBOD and BOD analyses have a 48 hour holding time. Holding time begins at the time of sample(s) collection. Initial DO is not performed on CBOD/BOD samples until Wednesday due to the five day incubation period. If samples must be collected on Mondays, collect the samples after 1:00 pm to ensure the test is within holding time.

Shipping. All DEP district and regional offices are designated pick-up locations for water samples; the samples must be dropped off for pick up by 1600 hours. Other locations exist, such as at some Pennsylvania Department of Transportation facilities and some private businesses, but these drop-off locations may require call-ahead notice to the current courier, as they may not be visited daily. Further, the drop-off locations may require a drop-off specific key to open the drop-off entrance lock.

The collector should vertically insert bottles into a cooler, right-side up. The samples should be cooled with cubed or crushed ice. A sufficient amount of ice should be added to the cooler to ensure samples remain at 4°C during overnight shipping. Laboratory personnel will note whether samples were shipped properly. Improperly shipped samples may be subject to a data release request. Dry ice will freeze water samples and should never be used for storage or shipping. The “Sample Submission Sheet” should be filled out, inserted into a Ziploc bag, and attached to the inside of the cooler lid. Courier shipping labels should be printed out during ordering so they can be attached to the top of the cooler lid during sample drop-off. Shipping labels are secured to the cooler lip with two pieces of packing tape on the left and right side; taping all sides of the label makes removal difficult for lab technicians.

SAMPLE INFORMATION SYSTEM (SIS) DOCUMENTATION

SIS is an Oracle application that sample collectors use to store, manage, and retrieve sample information, including sample results, sample medium, sample collection location, field parameters, quality control identification, general comment information, etc. Sample collectors, at the very least,

must have security roles for their program to perform Sample Entry and Querying. Samples submitted to the BOL will have the following information populated in SIS: collector identification number, sample sequence number, sample time and date, and sample results. It is the responsibility of the sample collector to populate, at the minimum, sample medium, sample collection location, field parameters, quality control identification, and general comment information.

SIS can be accessed through the DEP intradep website by selecting 'Oracle Applications'. DEP maintains several Oracle applications, so users must select 'SIS - Samples Information System'. Users will be prompted to enter a unique (CWOPA) username and password, in addition to a database identifier. The database identifier is 'prod'. Samples can be entered into SIS by the sample collector before or after BOL populates sample results. It is important to enter the collector identification number, sample sequence number, and date and time collected correctly. If samples are entered into SIS before BOL populates sample results these attributes will be used to associate sample results. If samples are entered after BOL populates samples results, the sample collector will need to query in order to find the sample and populate attributes. The following is a truncated step-by-step process outlining how and what to enter for each sample collected. Additional information is available through the 'Sample Information Users' Guide'.

I. Sample Entry

- A. Select Samples and Sample Entry from the SIS menu.
- B. Select the Business Unit that the sample was collected for and select 'OK'. If you do not see the correct Business Unit, you may not have the correct security roles. You will need to contact a system coordinator or eFACTS coordinator to complete a SIS Security Request Form.

II. To enter a sample before BOL populates sample results.

- A. Select 'Create New Sample'
- B. (Required) Enter the four-digit collector number assigned to the employee, group, or monitoring device that collected the sample. Press the [TAB] key.
- C. (Required) Enter the date the sample was collected (format MM/DD/YYYY). Press the [TAB] key.
- D. Enter the time the sample was collected in military time (ex. enter 1:00 pm as 1300). Press the [TAB] key.
- E. (Required) Enter the sequence number for the sample. Press the [TAB] key.
- F. (Required) The reason defaults to "Routine Sampling". Update the reason, if applicable.

III. To enter a sample after BOL populates sample results.

- A. Select the File Menu option at the top of the screen and check the 'view all samples' box.
- B. Click the  button on the toolbar or press the [F7] key.
- C. Enter the four-digit collector Id assigned to the employee or monitoring point that collected the sample or select using the  button. Press the [TAB] key.
- D. Enter the date that the sample was collected. Press the [TAB] key twice (2x).
- E. (Optional) Enter the sequence number assigned to the sample.

- F. Click the  button on the toolbar or press the [F8] key.

Once the sample header information has been entered or the sample has been successfully queried, proceed with Linking the Sample to an Existing Project, Facility, and/or Monitoring Point (IV) or Insert Location Details (V). This document does not characterize creating new projects, facilities, or monitoring points. For more information see ‘Sample Information System User’s Guide’.

IV. Linking the Sample to an Existing Project, Facility, and/or Monitoring Point

- A. Click the  TAB label.

Project/Facility/Monitoring Pt		Name & Address	Sampling Conditions
Location		Comments/Quality Assurance	Field Tests
Project Unit	<input type="text"/>	<input type="text"/>	<input type="text"/>
Project ID	<input type="text"/>	<input type="text"/>	<input type="text"/>
Primary Facility	<input type="text"/>	<input type="text"/>	<input type="text"/>
Sub-Facility	<input type="text"/>	<input type="text"/>	<input type="text"/>
Monitoring Point ID#	<input type="text"/>	<input type="text"/>	<input type="text"/>
Monitoring Point Alias	<input type="text"/>	<input type="text"/>	<input type="text"/>

- B. If the sample was collected for an existing project, complete the following steps:
1. Enter the code identifying the project’s business unit or select using the  button. Press the [TAB] key.
 2. Enter the identification number assigned to the project or select using the  button.
- C. If the sample was collected to monitor an existing primary facility and/or sub facility, complete the following steps:
1. Click in the *Primary Facility* field.
 2. Enter the program-specific identification number assigned to a primary facility. Press the [TAB] key.
 - i. OG – API Well Number (Permit Number)
 - ii. Mining – Permit Number
 - iii. RPX – Registration Number
 - iv. RPNARM – License Number
 - v. WPC – NPDES Id
 - vi. AQ –Tax Id-Plant Code
 - vii. WM – Permit Number
 - viii. WRWOB –WOBS File Id
 - ix. LR – LRP Id
 - x. STSTS – Facility Id

- xi. SDW –Public Water Supply Id
 - xii. WRDS –DAMINV Dam Id
- OR

3. Select the primary facility by clicking the  button, entering the name or program to limit the list, clicking the ACCEPT button, highlighting the primary facility on the list, and clicking the OK button. Press the [TAB] key.
4. Select a sub facility by clicking the  button.

- D. If the sample was collected at a particular monitoring point, complete the following steps:
1. Click in the *Monitoring Point Id#* field.
 2. Enter the identification number assigned to the monitoring point. Press the [TAB] key.

OR

- i. Click in the *Monitoring Point Alias* field and enter the alias assigned to the monitoring point. Press the [TAB] key.

OR

- ii. Click the  button to the right of either Monitoring Point field, enter the latitude and longitude to limit the list, click the ACCEPT button, highlight the monitoring point on the list, and click the OK button.

V. Insert Location Details. This section is used to identify the location at which the sample was collected. The latitude, longitude and datum are required in order to link and NHD record to the sample. If a sample is linked to a monitoring point on the Project/Facility/Monitoring Pt TAB, the locational information for the monitoring point will “automatically” display.

- A. Click the  TAB label.

Project/Facility/Monitoring Pt	Name & Address	Sampling Conditions
<u>Location</u>	Comments/Quality Assurance	Field Tests
State <input type="text"/>	<input type="text"/>	Auto-Fill
County <input type="text"/>	<input type="text"/>	
Municipality <input type="text"/>	<input type="text"/>	
Quadrangle <input type="text"/>	<input type="text"/>	
Latitude <input type="text"/>	UTM Zone <input type="text"/>	Nothing <input type="text"/>
Longitude <input type="text"/>	Easting <input type="text"/>	
Datum <input type="text"/>	<input type="text"/>	
Location Method <input type="text"/>	<input type="text"/>	
Location <input type="text"/>		
GET / VIEW NHD DATA		

- B. Click the  button (The county and municipality will display based on the linked primary facility, sub facility, or monitoring point). If the county and municipality does not display, complete Steps c through e; otherwise, proceed to Step f.
- C. The state defaults to “PA”. Update if necessary. Press the [TAB] key.

- D. Select the county.
1. Enter the code identifying the county in which the sample was collected. Press the [TAB] key 2 times.

OR

2. Press the [TAB] key and enter the name of the county. Press the [TAB] key.
OR
 3. Select by using the  button. Press the [TAB] key.
- E. Select the municipality.
1. Enter the code identifying the municipality in which the sample was collected. Press the [TAB] key 2 times.
OR
 2. Press the [TAB] key and enter the name of the municipality. Press the [TAB] key.
OR
 3. Select by using the  button. Press the [TAB] key.
- F. Select the quadrangle.
1. Enter the code identifying the quadrangle at the point where the sample was collected. Press the [TAB] key twice.
OR
 2. Press the [TAB] key and enter the quadrangle name. Press the [TAB] key.
OR
 3. Select by using the  button. Press the [TAB] key.
- G. (Required to insert NHD) Enter the latitude where the sample was taken (format Degree-Minutes-Seconds). Press the [TAB] key.
- H. (Required to insert NHD) Enter the longitude where the sample was taken (format Degree-Minutes-Seconds). Press the [TAB] key 4 times.
- I. (Required to insert NHD) Enter 'NAD 83' as the horizontal reference datum used to calculate the point at which the sample was collected or select by using the  button. Press the [TAB] key.
- J. Enter the method used to identify the point at which the sample was collected or select by using the  button. Press the [TAB] key.
- K. Enter a description of the location at which the sample was collected.

VI. Creating a New NHD Record and Linking to the Sample. If the sample is associated with a monitoring point, the NHD record for the monitoring point will “automatically” display for the sample and cannot be updated. Therefore, this procedure cannot be completed. This section identifies the steps for inserting a new NHD record for a sample.

- A. Click the **GET/VIEW NHD DATA** button at the bottom of the Locations TAB. The NHD Pop-Up Window will display.

- B.
- C. Click the **Launch NHD Locator** button at the bottom of the screen.

Map	Snap Point	County	Minor Civil Division	Hydrologic Unit Code	Stream Name	NHD Reach	NHD Measure	Stream Side
Delete	1	Northampton	UPPER MT BETHEL	02040105	Delaware River	02040105000218	50.768	

- D. Use the NHD Locator Tool to either accept the default snapped point or create a user-defined, new snapped point to accept. Reference the NHD Locator Tool User Guide for the steps.
- E. Click the **ACCEPT SNAPPED POINT(S)** button and then click the **OK** button to exit the NHD Locator Tool and return to the **SAMPLE ENTRY** Screen.
- F. Click the **Get NHD Data** button to add the NHD record created via the NHD Locator Tool to the sample.
- G. Click the **Close** button to return to the Locations TAB.

VII. Inserting Field Tests. This section is used to identify the types of tests conducted in the field on the sample.

A. Click the **Field Tests** TAB.

Project/Facility/Monitoring Pt	Name & Address	Sampling Conditions
Location	Comments/Quality Assurance	Field Tests
Field Test Description	Result Amount	Units
pH By Color	<input type="text"/>	pH units
pH By Meter	<input type="text"/>	pH units
Temperature	<input type="text"/>	C
Dissolved Oxygen	<input type="text"/>	MG/L
Specific Conductance	<input type="text"/>	umhos/cm
Iron By Color	<input type="text"/>	MG/L
Manganese By Color	<input type="text"/>	MG/L
	<input type="text"/>	
	<input type="text"/>	

B. Use the scrollbar to locate the field test for which you have results.

1. The list of field test will vary based on Business Unit.

C. Click in the *Result Amount* field.

D. Enter the amount for the test. Press the [TAB] key.

E. Update the unit of measurement if necessary.

F. Repeat Steps B through E until all applicable field tests are entered.

VIII. Inserting Sample Conditions. This section is used to enter the conditions under which the sample was collected.

A. Click the **Sampling Conditions** TAB.

Project/Facility/Monitoring Pt	Name & Address	Sampling Conditions
Location	Comments/Quality Assurance	Field Tests
Medium Type	<input type="text"/>	
Medium	<input type="text"/>	
Initial Flow	Final Flow	Units
<input type="text"/>	<input type="text"/>	<input type="text"/>
		Determination
		<input type="text"/>
Stream Condition	<input type="text"/>	
Depth To Water	Units	Determination
<input type="text"/>	<input type="text"/>	<input type="text"/>
		<input type="checkbox"/> Well Purged

B. (Required) Enter the code that identifies the type (category) of sample medium (soil, water, air, plants, etc.) or select by using the  button. Press the [TAB] key.

C. (Required) Enter the code that identifies the sample medium or select by using the  button. Press the [TAB] key. *Water samples collected from a stream or lake must have a sample medium of 'Surface Water'.

IX. Inserting Comment/Quality Assurance Details. This section is used to enter the comments and quality assurance details regarding the sample

A. Click the  TAB.

Project/Facility/Monitoring Pt	Name & Address	Sampling Conditions
Location	Comments/Quality Assurance	Field Tests
Appearance <input type="text"/>		
Comment <input type="text"/>		
Quality Assurance Type <input type="text"/>	Duplicate of Sample (Collector, Seq#, Date & Time) <input type="text"/>	
Confidentiality Reason <input type="text"/>	Void Sample <input type="checkbox"/> Dry Sample <input type="checkbox"/>	

- B. Enter a description of the sample's appearance. Press the [TAB] key.
- C. Enter any additional information regarding the sample. Press the [TAB] key.
- D. Enter the quality assurance type (duplicate, blank, or spike).
- E. If a duplicate, click the  button, enter the Id of the collector for the duplicate sample, enter the date the duplicate was collected, and click the ACCEPT button.
- F. Select the confidentiality reason (private water supply or legal enforcement action).
- G. If the sample is to be voided due to quality assurance reasons, click in the *Voided Sample* checkbox until a checkmark displays.
- H. If the sample is to be dry, click in the *Dry Sample* checkbox until a checkmark displays.
- I. Click the  button on the toolbar or press the [F10] key.

REFERENCES

- Pennsylvania Department of Environmental Protection. 2009. Instream Comprehensive Evaluation Surveys. Harrisburg, PA. URL: <http://files.dep.state.pa.us/Water/Drinking%20Water%20and%20Facility%20Regulation/WaterQualityPortalFiles/Methodology/ice_2009am.pdf>, accessed March 13, 2012.
- United States Geological Survey. 2006. National Field Manual for the Collection of Water Quality Data. U.S. Geological Survey, Water Resources Office of Water Quality. Chapter 4.1 - Surface Water Sampling: Collection methods at flowing-water and still-water sites. URL: <<http://water.usgs.gov/owq/FieldManual/chapter4/html/4.1.1.html>>, accessed September 23, 2008.

SAMPLING GEAR CHECKLIST

WATER SAMPLING

Sample containers:

- 500 ml sample bottles - inorganic, total metals, cyanides, phenolics?, other
- 125 ml sample bottles - dissolved metals
- 1000 ml amber glass bottles - organics: semi- volatiles, pesticides, PCBs
- 40 ml glass vials - organics: VOAs
- 125 ml bac-t³ (blue top) - bacteriological analysis (coliform & strep)
- other: _____

Fixatives:

- HNO₃ - ampules; total & dissolved metals
- other: NaOH, HCl, H₂SO₄

Field meters & related supplies:

- dissolved oxygen meter
 - replacement membrane kits
 - DO probe solution
 - zero % calibrating solution (if applicable)
- pH meter
 - buffers (pH 4, 7, 10)
 - KCl probe solution
- conductivity meter
 - calibrating solution (if applicable)
- thermometer (manual)
- meter field manuals (if applicable)

Other:

- Gelman .45 μ ground water filters
- DI water (lab tested)
- soda water
- pipetter & pipettes
- buckets & rope (applicable length for bridge sampling)
- shipping coolers
- rinse squirt bottle
- eyewash bottle

CHLORINE DEMAND

- chlorine meter & 10 ml vials
- reagents
- timer
- 2 - 1000 ml flasks & stoppers
- 2 - 500 ml flasks & stoppers
- pipetter & pipettes
- fresh bleach or pre-mixed dosing solution (& brown bottle)
- field instructions
- chlorine demand-free DI water

FLOW

- flow meter
- rods (for anchoring tape bank-to-bank)
- tape measure
- wading rod

FORMS

- laboratory water chem. sheets
- bac-t³ forms

- physical data field forms
- flow field form
- habitat assessment forms
- surface waters assessment (UW) forms
- chlorine demand forms
- other: _____

BENTHIC MACROINVERTEBRATES

- sample containers
- vials
- sampler: _____
 - D-frame net
 - Kick-screen
 - other: _____
- #30 sieve
- bucket
- forceps
- preservative: _____

FISH

- backpack shocker 2-cycle gas/oil mix
 - probes
- nets
- bucket(s)
- specimen jars
- preservative: _____
- block nets (if applicable)
- measuring board (if applicable)
- live bags (or suitable containers, if applicable)
- scale
- tow boat generator
 - probes
 - 4-cycle gasoline
- ear plugs
- polarized sunglasses

Tissue Collection related equipment:

- hexane filet knife
- foil dry ice coolers

SHIPPING

- courier shipping forms
- tape & dispenser

MISC.

- hip boots
- waders
- gloves (winter ___ electrofishing ___)
- markers, pens, & pencils
- map wheel
- calculator
- insect repellent
- screwdriver/tools
- batteries (D-cell, other: _____)
- other: _____

Appendix E

**DEPARTMENT OF ENVIRONMENTAL
PROTECTION**

**Bureau of Point & Non-Point Source
Management**

**Wadeable Semi-Quantitative Fish Sampling
Protocol for Streams**

Introduction

Pennsylvania's water quality monitoring program has relied on benthic macroinvertebrate protocols to conduct aquatic life use assessments for most of the state's wadeable streams. However, these benthic community methods can be difficult to apply to larger wadeable streams and rivers when benthic macroinvertebrate methods provide the best assessment resolution, which is late fall through early spring. PA DEP has already developed a preliminary semi-quantitative fish IBI (index of biological integrity) for wadeable warm water streams in the upper Ohio River basin of Pennsylvania, and additional efforts are also underway to determine the feasibility of wadeable warm water IBI for the remainder of the state. Aside from developing an IBI as an assessment tool, the standardized sampling methodology can be applied to all wadeable streams for the purpose of developing future indices and other assessment methodologies, promoting trend analyses over time, developing more accurate identifications and subsequent community structure assessments, and overall promoting a more comprehensive fish program.

Sampling Procedures and Requirements

The objective is to acquire a representative sample of the fish population in a wadeable stream or river by sampling all physical stream habitats in relative proportion to their availability. The collected sample will contain most of the species in the stream at the time of sampling in numbers proportional to their actual abundances. Field sampling methods, species identification and enumeration, and other site tasks must be applied consistently with the same level of rigor at each sample site. Accurate species level identification of each fish collected is essential. At least one crew member must be proficient in accurate identification of Pennsylvania fishes. Electrofishing crews will have a Crew Leader trained and experienced with proper operation of electrofishing gear and appropriate electrofishing tactics for wadeable streams. Sampling effort is often measured by distance, but the accumulated electrofishing time is an important indicator of adequate effort. Accumulated electrofishing time can legitimately vary over the same distance as dictated by cover, stream conditions, and the number of fish encountered. While it is understood that some individual fish will not be captured, a concerted effort by the crew members should be made to capture every fish sighted. Since the ability of the netters to see stunned and immobilized fish is partly dependent on water clarity, sampling is to be conducted only during periods of "normal" water clarity and flows. Since the sampling period is from May through October, a wide variety of stream flow conditions may be encountered. Periods of high turbidity and high flows should be avoided due to their negative influence on sampling efficiency. If high flow conditions occur, sampling must be delayed until flows and water clarity return to seasonal, low flow norms. The Crew Leader will decide if conditions are acceptable and direct their crews to exert the effort necessary to ensure a representative sample is collected.

For semi-quantitative sampling, a minimum site length of 100 meters should be surveyed (Table 1). Site length can be increased as necessary to cover all habitats (pools, riffles, runs, and cascades). Warm water streams require additional effort due primarily to the higher number of species and individuals present. Minimum site lengths for wadeable streams are based on average stream width and are summarized below. The starting point is first determined and marked on a USGS 7.5' topographical quadrangle map or with a GPS. In the first 100 meters, 5 wetted channel widths are measured using a graduated measuring tape or a range finder (every 20 meters from the starting point) and averaged. If the site length cutoff listed falls in the middle of a habitat sequence, or excludes a habitat type, then the upstream cutoff must be extended to include the sequence or missing habitat type.

Table 1. Reach lengths.

Average Stream Width (m)	Minimum Site Length
<10m	100m
10 to 40m	10 X average stream width
>40m	Maximum of 400m

For example: The average stream width is 14 meters. Minimum sampled length would be 140 meters. However, the 140 meters mark falls about 5 meters short of the head of the pool. The upstream cutoff would need to be extended to the head of the pool for a total sampled length of 145 meters. The reach length decision should be based on distance necessary to cover all habitat types. If the field reconnaissance is done close to the time of sampling, the appropriate reach length can be determined and marked off using a highly visible marker such as blaze-orange ribbon or surveyor's flags. For larger streams, it may be necessary to use a combination of electrofishing gear. The concept of the field sampling protocol is to attempt to collect every fish in the reach in order to produce a representative sample. A larger stream could be sampled with a backpack and towboat in tandem. A less preferred method would be to sample half the width of the stream for the reach length with a towboat and return to the start of the reach and sample the other half of the stream. A crew large enough to sample the full width of the stream in one pass is preferred because it reduces the chances of fish escaping to non-electrified sections of the stream reach. Further, if the crew is small, it will be more difficult to adequately handle and process the fish. Desk top and field reconnaissance should correctly assess crew and gear needs, but stream conditions change and the Crew Leader must make the final decision in the field. Crew Leaders will not sample if they believe a representative sample cannot be collected.

Wadeable or Non-Wadeable

Wadeable stream sites are limited to streams that would normally be wadeable for an extended period during the sampling window of May through October. The sample site or the wadeable reach must be representative of the general condition of the stream in that area. It cannot be an isolated wadeable reach within a section of stream that is not wadeable. The selection of wadeable sites will be determined by desk top reconnaissance and field reconnaissance. A wadeable reach is a reach that the field crew can sample with the expectation that they can collective every fish in the reach. There may be small areas of pools or holes along a bank that cannot be waded safely, but that the crew can surround and collect the majority of fish. This should be determined during field reconnaissance, but again the Crew Leader will not sample a reach if a representative sample cannot be collected.

Sampling Procedures

Cold water wadeable stream size starts at first order and warm water wadeable stream size starts at about third order, which dictates that most of the electrofishing will be done with a combination of backpack electrofishing unit(s) and towboat(s). Backpack crews will have a minimum of 3 members. The backpack unit should consist of two hand-held probes with electrodes mounted on fiberglass poles, one positive (anode) and one negative (cathode). Each probe should have a power cutoff switch. Trends have been toward the use of battery operated backpack units, but battery or electrical generating units may be used.

Channel width and depth should be considered before choosing between a backpack and a towboat electrofishing method. Towboat electrofishing units will have a portable generator, pulsator or power

box and two hand-held probes - anode poles and a trailing or hull- laden cathode. Electrofishing techniques with tow boats require an electrofishing crew consisting of four to six individuals. On the largest streams, using multiple electrofishing units and eight or possibly more crew members may be needed during the collection phase of the sampling.

Table 2. Possible combinations of gear and crew requirements.

Electrofishing Gear	Number of Crew
Backpack	Minimum 3
Towboat	4 to 6
One Towboat, 2 Passes	5 or more
Towboat & Backpack	7 or more
Two Towboats	8 or more

Electrofishing crews and supporting netters shall use collecting nets in good condition or repair and with at least 0.25” mesh size.

Streams in the wadeable classification will have considerable variation in stream width and, at times, this will make the selection of electrofishing gear and crew size complicated. Crew Leaders should be familiar with the sites and select the appropriate electrofishing gear and crew size. Crew Leaders should communicate with each other concerning their experiences with different surveying situations. The beginning and ending points of a site should be at a natural barrier (e.g. riffle). The electrofishing effort should be a one-pass electrofishing effort, providing that the crew can cover both banks and/or shorelines. If the crew cannot cover both banks and/or shorelines in one pass, then another pass on the other bank or shoreline will be necessary. The exact latitude and longitude of the downstream limit should be recorded for each site. The time for the electrofishing effort is recorded on the survey sheet. Begin electrofishing in an upstream direction using a side-to-side sweeping motion to cover all habitats. Electrofishing tactics should be directed by the Crew Leader. Fish are held in buckets or a large tub for identification and enumeration. The crew will attempt to collect as many fish as possible of all species. Because the collection methods are not consistently effective for young-of-the-year fish and because their inclusion may seasonally bias the results, fish less than 25mm in length will not be identified or included in the samples.

As with any fish sampling method, the proper scientific collector permits are required and must be obtained before commencement of any electrofishing activity.

Safety

Safety procedures must be followed at all times. A brief safety overview is as follows: The Crew Leader has primary responsibility for safety while electrofishing. Electrofishing units have a high voltage output and may deliver a dangerous electrical shock. The crew should avoid contact with the water, probes, and the tow-boat unless sufficiently insulated against electrical shock. All crew members should wear waders with non-slip soles and watertight rubber (or electrician’s) gloves that cover to the elbows. All crew members should wear polarized glasses to enhance their ability to see fish and enhance their ability to see bottom structures to avoid tripping and falling.

While this brief summary may be sufficient to remind all seasoned, experienced electrofishing crews to practice safe sampling techniques, not all crew members will have the same level of experience with varying gear and electrofishing scenarios as other crew members. Therefore, Crew Leaders must conduct frequent gear, equipment, and technique orientations. This is particularly critical with newer and seasonal staff. The Department has two general guidance documents for electrofishing activities, “Introduction to Basic Electrofishing Techniques” and “Policy for Electrofishing Personnel and Equipment Safety,” referenced in the Department’s Standardized Biological Field Collection and Laboratory Methods (PADEP “Methods”). Therefore, crews must review the PADEP electrofishing documents to assure that all safety concerns are presented and gaps in differing safety protocols are covered.

Field Sample Processing Procedures

Since semi-quantitative fish surveys depend on the collection of fish for species identification, temporary retention of a significant number of fish is required. In order to minimize stress and lethality to the greatest extent possible, the following field procedures will be followed:

- Removal of stunned fish from the electrical field as soon as possible.
- Netted fish will be transferred to containment devices as soon as possible. These fish containments will be a combination of:
 - Large buckets or barrels
 - Live wells constructed of framed netting that form a cage that is submerged in the stream
- Water is replaced regularly in warm weather to maintain adequate dissolved oxygen levels in the water, reduce waste by-products, and minimize mortality.
- Aeration will be provided to further minimize stress and mortality if necessary.
- Field identifications and releases will start as soon as possible.
- Every effort will be made to minimize holding and handling times.

Special handling procedures may be necessary for species of special concern. Fish that are not retained for vouchers or other purposes are released back into the water after they are identified to species and enumerated. Invasive alien species will be kept and appropriately disposed of out of the water if requested by state collecting permits. Each sample crew must have at least one person qualified as a taxonomic specialist in field fish identification. A recognized taxonomic expert that is part of the project will accompany field crews during at least 10 % of the sample collections. The majority of captured fish are identified to species in the field; however, any uncertainty about the field identification of individual fish requires their preservation for later laboratory identification, except for unusually large specimens that are photographed. Only that portion of the collected fish necessary for vouchering and laboratory ID confirmation will be retained. See Appendix A for guidance for selecting fish to be returned to the laboratory. Fish are preserved for future identification in buffered 10% formalin and labeled by date, time, river, and geographic identifiers (e.g. pool or river mile). Identification is required to the species level at a minimum and may be necessary to the subspecies level in certain instances. Vouchered fish will be identified by one of several recognized taxonomic experts. Fish will be transferred from 10% formalin to wash water and then to a series of ethyl alcohol washes from 35% to 50% to 70%. Voucher specimens will be deposited in a vertebrate collection in the PADEP Archived Sample Storage (1549 Bobali Drive; Harrisburg, PA). Specimens may also be retained for reference collections. A number of regional ichthyology keys will be used and include Lee et al (1980), Trautman (1981), Phillips et al (1982), Tomelleri and Eberle (1990), Smith (1979), Cooper (1983), Jenkins et al (1994), and Page et al (1991).

Field Chemistries

Field chemical data, including water temperature, pH, conductivity, dissolved oxygen, and alkalinity, should be collected in conjunction with fish surveys per the PADEP Surface Water Collection Protocol. The results of the field chemical test should be recorded on the field data sheet (Appendix B).

Habitat Field Forms

A physical habitat survey must be done in conjunction with all wadeable fish surveys. The PADEP Modified RBP Habitat Assessment Protocol for wadeable streams and rivers is based on the habitat assessment method found in the Rapid Bioassessment Protocols for Use in Wadeable Streams and Rivers Second Edition, July 1999 (Barbour, et al.). The PADEP Modified RBP Habitat Assessment form is located in Appendix B. The Crew Leader or a member of the crew should be trained in the visual-based habitat assessment technique needed to accurately complete the habitat assessment.

The reach length must be determined before the habitat assessment form is completed. The habitat assessment form may be completed before or after the fish sample is collected. However, the crew will have a better understanding of the habitat characteristics after the fish collection is completed. Most of the habitat parameters are evaluated within the limits of the sample reach, but frequency of riffles, grazing or disruptive pressures and riparian widths may be evaluated based on the area that can be observed from the reach, not just within the reach.

Field Data Recording

Field data and observations will be recorded on PADEP field data forms printed on water resistant paper. Fish assemblage data including species and quantity, chemical/physical data, site name, station number, number comprising sampling crew, time of day, total time sampled, distance sampled, electrofishing unit settings, and electrode configurations will be recorded on the fish sampling data sheet.

All field sampling activities will be under the direction of the Crew Leaders. The Crew Leader will maintain a field activities log noting all circumstances related to field sampling, site access, weather, and other relevant observations. Crew Leaders are responsible for adherence to sampling protocol. However, in the case of unforeseen circumstances, it is permissible for divergence from the field protocols and explanation must be provided on field forms. Each team shall have a taxonomic specialist responsible for directing and verifying field taxonomic identifications and supervising all quality assurance activities pertaining to vouchering specimens for their team's samples. Each sample crew must have at least one person qualified as a taxonomic specialist in field fish identification.

Voucher specimen samples will serve to validate new species distribution records and for verification of questionable field identifications and establish identifications of specimens that could not be identified in the field. Each set of vouchers is labeled with the same locational data recorded on the field forms with a notation on the field form indicating that voucher specimens were collected. All data will be placed into the PADEP Stream and Lake Information Management System (SLIMS) database.

Literature Cited

- Barbour, M.T., J. Gerritsen, B.D. Snyder, and J.B. Stribling. 1999. Rapid Bioassessment Protocols for Use in Streams and Wadeable Rivers: Periphyton, Benthic Macroinvertebrates and Fish, Second Edition. EPA 841-B-99-002. U.S. Environmental Protection Agency; Office of Water; Washington, D.C.
- Becker, G.C. 1983. Fishes of Wisconsin. University of Wisconsin Press, 1983 xii, 1052 p.
- Boschung, H.T. and R.L. Mayden. 2004. Fishes of Alabama. Smithsonian Institution, Washington, 736 p.
- Cooper, E.L. 1983. Fishes of Pennsylvania and the northeastern United States. Penn. State Univ. Press, University Park. 243 p.
- Department of Environmental Protection. 2013. Standardized Biological Field Collection and Laboratory Methods.
- _____. 2012. Surface Water Collection Protocol.
- Etnier, D.A. and W.C. Starnes. 1993. The Fishes of Tennessee. The University of Tennessee Press, Knoxville, 689 p.
- Jenkins, R. E. and N. M. Burkhead. 1994. Freshwater fishes of Virginia. Am. Fisheries Soc., Bethesda, MD. 1078pp.
- Lee, D. S., C. R. Gilbert, C. H. Hocutt, R. E. Jenkins, D. E. McAllister, and J. R. Stauffer, Jr. 1980. Atlas of North American Freshwater Fishes. North Carolina State Museum of Natural History. 867 pp.
- Page, L. M., and B. M. Burr. 1991. A field guide to freshwater fishes. Houghton Mifflin Co. Boston.
- Smith, C. L. 1985. The inland fishes of New York State. NY State Dept. of Conservation.
- Stauffer, J. R., Jr., J. M. Boltz, and L. R. White. 1995. The fishes of West Virginia. Proceedings of the Academy of Natural Sciences of Philadelphia 146: 1–389.
- Trautman, M. B. 1981. The Fishes of Ohio. 2nd Ed. Ohio State Univ. Press, Columbus, 782 p.
- Walsh, S.J., and M.R. Meador. 1998. Guidelines for quality assurance and quality control of fish taxonomic data collected as part of the National Water-Quality Assessment Program. U.S. Geological Survey Water-Resources Investigations, Report 98-4239, 33 p

**Appendix A (Wadeable Semi-Quantitative
Fish Sampling Protocol for Streams)**

**Pennsylvania Fish and Boat Commission
Division of Environmental Services**

**Rationale and Procedure for Vouchering Fish
Specimens**

Rationale and Procedure for Vouchering Fish Specimens

Rationale:

New survey methods and increased sampling efforts have enabled more complete survey coverage of habitats and watersheds and as a result, new fish occurrence records are being reported. Improved water quality within Pennsylvania's rivers and streams has also led to the recolonization of historic ranges and, in turn, opportunities for documentation by modern scientists. Records of significant occurrences (first PA collection, new drainage, range extension, rediscovery of extirpated species, etc.) may be subject to debate without the verification of identity afforded by voucher specimens. Misidentifications are hard to resolve without a specimen and tend to become a chronic problem. Collection of voucher specimens is warranted and reasonable when identification may result in unique records.

Preservation Procedure:

Fish should be preserved as soon as possible after collection. Fixation in 10% buffered formalin (100% formalin usually contains 37 – 40 % aqueous formaldehyde, see MSDS sheet) for two to four weeks (+/- depending on specimen size) and then storage in alcohol is recommended. To mix 10% formalin, a ratio of one part 100% formalin should be mixed with nine parts water (9:1), resulting in a ~ 3.7 - 4 % aqueous formaldehyde solution. Mix formalin solutions from a full strength source as needed to minimize consumption. Pre-mixed 10% formalin can also be purchased from sources like Fisher Scientific or VWR. Be aware that specimens introduce additional water to a container and the formalin mixture may need to be increased for proper fixation if a large collection is to be preserved. Large specimens (> 20 cm) may require formalin to be injected or a small shallow incision of 2 - 3 cm about the abdominal cavity to promote even fixation. Avoid crowding or bending of specimens within formalin jugs, so that fixation occurs easily and the physical integrity of specimens is retained. Avoid exposing formalin to cold temperatures. If white precipitate (trioxymethylene) has formed, dispose of the formalin. Over time, formalin solutions tend to become acidic from oxidation and produce methanol. During fixation, methanol promotes clumping of proteins instead of cross-linking. Do not leave specimens in formalin for long periods. Mixed formalin (~10%) should be discarded after about a season of use. Preservation solely in alcohol is not desirable since fixation does not occur and specimen integrity becomes diminished.

After the fixation period, fish should be removed from formalin and the washing process should begin. Reuse or properly discard the formalin. There are two methods that can be used for washing, the traditional water washes or a stepwise increase in alcohol concentration. For water washes, specimens are moved to a bucket or container of water for about a week to draw formalin from the tissues. Total soak time is dependent on the size and number of specimens and can be adjusted based on residual formalin odor. Wash water should be replaced daily or twice daily. After the specimens are washed, they should be moved to 45 - 50% isopropyl alcohol or 70% undenatured ethyl alcohol for long term storage. Denatured ethanol can contain numerous contaminants that compromise long term storage of biological specimens. Ethanol is a superior storage medium when available. Measure and mix alcohol in the laboratory under normal temperatures (~20°C), since concentrations will be influenced by temperature. Current museum practices call for specimens to be soaked in increasing concentrations of

alcohol to reduce osmotic pressures within specimen tissues. If using ethanol, the washes would be 20%, 40%, 60%, and then 70%. In most cases, field biologists use the traditional water washing method due to its simplicity, but the gradual increase of concentrations is superior. Deionized water should be used to dilute alcohol if specimens are to be deposited in a museum for indefinite storage.

Plastic containers are typically used for formalin and glass/flint jars are typically used for long term storage in alcohol. Either type of container is acceptable, but the fluid type should be clearly labeled on the container for safety reasons. A formalin resistant tag, written in pencil or waterproof pen, should contain as much of the following information as possible:

- 1) Detailed Locality information (River Mile)
- 2) Genus/species and common name
- 3) Number captured
- 4) Collectors
- 5) IDed by
- 6) Date
- 7) Latitude and Longitude
- 8) Habitat, Depth, H₂O Conditions, H₂O Chemistries
- 9) Gear Used
- 10) Any other relevant information or comments

Once a specimen is stored, the primary causes of deterioration are often associated with alcohol or container quality. Check your jar lids before reusing them and periodically check the alcohol levels for evaporation. If significant alcohol has evaporated, dispose of the remaining alcohol and replace it with the proper concentration of the same type. The type can be determined by smell. If one must replace one alcohol type with another, specimen damage may occur. This may be minimized by a stepwise increase in concentration of the new alcohol type. Sunlight (UV) will bleach specimens and heat accelerates alcohol evaporation, so store jars in a cool UV protected place.

Keep in mind that formalin is a carcinogen and alcohol is flammable. Both can be skin irritants. Wear protective eye and hand wear. Work in well ventilated areas. Know where your MSDS sheets, lab first aid kits, and eye wash stations are located. Be prepared to communicate dangers with staff, clean up spills, and perform relevant first aid.

Digital Images:

Digital images are also beneficial if relatively high-resolution equipment is available. Digital images may be a good method of vouchering an occurrence if diagnostic characters are easily distinguished and specimens are not necessary. Digital images should show relevant characteristics (mouth position, diagnostic pigmentations, lateral line, squamation, spine/ray counts, gill rakers, etc.). One of the pictures should be of the left side of the whole fish.

**Appendix B ((Wadeable Semi-Quantitative
Fish Sampling Protocol for Streams)**

**FIELD DATA SHEET SEMI QUANTITATIVE
FISH SURVEY SAMPLING**