

# Wastewater Treatment Plant Operator Certification Training



## Module 17: The Activated Sludge Process Part III

Revised October 2014

This course includes content developed by the Pennsylvania Department of Environmental Protection (Pa. DEP) in cooperation with the following contractors, subcontractors, or grantees:

The Pennsylvania State Association of Township Supervisors (PSATS)  
Gannett Fleming, Inc.  
Dering Consulting Group  
Penn State Harrisburg Environmental Training Center



### Topical Outline

#### Unit 1 – Modifications of the Conventional Activated Sludge Process

- I. Review of the Conventional Activated Sludge Process
  - A. Process Description
  - B. Key Process Design Parameters
  - C. System Configuration
  
- II. Reasons for Modifying the Conventional Activated Sludge Process
  - A. Operational Benefits
  - B. Site Characteristics
  - C. Economic and Labor Benefits
  
- III. Common Modifications of the Activated Sludge Process
  - A. Contact Stabilization
  - B. Kraus Process
  - C. Step-Feed Aeration
  - D. Complete Mix
  - E. Extended Aeration (Oxidation Ditch)
  - F. Biological Nutrient Removal Processes: Bardenpho, Anaerobic/Anoxic/Oxidation (A<sup>2</sup>/O), Modified Ludzack-Ettinger (MLE)
  - G. Summary: Permissible Aeration Tank Capacities and Loadings

#### Unit 2 – The Sequencing Batch Reactor (SBR)

- I. Description of the SBR Processes
  - A. Basic Operating Principles of SBR
  - B. Key Differences Between SBRs and Continuous Activated Sludge
  
- II. Configuration of the SBR System
  - A. Preliminary Treatment
  - B. Reactor Components
  - C. Sequencing Control
  - D. Ancillary Treatment

## **MODULE 17: THE ACTIVATED SLUDGE PROCESS, PART III**

---

- III. Operation of SBRs
  - A. Stages of Operation
  - B. Operating Guidelines
  - C. Process Control Considerations

Appendix – Sustainable Infrastructure Wastewater Operations Informational Sheet; *“Sequential Batch Reactors (SBR)” Activated Sludge*

---

---

# Unit 1 – Modifications of the Conventional Activated Sludge Process

---

---

## Learning Objectives

- Explain why it may be necessary to modify the conventional activated sludge process.
- List and explain other common modifications of operating the activated sludge process.

### Process Description

The following elements describe the conventional activated sludge process:

- Both influent or primary clarifier effluent and return sludge are introduced at the head of the aeration tank, which creates the greatest oxygen demand at that point.
- Oxygen demand decreases uniformly from the inlet to the outlet of the aeration tank.

The conventional activated sludge process is susceptible to failure from shock loads.



**Shock Load** is wastewater with elevated concentrations of contaminants that arrives at the treatment plant for a brief period of time.



**Mixed Liquor Suspended Solids (MLSS)**, also known as mixed liquor, consists of a mixture of the influent or primary clarifier effluent and the return sludge, which contains the microorganisms needed to maintain the treatment process.



Because of its relatively low mixed liquor suspended solids (MLSS) concentration and its head-end loading, the conventional activated sludge process is most suitable for low-strength, domestic wastes with minimal peak load considerations.

### Key Process Design Parameters

The following range of process design parameters is permissible for a conventional activated sludge process:

F/M Ratio*	0.2 - 0.5 #BOD / #MLVSS / day
Organic Loading (maximum)	40 #BOD / 1,000 cubic feet / day
MLSS	1000 – 3000 mg / liter
Aeration Retention Time (minimum)**	6 hours
Solids Recycle Rate**	15% – 100%

\*F/M = food to microorganism ratio

#BOD = pounds of Biochemical Oxygen Demand (BOD)

#MLVSS = pounds of Mixed Liquor Volatile Suspended Solids

\*\*Based on maximum monthly average influent flow rate



**Biochemical Oxygen Demand (BOD)** is the rate at which organisms use the oxygen in water or wastewater while stabilizing decomposable organic matter under aerobic conditions. In decomposition, organic matter serves as food for the bacteria and energy results from its oxidation. BOD measurements are used as a measure of the organic strength of wastes in water.<sup>1</sup>



**Mixed Liquor Volatile Suspended Solids (MLVSS)** is the organic or volatile suspended solids in the mixed liquor of an aeration tank. This volatile portion is used as a measure of the amount of microorganisms' present.<sup>2</sup>

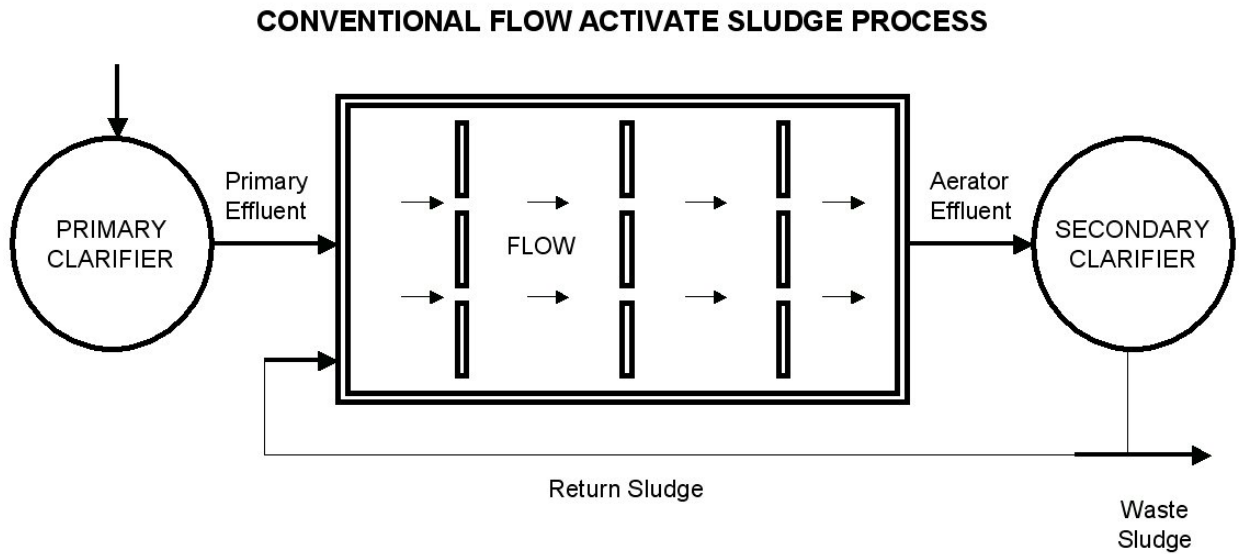
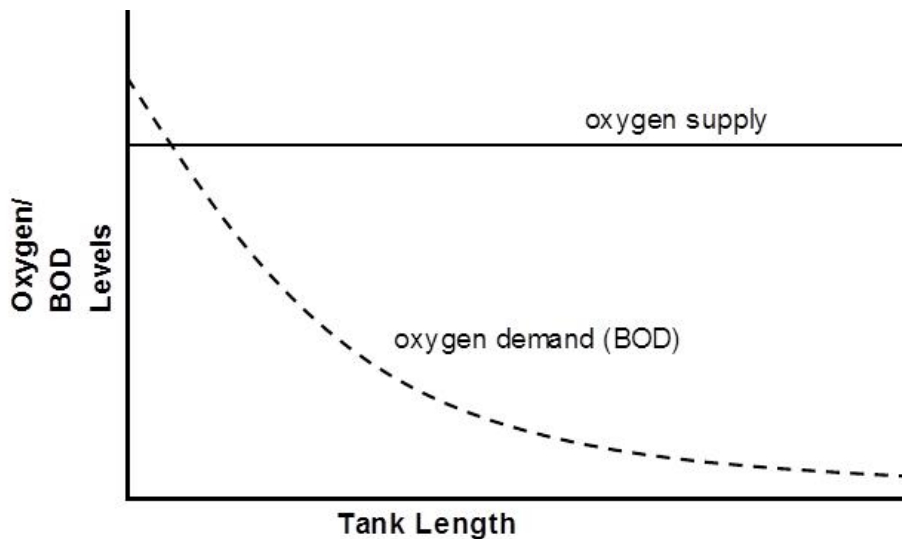

Figure 1.1 Schematic Drawing of a Conventional Activated Sludge System

- The conventional activated sludge process uses a plug-flow reactor that is generally long and relatively narrow.
- Aeration capacity is uniform along the length of the tank and is designed to minimize back-mixing.
  - Commingling of mixed liquor upstream or downstream in any part of the reactor is minimized.
- Mixed liquor is removed at the end of the aeration tank and transferred to the secondary clarifier.



**Oxygen Supply vs. Oxygen Demand for Conventional Aeration**



---

## **REASONS FOR MODIFYING THE CONVENTIONAL ACTIVATED SLUDGE PROCESS**

---

### **Operational Benefits**

Modifications to the process can be made in an existing system or in the design process of a new system. Potential operational benefits of modifying the conventional activated sludge system include:

- Increasing organic loading.
- Providing additional nutrients required for proper treatment.
- Accommodating flow rate or organic loading that varies seasonally.
- Achieving nutrient removal.

### **Site Characteristics**

Another common reason for modification of the process is to provide a treatment system that is suitable to the available site conditions. For example, extended aeration systems, especially oxidation ditch configurations, require more space than conventional systems. Alternately, where space is limited, a pure oxygen system or a complete mix configuration would be more suitable.

These systems, along with others, will be discussed in more detail throughout the chapter.

### **Economic and Labor Benefits**

The energy and labor requirements of each system are determinants in choosing the best modification. A smaller municipality may not be able to sustain some of the more labor and energy intensive systems. For example, oxidation ditches are usually low energy, low labor systems. Pure oxygen systems, however, require greater amounts of energy and labor.

### Contact Stabilization

#### Process Description

Contact Stabilization presumes that organic matter (BOD) destruction is a two-step process in which:

- BOD is first adsorbed by the microorganisms.
- BOD is then metabolized by the microorganisms for energy and growth.



**Adsorption** refers to the process in which the colloidal and particulate organic content of the wastewater becomes attached to the microorganisms.

Based upon that presumption, the contact stabilization process requires two aeration tanks: a contact tank and a stabilization tank.

A **Contact Tank** is used for aeration of the mixed liquor.

- Influent or primary clarifier effluent is added to the contact tank.
- While in the contact tank, colloidal and particulate organic matter (BOD) is adsorbed onto the microorganisms.
- Residence time in the contact tank is approximately 30 to 90 minutes.
- After leaving the contact tank, the mixed liquor is settled in the secondary clarifier and the MLSS containing the biomass is returned to the stabilization tank.
- The treatment cycle then restarts.

A **Stabilization Tank** is used to reaerate return sludge prior to mixing it with the primary effluent.

- While in the stabilization tank, most of the organic material that was adsorbed by the microorganisms in the contact tank is metabolized.
- Residence time in the stabilization tank is approximately 4 to 6 hours.

---

## COMMON MODIFICATIONS OF THE ACTIVATED SLUDGE SYSTEM

---

### Key Process Design Parameters

The following range of process design parameters is permissible for a Contact Stabilization activated sludge process:

F/M Ratio*	0.2 - 0.6 #BOD/#MLVSS/day
Organic Loading (maximum)	60 #BOD/1,000 cubic feet/day
MLSS	1000 – 3000 mg/liter
Aeration Retention Time (minimum)**†	5 hours
Solids Recycle Rate**	50% – 150%

\*F/M = food to microorganism ratio

#BOD = pounds of Biochemical Oxygen Demand (BOD)

#MLVSS = pounds of Mixed Liquor Volatile Suspended Solids

\*\*Based on maximum monthly average influent flow rate

† based on total aeration capacity in contact and stabilization tanks. (The stabilization tank is typically 30-35% of the capacity of the contact tank)

### System Configuration

To modify the conventional activated sludge system into a contact stabilization system, the following changes are made:

- Primary effluent is introduced into the Contact Zone.
- A stabilization tank is added to stabilize the adsorbed organics.
- Overall oxygen demand is split between contact tank and stabilization tank.
- A benefit of this process modification is the ability to perform well under high flow, wet weather conditions.

## COMMON MODIFICATIONS OF THE ACTIVATED SLUDGE SYSTEM

---

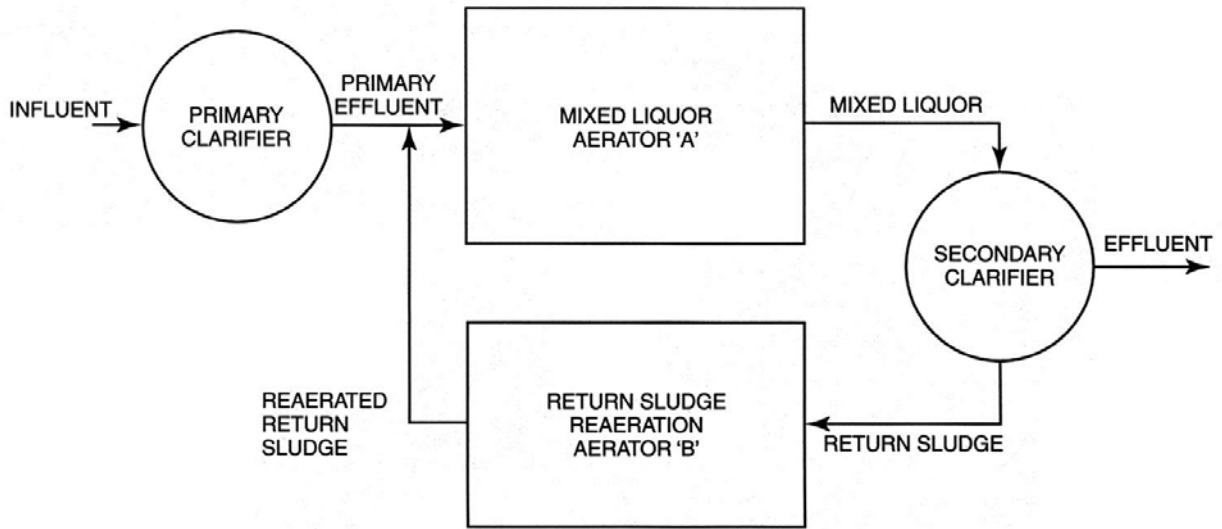

Figure 1.2 Schematic Drawing of a Contact Stabilization System<sup>3</sup>

## Kraus Process

### Process Description

Kraus Process is used to treat wastewater that is deficient in nitrogen. It is also used when activated sludge has poor settling characteristics. This modification is most applicable for treatment facilities receiving wastewater that is high in carbohydrates.

The process uses a reaeration tank that is similar to the contact stabilization process, with some important modifications:

- Not all of the return sludge is reaerated; some is returned without being retreated.
- Digester supernatant and digester sludge is also added to the reaeration tank.
- Retention time in the reaeration tank is approximately 24 hours.

Ammonia nitrogen in the digester sludge and supernatant is converted to nitrate nitrogen in the reaeration tank. Effluent from the reaeration tank is mixed with the return sludge to correct the nitrogen deficiency in the influent wastewater. Also, the concentration of inert solids from the digester, when mixed with the mixed liquor, improves the settleability of the mixed liquor.

### Key Process Design Parameters

The following range of process design parameters is permissible for a Kraus activated sludge process.†

F/M Ratio*	0.3 - 0.8 #BOD/#MLVSS/day
Organic Loading (maximum)	70 #BOD/1,000 cubic feet/day
MLSS	1000 – 2500 mg/liter
Aeration Retention Time (minimum)	4 hours
Solids Recycle Rate**	15% – 100%

† Does not consider the reaeration tank

\*F/M = food to microorganism ratio

#BOD = pounds of Biochemical Oxygen Demand (BOD)

#MLVSS = pounds of Mixed Liquor Volatile Suspended Solids

\*\*Based on maximum monthly average influent flow rate

### System Configuration

To modify the conventional activated sludge system into a Kraus process system, the following changes are made:

- The reaeration tank is added.
- Recycling and reaeration of the digester supernatant and solids occurs.
- A portion of the return sludge is reaerated.

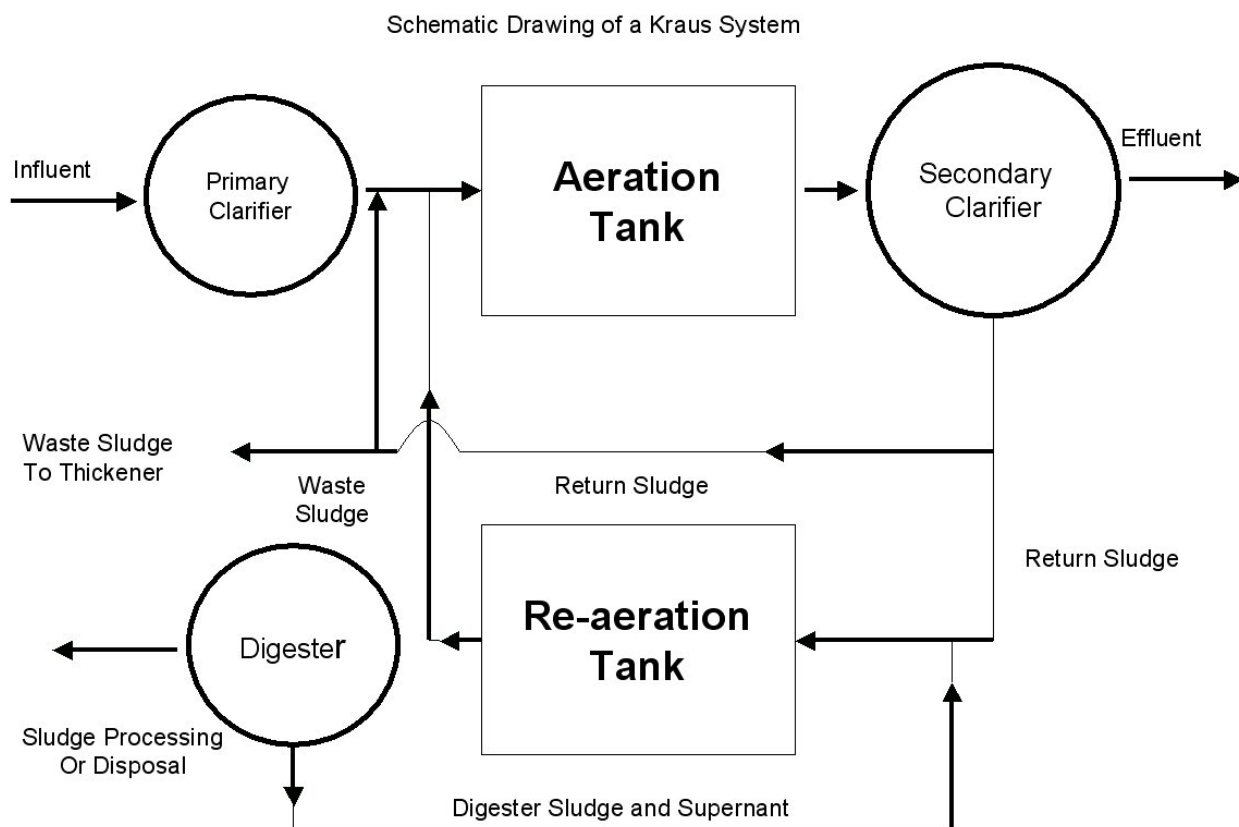

Figure 1.3 Schematic Drawing of a Kraus System

## Step-Feed Aeration

### Process Description

This process modification is used to provide a more uniform distribution of oxygen demand throughout the aeration tank. It is particularly beneficial when dealing with variable **shock loads**.

- Primary effluent is piped to two or more locations along the length of the aeration tank.
- Distributed loading minimizes any decreases in dissolved oxygen concentration along the length of the aeration tank.
- The percent of primary effluent distributed to each location can be varied to optimize process performance.

### Key Process Design Parameters

The following range of process design parameters is permissible for a step feed activated sludge process:

F/M Ratio*	0.2 - 0.5 #BOD/#MLVSS/day
Organic Loading (maximum)	40 #BOD/1,000 cubic feet/day
MLSS	1000 – 3000 mg/liter
Aeration Retention Time (minimum)	6 hours
Solids Recycle Rate**	15% – 100%

\*F/M = food to microorganism ratio

#BOD = pounds of Biochemical Oxygen Demand (BOD)

#MLVSS = pounds of Mixed Liquor Volatile Suspended Solids

\*\*Based on maximum monthly average influent flow rate

### System Configuration

To modify the conventional activated sludge system into a step-feed aeration system, the following changes are made:

- Primary effluent is distributed to multiple locations in the aeration tank.
- Baffling of the aeration tank creates multiple mixing zones coincident with the distribution points.
- Operational flexibility is achieved by varying the amount of primary effluent distributed to each area.

# COMMON MODIFICATIONS OF THE ACTIVATED SLUDGE SYSTEM

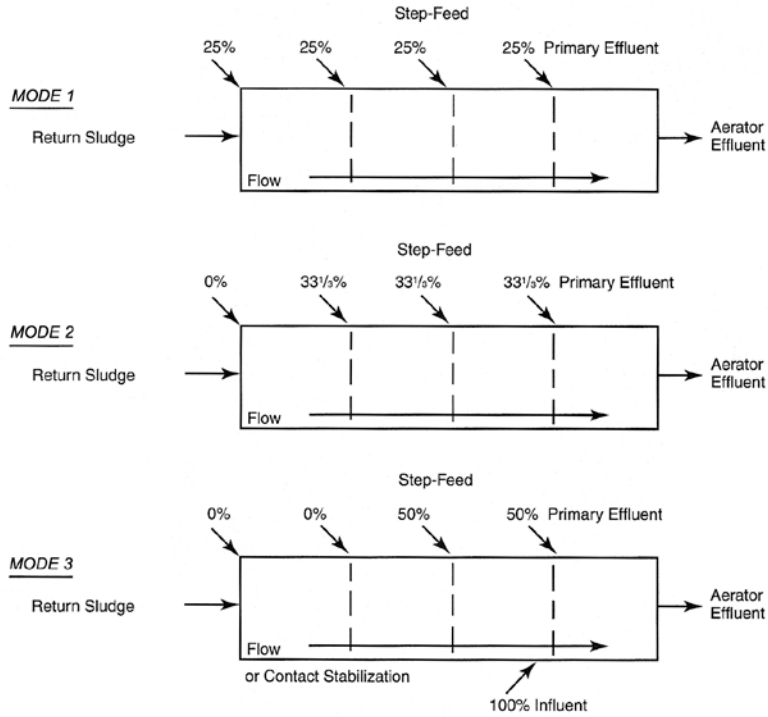

Several possible modes of feeding primary effluent to the aeration tanks. Some tanks may have more or fewer points of discharge into the tank

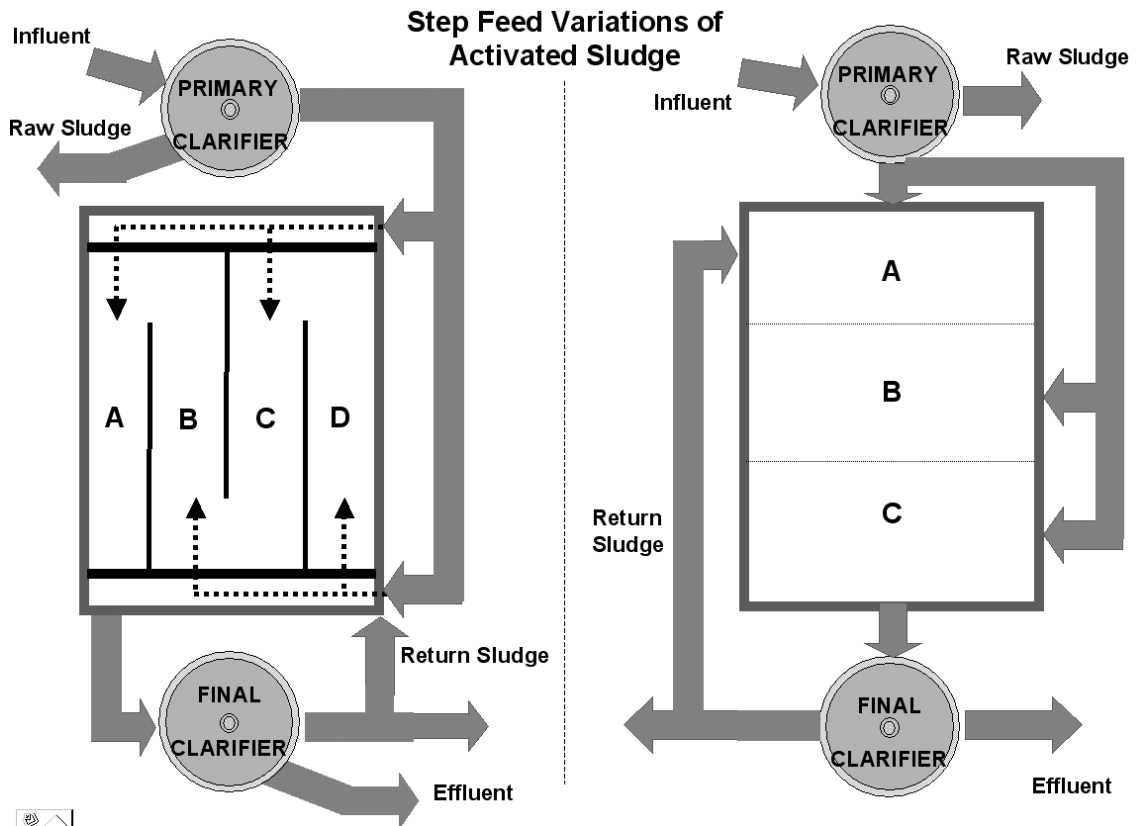



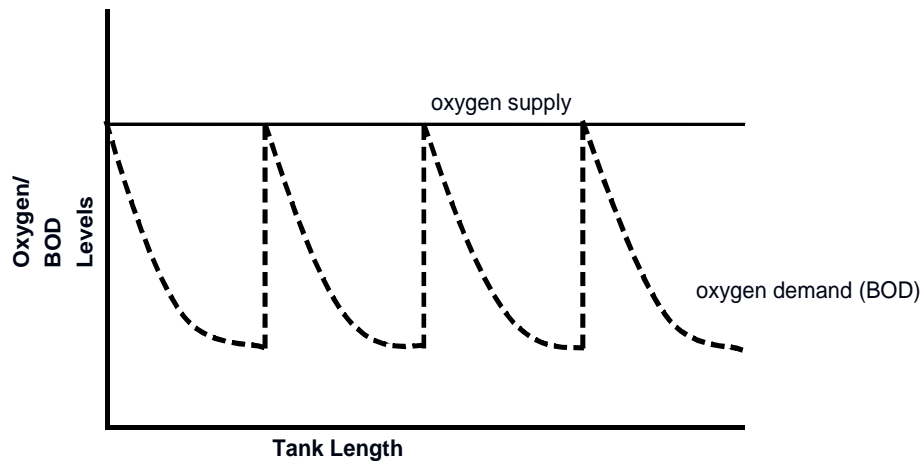

**Oxygen Supply versus Oxygen Demand for Step Aeration**

### Complete Mix

#### Process Description

This modification is used to simulate a completely-mixed reactor tank in which conditions within the tank are the same throughout the tank. The benefits of this modification include greater volumetric loading, a more stable microbial population, more efficient aeration, and tolerance of shock loads.

- Both primary effluent and return sludge are distributed uniformly along the length of the aeration tank.
- Mixed liquor is removed uniformly from the length of the aeration tank.
- Aerators are located uniformly along the aeration tank.

#### Key Process Design Parameters

The following range of process design parameters is permissible for a complete mix activated sludge process:

F/M Ratio*	0.2 - 0.5 #BOD/#MLVSS/day
Organic Loading (maximum)	40 #BOD/1,000 cubic feet/day
MLSS	1000 – 3000 mg/liter
Aeration Retention Time (minimum)	6 hours
Solids Recycle Rate**	15% – 100%

## COMMON MODIFICATIONS OF THE ACTIVATED SLUDGE SYSTEM

\*F/M = food to microorganism ratio

#BOD = pounds of Biochemical Oxygen Demand (BOD)

#MLVSS = pounds of Mixed Liquor Volatile Suspended Solids

\*\*Based on maximum monthly average influent flow rate

### System Configuration

To modify the conventional activated sludge system into a complete mix system, the following changes are made:

- Primary effluent is distributed to multiple locations throughout the aeration tank.
- The flexibility of operation is enhanced by varying the amount of primary effluent distributed to each location.
- Baffling of the aeration tank creates multiple mixing zones coincident with the distribution points.

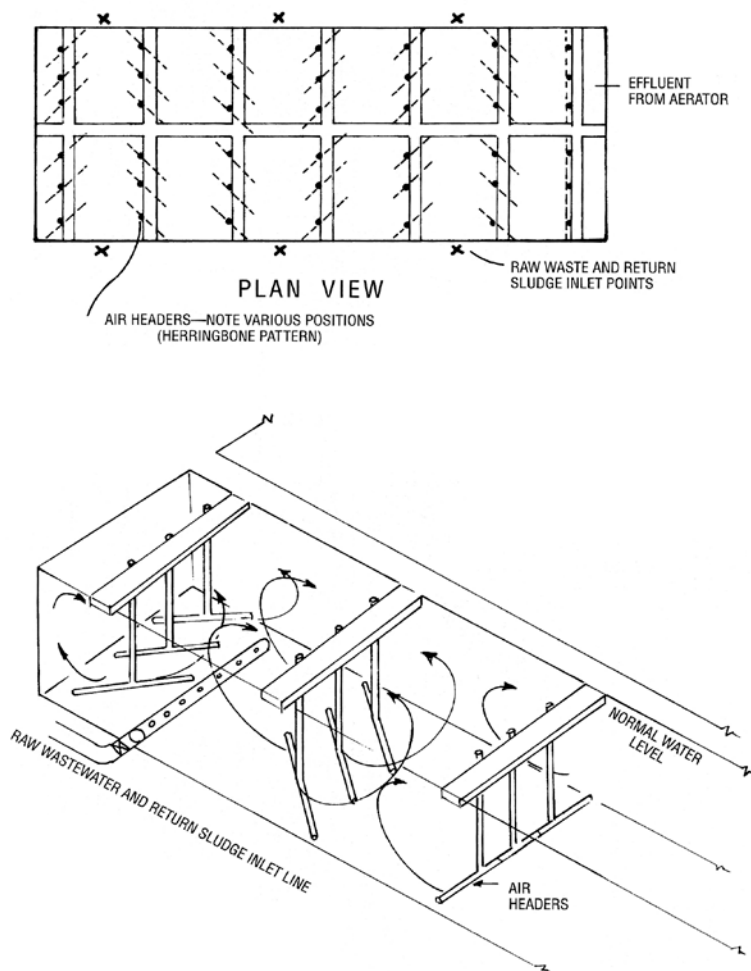
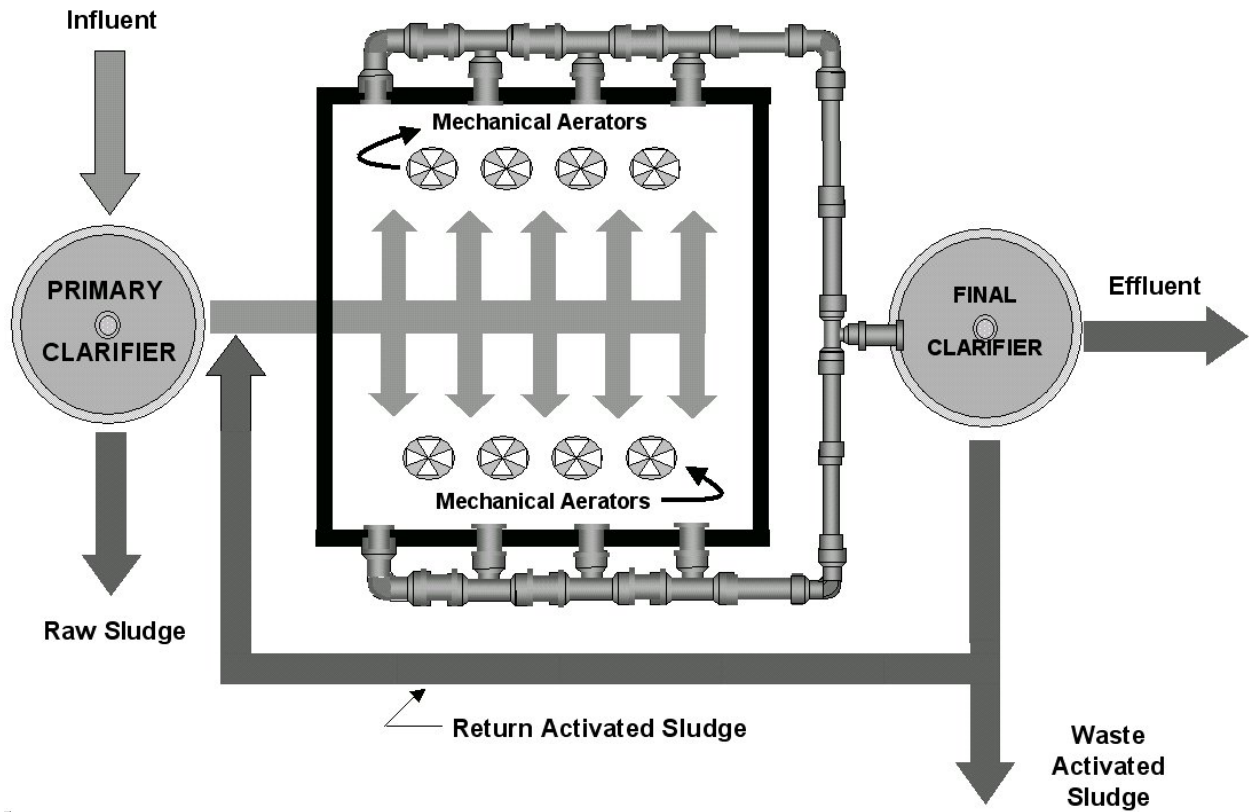
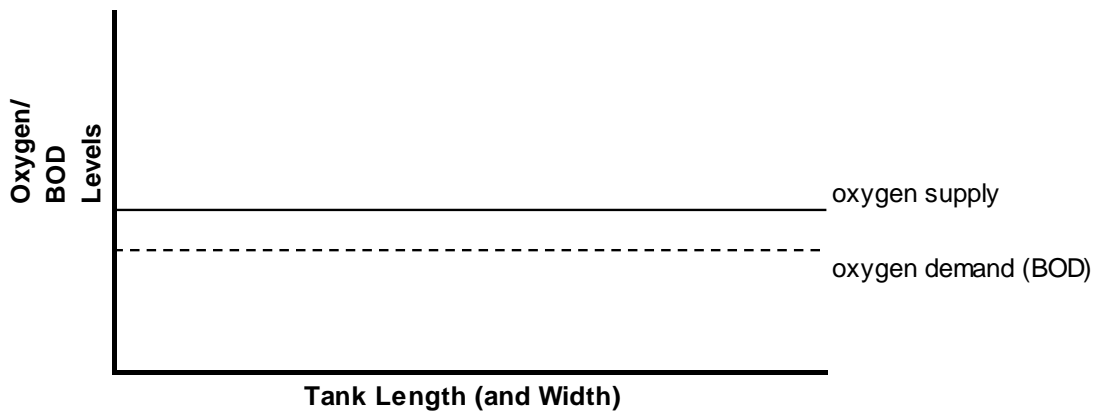

Figure 1.5 Schematic Drawings of a Completely-Mixed Aeration System<sup>5</sup>

**COMPLETE MIX ACTIVATED SLUDGE**



Schematic Drawing of a Completely-Mixed Aeration System



**Oxygen Supply vs. Oxygen Demand for Complete Mix Aeration**

### Extended Aeration (Oxidation Ditch)

#### Process Description

Extended aeration is often used for small treatment facilities requiring a simple process, in the form of a package treatment plant. It is also used for larger treatment plants in the form of oxidation ditches. Principal benefits of extended aeration modifications include reduced sludge handling and lower power requirements.

(NOTE: an overview of package plants and oxidation ditches is available in Module 4 of the DEP Wastewater Treatment Plant Operator Training.)

- A long aeration time (hydraulic loading) and low organic loading characterize this process.
- Primary clarification is often eliminated.
- Dissolved oxygen (DO) is introduced at intermittently spaced aerators and the DO concentration may be allowed to decrease significantly between aerators.
- The ditch configuration and the mixing energy applied are designed to maintain a velocity of approximately one foot per second, in order to keep solids in suspension.

#### Key Process Design Parameters

The following range of process design parameters is permissible for an extended aeration and oxidation ditch activated sludge processes:

F/M Ratio*	0.05 - 0.1 #BOD/#MLVSS/day
Organic Loading (maximum)	15 #BOD/1,000 cubic feet/day
MLSS	3000 – 5000 mg/liter
Aeration Retention Time (minimum)	24 hours
Solids Recycle Rate**	50% – 150%

\*F/M = food to microorganism ratio

#BOD = pounds of Biochemical Oxygen Demand (BOD)

#MLVSS = pounds of Mixed Liquor Volatile Suspended Solids

\*\*Based on maximum monthly average influent flow rate

# COMMON MODIFICATIONS OF THE ACTIVATED SLUDGE SYSTEM

## System Configuration

In this example of extended aeration, an oxidation ditch configuration is presented as a representative of the extended aeration modification. Many other configurations are possible. The principal differences between an oxidation ditch and a conventional activated sludge system are:

- An oxidation ditch is configured as a ring with continuous flow around the ring, which is induced by aerators.
- A clarifier may be located within the annular space of the ditch to save on construction costs and the amount of land required.
- Oxidation ditch rings may be interconnected at the ends in order to produce a long, continuous loop.

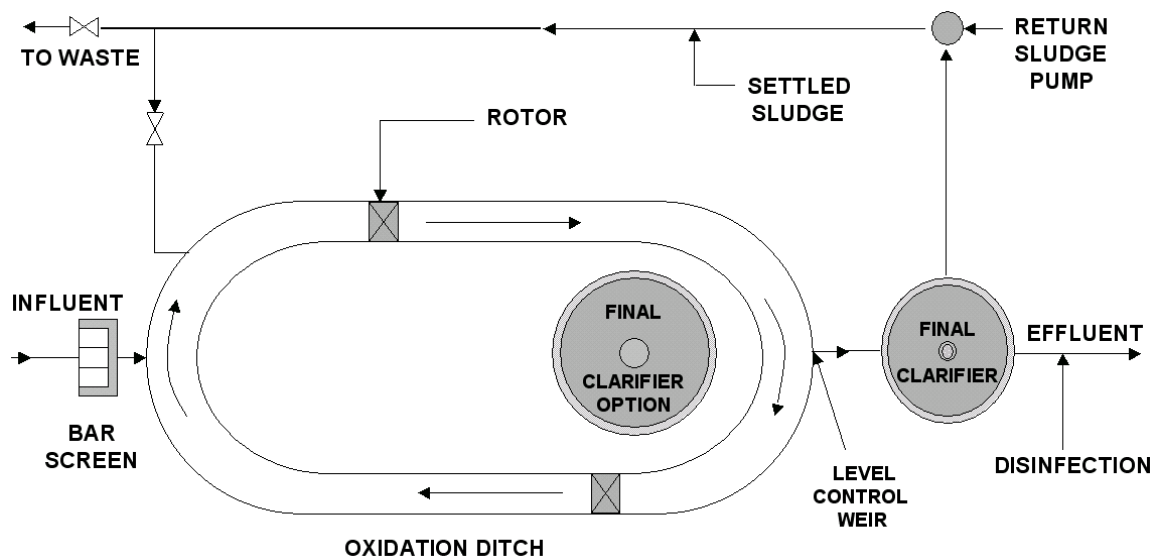
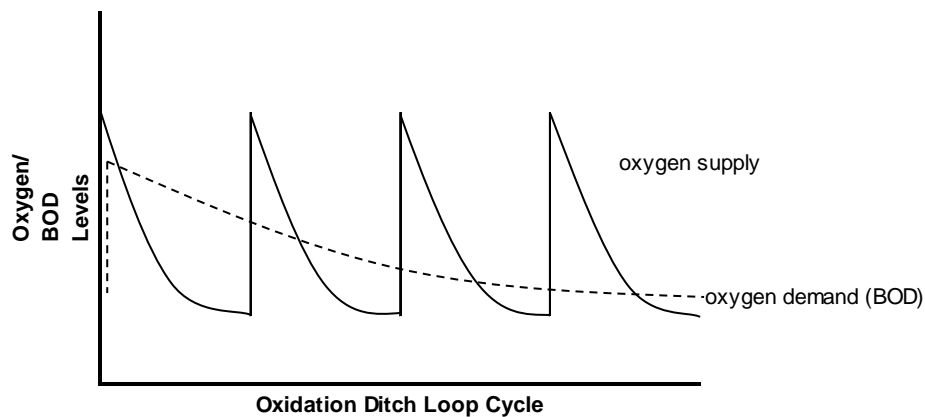

Figure 1.6 Schematic Drawing of an Oxidation Ditch



Oxygen Supply versus Oxygen Demand for Oxidation Ditch

### Biological Nutrient Removal Processes: Bardenpho, Anaerobic/Anoxic/Oxidation (A<sup>2</sup>/O), Modified Ludzack-Ettinger (MLE)

#### Process Description

These process modifications to the conventional activated sludge system are made to enhance the removal of nutrients from wastewater. A simple Bardenpho process is presented here to represent the range of Biological Nutrient Removal Processes.

(NOTE: An overview of Biological Nutrient Removal processes is available in Module 8, Overview of Advanced Wastewater Treatment, of the DEP Wastewater Treatment Plant Operator Training.)

- Ammonia nitrogen, which is present in raw municipal wastewater, is converted to nitrate nitrogen during normal activated sludge treatment.
- Anoxic (containing no residual dissolved oxygen) tanks or zones are added to the conventional activated sludge process train to convert the nitrates to nitrogen gas.
- In the anoxic zones, facultative bacteria strip oxygen from the nitrates since oxygen is not available in dissolved form in the wastewater.

#### Key Process Design Parameters (Typical Design)

The successful operation of a biological nutrient removal (BNR) system is dependent upon several process parameters, including:

- Temperature, which affects microbial reaction rates.
- pH and alkalinity, which must be controlled to prevent inhibition of microbial reactions.
- Dissolved oxygen concentration, which affects reaction rates and creates inhibitions.
- Mixing, this ensures uniform reactor conditions.
- Return of activated sludge and internal nitrate recycling, which provides necessary microorganisms and nitrate for the denitrification process in the anoxic zones.

---

## COMMON MODIFICATIONS OF THE ACTIVATED SLUDGE SYSTEM

---

The following range of process design parameters is permissible for the aeration tank in a Bardenpho activated sludge process:

F/M Ratio*	0.08 - 0.16 #BOD/#MLVSS/day
Organic Loading (maximum)	20 #BOD/1,000 cubic feet/day
MLSS	2000 – 5000 mg/liter
Aeration Retention Time (minimum)	12 hours
Clarifier Solids Recycle Rate**	15% – 100%
Aeration Tank MLSS Recycle Rate**	400%

\*F/M = food to microorganism ratio

#BOD = pounds of Biochemical Oxygen Demand (BOD)

#MLVSS = pounds of Mixed Liquor Volatile Suspended Solids

\*\*Based on maximum monthly average influent flow rate

### System Configuration

A simple four-tank Bardenpho process may be configured as follows:

- Influent wastewater, return sludge from the clarifier, and nitrified mixed liquor from the effluent end of the first aeration zone are introduced into the first anoxic tank.
- Effluent from the first anoxic tank discharges to an aerobic tank where nitrification occurs.
- Effluent from the nitrifying tank discharges to a second anoxic tank where denitrification occurs.
  - Nitrate-nitrogen is converted to nitrogen gas.
- Effluent from the denitrification tank discharges to a second aerobic tank.
  - Second tank raises DO level of the wastewater before clarification process begins.
- To obtain phosphorus removal, as well as nitrogen removal, an anaerobic tank is typically added to the front of the treatment train.

Several other configurations have been used to achieve biological nutrient removal.

- The MLE (Modified Ludzak Ettinger) process uses only the first two tanks in the four-stage Bardenpho process: the anoxic tank followed by the aeration tank. Both clarifier solids and aeration tank MLSS are returned to the anoxic tank.
- The A<sup>2</sup>/O (anaerobic, anoxic and aerobic, or oxic) process adds an anaerobic tank to the head of the MLE process and returns clarifier solids to this tank rather than the anoxic tank. The A<sup>2</sup>/O process will provide phosphorus as well as nitrogen removal.

## COMMON MODIFICATIONS OF THE ACTIVATED SLUDGE SYSTEM

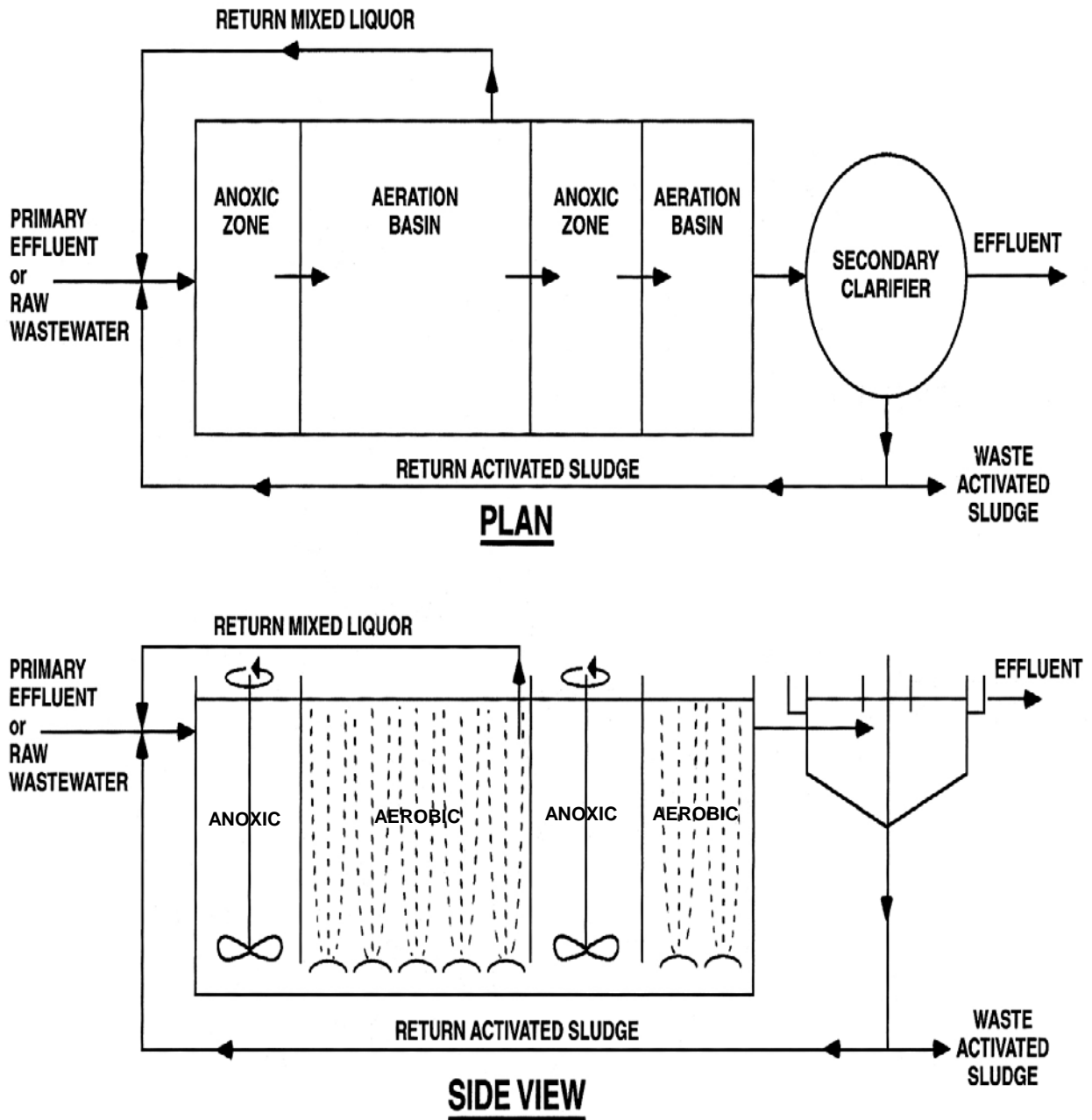

Figure 1.7 Schematic Drawing of the Representative Bardenpho System<sup>9</sup>



## COMMON MODIFICATIONS OF THE ACTIVATED SLUDGE SYSTEM

### Permissible Aeration Tank Capacities and Loadings<sup>7</sup>

Process	Mode of Aeration	Minimum Aeration Retention Time—Hours (based on maximum monthly average flow)	Maximum Aeration Tank Organic Loading <sup>*****</sup> Lb. BOD/1000 cu. ft./day	F/M Ratio lb. BOD/lb. MLVSS/day	MLSS mg/liter
Step Aeration, Complete Mix, and Conventional Activated Sludge	Air System	6	40	0.2 – 0.5	1000 – 3000
	Pure Oxygen System	2	160	0.3 – 1.0	3000 – 5000
Contact Stabilization	Air System	5*	60	0.2 – 0.6	1000 – 3000
Combined Carbon Oxidation-Nitrification	Air System	12	20	.08 - .16	2000 -5000
	Pure Oxygen System	4	60	.10 - .20	3000 – 5000
Extended Aeration and Oxidation Ditches	Air System	24	15	.05 – 0.1	3000 – 5000
Carbonaceous Stage of Separate Stage Nitrification	Air System	4	70	0.3 – 0.8	1000 – 2500
	Pure Oxygen System	1.5	250	0.5 – 1.0	3000 – 5000
Nitrification Stage of Separate Stage Nitrification	Air System	6	10 <sup>***</sup>	.05 - .20 <sup>****</sup>	1000 – 3000
	Pure Oxygen System	2	25 <sup>***</sup>	.08 - .20 <sup>****</sup>	3000 - 5000

\* Total aeration capacity includes both aeration and reaeration capacities. Normally the contact zone equals 30-35% of the total aeration capacity.

\*\* Not recommended if wastewater temperatures are expected to fall below 10° C.

\*\*\* Lb. NH<sub>3</sub>-N/1000 cu. ft./day

\*\*\*\* Lb. NH<sub>3</sub>-N/lb. MLVSS/day

\*\*\*\*\* Based on maximum daily BOD load to aeration tank.



### Key Points for Unit 1 - Modifications of the Conventional Activated Sludge Process

- Because of its relatively low mixed liquor suspended solids (MLSS) concentration and its head-end loading, the conventional activated sludge process is most suitable for low-strength, domestic wastes with minimal peak load considerations.
- Typical key process design parameters for an activated sludge process include: F/M ratio, organic loading (max), MLSS, aeration retention time (minimum) and solids recycle rate.
- Oxidation ditch systems require more space than conventional systems but are usually low energy and low labor systems.
- The conventional activated sludge process uses a plug-flow reactor that is generally long and relatively narrow.
- Oxidation ditch systems require more space than conventional systems but are usually low energy and low labor systems.
- The contact stabilization process requires two aeration tanks, a contact tank and a stabilization tank.
- The Kraus Process is often used to treat wastewater that is nitrogen deficient or has poor settling characteristics.
- A step-feed aeration system is beneficial when dealing with variable shock loads.
- A complete mix process can result in greater volumetric/hydraulic loading capacity.
- Influent with low organic loading may be a good candidate for extended aeration in package treatment plant or oxidation ditch treatment processes.

**Exercise for Unit 1 - Modifications of the Conventional Activated Sludge Process**

1. BOD measurements are used as a measure of the \_\_\_\_\_ strength of wastes in water.
2. The conventional activated sludge process uses a \_\_\_\_\_ - \_\_\_\_\_ reactor that is generally long and relatively narrow.
3. Potential benefits of modifying the conventional activated sludge system include:
  - a. Increasing organic loading.
  - b. Providing additional nutrients required for proper treatment.
  - c. Accommodating flow rate or organic loading that varies seasonally.
  - d. Achieving nutrient removal.
  - e. All of the above
4. The contact stabilization process assumes that organic matter is first \_\_\_\_\_ by the microorganisms and then organic matter is \_\_\_\_\_ by the microorganisms for energy and growth.
5. In a contact stabilization activated sludge process, the maximum organic loading should be no more than \_\_\_\_\_ per 1,000 cubic feet/day.
6. The Kraus Process is applicable to treatment facilities receiving waste water that is low in carbohydrates.
  - a. True
  - b. False
7. The \_\_\_\_\_ - \_\_\_\_\_ Aeration Process can be used to provide a more uniform distribution of oxygen demand throughout the aeration tank.
8. In general, the \_\_\_\_\_ process requires the longest minimum aeration time.
9. Oxidation ditches are configured in a ring with \_\_\_\_\_ flow around the ring that is induced by aerators.
10. Because of its relatively low mixed liquor suspended solids (MLSS) concentration and its head-end loading, the \_\_\_\_\_ activated sludge process is most suitable for low-strength, domestic wastes with minimal peak load considerations.

**Exercise – Unit 1:** Place the letter of the description before the appropriate treatment process.

- \_\_\_\_\_ Conventional
- \_\_\_\_\_ Complete-Mix
- \_\_\_\_\_ Contact Stabilization
- \_\_\_\_\_ Extended aeration/  
oxidation ditch
- \_\_\_\_\_ Step-feed
- \_\_\_\_\_ Kraus

A. The principal benefits of this modification include reduced sludge handling and lower power requirements. Of the processes listed, this type of plant will perform the best in regards to achieving nitrification because of the long aeration and MCRT.

B. The benefits of this modification include greater hydraulic loading, a more stable microbial population, more efficient aeration, and tolerance of shock loads. These systems may be used for nitrification, however; they can be more sensitive to pH drops.

C. This process is most suitable for low-strength, domestic wastes with minimal peak loads. The system works well for nitrification. However, the process is susceptible to failure from shock loads.

D. This process is often used to treat wastewater that is nitrogen deficient, high in carbohydrates and has poor settling characteristics.

E. This process presumes that organic matter (BOD) destruction is a two-step process in which BOD is first adsorbed by the microorganisms then metabolized by the microorganisms for energy and growth. Hydraulic detention times are too short for significant nitrification to occur making the process unsuitable for nitrification. This modification performs well under high flow, wet weather conditions.

F. This process modification is used to provide a more uniform distribution of oxygen demand throughout the aeration tank. It is particularly beneficial when dealing with variable shock loads. It can be used to provide partial nitrification, however; detention times are too low for complete nitrification to occur.

<sup>1</sup> California State University, Sacramento, Department of Civil Engineering, *Operation of Wastewater Treatment Plants Volume I*, 4<sup>th</sup> ed., (Sacramento, CA: The California State University, Sacramento Foundation, 1994).

<sup>2</sup> *Operation of Wastewater Treatment Plants Volume 1*, 4<sup>th</sup> ed.

<sup>3</sup> *Operation of Wastewater Treatment Plants Volume II*, 5<sup>th</sup> ed., page 86, figure 11.23.

<sup>4</sup> *Operation of Wastewater Treatment Plants Volume II*, 5<sup>th</sup> ed., p. 89, figure 11.25.

<sup>5</sup> *Operation of Wastewater Treatment Plants Volume II*, 5<sup>th</sup> ed., p. 91, figure 11.26.

<sup>6</sup> *Operation of Wastewater Treatment Plants Volume II*, 5<sup>th</sup> ed., p. 92, fig. 11.28.

<sup>7</sup> <http://www.elibrary.dep.state.pa.us/dsweb/Get/Document-48793/362-0300-001.pdf>, p.78.

---

---

# Unit 2 – The Sequencing Batch Reactor

---

---

## Learning Objectives

- Explain the basic operating principles of Sequencing Batch Reactors.
- State the differences between a Sequencing Batch Reactor and Continuous Activated Sludge Process.
- Explain the configuration of a Sequencing Batch Reactor System, including preliminary treatment, reactor components, sequencing control, and ancillary treatment.
- Describe the stages of operation for a Sequencing Batch Reactor.
- Discuss the reasons for wasting sludge from a Sequencing Batch Reactor.
- Identify key guidelines for operating a Sequencing Batch Reactor.
- Describe important process control considerations for a Sequencing Batch Reactor.

---

## DESCRIPTION OF THE SEQUENCING BATCH REACTOR (SBR) PROCESS

---

### Basic Operating Principles of the Sequencing Batch Reactor (SBR)

Following are the basic overview principles of the SBR:

- The SBR is a fill-and-draw activated sludge system.
- Wastewater enters a partially filled reactor containing biomass.
- When the required operating liquid level is reached, influent flow to the reactor stops and a specified, timed treatment sequence begins.
- Because the influent flow to each reactor is not continuous, at least two reactors are necessary to accommodate a system with continuous influent flow.

### Parameters of the SBR

- Multiple processing stages occur in one tank.
  - SBRs use specified time durations for each treatment process.
  - A typical operating schedule includes fill, react, settle, decant, and idle stages.
  - Stage timing is usually controlled automatically.
- Multiple processing cycles occur each day.
  - Typically, from two to six complete treatment cycles will be completed in each reactor each day.
- Batch processing of wastewater occurs.
  - A normal SBR system operates in the batch mode, wherein the influent flow is cyclic and each batch is processed through the entire treatment process.
- SBR modifications provide continuous processing of wastewater.
  - A modification of the normal SBR process allows for continuous influent flow without sacrificing the benefits of the SBR process.
    - The Intermittent Cycle Extended Aeration System (ICEAS) operates with a continuous influent flow and a periodic discharge.
    - ICEAS uses an inlet baffle to separate the inlet zone from the reactor zone, allowing semi-batch treatment with minimal disruption of clarification.

---

## DESCRIPTION OF THE SEQUENCING BATCH REACTOR (SBR) PROCESS

---

### Key Differences Between SBRs and Continuous Activated Sludge

The unit processes of SBRs and conventional activated sludge systems are the same. However, these processes occur over time in the SBR; in the conventional system, the unit processes occur simultaneously.

#### Inflow/Outflow Characteristics

- Both influent and effluent flows occur periodically in an SBR, which is a batch activated sludge process; therefore, the continuous treatment plant influent periodically transitions from one reactor to another.



How do influent and effluent flows occur in the conventional activated sludge process?

---

---

#### Aeration Schedule

- Aeration is just one of several treatment stages in the SBR.



When does aeration occur in the conventional activated sludge process?

---

---

#### Organic Loading Schedule

- Organic loading occurs intermittently, within the influent flow, in the SBR.



When does organic loading occur in the conventional activated sludge process?

---

---

#### Mixed Liquor Management

- Mixed liquor always remains in the reactor in SBR systems; no sludge return is required.



What happens to the return sludge in the conventional activated sludge process?

---

---



## DESCRIPTION OF THE SEQUENCING BATCH REACTOR (SBR) PROCESS

---

### Clarification Efficiency

- Clarification occurs in an ideal environment in the SBR because there is no flow through the reactor during the clarification stage.



What makes clarification efficiency less than ideal in the conventional activated sludge process?

---

---

### Complexity of Operation

- There is not a significant difference in the overall complexity of operation between SBRs and conventional activated sludge processes.
- Each SBR reactor is required to perform several functions, making operation of the reactor more complex than any one component of a conventional activated sludge system.
- Because the conventional activated sludge system uses several individual components, operation of the conventional system may be considered to be more complex than operation of any one SBR reactor.
- SBR systems require a minimum of two reactors to handle continuous flow; however, each reactor has less mechanical equipment than a conventional activated sludge system (including the clarifier and return activated sludge components).

# CONFIGURATION OF A SEQUENCING BATCH REACTOR (SBR) SYSTEM

## Preliminary Treatment

- Most treatment plants have some preliminary treatment to protect treatment equipment and preserve the effectiveness of the treatment process.
- As is typical of most extended aeration systems, primary clarification is not commonly used for SBRs

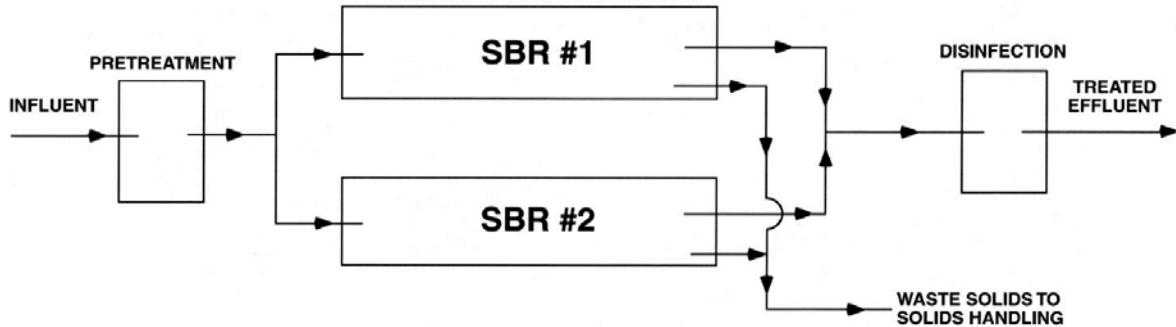

Figure 2.1 SBR Treatment Train with Preliminary Treatment<sup>1</sup>

## Reactor Components

### Tanks



- Multiple tanks are required; the minimum is two.
  - One reactor fills and reacts while the other settles and decants.
- For best practice, use a minimum of three reactors to ensure that continuous operation is possible at all times.
- Tank configurations vary with manufacturers, but the most common configuration is rectangular.
- SBR reactors are usually deeper than conventional activated sludge aeration tanks.
- The maximum operating depth for typical SBR reactors ranges from 12 to 20 feet.

## CONFIGURATION OF A SEQUENCING BATCH REACTOR (SBR) SYSTEM

### Decanters

- Decanter designs and configurations vary with the manufacturer.
- Decanters can be fixed-elevation or variable-elevation (floating) devices.
- Floating decanters are more expensive, but offer more flexibility in operation.

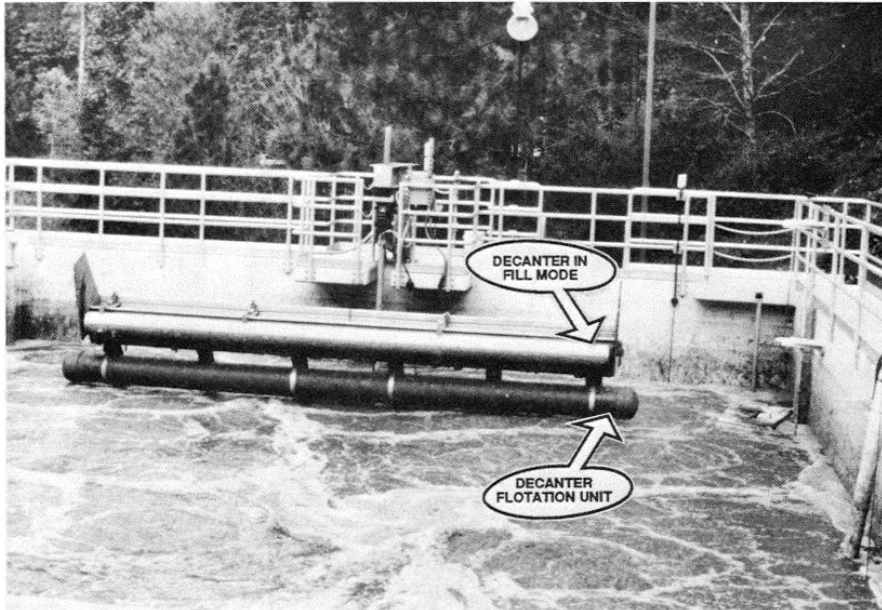

Decanter out of water during react (aeration) cycle

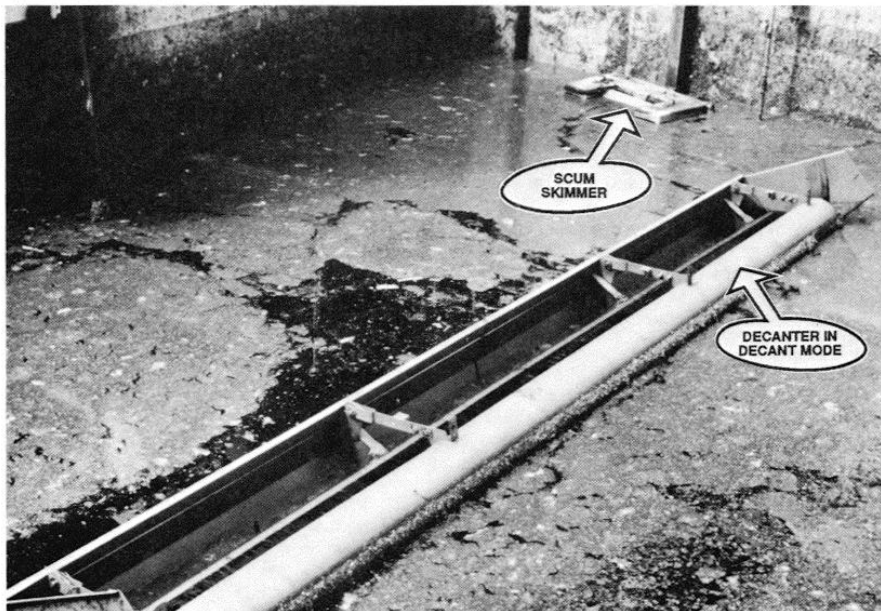

Decanter in water during settle cycle

Figure 2.3 Decanters

---

## CONFIGURATION OF A SEQUENCING BATCH REACTOR (SBR) SYSTEM

---

### Aeration and Mixing Equipment

- The same aeration and mixing equipment that is used for conventional activated sludge systems is used in the SBR systems.
- Mechanical mixers are commonly used in SBRs.
  - A submerged turbine aerator that uses mechanical mixing and optional aeration is often used for SBR systems.
- The use of air diffusers without mechanical mixers limits the flexibility of the SBR system.
  - Air diffusers alone are not used in SBR systems designed for nutrient removal because anoxic or anaerobic treatment cycles are required for nutrient removal.
- Jet aerators are used more often in SBR systems than in conventional activated sludge systems because of their ability to mix without aerating.
  - Jet aerators can be used with only a liquid motive force (for pumping mixed liquor), or with a combination of liquid and air streams to aerate.

### Activated Sludge Wasting Components

- Sludge wasting is performed on an as-needed basis to manage the food to microorganism ratio in the SBR.
- Sludge wasting occurs intermittently, following the decant stage or during the idle stage of operation.
- Sludge is removed by gravity line or by pumps.

## Sequencing Control

### The PLC

- A Programmable Logic Controller (PLC) controls the sequencing of the reactor cycles.
- A battery backup should be installed to provide power to the PLC in case of power failure.
- Good practice requires that the PLC also be protected by an Uninterruptible Power Supply (UPS) to prevent PLC memory loss and to maintain normal operations during short power outages.

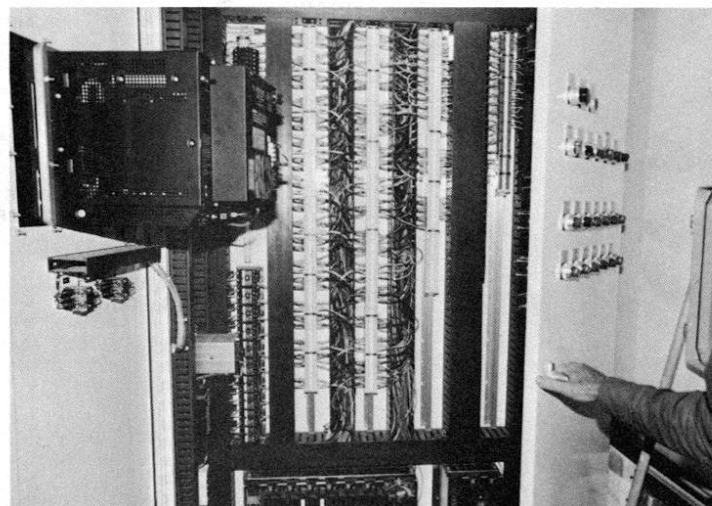
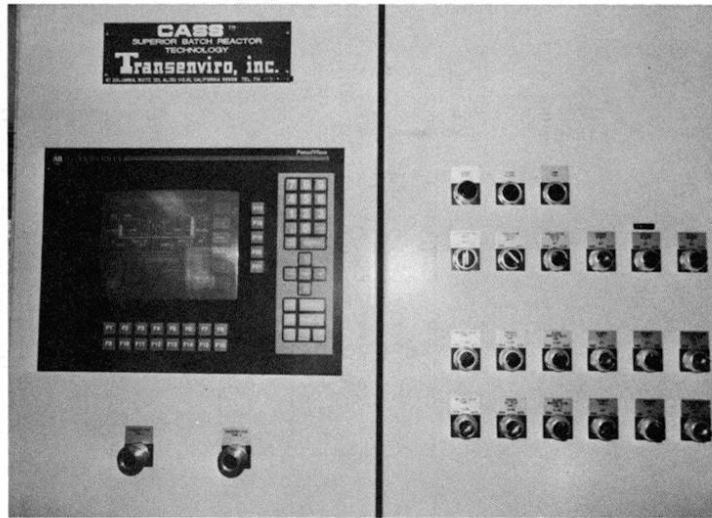

Figure 2.4 Programmable Logic Controller<sup>4</sup>

## **CONFIGURATION OF A SEQUENCING BATCH REACTOR (SBR) SYSTEM**

---

### **Automatically Actuated Valves**

- Operations regulated or controlled by pneumatic, solenoid, or motorized valves can all be controlled from a centralized location with a PLC.

### **Instrumentation**

- Motor starters, valves, level controls, timers, flow meters, and pressure switches are all controlled by the PLC.
- Display panels may be used to provide an operational overview and the status of individual instrumentation devices.

### **Software**

- The PLC software is usually supplied by the PLC manufacturer.
- The software is unique for each individual SBR system manufacturer; it is one of the main features that differentiate between SBR systems.

## Ancillary Treatment

Post treatment can be used to disinfect the effluent or to process waste activated sludge.

### Disinfection of Effluent

- Effective disinfection requires adequate contact time between the effluent and the disinfection chemical.
- Disinfection of SBR effluent requires special consideration because the effluent flow rate from an SBR is typically much greater than the average influent flow rate to the treatment facility, since the effluent is discharged as a batch, not continuously.
- If equalization of SBR effluent is not provided, the disinfection facilities must be sized to handle the SBR effluent flow rate, while still providing the requisite time for effective disinfection.

### Processing of Waste Activated Sludge

- Waste activated sludge may be discharged directly to sludge drying beds.
- Alternately, some SBR facilities are supported by aerobic sludge digesters that process waste activated sludge from the SBRs.

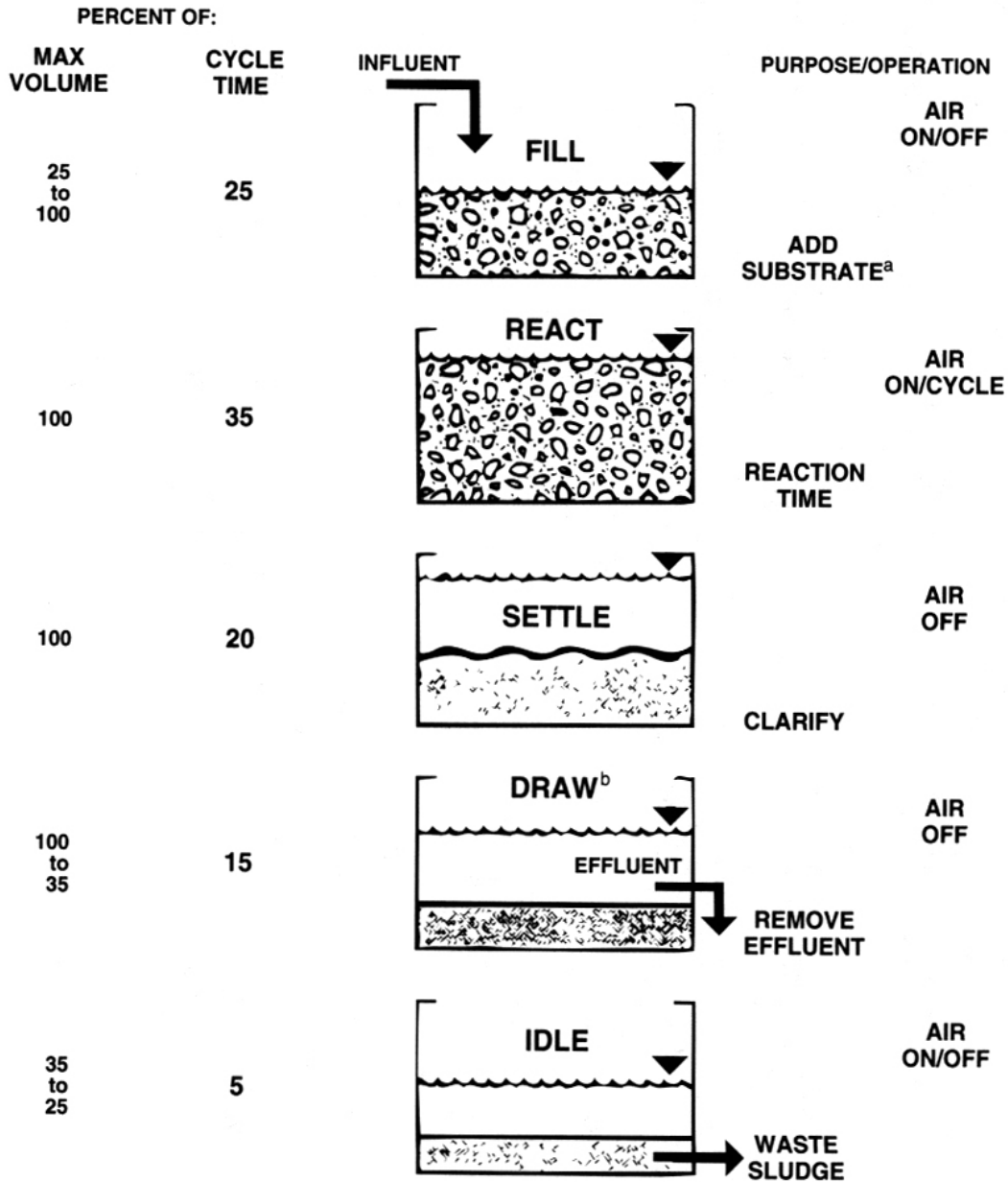

Figure 2.5 Processing of Waste Activated Sludge<sup>5</sup>



# OPERATION OF SEQUENCING BATCH REACTORS (SBRs)

## Stages of Operation



<sup>a</sup> Substrate—The base or food on which an organism lives.

<sup>b</sup> Draw—The decant or treated wastewater removal phase.

(Source: Irvine, Robert L., *TECHNOLOGY ASSESSMENT OF SEQUENCING BATCH REACTORS*, US EPA, Cincinnati, OH)

### 2.6 Stages of the SBR<sup>6</sup>

---

## OPERATION OF SEQUENCING BATCH REACTORS (SBRs)

---

The following details what you may expect in each of the operational modes.

### Fill

- During the fill stage, effluent from the primary treatment systems discharges to one or more of the SBR reactors.
- During this stage, the fluid level in the reactor is increased from the low water level (achieved after decanting) to the high water level.
- The fill cycle can be operated in a variety of ways, depending upon the treatment objective(s).
  - o Fill can occur without any mixing or aeration; with mixing only; or with mixing and aeration.

### React

- After the SBR is filled to the high fluid level, the react cycle typically begins.
- When the SBR is operating in the extended aeration mode, the react cycle is operated with full aeration and mixing to achieve the desired treatment.
  - o Alternately, depending on the treatment objectives, the react stage may be operated with mixing but without aeration.

### Settle

- Generally, settling occurs under quiescent conditions with no mixing or aeration.
  - o Quiescent settling facilitates the formation of a sludge blanket, which produces a clear supernatant above the sludge blanket.
- In some situations, gentle mixing during the initial settling stage may encourage floc formation and produce a better quality effluent.
- Control of the settling stage duration is usually based on a timed cycle. .

### Decant

- During the decant stage, supernatant liquid is withdrawn from the top of the liquid surface in the reactor and is discharged as plant effluent.
  - o Because there is no influent flow during the decant stage, the liquid level in the tank decreases as supernatant is withdrawn from the reactor.
- Baffles or weirs are typically used to prevent scum and other floating solids from entering the effluent discharge.

## **OPERATION OF SEQUENCING BATCH REACTORS (SBRs)**

---

### **Idle**

- Idle stage is not a required SBR operating stage.
- An idle stage, if needed, is used to allow the multiple SBR reactors to synchronize so that one SBR reactor can complete its fill stage before the plant influent is allowed to discharge to the idling reactor.
- The idle stage can be used for removal of waste sludge.

### Operating Guidelines

Operating guidelines vary significantly, depending upon the treatment objective(s). Operating guidelines for industrial wastewaters will differ from guidelines for municipal wastewater. The following information is a generalized overview of operating guidelines.

#### F/M Ratio

- For municipal wastewater, with operation of the SBR as a typical aeration plant, the F/M ratio is 0.05 to 0.10.
- For municipal wastewater, if the objective is not to nitrify, an appropriate F/M ratio would be 0.15 to 0.4.

#### MLSS Concentration

- The MLSS concentration maintained in the SBR ranges from 2000 to 5000 milligrams per liter (mg/L), when there is a low liquid level in the SBR.
- Consistency is required in calculating the MLSS concentrations because the liquid level in the SBR reactor varies with time. Therefore the MLSS concentration must be sampled during the same phase every time.

#### Sludge Age

- SBRs are operated as extended aeration facilities and have a sludge age typical of those systems: from 25 to 45 days.

#### Reaction Stage Dissolved Oxygen (DO) Concentration

- During full aeration of the SBR reactor during the react stage, the DO concentration should not be limiting and should range from at least 1.0 mg/L to approximately 3.0 mg/L.
- Other modes of operation are possible; this could dictate DO concentrations during the react stage that would be different from that suggested above.

# OPERATION OF SEQUENCING BATCH REACTORS (SBRs)

## Process Control Considerations

### Modifying the Stages of a Cycle to Affect Performance

- It is relatively easy to modify the stages of an SBR cycle by adjusting the timing for each treatment stage with the PLC.
  - New treatment cycles can be added, and the characteristics of each treatment cycle can be altered.
  - These changes require an operator who is knowledgeable about the PLC.
- Radical changes in the SBR cycles require prior knowledge of the required process parameters and/or close process monitoring to ensure the success of process changes.

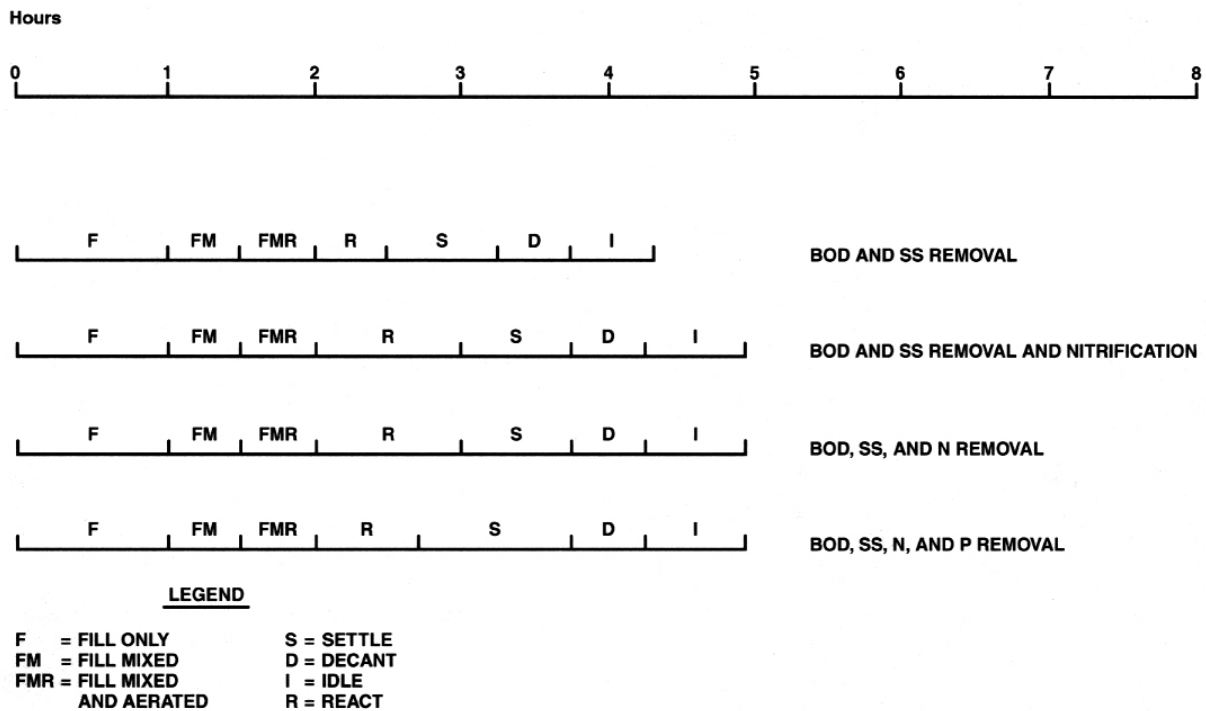

(Source: Arora, Madan L. and Umphres, Peggy B., *TECHNICAL EVALUATION OF SEQUENCING BATCH REACTORS*, US EPA, Cincinnati, OH).

Figure 2.7 Typical Operational Strategies<sup>7</sup>



Why is the settling time longer when removing phosphorus (P)?

---

---

### Monitoring Consistency

- Monitoring requirements for SBRs are very similar to those of other activated sludge systems.
- F/M ratio and dissolved oxygen concentrations are basic parameters that should be monitored for all activated sludge systems, including SBRs.
  - Since SBRs are somewhat unique, in that several processes occur in a single tank.
    - Monitoring activities must account for this uniqueness.
    - Effective monitoring will be done consistently at the same time in the cycle.
    - Measurement of the MLSS, in particular, is critical to process monitoring and must always be conducted at the same point in the process cycle.

### Knowing Your PLC

- The PLC is the heart of the SBR operation because it controls the operation of the mechanical equipment and the timing of the treatment stages.
- Operators need to be familiar with the operation of the PLC in order to properly operate and control the SBR process.
- Operator knowledge should extend to being able to troubleshoot the PLC and to knowing how to return the PLC back into service if a power failure occurs and the uninterruptible power supply (UPS) is not online.

**Key Points for Unit 2 – The Sequencing Batch Reactor (SBR)**

- Typically, at least two Sequencing Batch Reactors (SBRs) are needed to accommodate a system with continuous influent flow.
- A SBR system can typically finish from two to six complete processing cycles per day.
- A typical SBR cycle contains the following stages: fill, react, settle, decant and idle.
- SBR systems are usually deeper than conventional activated sludge aeration tanks.
- Sludge wasting occurs intermittently on an as needed basis in the SBR.
- A Programmable Logic Controller (PLC) controls the operation of the mechanical equipment and the timing of the treatment stages in a SBR process.



Exercise for Unit 2 – The Sequencing Batch Reactor

1. The maximum operating depth of a typical SBR system ranges from \_\_\_\_\_ to \_\_\_\_\_ feet.
2. SBR systems can in general use the same aeration and mixing equipment that is used for conventional activated sludge systems.
  - a. True
  - b. False
3. PLC means \_\_\_\_\_. A PLC controls the mechanical equipment and the timing of the different stages.
4. List the five stages of operation in a SBR and briefly explain what happens in each stage.

a.

---

---

---

b.

---

---

---

c.

---

---

---

d.

---

---

---

e.

---

---

---



<sup>1</sup> California State University, Sacramento, Department of Civil Engineering, *Operation of Wastewater Treatment Plants, Volume II, 5<sup>th</sup> ed.*, (Sacramento, CA: The California State University, Sacramento Foundation), page 95, figure 11.29.

<sup>3</sup> *Operation of Wastewater Treatment Plants* page 98, figure 11.31.

<sup>4</sup> *Operation of Wastewater Treatment Plants*, p. 101, figure 11.34.

<sup>5</sup> *Operation of Wastewater Treatment Plants*, p. 100, figure 11.33.

<sup>6</sup> *Operation of Wastewater Treatment Plants*, p. 102, figure 11.35.

<sup>7</sup> *Operation of Wastewater Treatment Plants*, p. 104, figure 11.36.

Bureau of Water Standards and Facility Regulation  
Division of Technical and Financial Assistance

May 2014

Sustainable Infrastructure  
Wastewater Operations Informational Sheet

**“Sequential Batch Reactors (SBR)”  
Activated Sludge**

**Important Notice:** The information contained in this document is for informational purposes only and IS NOT an all-inclusive source of information in regard to SBR systems. This sheet is intended to assist operators with a basic understanding of SBR systems. Please consult with your system manufacturer and engineer for specific details and information in regard to your SBR system. All facility owners and operators should become familiar with your facility NPDES Permit and the requirements for compliance contained within the permit. Nothing contained herein should be considered an endorsement or condemnation by PA DEP of any person, product, location or technique.



*For more information please contact:*  
Thomas J. Brown – Water Program Specialist  
Pennsylvania DEP – Cambria Office  
286 Industrial Park Road  
Ebensburg, PA 15931  
Tele: (814) 472-1900  
[thbrown@state.pa.us](mailto:thbrown@state.pa.us)

---

## Glossary of Terms and Acronyms

- **BNR** – **B**iological **N**utrient **R**emoval (typically nitrogen and phosphorus in wastewater).
- **BOD** – **B**iochemical **O**xigen **D**emand
- **DMR** – **D**ischarge **M**onitoring **R**eport, to be submitted to regulatory authorities typically on a monthly basis as required by the facility NPDES Permit.
- **ENR** - **E**nhanced **N**utrient **R**emoval provides a greater degree of treatment when compared to BNR.
- **F/M** – **F**ood to **M**icroorganism ratio.
- **MCRT** – **M**ean **C**ell **R**esidence **T**ime
- **MLSS** – **M**ixed **L**iquor **S**uspended **S**olids
- **MLVSS** – **M**ixed **L**iquor **V**olatile **S**uspended **S**olids
- **NH<sub>3</sub>-N** – Formula for ammonia nitrogen in wastewater
- **NO<sub>2</sub>** – Formula for Nitrite in wastewater
- **NO<sub>3</sub>** – Formula for Nitrate in wastewater
- **NPDES** – **N**ational **P**ollutant **D**ischarge **E**limination **S**ystem, all facilities that discharge must have an NPDES permit. This permit dictates the terms, conditions and parameters for operating your treatment plant. This permit is backed by state and federal law.
- **PA DEP** – Pennsylvania Department of Environmental Protection, the state regulatory agency.
- **POTW** – **P**ublicly **O**wned **T**reatment **W**orks
- **SBR** – **S**equential **B**atch **R**eactor, a type of activated sludge process that treats wastewater in batches.
- **Sludge Age** – The theoretical age of the solids under aeration in the system, basically the same calculation as MCRT.
- **SVI** – **S**ludge **V**olume **I**ndex is a calculation that indicates the tendency of activated sludge solids (aerated solids) to thicken or to become concentrated during the sedimentation/thickening process.
- **SWD** – **S**ide **W**ater **D**epth, the depth of water in a tank at any given time.
- **TN** – **T**otal **N**itrogen
- **US EPA** – **U**nited **S**tates **E**nvironmental **P**rotection **A**gency, the federal regulatory agency.
- **WAS** – **W**aste **A**ctivated **S**ludge refers to the amount of sludge (or biosolids) removed or wasted from the system.

## **Activated Sludge - Sequential Batch Reactor (SBR) Operational Information Sheet**

### **Introduction:**

The sequential batch reactor is a form of activated sludge and is subject to all of the operating parameters that would be applied to any other activated sludge system (such as F/M, SVI, MLSS, alkalinity, etc...). A solid understanding of the activated process is necessary in order to properly operate an SBR system. The batch reactor differs from a conventional flow through system in that everything happens within a given tank in different modes. There is no separate aeration tank and clarifier as you would find in a flow through system. There are at least two batch reactor tanks and in some cases many more. The batch reactor relies on a computer or programmable logic controller (PLC) to sequence and control the batches.

As with any activated sludge system, maintaining a proper mass balance is crucial for proper treatment. Simply put, the mass balance refers to the amount of living biomass (activated sludge) we must maintain in order to obtain proper treatment. Too much or too little biomass will result in inadequate or poor treatment. The typical measurement for the determination of required biomass (activated sludge) is known as the "Food to Microorganisms Ratio (F/M). For all wastewater treatment systems, effluent parameters will dictate the degree of treatment necessary and the amount of biomass (activated sludge) that must be maintained. Facilities with permit requirements for nitrification, denitrification and phosphorus removal will require much closer operator scrutiny and action in order to maintain proper treatment. Facilities that are required to achieve nitrification will typically run a much higher "Mean Cell residence Time (MCRT) or "Sludge Age" as compared to a facility that has no such requirement.

SBR's (as well as any other biological treatment process) will produce excess sludge or biosolids that must be removed and disposed of. Proper handling of sludge is essential through a regular routine of wasting in order to maintain a proper mass balance. A detailed estimation of sludge production can be found in the US EPA handbook titled "Improving POTW Performance Using the Composite Correction Approach". As a general rule of thumb, you can figure that you will produce ½ lb of new sludge per pound of BOD removed. Facilities that add a metal salt (such as aluminum sulfate) for phosphorus removal can expect higher sludge production rates.

### **General Information:**

Sequencing and programming may change a bit from manufacturer to manufacturer. In many cases SBR's go through the following five modes during normal operations, however storm flow could significantly change these modes and the time spent in each.

- Fill
- React
- Settling
- Decanting
- Idle (may not happen, especially during high flows)

The following figure details what you may expect in each of the operational modes

Figure – 1 (SBR Operational Modes)

<p><b>Fill</b> biological treatment</p>	<p>Influent raw wastewater entering the reactor during this mode, there may also be periods of mixing without aeration (anoxic) and mixing with aeration (aerobic). cBOD removal, nitrification and denitrification may be taking place during this mode. Typically, you would want raw wastewater (carbon source) for anoxic denitrification periods. No wastewater is being discharged in this mode. The amount of time spent in this mode could be dependent on flow; storm flow could significantly limit the amount of time.</p>
<p><b>React</b> biological treatment</p>	<p>During this mode, there is typically no raw wastewater entering the SBR (this could be different in storm mode). Periods of aerobic and anoxic treatment may occur to provide for cBOD removal, nitrification and denitrification. No wastewater is being discharged in this mode. This is a time for reaction, providing time for the microorganisms contained in the SBR to consume and convert the pollutants in the wastewater</p>
<p><b>Settling</b> physical treatment</p>	<p>During this mode there is typically no wastewater entering or exiting the SBR. There is no mixing or aeration; it is a quiescent period that provides for settling of the mixed liquor. In this mode the SBR is essentially a clarifier.</p>
<p><b>Decanting</b> physical treatment</p>	<p>In the decanting mode, the treated wastewater is decanted from the reactor and sent on for disinfection. It is typically in this mode that sludge is also wasted from the system</p>
<p><b>Idle</b> endogenous phase</p>	<p>As the name suggests, this is a mode where the process is at an idle. There is no wastewater entering or exiting the system. There may be some mixing and aeration. The biomass is at endogenous respiration. Some reactors may not have an idle mode or the idle mode may not be used during wet weather.</p>

Each of the modes (and SBR tanks) is controlled by some type of computer or Programmable Logic Controller (PLC). A PLC failure could make it very difficult or impossible to run the reactor.

Since SBR's process wastewater batches, the disinfection portion of the treatment plant may be larger when compared to other facilities of similar size. There may be periods of the day when no wastewater is being discharged. In some cases, flow equalization (or storage) is used to buffer the impact of batch discharges; this may be especially true on small sensitive receiving waters.

Depending on the manufacturer, you may have some flexibility in adjusting batches for optimization. In any event, high flow or storm mode may present the biggest challenge in regard to maintaining proper biological treatment and keeping the biomass within the treatment system. A detailed Wet Weather Operational Strategy should be in place to deal with high flow conditions. Be sure to review this critical mode and plan of operation with your engineer and the manufacturer.

### **Biological Treatment during a Batch**

In the previous section we discussed the physical operational phases for a batch reactor. In this section we will take a closer look at the biological aspects. Keep in mind that the biological phases may happen multiple times during a complete batch. For the most part, most biological treatment takes place during the *Fill* and *React* cycles. The *Settling* and *Decanting* phases of a batch are a quiescent period of physical treatment that generally does not include much in the way of biological treatment. The *Idle* period is a time of endogenous respiration to simply keep the organisms healthy and active although endogenous decay may occur.

During the *Fill* and *React* cycles of the batch, we have biological treatment of wastes with periods of mixing and aeration (aerobic) and mixing without aeration (anoxic or anaerobic). This is especially true for systems designed for biological nutrient reduction (BNR). BNR systems are concerned with reducing the amount of total nitrogen and phosphorus discharged. If you do not have total nitrogen limits in your permit, it still makes sense to take advantage of the process of denitrification from a sustainable infrastructure cost savings perspective through the beneficial uptake of nitrate (produced during nitrification) and the release of alkalinity.

For the purposes of clarification there is also a term known as ENR which simply stands for enhanced nutrient reduction. ENR facilities typically have multiple stages or phases for greater reduction of nutrients. Generally, facilities with a limit of <6.0 mg/l N and <0.5 mg/l P fall into this category.

We will now take a closer look at the following terms

- Anaerobic (mixing without aeration)
  - Anoxic (mixing without aeration)
  - Aerobic (mixing with aeration)
1. **Anaerobic** – For the purposes of BNR or ENR, this term **SHOULD NOT** be confused with fermentive anaerobic conditions as would be found in anaerobic digestion.

Anaerobic conditions found in a BNR system are primarily designed to assist with the removal of phosphorus in the wastewater. In an anaerobic zone or during an anaerobic cycle, there will be mixing without aeration, we like to see the dissolved oxygen as close to zero as possible. Nitrates (NO<sub>3</sub>) will also be depleted. The presence of nitrates or dissolved oxygen would inhibit the anaerobic process intended to release phosphorus. In this condition (no dissolved oxygen and no nitrates), the organisms contained in the biomass release or give up the phosphorus they were holding. There can also be a significant uptake of cBOD during this process. In most cases, facilities that utilize biological means (BNR or ENR) for phosphorus removal also have a chemical means for the removal of phosphorus as well.

- \* Mixing without aeration.
- \* Release of phosphorus.
- \* Uptake of cBOD.
- \* No dissolved oxygen or nitrates.

2. **Anoxic** – Similar to anaerobic as we have mixing without aeration. The primary purpose in this cycle is for denitrification (conversion of nitrate to nitrogen gas). In order for denitrification to take place, we must have nitrates present. In this case, facultative organisms search for another electron acceptor (such as nitrate) for respiration. As with the anaerobic zone, we want to deplete elemental oxygen (DO). We want DO levels to be as close to zero as possible (< 0.3 mg/l). In a flow through system, there would be a nitrate recycle from the aerobic zone. In the case of a batch reactor, the anoxic period would come after a period of nitrification (aerobic) so nitrates would be present. You will also experience the release of alkalinity during proper denitrification. The facultative organisms also need a carbon source such as raw wastewater we therefore may see this cycle taking place during the fill cycle for a batch reactor. Carbon can also come from endogenous decay or through an added source such as methanol. As nitrates are depleted, we may automatically slip into an anaerobic mode (given enough time).

- \* Mixing without aeration.
- \* Consumption of nitrates (NO<sub>3</sub>), release of nitrogen gas (denitrification)
- \* Uptake of cBOD.
- \* Release of alkalinity (about 3.6 lbs/ per lb of nitrate converted to nitrogen)
- \* Carbon source needed for denitrification.

**Note: While DO probes are effective at monitoring oxygen levels during the aeration phase, ORP probes should be used to monitor conditions during the anaerobic and anoxic phases due to the nearly negligible levels of oxygen present.**

3. **Aerobic** – During this period we have mixing and aeration. We typically like to see dissolved oxygen levels of greater than 2.0 mg/l to sustain nitrification. In this process we can consume any remaining cBOD, achieve nitrification (conversion of ammonia nitrogen to nitrate nitrogen) and we will also have a beneficial uptake of phosphorus through phosphorus accumulating organisms (PAO's). As you may recall from the anaerobic cycle, phosphorus is released by the organisms during times of oxygen deprivation. When exposed to aeration, the organisms take back all the phosphorus they gave up plus a bit more. This phenomenon is known as luxury uptake of phosphorus. In this cycle we also can achieve nitrification. The process of nitrification is purely aerobic and requires a large volume of dissolved oxygen and alkalinity. It takes approximately

4.6 lbs of dissolved oxygen and 7.2 lbs of alkalinity to convert one pound of ammonia into nitrate. The use of ORP probes can be helpful in determining when biological cycles are complete.

- \* Mixing with aeration
- \* Nitrification (converting toxic ammonia into nitrate)
- \* Luxury uptake of phosphorus through PAO's
- \* DO typically greater than 2.0mg/l but not greater than 4.0 mg/l
- \* Consumption of alkalinity (for nitrification)
- \* Consumption of large volumes of oxygen (for nitrification)

The process of nitrification, denitrification and phosphorus removal requires close operator input and scrutiny. The scope of this document provides only a brief overview of these topics. It is essential for all operators of activated sludge systems to become familiar with the principles of nitrification, denitrification and phosphorus removal. It should be noted that partial nitrification or partial denitrification could lead to the production of nitrite (NO<sub>2</sub>) that could in turn produce problems with wastewater disinfection. Due to the large volume of alkalinity consumed during nitrification, pH values could also drop suddenly. As a rule of thumb, you would like to see about 100 mg/l of alkalinity left over after complete nitrification. Alkalinity concentration of less than 50 mg/l could lead to significant problems and the loss of nitrification.

While the reduction of nutrients is desirable in many wastewater effluent streams, you need to keep in mind that there is a fundamental requirement for nutrients in order for biological wastewater systems to function properly. The rule is you need one pound of phosphorus and 5 pounds of nitrogen for every 100 lbs of incoming BOD.

1(P):5(N):100(BOD) Rule. In most cases, municipal wastewater systems have adequate nutrients. Some industrial sources with high BOD loading (with low nutrients) can cause a problem.

### **SBR Operations and Maintenance**

ALL wastewater systems need to develop and implement an **operations and maintenance plan** that provides for **sustainable infrastructure** and includes the following major categories.

- a. Process control
- b. Wet weather operations plans and strategy
- c. Solids handling and management
- d. Preventative and emergency maintenance
- e. Energy Efficiency
- f. Security and emergency planning
- g. Facility safety (included with all aspects)

To further detail, a good **operations and maintenance plan** is well documented, easy to follow and should contain the following elements at a minimum;

1. A description of average, seasonal or diurnal characteristics of the influent wastewater and trucked in wastes.



2. A flow schematic of all processes (including recycle, supernatant or filtrate flows).
3. Identification of each individual treatment unit and an assessment of its criticality. Consider reducing criticality of key processes that could jeopardize the entire treatment process. For SBR systems the computer or PLC that controls the system is mission critical. You should be able to replace or re-program in short order.
4. The normal operating ranges and expected removal efficiencies of each treatment unit.
5. Identification of sampling points, methods and calculations to be used to make process control adjustments and a schedule for carrying out these process control operations.
6. A plan for monitoring all treatment units. This includes identifying parameters to be monitored and action plans when trigger levels for parameters are reached.
7. Any standard operating procedures and guidelines to maintain permit compliance.
8. Identification of key processes and equipment and an outline of how key processes will be monitored and adjusted during times the operators may be absent or unable to personally monitor the key process. (*\*Note – A key process is any process that should it fail will or may cause harm to human or environmental health*)
9. A preventative and emergency maintenance plan for all process equipment including an inventory of essential spare parts and methods for emergency repairs in accordance with manufacturer's recommendations. Said plans should contain emergency contact information for selected contractors, equipment manufacturers and vendors. The plan should contain scheduling of routine maintenance and tracking of all equipment maintenance. The use of elapsed time meters can assist with scheduling of maintenance and also in the identification of unusual conditions. Detailed procedures should be identified for maintenance personnel to follow to ensure compliance with manufacturer recommendations. Safety procedures should also be detailed.
10. Security and emergency response plans that cover both man-made and natural disasters that may impact the facility.
11. Identification and mitigation of actual and potential hazards. Establish procedures to ensure safety of plant personnel and visitors for all aspects of operation and maintenance. This includes the use of appropriate PPE.
12. A wet weather operational strategy that maximizes the flow through the treatment plant while minimizing the washout of biological solids from the system. This may include programming changes for wet weather events, work closely with you engineer and manufacturer to optimize batch settings. This could include the placement of current density baffles or the use of polymers.
13. A solids management plan that details how sludge and other treatment residues will be wasted, treated, handled and disposed of during times of normal operation as well as during times of adversity.

14. A daily checklist should be developed that the facility operators use to monitor all treatment processes. Any unusual conditions should be noted and addressed as soon as possible
  15. A communications scheme that allows the operators to convey essential information to the system owners in regard to compliance status.
  16. Monitoring of utility usage (such as electrical energy, natural gas, water). Implement strategies for energy savings where applicable.
- ALL key processes should be monitored and connected to an alarm dialer that activates and notifies operator of the problem.

### **SBR Specific Process Control Issues**

Due to the fact an SBR processes wastewater in batches, there are some considerations with regard to process control. All treatment systems (including batch reactors are impacted by diurnal changes in flow and strength of wastewater. Operators must be familiar with these impacts. As previously mentioned, wet weather operations will present some of the biggest challenges.

The specific issue here is that the water level (mixed liquor) is variable based upon the mode, time of day and other factors. In a conventional flow through plant the water level always remains basically the same. In a batch reactor if you measure the MLSS at 8ft depth and then again at 12ft, the concentration of the MLSS will change. The MLSS reading needs to correlate to the depth of the tank and must be taken during a time of mixing and/or aeration. When calculating an F/M Ratio you would need to know the depth of the reactor and the MLSS in order to calculate the pounds of solids under aeration. The following example takes a hypothetical treatment plant and calculates the F/M Ratio.

#### *Example 1 - F/M Calculation for SBR*

*Details – 2 Unit SBR @50 ft long 15 ft wide and a maximum SWD of 14ft*

*Minimum discharge depth 8ft SWD*

*50 X 15 X 14 = 10,500 cubic feet (max) X 7.48 = 78,540 gal max*

*Total plant daily flow = 0.25 MGD, Influent BOD = 200 mg/l*

*.25 X 200 X 8.34 = 417 lbs of BOD, ½ the flow going to each unit **208 lbs (F)** each*

**Unit 1** had a MLSS concentration of 3500 mg/l with a SWD of 12 ft

*50 X 15 X 12 = 9000ft cu ft. X 7.48 = 67,320 gallons or .06732 million gallons*

*.06732 X 3500 X 8.34 = **1965 lbs of solids under aeration (M)***

**(F)208/(M)1965 = 0.1 F/M**

**Unit 2** had a MLSS concentration of 3000 mg/l with a SWD of 14 ft

*50 X 15 X 14 = 10,500 cu ft. X 7.48 = 78,540 gal or .07854 million gallons*

*.07854 X 3000 X 8.34 = **1965 lbs of solids under aeration(M)***

**(F)208/(M)1965 = 0.1 F/M**

The use of a centrifuge can help you estimate the MLSS concentration.

The desired F/M ratio for many SBR systems ranges between 0.04 – 0.10. Please refer to your facility Operations and Maintenance Guide for specific F/M information for your system. Your engineer as well as the manufacturer will be able to provide you guidance in achieving the desired F/M. As the operator, you may determine the optimum F/M for your facility based on operational process control records and reports.

Some conventional activated sludge plants use a constant MLSS concentration as a means of process control. Since your side water depth (SWD) changes, you will have to maintain certain number of lbs under aeration as opposed to a constant MLSS.

The same issue (in regard to side water depth) applies when doing a 30 minute settleability test. You should take this sample at the same SWD each day while aeration and mixing are occurring. If you are calculating an SVI the same applies.

### **SBR Effluent Sampling Issues**

Since an SBR discharges in batches, collecting a 24hour/effluent composite sample is a little more difficult. There will be times during the day that there is no discharge. Your sampling device should be tied to a flow meter that collects a sample after every “X” amount of gallons. For example, we could program the sampler to take a 100 ml sample for every 1000 gallons discharged. If you do not have a composite sampler that is tied to a flow meter, you need to get one. In the interim you could manually collect a composite sample by grabbing a sample during the start of the discharge cycle, the middle of the discharge cycle and one at the end of the discharge cycle (at a minimum) for each batch discharged for that day. Please refer to your facility NPDES permit for specific sampling requirements. Remember that your samples must be representative of the nature and volume of wastewater you are discharging. ALL samples for DMR reporting must be performed by an accredited laboratory.

### **On-Line instrumentation for SBR's**

The use of on-line continuous monitors can greatly enhance the operator's ability to properly operate and maintain an SBR process, especially for facilities that are achieving nitrification and denitrification (BNR). On-line continuous monitoring instruments can provide feedback to a control panel (for operator interpretation) or they can be hooked up to the facility computer or PLC to change the aeration and mixing cycles to optimize nitrification and denitrification. The use of these instruments will add to the sustainability of the infrastructure by;

- Improving effluent water quality
- Help control filamentous organisms – better sludge settling
- Reduced sludge production
- Increasing Energy Efficiency (reducing un-needed aeration, enhanced uptake of NO<sub>3</sub>).
- Reduce or eliminate the need to add supplemental alkalinity

Even if your facility does not have requirements for total nitrogen, the use of denitrification in the treatment cycle can result in significant savings.

Recommended on-line measurement instrumentation includes:

- Oxidation Reduction Potential (ORP)
- Dissolved Oxygen (DO)
- Nitrate (NO<sub>3</sub>)
- Ammonia-Nitrogen (NH<sub>3</sub>-N)
- pH

The above are recommended as a minimum for proper process control, additional probes or instruments can be added based upon the needs of your specific site. Speak to your engineer and manufacturer for details about your facility needs. As with any instrumentation proper care and calibration is essential.

Please review with your engineer and the manufacturer for the optimal array of instrumentation for your operating conditions.

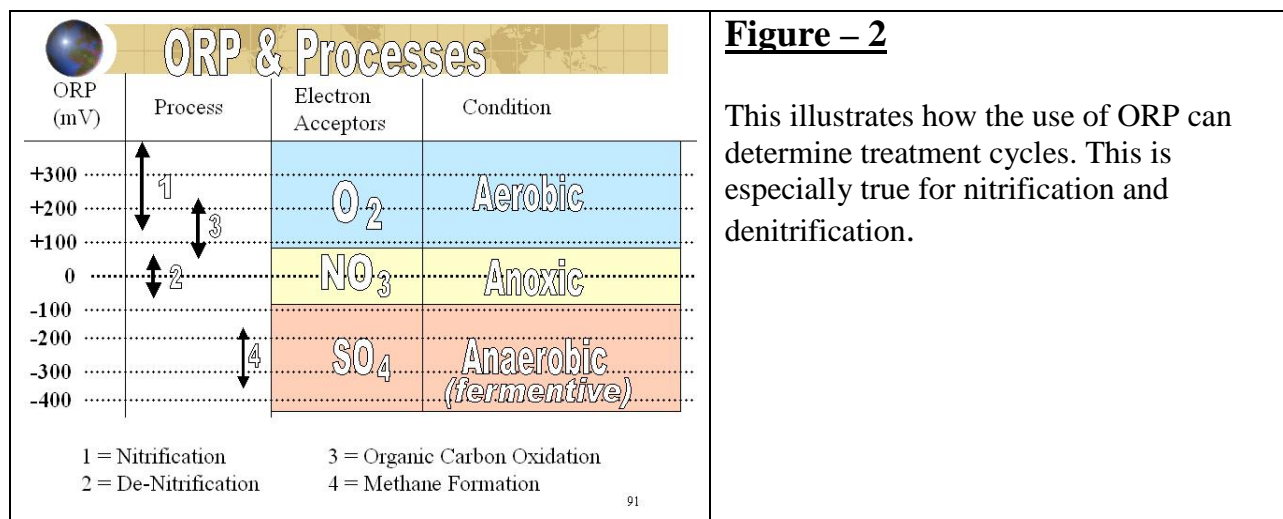

**Figure – 2**

This illustrates how the use of ORP can determine treatment cycles. This is especially true for nitrification and denitrification.

### Recommended Process Control Tests, Observations and Calculations

The following is suggested for proper process control. The actual testing you do and how frequently you do it will be based upon your circumstances. If you are not sure, consult your engineer and state regulatory officials. It is important that you do testing on the influent wastewater so you can determine loadings and efficiencies of all treatment units. Influent testing also provides valuable information for chapter 94 reports as well. At a minimum you should test your influent wastewater each time you collect samples for effluent testing (NPDES Reporting). The operator should also note weather conditions on a daily basis Hi/Lo temperature and amount (if any) precipitation.

The following describes the parameters you should be monitoring (at a minimum) in regard to influent wastewater. Depending on your facility, additional parameters may need to be monitored especially if your facility treats industrial or trucked in waste.

<b>Influent Wastewater Recommended Parameters</b>	
cBOD	24 Hour Composite
Total Suspended Solids (TSS)	24 Hour Composite
Ammonia-Nitrogen (NH <sub>3</sub> -N)	24 Hour Composite
PO <sub>4</sub>	24 Hour Composite
pH	Grab
Temperature	Grab
Alkalinity	Grab
Flow (MGD)	Continuous monitoring
Visual/Aromatic Observations	Document unusual conditions

For monitoring the SBR's, the following are the monitoring parameters, calculations and observations you should institute. The frequency of these will depend on the variability of your waste-stream and other factors. Refer to "SBR Specific Process Control Issues" when sampling, testing or performing calculations on an SBR

<b>Dissolved Oxygen</b>	Best done with continuous monitoring within the reactor. Calibration of DO sensors should be checked weekly.
<b>Oxidation Reduction Potential (ORP)</b>	Best done with continuous monitoring within the reactor.
<b>Nitrate (NO<sub>3</sub>)</b>	Best done with continuous monitoring within the reactor. Occasional grabs (to check calibration) during each cycle.
<b>Nitrite (NO<sub>2</sub>)</b>	Can be a grab sample at various intervals. If you are having problems maintaining chlorine residual excess nitrite can be a factor. Nitrite can be associated with incomplete nitrification or incomplete denitrification
<b>Ammonia-Nitrogen (NH<sub>3</sub>-N)</b>	Best done with continuous monitoring within the reactor. Occasional grabs (to check calibration) during each cycle.
<b>MLSS &amp; MLVSS</b>	This test is essential for determining the lbs of solids you have under aeration. The use of a centrifuge spin can provide quick and reasonable estimates of solids under aeration. With an increase in MCRT, the MLVSS should decrease.

<p><b>Mean Cell Residence Time</b></p>	<p>MCRT is a calculation.  <math display="block">\frac{\text{lbs of solids in the system}}{\text{Solids leaving the system (WAS \&amp; Effluent)}}</math></p>
<p><b>Food to Microorganism Ratio</b></p>	<p>F/M is a calculation (be aware of SWD).  <math display="block">\frac{\text{FOOD (BOD) coming into system}}{\text{lbs of solids under aeration}}</math></p>
<p><b>Sludge Volume Index (SVI)</b></p>	<p>SVI is a calculation  <math display="block">\frac{30 \text{ Minute Settleability Result ml/l}}{\text{MLSS mg/l} / 1000}</math></p>
<p><b>Microscopic Examination</b></p>	<p>Microscopic observation of the biomass to determine the relative predominance of organisms and to spot troublesome filamentous organisms.</p>
<p><b>30 Minute Settleability</b></p>	<p>To help quantify the amount of sludge in the system and to determine settling characteristics. Must be used in conjunction with MLSS to determine SVI. Remember to account for your side water depth. Best taken towards the end of the React cycle.</p>
<p><b>Alkalinity</b></p>	<p>This can be a grab sample, should not drop below 50 mg/l at any point in the system especially for facilities that must nitrify. Would like to see 100 mg/l in effluent after complete nitrification.</p>
<p><b>pH</b></p>	<p>This can be done through continuous monitoring or through a grab sample. Alkalinity is more important. Drastic changes in pH will occur when alkalinity is consumed.</p>
<p><b>Temperature</b></p>	<p>The temperature will determine how lively your biological activity will be every 10 degree C change in temperature results in biological activity either doubling (warmer temps) or cutting in half (for colder temps).</p>

<b>Dissolved Oxygen Uptake Rate(DOUR)</b>	Useful test for determining the respiration rate of the biomass. Can be used to determine treatability of waste.
<b>Amount and concentration of sludge wasted from each SBR</b>	We must be able to quantify the amount of sludge removed from the system in order to maintain a proper mass balance.
<b>Recycle flows</b>	This could include flows such as supernatant from aerobic digesters or filtrate from dewatering or thickening activity. These recycle flows can be high in nutrients (phosphorus and nitrogen) as well as BOD

### **SBR Daily Checks and Activities**

All treatment plants should be checked on a daily basis. The following is a (minimum) list of items that should be checked on a daily basis.

1. Upon arrival, check condition of gates fences and doors be sure facility is secure when you arrive and again when you leave. If there are any signs of tampering or break-ins, notify law enforcement immediately.
2. Check operation of blowers and mixing equipment. Assure all equipment is working properly.
3. Check operation of computers or PLC
4. Check operation of decanting mechanisms and float switches (if any).
5. Perform any routine maintenance that may be required (as determined by manufacturer's recommendations).
6. Perform daily lab work and calculations (as well as any process control testing, calculation or observation that may be due), adjust or fill chemical feeders as needed.
7. Check condition of disinfection system for proper operation
8. Check operation of pumps.
9. Pay attention to any unusual odors, noises or characteristic of wastewater, note and investigate unusual items.
10. Immediately notify the system owner of any real or potential problem that is or may cause permit violations
11. Thoroughly document activities. Graph results of sampling and calculations for easy interpretation.

If you are using chlorine for disinfection, you should use a sludge judge (or similar device) to determine the accumulation of sludge in the contact tanks on a weekly basis. Excess solids in the chlorine contact tanks must be removed.

**Other Useful Information**

Operator of SBR's must be thoroughly familiar with the activated sludge process. This includes the process of nitrification, denitrification and phosphorus removal. DEP has training modules and videos that can provide useful information in regard to proper operation of activated sludge systems.

- DEP DVD – Intro to activated sludge, nitrification, denitrification and chemical feed systems.
- DEP wastewater training modules 8,12,15,16,17,18
- There are also a number of other texts available in regard to activated sludge, nitrification, denitrification, phosphorus removal and BNR from the Water Environment Federation (WEF) and many other private vendors,